

Publication 639
June 2010
Part No. 22674.39
Revision: 03.01.23

McCONNEL

85HP Contractor Series Hedgecutters PA5585 – PA9085TT Range

Operator Manual



IMPORTANT

VERIFICATION OF WARRANTY REGISTRATION



Dealer Warranty Information & Registration Verification

It is imperative that the selling dealer registers this machine with McConnel Limited before delivery to the end user – failure to do so may affect the validity of the machine warranty.

To register machines; log onto <https://my.mcconnel.com> and select 'Machine Registration' which can be found in the 'Warranty' section of the site. **Confirm to the customer that the machine has been registered by completing the verification form below.**

Registration Verification	Serial No. <input type="text"/>
Dealer Name:	
Dealer Address:	
Customer Name:	
Date of Warranty Registration:/...../..... Dealer Signature:	

Note to Customer / Owner

Please ensure the section above has been completed and signed by the dealer to verify your machine has been registered with McConnel Limited.

IMPORTANT: During the initial 'bedding in' period of a new machine it is the customer's responsibility to regularly inspect all nuts, bolts and hose connections for tightness and re-tighten if required. New hydraulic connections occasionally weep small amounts of oil as the seals and joints settle in – where this occurs it can be cured by re-tightening the connection – *refer to torque settings chart below*. The tasks stated above should be performed on an hourly basis during the first day of work and at least daily thereafter as part of the machine's general maintenance procedure.

CAUTION: DO NOT OVER TORQUE HYDRAULIC FITTINGS AND HOSES

Torque Settings for Hydraulic Fittings

Hydraulic Hose Ends		
BSP	Setting	Metric
1/4"	18 Nm	19 mm
3/8"	31 Nm	22 mm
1/2"	49 Nm	27 mm
5/8"	60 Nm	30 mm
3/4"	80 Nm	32 mm
1"	125 Nm	41 mm
1.1/4"	190 Nm	50 mm
1.1/2"	250 Nm	55 mm
2"	420 Nm	70 mm

Port Adaptors with Bonded Seals		
BSP	Setting	Metric
1/4"	34 Nm	19 mm
3/8"	47 Nm	22 mm
1/2"	102 Nm	27 mm
5/8"	122 Nm	30 mm
3/4"	149 Nm	32 mm
1"	203 Nm	41 mm
1.1/4"	305 Nm	50 mm
1.1/2"	305 Nm	55 mm
2"	400 Nm	70 mm

WARRANTY POLICY

WARRANTY REGISTRATION

All machines must be registered, by the selling dealer with McConnel Ltd, before delivery to the end user. On receipt of the goods it is the buyer's responsibility to check that the Verification of Warranty Registration in the Operator's Manual has been completed by the selling dealer.

1. LIMITED WARRANTIES

1.01. *All mounted machines supplied by McConnel Ltd are warranted to be free from defects in material and workmanship from the date of sale to the original purchaser for a period of 12 months, unless a different period is specified.*

All Self Propelled Machines supplied by McConnel Ltd are warranted to be free from defects in material and workmanship from the date of sale to the original purchaser for a period of 12 months or 1500 hours. Engine warranty will be specific to the Manufacturer of that unit.

1.02. *All spare parts supplied by McConnel Ltd and purchased by the end user are warranted to be free from defects in material and workmanship from the date of sale to the original purchaser for a period of 6 months. All parts warranty claims must be supported by a copy of the failed part invoice to the end user. We cannot consider claims for which sales invoices are not available.*

1.03. *The warranty offered by McConnel Ltd is limited to the making good by repair or replacement for the purchaser any part or parts found, upon examination at its factory, to be defective under normal use and service due to defects in material or workmanship. Returned parts must be complete and unexamined. Pack the component(s) carefully so that any transit damage is avoided. All ports on hydraulic items should be drained of oil and securely plugged to prevent seepage and foreign body ingress. Certain other components, electrical items for example, may require particular care when packing to avoid damage in transit.*

1.04. *This warranty does not extend to any product from which McConnel Ltd's serial number plate has been removed or altered.*

1.05. *The warranty policy is valid for machines registered in line with the terms and conditions detailed and on the basis that the machines do not extend a period of 24 months or greater since their original purchase date, that is the original invoice date from McConnel Limited. Machines that are held in stock for more than 24 months cannot be registered for warranty.*

1.06. *This warranty does not apply to any part of the goods, which has been subjected to improper or abnormal use, negligence, alteration, modification, fitment of non-genuine parts, accident damage, or damage resulting from contact with overhead power lines, damage caused by foreign objects (e.g. stones, iron, material other than vegetation), failure due to lack of maintenance, use of incorrect oil or lubricants, contamination of the oil, or which has served its normal life. This warranty does not apply to any expendable items such as blades, belts, clutch linings, filter elements, flails, flap kits, skids, soil engaging parts, shields, guards, wear pads, pneumatic tyres or tracks.*

1.07. *Temporary repairs and consequential loss - i.e. oil, downtime and associated parts are specifically excluded from the warranty.*

1.08. *Warranty on hoses is limited to 12 months and does not include hoses which have suffered external damage. Only complete hoses may be returned under warranty, any which have been cut or repaired will be rejected.*

1.09. *Machines must be repaired immediately a problem arises. Continued use of the machine after a problem has occurred can result in further component failures, for which McConnel Ltd cannot be held liable, and may have safety implications.*

1.10. *If in exceptional circumstances a non McConnel Ltd part is used to effect a repair, warranty reimbursement will be at no more than McConnel Ltd's standard dealer cost for the genuine part.*

- 1.11. *Except as provided herein, no employee, agent, dealer or other person is authorised to give any warranties of any nature on behalf of McConnell Ltd.*
- 1.12. *For machine warranty periods in excess of 12 months the following additional exclusions shall apply:*
 - 1.12.1. *Hoses, exposed pipes and hydraulic tank breathers.*
 - 1.12.2. *Filters.*
 - 1.12.3. *Rubber mountings.*
 - 1.12.4. *External electric wiring.*
 - 1.12.5. *Bearings and seals*
 - 1.12.6. *External Cables, Linkages*
 - 1.12.7. *Loose/Corroded Connections, Light Units, LED's*
 - 1.12.8. *Comfort items such as Operator Seat, Ventilation, Audio Equipment*
- 1.13. *All service work, particularly filter changes, must be carried out in accordance with the manufacturer's service schedule. Failure to comply will invalidate the warranty. In the event of a claim, proof of the service work being carried out may be required.*
- 1.14. *Repeat or additional repairs resulting from incorrect diagnosis or poor quality previous repair work are excluded from warranty.*

NB Warranty cover will be invalid if any non-genuine parts have been fitted or used. Use of non-genuine parts may seriously affect the machine's performance and safety. McConnell Ltd cannot be held responsible for any failures or safety implications that arise due to the use of non-genuine parts.

2. REMEDIES AND PROCEDURES

- 2.01. *The warranty is not effective unless the Selling Dealer registers the machine, via the McConnell web site and confirms the registration to the purchaser by completing the confirmation form in the operator's manual.*
- 2.02. *Any fault must be reported to an authorised McConnell Ltd dealer as soon as it occurs. Continued use of a machine, after a fault has occurred, can result in further component failure for which McConnell Ltd cannot be held liable.*
- 2.03. *Repairs should be undertaken within two days of the failure. Claims submitted for repairs undertaken more than 2 weeks after a failure has occurred, or 2 days after the parts were supplied will be rejected, unless the delay has been authorised by McConnell Ltd. Please note that failure by the customer to release the machine for repair will not be accepted as a reason for delay in repair or submitting warranty claims.*
- 2.04. *All claims must be submitted, by an authorised McConnell Ltd Service Dealer, within 30 days of the date of repair.*
- 2.05. *Following examination of the claim and parts, McConnell Ltd will pay, at their discretion, for any valid claim the invoiced cost of any parts supplied by McConnell Ltd and appropriate labour and mileage allowances if applicable.*
- 2.06. *The submission of a claim is not a guarantee of payment.*
- 2.07. *Any decision reached by McConnell Ltd. is final.*

3. LIMITATION OF LIABILITY

- 3.01. *McConnell Ltd disclaims any express (except as set forth herein) and implied warranties with respect to the goods including, but not limited to, merchantability and fitness for a particular purpose.*
- 3.02. *McConnell Ltd makes no warranty as to the design, capability, capacity or suitability for use of the goods.*
- 3.03. *Except as provided herein, McConnell Ltd shall have no liability or responsibility to the purchaser or any other person or entity with respect to any liability, loss, or damage caused or alleged to be caused directly or indirectly by the goods including, but not limited to, any indirect, special, consequential, or incidental damages resulting from the use or operation of the goods or any breach of this warranty. Notwithstanding the above limitations and warranties, the manufacturer's liability hereunder for damages incurred by the purchaser or others shall not exceed the price of the goods.*
- 3.04. *No action arising out of any claimed breach of this warranty or transactions under this warranty may be brought more than one (1) year after the cause of the action has occurred.*

4. MISCELLANEOUS

- 4.01. McConnel Ltd may waive compliance with any of the terms of this limited warranty, but no waiver of any terms shall be deemed to be a waiver of any other term.*
- 4.02. If any provision of this limited warranty shall violate any applicable law and is held to be unenforceable, then the invalidity of such provision shall not invalidate any other provisions herein.*
- 4.03. Applicable law may provide rights and benefits to the purchaser in addition to those provided herein.*

McConnel Limited

POWER ARM & TRACTOR PRE-OPERATION INSPECTION

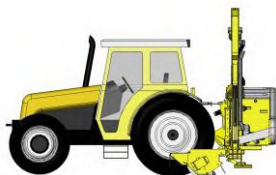

A daily equipment inspection of machine and tractor should be conducted before the equipment is used.

Use the inspection sheets on the following pages to assist with these daily inspections. Damaged or missing guards should be repaired or replaced before operating the mower. Failure to repair or replace damaged guards can result in objects being thrown from the mower and possibly hitting the operator and/or bystanders.

Inspect the Mower for Safe Operating Condition

- Make sure the driveline guards and shielding are in place and in good repair.
- Inspect the flexible thrown object shielding to assure that they are in place on the front and rear of the mower head and in good repair. Repair or replace any damaged or missing thrown object shields.
- Ensure the mower cutting height is set high enough to reduce the possibility of the mower blades contacting the ground. Actual height will be dependent on the ground conditions. Increase the height when working in rough or undulating conditions.
- Inspect for broken, chipped, bent, missing, or severely worn blades. Replace damaged blades before operating the mower. Ensure the blade retaining bolts and fasteners are secure and tight.
- Ensure all head bolts and nuts are tight.
- Lubricate the driveline universal joints and telescoping members daily.
- Grease the rotor and roller bearings and inspect their condition.
- Inspect for any oil leaks or damaged hoses.
- Inspect for worn and/or damaged decals and safety instructions. Replace unreadable, damaged or missing safety decals.
- Follow the operator's manual(s) inspection and maintenance instructions for lubricating parts, and keeping thrown object shielding, driveline guards, rotating parts shields, mower blades, and decals in good repair.

Inspect the Tractor for Safe Operating Condition

- Inspect the controls, lights, SMV's (Slow Moving Vehicle sign), seat belts, and ROPS to ensure they are in place and in good working order.
- Ensure tyres, wheels, lug bolts/nuts are in good condition.
- Make sure the tractor brakes and steering are in proper operating condition.
- Follow the operator's manual(s) inspection and maintenance procedures for keeping the tractor in good and safe condition before operating.

Copies of the inspection sheets on the following pages should be retained in this manual for reference; two sets are included to allow removal of one set for photocopying purposes. Alternatively, these inspection sheets can be download from our website via the QR code or using the link below;
<https://my.mcconnel.com/service/pre-operation-inspection-documents/>





POWER ARM PRE-OPERATION INSPECTION



Power Arm ID Date: Shift:



WARNING: Before conducting the inspection, make sure the tractor engine is off, the key removed, all rotation has stopped and the tractor is in park with the parking brake engaged. Make sure the mower head is resting on the ground or is securely blocked up and supported and all hydraulic pressure has been relieved.

Item	Condition at start of shift	Specific Comments if not O.K.
The operator's manual is in the canister on the mower.		
All warning decals are in place, clean and legible.		
All lights are clean and working.		
The mounting frame bolts are in place and tight.		
The arm pivot pins are tight and correctly secured.		
There are no cracks in the arms.		
Hydraulic cylinder pins are tight and correctly secured.		
Hydraulic cylinder hose connections are tight.		
Hydraulic pump hose connections are tight.		
Hydraulic valve hose connections are tight.		
Hydraulic valve controls function properly.		
There are no damaged hoses.		
The oil level is to the green mark on the tank sight glass.		
There is no evidence of hydraulic oil leaks.		
Flails are not missing, chipped, broken or excessively worn.		
The flail bolts are tight.		
The front and rear flaps are fitted and in good condition.		
The front hood is in place and in good condition.		
The wire trap is in good condition.		
The skid shoes are in good condition and tight.		
There are no cracks or holes in flail casing.		
Hydraulic motor mounting bolts are tight.		
All flail head nuts and bolts are tight.		
The rotor bearings are in good condition and greased.		
The roller bearings are in good condition and greased.		
The drive line shaft guard is in good condition.		
The drive line shaft guard is correctly secured.		
Controls are securely mounted in the cab.		
With engine running check arm operation.		
Have a spare pack of flails, bushes, bolts and nuts.		

Operators Signature:

DO NOT OPERATE AN UNSAFE TRACTOR OR MACHINE



TRACTOR PRE-OPERATION INSPECTION

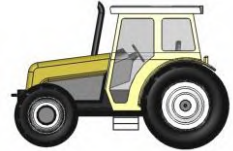

Power Arm ID Date: Shift:



WARNING: Before conducting the inspection, make sure the tractor engine is off, the key removed, all rotation has stopped and the tractor is in park with the parking brake engaged. Ensure any implement attached to the tractor is firmly on the ground.

Item	Condition at start of shift	Specific Comments if not O.K.
The flashing lights function properly.		
All lights are clean and working correctly.		
All cab windows are clean and wipers working correctly.		
The SMV sign, where required, is clean and visible.		
The tyres are in good condition with correct pressure.		
The wheel nuts are tight.		
The tractor brakes are in good condition.		
The steering linkage is in good condition.		
There are no visible oil leaks.		
The hydraulic controls function properly.		
The ROPS or ROPS cab is in good condition.		
The seatbelt is in place and in good condition.		
The 3-point hitch is in good condition.		
The drawbar/pick up hook is secure and in good condition.		
The PTO master shield is in place.		
The engine oil level is full.		
The brake fluid level is full.		
The power steering fluid level is full.		
The fuel level is adequate.		
The engine coolant fluid level is full.		
The radiator and oil cooler are free of debris.		
The air filter is in good condition.		

Operators Signature:

DO NOT OPERATE AN UNSAFE TRACTOR OR MACHINE



POWER ARM PRE-OPERATION INSPECTION

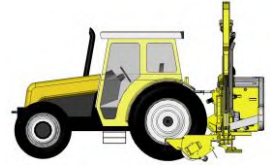

Power Arm ID Date: Shift:



WARNING: Before conducting the inspection, make sure the tractor engine is off, the key removed, all rotation has stopped and the tractor is in park with the parking brake engaged. Make sure the mower head is resting on the ground or is securely blocked up and supported and all hydraulic pressure has been relieved.

Item	Condition at start of shift	Specific Comments if not O.K.
The operator's manual is in the canister on the mower.		
All warning decals are in place, clean and legible.		
All lights are clean and working.		
The mounting frame bolts are in place and tight.		
The arm pivot pins are tight and correctly secured.		
There are no cracks in the arms.		
Hydraulic cylinder pins are tight and correctly secured.		
Hydraulic cylinder hose connections are tight.		
Hydraulic pump hose connections are tight.		
Hydraulic valve hose connections are tight.		
Hydraulic valve controls function properly.		
There are no damaged hoses.		
The oil level is to the green mark on the tank sight glass.		
There is no evidence of hydraulic oil leaks.		
Flails are not missing, chipped, broken or excessively worn.		
The flail bolts are tight.		
The front and rear flaps are fitted and in good condition.		
The front hood is in place and in good condition.		
The wire trap is in good condition.		
The skid shoes are in good condition and tight.		
There are no cracks or holes in flail casing.		
Hydraulic motor mounting bolts are tight.		
All flail head nuts and bolts are tight.		
The rotor bearings are in good condition and greased.		
The roller bearings are in good condition and greased.		
The drive line shaft guard is in good condition.		
The drive line shaft guard is correctly secured.		
Controls are securely mounted in the cab.		
With engine running check arm operation.		
Have a spare pack of flails, bushes, bolts and nuts.		

Operators Signature:

DO NOT OPERATE AN UNSAFE TRACTOR OR MACHINE



TRACTOR PRE-OPERATION INSPECTION

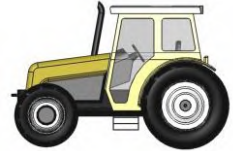

Power Arm ID Date: Shift:



WARNING: Before conducting the inspection, make sure the tractor engine is off, the key removed, all rotation has stopped and the tractor is in park with the parking brake engaged. Ensure any implement attached to the tractor is firmly on the ground.

Item	Condition at start of shift	Specific Comments if not O.K.
The flashing lights function properly.		
All lights are clean and working correctly.		
All cab windows are clean and wipers working correctly.		
The SMV sign, where required, is clean and visible.		
The tyres are in good condition with correct pressure.		
The wheel nuts are tight.		
The tractor brakes are in good condition.		
The steering linkage is in good condition.		
There are no visible oil leaks.		
The hydraulic controls function properly.		
The ROPS or ROPS cab is in good condition.		
The seatbelt is in place and in good condition.		
The 3-point hitch is in good condition.		
The drawbar/pick up hook is secure and in good condition.		
The PTO master shield is in place.		
The engine oil level is full.		
The brake fluid level is full.		
The power steering fluid level is full.		
The fuel level is adequate.		
The engine coolant fluid level is full.		
The radiator and oil cooler are free of debris.		
The air filter is in good condition.		

Operators Signature:

DO NOT OPERATE AN UNSAFE TRACTOR OR MACHINE



For Safety and Performance...

ALWAYS READ THE BOOK FIRST

McCONEL LIMITED

**Temeside Works
Ludlow
Shropshire
England**

**Telephone: +44 (0)1584 873131
www.mcconel.com**

- NOISE STATEMENT -

The equivalent daily personal noise exposure from this machine measured at the operators' ear is within the range 78 – 85 dB, these figures apply to a normal distribution of use where the noise fluctuates between zero and maximum. The figures assume that the machine is fitted to a tractor with a 'quiet' cab with the windows closed in a generally open environment. We recommend that the windows are kept closed. With the cab rear window open the equivalent daily personal noise exposure will increase to a figure within the range 82 – 88 dB. At an equivalent daily noise exposure level of 85 – 90 dB ear protection is recommended and must always be used if any window is left open.



Operating, servicing and maintaining this equipment can expose you to chemicals including gasoline, diesel fuel, lubricants, petroleum products, engine exhaust, carbon monoxide, and phthalates, which are known to the State of California to cause cancer and birth defects or other reproductive harm. To minimize exposure, avoid breathing exhaust, do not idle the engine except as necessary, service your vehicle in a well-ventilated area and wear gloves or wash your hands frequently when servicing your vehicle. Battery posts, terminals and related accessories contain lead and lead compounds, chemicals known to the state of California to cause cancer, birth defects or other reproductive harm. For more information go to www.P65Warnings.ca.gov. This website, operated by California's Office of Environmental Health Hazard Assessment, provides information about these chemicals and how individuals may be exposed to them.



For best performance ...

USE ONLY GENUINE McCONEl SERVICE PARTS

To be assured of the latest design improvements purchase your 'Genuine Replacements' from the 'Original Equipment Manufacturer'

McCONEl LIMITED

Through your local Dealer or Stockist

Always quote:

- ***Machine Type***
- ***Serial Number***
- ***Part Number***

Design improvements may alter some of the parts listed in this manual – the latest part will always be supplied when it is interchangeable with an earlier one.

LIST OF CONTENTS

General Information	1
Features and Specifications	2
Safety Information	3
Safety & Information Decals	9
Tractor Requirements	11
Vehicle/Tractor Preparation	12
Axle Bracket & Catch Assembly Fitment	13
Delivery & Pre-Attachment	14
Machine Attachment – <i>Axle Mounted Models</i>	17
Stabilizer	20
Machine Attachment – <i>Linkage Mounted Models</i>	22
PTO Driveshaft Installation	26
Control Unit Installation	27
Hydraulic Oil	28
Detachment – <i>Axle Mounted Models</i>	29
Detachment – <i>Linkage Mounted Models</i>	30
Flailhead Attachment	31
Operator Control Systems	32
Operation	33
Operator Guard	33
Slew & Lift Locks	34
Moving into the Transport Position	35
Transport Position	36
Moving from Transport to Work Position	37
Cab Protection Systems	38
Breakaway, Auto Reset & Slew	40
Powered Slew	41
Parallel Arm Geometry	41
VFR Operating Caution	42
Easy Drive System (EDS)	43
Angle Float & Lift Float	44
Telescopic Arm	45
Pre-Work Preparation & Precautions	46
Running Up Procedure	47
Emergency Stopping	47
Tele VFR Purge Procedure	48
Operating Speeds	52
Hazards & Dangers	53
Overhead Power Lines	54
Hedge Cutting Procedure	56
Flail Types	57
General Maintenance	59
Hydraulic System	62
Hydraulic Hoses	64
Top Link Damper	65
Electrical Connections	66
Auxiliary Box Wiring Diagram	67
PTO Shaft Maintenance	68
Tele Arm Wear Pads	69
Torque Chart	72
Troubleshooting Chart	73

GENERAL INFORMATION

Read this manual before fitting or operating the machine or accessory. Whenever any doubt exists contact your local dealer or the McConnel Service Department for assistance.

Only use 'Genuine McConnel Parts' on McConnel machinery and equipment.

DEFINITIONS: *The following definitions apply throughout this manual;*

⚠ DANGER

DANGER: Alerts to a hazardous situation which will result in death or serious injury if not observed carefully.

⚠ WARNING

WARNING: Alerts to a hazardous situation which could result in death or serious injury if not observed carefully.

⚠ CAUTION

CAUTION: Alerts to a hazardous situation which could result in damage to the machine and/or equipment if not observed carefully.

NOTICE

NOTICE: Specific or general information considered important or useful to emphasise.

LEFT HAND (LH) & RIGHT HAND (RH): *These terms are applicable to the machine when fitted to the tractor and viewed from the rear; these terms also apply to tractor references.*

SERIAL PLATE

All machines are equipped with a serial number plate containing important information relating to the machine including a unique serial number used for identification purposes.

Note: Images in this manual are provided for instruction and informational purposes only and may not show components in their entirety. In certain instances images may appear different to the actual machine; where this occurs the general procedure will be basically the same. E&OE.

MACHINE & DEALER INFORMATION

Record the serial number of your machine on this page and always quote it when ordering parts. Whenever information concerning the machine is requested remember to also state the make and model of tractor to which the machine is fitted.	
Machine Serial Number:	Installation Date:
Machine Model Details:	
Dealer Name & Branch:	
Dealer Address:	
Dealer Telephone No:	
Dealer Email Address:	

FEATURES & SPECIFICATIONS

All models

- Linkage or Axle Mounted
- Right or Left Hand Cutting
- Choice of Controls
- Choice of Flailheads
- Cast Iron Gearbox
- Hydraulic Breakaway
- Head Angle Float Kit
- 100° Powered Slew
- 225 Litre Hydraulic Tank
- 85HP Hydraulic System
- Operator Guard
- Cab Protector Kit
- Rear Lighting

Control Options

- Motion Controls
- Evolution Controls
- Revolution Proportional Controls

Arm Options

- Standard Arm
- Midcut Arm (1.0m Forward Extension)
- Midcut Arm (1.5m Forward Extension)
- VFR Arm (Variable Forward Reach)
- Tele Arm
- Twin Tele Arm
- Midcut / Tele Arm

Additional Options

- Lift Float Kit
- Easy Drive System (*Option Revolution Controls*)
- Debris Blower

Machine Weights (*Approximate*)

PA6085 models – 1340kg
PA6585 models – 1500kg
PA6585T models – 1650kg
PA7085T models – 1700kg
PA8085T models – 1800kg
PA6585T-VFR models – 1950kg
PA7285T-VFR models – 2004kg
PA8085T-VFR models – 2072kg
PA8085TT models – 2072kg
PA9085TT models – 2293kg



This machine has the potential to be extremely dangerous - in the wrong hands it can kill or maim; It is therefore imperative that both owner and operator of the machine reads and understands the following section to ensure they are fully aware of the dangers that do, or may exist, and their responsibilities surrounding the use and operation of the machine.

The operator of this machine is responsible not only for their own safety but equally for the safety of others who may come into the close proximity of the machine, as the owner you are responsible for both.

When the machine is not in use the cutting head should be lowered to rest on the ground. In the event of any fault being detected with the machine's operation it must be stopped immediately and not used again until the fault has been corrected by a qualified technician.

POTENTIAL SIGNIFICANT DANGERS ASSOCIATED WITH THE USE OF THIS MACHINE:

- ▲ *Being hit by debris thrown by rotating components.*
- ▲ *Being hit by machine parts ejected through damage during use.*
- ▲ *Being caught on a rotating power take-off (PTO) shaft.*
- ▲ *Being caught in other moving parts i.e.: belts, pulleys and cutting heads.*
- ▲ *Electrocution from Overhead Power Lines (by contact with or 'flashover' from).*
- ▲ *Being hit by cutting heads or machine arms as they move.*
- ▲ *Becoming trapped between tractor and machine when hitching or unhitching.*
- ▲ *Tractor overbalancing when machine arm is extended.*
- ▲ *Injection of high-pressure oil from hydraulic hoses or couplings.*
- ▲ *Machine overbalancing when freestanding (out of use).*
- ▲ *Road traffic accidents due to collision or debris on the road.*
- ▲ *Burn risk from hot components.*

BEFORE USING THIS MACHINE YOU MUST:

- ▲ *Ensure you read all sections of the operator handbook.*
- ▲ *Ensure the operator is, or has been, properly trained to use the machine.*
- ▲ *Ensure the operator has been issued with and reads the operator handbook.*
- ▲ *Ensure the operator understands and follows the instructions in operator handbook.*
- ▲ *Ensure the tractor front, rear and sides are fitted with metal mesh or polycarbonate guards of suitable size and strength to protect the operator against thrown debris or parts.*
- ▲ *Ensure tractor guards are fitted correctly, are undamaged and kept properly maintained.*
- ▲ *Ensure that all machine guards are in position, are undamaged, and are kept maintained in accordance with the manufacturer's recommendations.*
- ▲ *Ensure flails and their fixings are of a type recommended by the manufacturer, are securely attached and that none are missing or damaged.*
- ▲ *Ensure hydraulic pipes are carefully and correctly routed to avoid damage by chaffing, stretching or pinching and that they are held in place with the correct fittings.*
- ▲ *Always follow the manufacturer's instructions for attachment and removal of the machine from the tractor.*
- ▲ *Check that the machine fittings and couplings are in good condition.*
- ▲ *Ensure the tractor meets the minimum weight recommendations of the machine's manufacturer and that ballast is used as necessary.*
- ▲ *Always inspect the work area thoroughly before starting to note obstacles and remove wire, bottles, cans and other debris.*
- ▲ *Use clear suitably sized warning signs to alert others to the nature of the machine working within that area. Signs should be placed at both ends of the work site. (It is recommended that signs used are of a size and type specified by the Department of Transport and positioned in accordance with their, and the Local Highways Authority, guidelines).*
- ▲ *Ensure the operator is protected from noise. Ear defenders should be worn and tractor cab doors and windows must be kept closed. Machine controls should be routed through proprietary openings in the cab to enable all windows to be shut fully.*
- ▲ *Always work at a safe speed taking account of the conditions i.e.: terrain, highway proximity and obstacles around and above the machine. Extra special attention should be applied to Overhead Power Lines. Some of our machines are capable of reach in excess of 8 metres (26 feet) this means they have the potential to well exceed, by possibly 3 metres (9' 9"), the lowest legal minimum height of 5.2 metres from the ground for 11,000 and 33,000 volt power lines. It cannot be stressed enough the dangers that surround this capability, it is therefore vital that the operator is fully aware of the maximum height and reach of the machine, and that they are fully conversant with all aspects regarding the safe minimum distances that apply when working with machines in close proximity to Power Lines. (Further information on this subject can be obtained from the Health & Safety Executive or your Local Power Company).*

- ▲ *Always disengage the machine, kill the tractor engine, remove and pocket the key before dismounting for any reason.*
- ▲ *Always clear up all debris left at the work area, it may cause hazard to others.*
- ▲ *Always ensure when you remove your machine from the tractor that it is left in a safe and stable position using the stands and props provided and secured if necessary.*

WHEN NOT TO USE THIS MACHINE:

- ▲ *Never attempt to use this machine if you have not been trained to do so.*
- ▲ *Never use a machine until you have read and understood the operator handbook, are familiar with it, and practiced the controls.*
- ▲ *Never use a machine that is poorly maintained.*
- ▲ *Never use a machine if guards are missing or damaged.*
- ▲ *Never use a machine on which the hydraulic system shows signs of wear or damage.*
- ▲ *Never fit, or use, a machine on a tractor that does not meet the manufacturer's minimum specification level.*
- ▲ *Never use a machine fitted to a tractor that does not have suitable front, rear and side(s) cab guarding made of metal mesh or polycarbonate.*
- ▲ *Never use the machine if the tractor cab guarding is damaged, deteriorating or badly fitted.*
- ▲ *Never turn a machine cutting head to an angle that causes debris to be ejected towards the cab.*
- ▲ *Never start or continue to work a machine if people are nearby or approaching - Stop and wait until they are at a safe distance before continuing. WARNING: Some cutting heads may continue to 'freewheel' for up to 40 seconds after being stopped.*
- ▲ *Never attempt to use a machine on materials in excess of its capability.*
- ▲ *Never use a machine to perform a task it has not been designed to do.*
- ▲ *Never operate the tractor or machine controls from any position other than from the driving seat, especially whilst hitching or unhitching the machine.*
- ▲ *Never carry out maintenance of a machine or a tractor whilst the engine is running – the engine should be switched off, the key removed and pocketed.*
- ▲ *Never leave a machine unattended in a raised position – it should be lowered to the ground in a safe position on a level firm site.*
- ▲ *Never leave a tractor with the key in or the engine running.*
- ▲ *Never carry out maintenance on any part or component of a machine that is raised unless that part or component has been properly substantially braced or supported.*
- ▲ *Never attempt to detect a hydraulic leak with your hand – use a piece of cardboard.*
- ▲ *Never allow children near to, or play on, a tractor or machine under any circumstances.*

ADDITIONAL SAFETY ADVICE

Training

Operators need to be competent and fully capable of operating this machine in a safe and efficient way prior to attempting to use it in any public place. We advise therefore that the prospective operator make use of relevant training courses available such as those run by the Agricultural Training Board, Agricultural Colleges, Dealers and McConnel.

Working in Public Places

When working in public places such as roadsides, consideration should be paid to others in the vicinity. Stop the machine immediately when pedestrians, cyclists and horse riders etc. pass. Restart only when they are at a distance that causes no risk to their safety.

Warning Signs

It is advisable that any working area be covered by suitable warning signs and statutory in public places. Signs should be highly visible and well placed in order to give clear advanced warning of the hazard. Contact the Department of Transport or your Local Highways Authority to obtain detailed information on this subject. The latter should be contacted prior to working on the public highway advising them of the time and location of the intended work asking what is required by way of signs and procedure. – *‘Non-authorized placement of road signs may create offences under the Highways Act’.*

Suggested Warning Signs Required

‘Road works ahead’ warning sign with a supplementary ‘Hedge cutting’ plate. ‘For 1 mile’ or appropriate shorter distance may be added to the plate.

‘Road narrows’ warning signs with supplementary ‘Single file traffic’ plate.

White on blue ‘Keep right’ () arrow sign on rear of machine.*

** Note – this applies to UK Market machines where traffic passes to the right of a machine working in the same direction as the traffic flow. The direction, use and colour of the arrow sign will depend on the country of use and the Local Highway Authorities regulations in the locality.*

Use of Warning Signs

- ▲ *On two-way roads one set of signs is needed facing traffic in each direction.*
- ▲ *Work should be within 1 mile of the signs.*
- ▲ *Work only when visibility is good and at times of low risk e.g.: NOT during ‘rush-hour’.*
- ▲ *Vehicles should have an amber-flashing beacon.*
- ▲ *Ideally, vehicles should be conspicuously coloured.*
- ▲ *Debris should be removed from the road and path as soon as practicable, and at regular intervals, wearing high visibility clothing and before removing the hazard warning signs.*
- ▲ *Collect all road signs promptly when the job is completed.*

Although the information stated here covers a wide range of safety subjects it is impossible to predict every eventuality that can occur under differing circumstances whilst operating this machine. No advice given here can replace ‘good common sense’ and ‘total awareness’ at all times, but will go a long way towards the safe use of your McConnel machine.

Safe use of rotary flail hedge cutters

HSE information sheet

Agriculture Information Sheet No 21 (Revision 1)

Introduction

This information sheet outlines typical hazards when using most types of tractor-mounted rotary flail hedge cutter. It gives guidance on reducing risks to the operator and others during work with hedge cutters and will help employers, employees and the self-employed comply with their duties under health and safety law.

All users of rotary flail hedge cutters need to be aware of the particular features of their make/model of hedge cutter when considering the hazards, risks and precautions.

Hazards

The greatest risk of injury comes from contact with the machine's moving parts and in particular:

- entanglement on inadequately guarded power take-off shafts;
- contact with the cutter head parts, drive belts or pulleys;
- being struck by the cutting head or machine arm as it moves.

Other risks associated with tractor-mounted hedge cutters can include:

- being hit by material or other debris ejected by the cutters;
- being hit by component parts ejected from the machine;
- coming into contact with overhead electricity power lines (OHPLs);
- the tractor overbalancing when the machine arm is extended;
- injection of high-pressure oil from damaged hydraulic hoses or couplings;
- being struck by the machine overbalancing when un-hitched from the tractor;
- road traffic accidents due to collisions with other vehicles either directly or from debris on the road.

Control measures

It is extremely dangerous to carry out any work on a machine while it is under power. The most important safety measure is to follow the 'safe stop' procedure before dismounting, or carrying out any maintenance or adjustments, including dealing with a blockage or other problem:

- Handbrake on.
- Controls neutral.
- Stop engine.
- Remove key.

Guards and machine safety

Check that all guards and other protective devices are in place before starting work. Don't use the machine if the guards are missing or damaged. Make sure:

- the power take-off (PTO) shaft is fully enclosed in a guard along its entire length from the tractor power take-off to the power input connection on the hedge cutter;
- the tractor rear and side(s) are fitted with protective glazing, metal mesh or polycarbonate guards of a size/strength specified by the hedge cutter manufacturer to protect the operator against thrown debris or other projectiles;
- tractor mesh/polycarbonate guards are suitable for the job, undamaged and maintained in accordance with the manufacturer's instructions;
- all hedge cutter guards and safety devices are in position, correctly fitted and maintained in accordance with the manufacturer's recommendations;
- flails and their fixing heads are the right size for the task. Flails, and their fixings, should be of the type recommended by the manufacturer, securely attached, and should not be missing or damaged;
- hydraulic pipes are carefully routed to avoid damage;
- machine fittings and couplings are in good condition.

General guidance on safe working practice

- Operators should receive adequate instructions and training to enable them to use the machine safely. Take advantage of relevant training/courses provided by manufacturers/dealers. They will help ensure your safety and that of your staff, and help you get the best performance from your hedge cutter.
- Make sure the operator reads, understands and follows the instruction manual.
- Follow the manufacturer's instructions when hitching or unhitching the machine from the tractor. Do not stand in any position where you may be at risk of being crushed, eg in the area between the back of the tractor and the cutter.
- Make sure the machine is left in a stable position when it is removed from the tractor, using any stands or props provided, and securing it further if necessary.
- Do not carry out maintenance on the hedge cutter with the cutting arm/dipper arm raised, unless the arm is properly supported.
- Check the tractor is at least the minimum weight recommended by the hedge cutter manufacturer. Use ballast as necessary.
- Inspect the hedge before starting to cut and remove wire, bottles, cans and other debris. Check for any telegraph/electricity pole stays. Damaged stays should be reported to the relevant Telecoms Company/Distribution Network Operator.
- Use appropriate warning signs to alert others to the hedge-cutting operation where necessary.
- Work at a safe speed, taking account of the conditions (eg terrain, proximity to the highway, or obstacles).
- Use safe practices when work needs to be done near OHPLs. Flailhead units on some dipper arms can reach over 5.2 metres, the minimum height of OHPLs above ground level (see Further reading).
- Clear up debris after cutting if it could be a hazard to others.

Roadside hedges

Take extra care if you are hedge/verge cutting along a road. Consider what measures you will need to control the risks to other road users (eg vehicles, cyclists, pedestrians, or horse riders). For roadside work (on the public highway) there are other legal requirements. For example, there may be obligations to:

- display specific warning signs in defined locations where work is carried out;
- fit flashing beacons to tractors/machines;
- clear debris from paths and roads;
- restrict your working hours.

Consult your local authority highways department and the Department for Transport for advice (see Further reading).

Further reading

Traffic signs manual 2009. Chapter 8. Traffic safety measures and signs for road works and temporary situations. Part 2: Operations DfT ISBN 978 0 11 553052 4 <http://assets.dft.gov.uk/publications/traffic-signs-manual/traffic-signs-manual-chapter-08-part-02.pdf>

Working safely near overhead electricity power lines AIS8(rev3) HSE Books 2012 www.hse.gov.uk/pubns/ais8.htm

Further information

For information about health and safety, or to report inconsistencies or inaccuracies in this guidance, visit www.hse.gov.uk/. You can view HSE guidance online and order priced publications from the website. HSE priced publications are also available from bookshops.

This guidance is issued by the Health and Safety Executive. Following the guidance is not compulsory, unless specifically stated, and you are free to take other action. But if you do follow the guidance you will normally be doing enough to comply with the law. Health and safety inspectors seek to secure compliance with the law and may refer to this guidance.

This document is available at www.hse.gov.uk/pubns/ais21.htm.

© *Crown copyright* If you wish to reuse this information visit www.hse.gov.uk/copyright.htm for details. First published 10/12.

SAFETY & INFORMATION DECALS (Power Arms)

Power Arm machines are equipped with safety and information decals designed to warn of dangers, operational information and machine protection. Operators must understand the decals and heed all warnings. Keep decals in a good condition and replace immediately if they are damaged or missing.



1.



2.

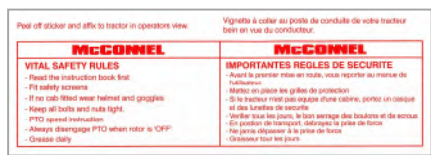

4.

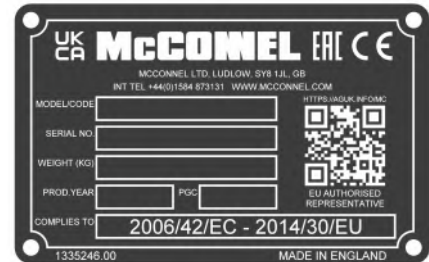

5.



6.



7.



8.



9.



10.



11.

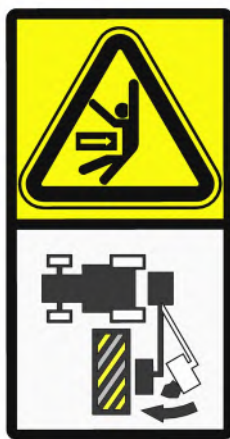

12.



13.



14.



15.

1. General Safety Warnings.
2. Driveline Hazard Warning.
3. Tighten Check Chains Warning.
4. 'In vehicle' Safety Rules Decal.
5. Serial Number Plate.
6. Read the Book First.
7. Lift Point with SWL (Kg).
8. Specific Pinch Point Warning.
9. Maximum vehicle PTO Speed & Direction Warning.
10. Oil Filter Initial and subsequent change information.
11. Lift Point for shipping only; stow when machine installed on vehicle. (Models with stowable lift eyes only).
12. Auto-breakaway Return Warning; in 'Auto-Reset' arm will automatically return to the work position, when possible.
13. Vehicle Clearance Warning; leave 300mm+ between arm and vehicle.
14. Lift Stop Clearance Warning; leave 300mm+ between arm and vehicle, leave 5mm between arm and stop.
15. Lift Tap 'Lock' Warning; leave 300mm+ between arm and vehicle, lock lift taps for transport.

SAFETY & INFORMATION DECALS (Flail Heads)

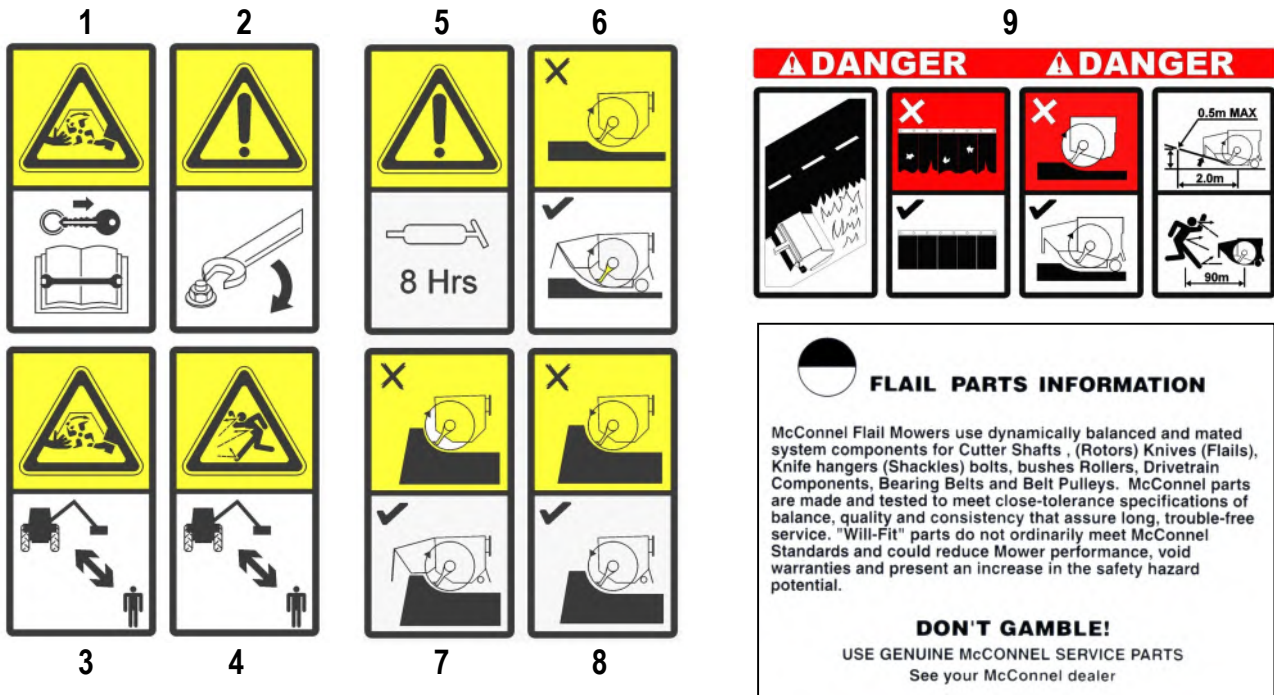

1. **Caution!** Rotating blades; keep clear of machine, stop machine (wait for rotor to stop), remove vehicle key and read the book first before performing any service or maintenance.
2. **Caution!** Keep all nuts and bolts tight.
3. **Caution!** Rotating components; keep clear of the working machine.
4. **Caution!** Thrown objects risk; keep all persons at a safe distance from the working machine.
5. **Caution!** Lubricate greasing points every 8 working hours.
6. **Caution!** Grass/Verge Mowing; front hood, front flap, rear roller and rear flap must be fitted and correctly adjusted when using the machine for grass and verge mowing. Flaps must be in good condition.
7. **Caution!** Hedging (Uphill cutting); front hood, front flap and rear flap must always be fitted and correctly adjusted. Rear roller should be placed into the raised position. Flaps must be in good condition.
8. **Caution!** Hedging (Downhill cutting); front hood may be removed; rear flap must be fitted and rear roller placed into the raised position. Flap must be in good condition.
9. **Danger!** Road side mowing. Flaps must be in good condition. Do not work if front hood, front flaps, rear roller and rear flaps not fitted. Front hood, front flaps, rear roller and rear flaps must be fitted. Adjust front hood to the correct height position for verge mowing. A extended straight line from the bottom of the rotor and bottom of the front flap should not be higher than 0.5m at a horizontal distance of 2.0m from the rotor. Keep all persons at 90m from the working machine, stop machine if persons are closer. *Refer to front hood height setting section for details.*
10. **Important!** Parts information; for safety and performance only use 'Genuine McConnell Service Parts'.

VEHICLE / TRACTOR REQUIREMENTS

Minimum Tractor Weights - including ballast weights if necessary

PA6085 models – 5000kg
PA6585 models – 5000kg
PA6585T models – 5500kg
PA7085T models – 5500kg
PA8085T models – 5500kg
PA6585T-VFR models – 5500kg
PA7285T-VFR models – 6000kg
PA8085T-VFR models – 6000kg
PA8085TT models – 6000kg
PA9085TT models – 7000kg

Minimum HP requirements

PA6085 models – 120HP
PA6585 models – 120HP
PA6585T models – 120HP
PA7085T models – 120HP
PA8085T models – 120HP
PA6585T-VFR models – 120HP
PA7285T-VFR models – 140HP
PA8085T-VFR models – 140HP
PA8085TT models – 140HP
PA9085TT models – 150HP

Linkage Type

Category 2

PTO Shaft

The tractor must be equipped with a 'live drive' PTO to allow the flailhead to continue to operate when tractor forward motion is stopped.

VFR Lock Tap - Pre-Operational Check

VFR machines are fitted with a security lock tap located on the control valve's reach gland port; this is to prevent the risk of arm movement during shipping of the machine.

Ensure the lock tap is fully opened before attempting to operate the machine.

The tap should be kept open and only closed for any future shipping or as an added safety precaution when storing the machine detached from the tractor.

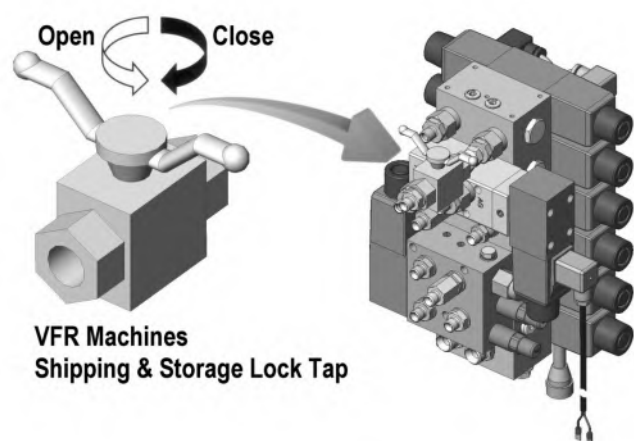

VEHICLE / TRACTOR PREPARATION

Guarding: We recommend vehicles are fitted with cabs using safety glass windows and protective guarding when used with our machines. Fit Operator Guard (*part no. 7313324*) using the hooks provided. Shape mesh to cover all vulnerable areas. Remember the driver must be looking through mesh and/or polycarbonate glazing when viewing the flail head in any

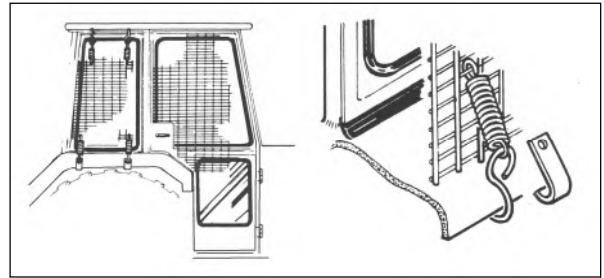

working position - unless the vehicle/ cab manufacturer can demonstrate that the penetration resistance is equivalent to, or higher than, that provided by mesh/polycarbonate glazing. If the tractor has a roll bar only, a frame must be made to carry both mesh and polycarbonate glazing. The operator should also use personal protective equipment to reduce the risk of serious injury such as; eye protection (mesh visor to EN1731 or safety glasses to EN166), hearing protection to EN352, safety helmet to EN297, gloves, filter mask and high visibility clothing.

Vehicle Ballast: It is imperative when attaching 'third-party' equipment to a tractor that the maximum possible stability of the machine and tractor combination is achieved – this can be accomplished by the utilisation of 'ballast' in order to counter-balance the additional equipment added.

Front weights may be required to place 15% of total outfit weight on the front axle for stable transport on the road and to reduce 'crabbing' due to drag of the cutting unit when working on the ground.

Rear weights may be required to maintain a reasonable amount of rear axle load on the opposite wheel from the arms when in work; for normal off-ground work i.e. hedge cutting this should be 20% of rear axle weight or more for adequate control, and for ground work i.e. verge mowing with experienced operators, this can be reduced to 10%.

All factors must be addressed in order to match the type and nature of the equipment added to the circumstances under which it will be used – in the instance of Power Arm hedgecutters it must be remembered that the machine's centre of gravity during work will be constantly moving and will differ from that during transport mode, therefore balance becomes critical.

Factors that effect stability

- *Centre of gravity of the tractor/machine combination.*
- *Geometric conditions, e.g. position of the cutting head and ballast.*
- *Weight, track width and wheelbase of the tractor.*
- *Acceleration, braking, turning and the relative position of the cutting head during these operations.*
- *Ground conditions, e.g. slope, grip, load capability of the soil/surface.*
- *Rigidity of implement mounting.*

Suggestions to increase stability:

- *Increasing rear wheel track; a tractor with a wider wheel track is more stable.*
- *Ballasting the wheel; it is preferable to use external weights but liquid can be added to around 75% of the tyre volume – water with anti-freeze or the heavier Calcium Chloride alternative can be used.*
- *Addition of weights – care should be taken in selecting the location of the weights to ensure they are added to a position that offers the greatest advantage.*
- *Front axle locking; a ram can be used to 'lock' the front axle in work only – locking the axle moves the 'balance line' and can be used to transfer weight to the front axle from the rear (check with tractor manufacturer).*

NOTE; The advice above is offered as a guide for stability only and is not a guide to tractor strength - it is therefore recommended that you consult your tractor manufacturer or local dealer to obtain specific advice on this subject, additionally advice should be sought from a tyre specialist with regard to tyre pressures and ratings suitable for the type and nature of the machine you intend to fit.

TRACTOR AXLE BRACKETS / CATCH ASSEMBLY – Fitting by Dealer

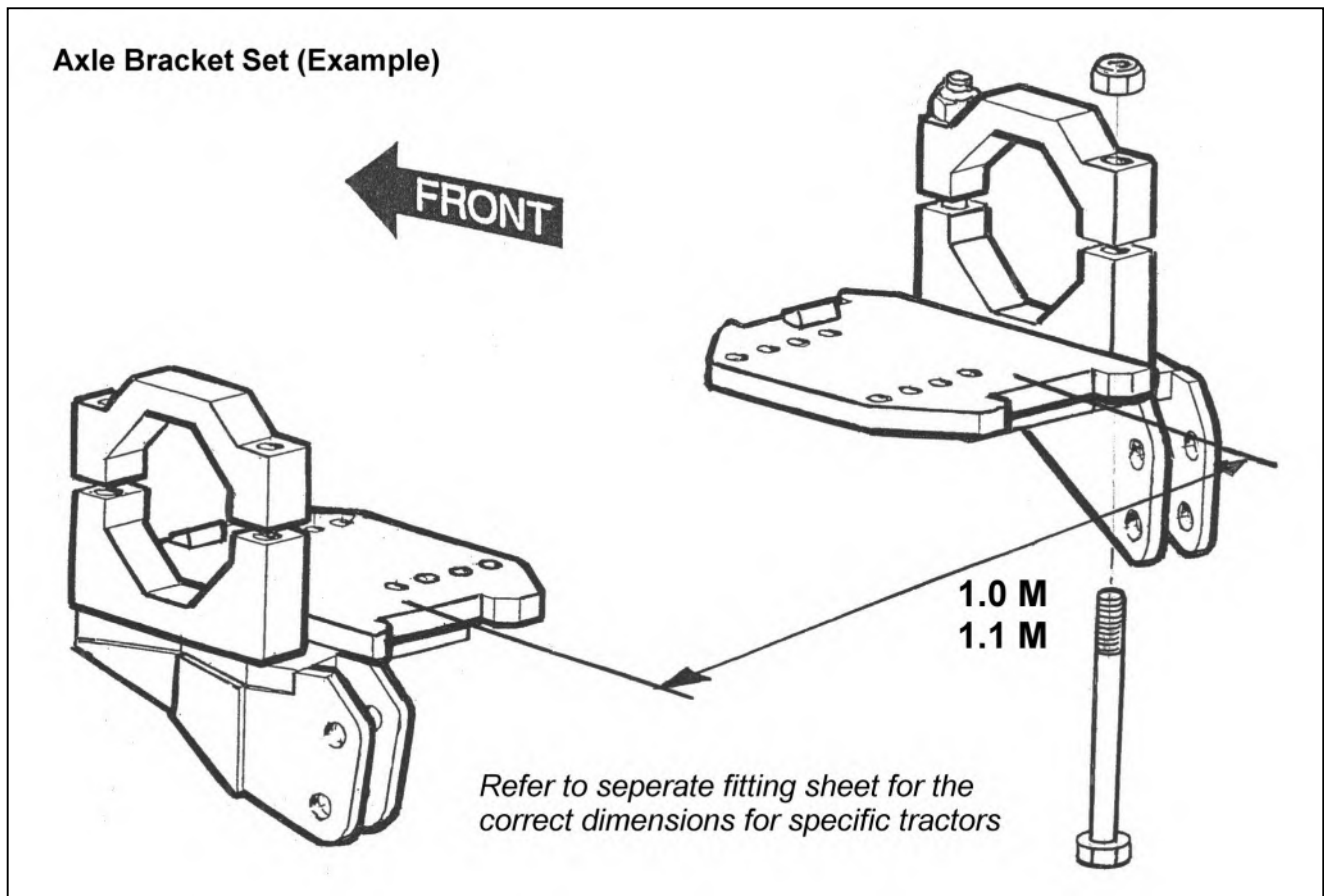

Bolt axle plates to the tractor axle at either 1.0m or 1.1m apart - this may necessitate the removal of the tractor's check chains and/or assister ram brackets, if this is the case, the axle plate will include replacement brackets for these functions.

The axle brackets supplied will be accompanied by a fitting sheet with instruction for their attachment to your tractor, follow the instructions exactly as they are specific to your particular make and model of tractor. Replace assister ram(s) if fitted.

Hook the catch assemblies onto the rear of the axle plates, push firmly against the plate and vigorously pivot the catch in a forward and up direction until the spring loaded hook 'snaps' into position. Pass the release cords up into the cab.

NOTICE

On some tractors fitted with auxiliary fuel tanks, there is insufficient space for the spring catches to be fitted, in these instances special axle brackets and catches with a 'pin on' facility are available on request.

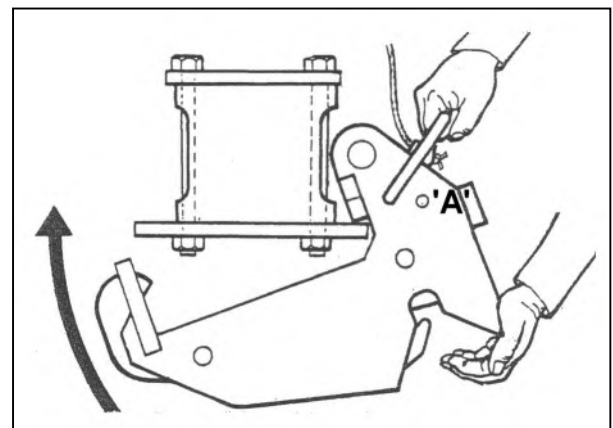

Ensure catch-locking pin 'A' is removed.

DELIVERY & PRE-ATTACHMENT (Dealer Reference)

Delivery

The machine will be delivered in a partially dismantled condition secured with transport straps and banding. Select a firm level site on which to place the machine before removing the straps, banding and other loose items.

Handling the Machine

Handling of the machine should always be performed using suitable overhead lifting equipment with a minimum safe lifting capacity over and above the maximum weight of the machine. Always ensure the machine is balanced during the lifting procedure and that all bystanders are kept well clear of the raised machine.

Lifting Points

To ensure even weight distribution when handling the machine it should be lifted using the sling eye at location 'A' and the sling shackle fitted at location 'B' for machines without a flailhead attached or location 'C' for machines with a flailhead attached – see *illustration below*.

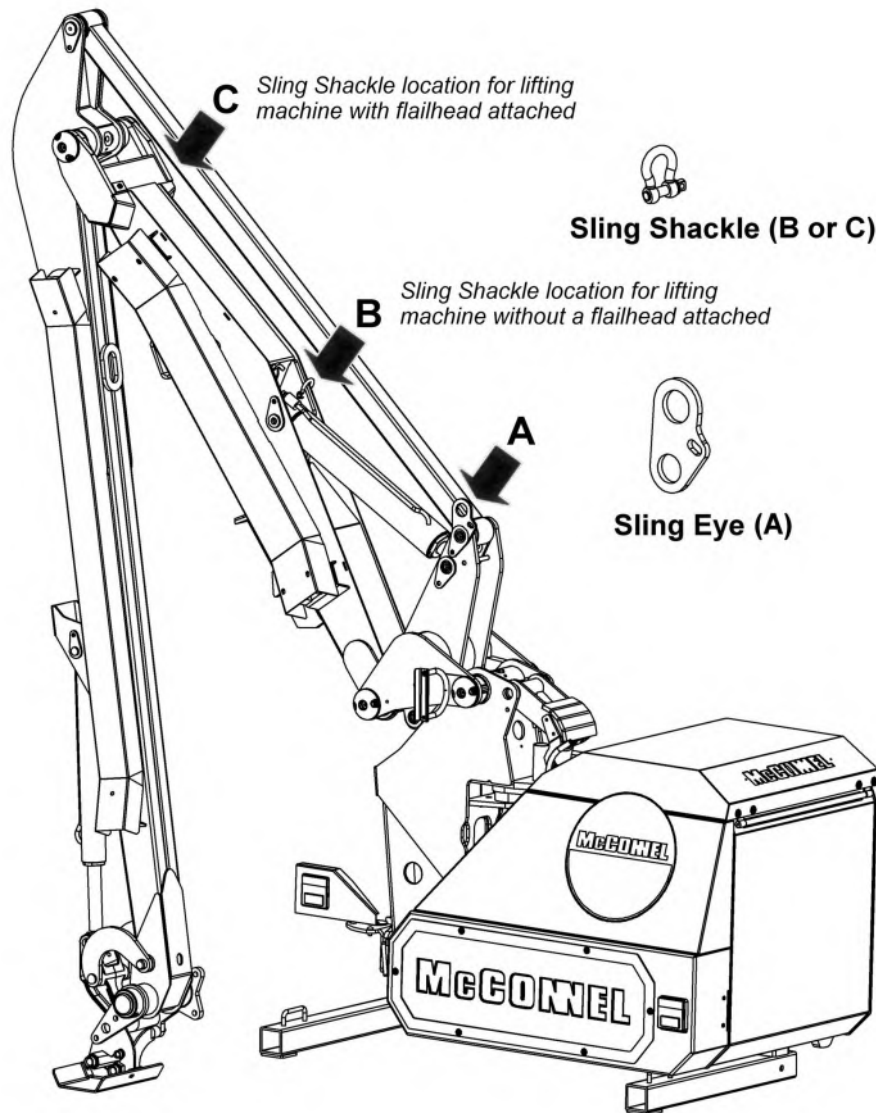

WARNING

Always place and secure the lifting eye on the machines rocker into its stowed position when not in use. **Never** attempt to operate the machine with the lifting eye out of its stowed position – failure to observe this may result in damage to machine components.

Post Delivery Assembly

To allow for a compact shipping state the machine will be delivered with the tension link disconnected from the rocker and the stand legs retracted – these items will need to be correctly installed before initial attachment to a tractor; the procedure is as follows:

Stand Legs

Raise the machine using suitable overhead lifting equipment.

Lower stand legs and secure in position using pins and locking pins – the hole position selected should be at a height that places the gearbox stub axle approximately 3" (75mm) below the height of the tractor's PTO shaft when the machine is at rest on the ground. Note the hole position used and ensure the equivalent one is used on both sides of the machine

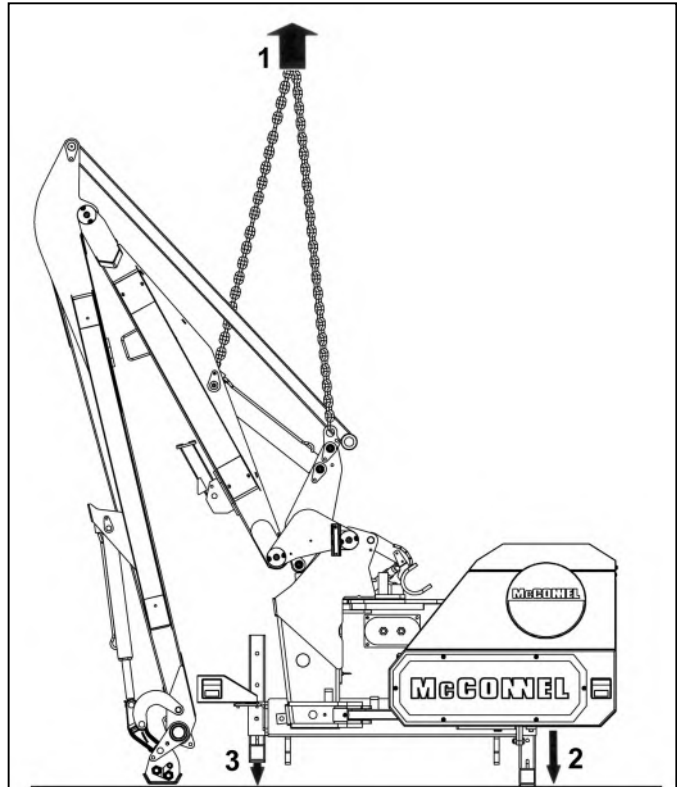

Tension Link Attachment

Request assistance for this task.

Operate 'lift up' on machine controls sufficient only for dipper arm to clear the ground.

Pivot out the dipper arm until the tension link can be connected and secure in position with pin and fixings supplied.

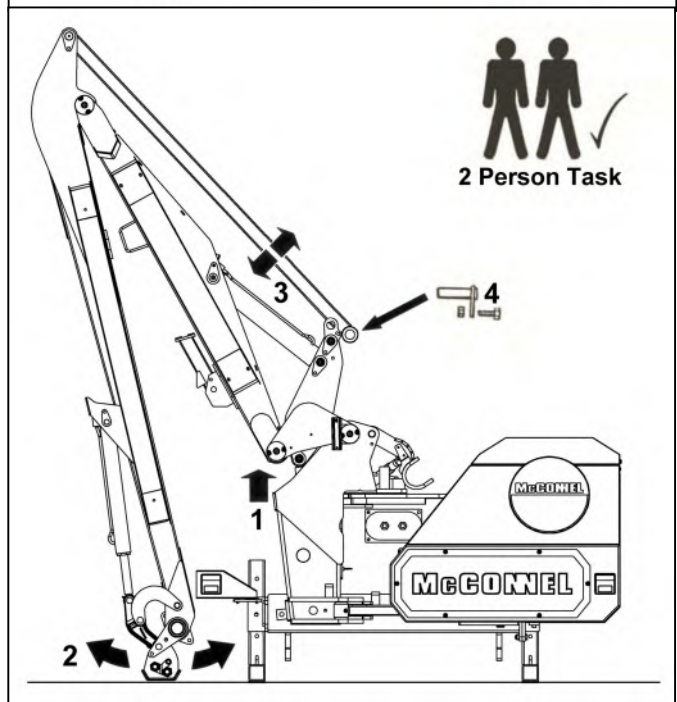

Axle Mounted Machines

If the machine is axle mounted, connect the mounting arms to the main frame using the nuts and bolts supplied. Tighten nuts when the correct holes have been determined.

See following page for details of mounting hole selection.

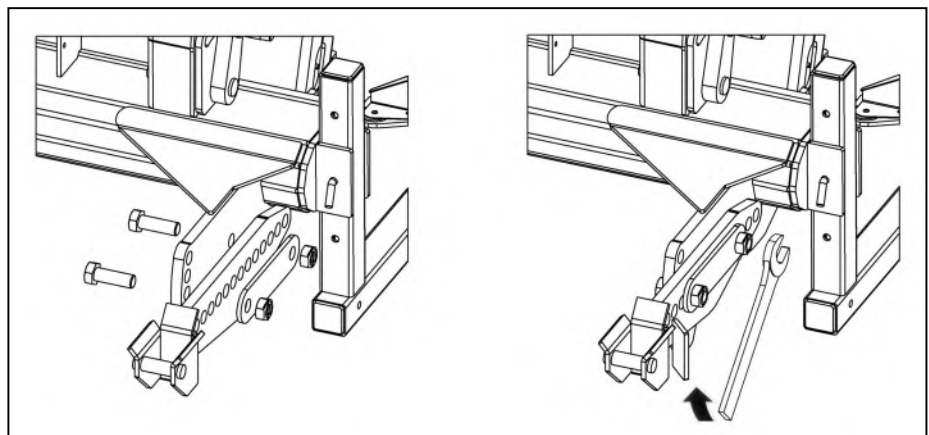

Positioning Axle Mounting Brackets

The correct mounting position is determined by the formula outlined below -

Note: in some cases certain tractors have a low PTO and/or small wheels and therefore have limited ground clearance, where this is the case, the operator must decide what is sufficient ground clearance for his needs; where there is insufficient ground clearance the latch arms can be pivoted down to a lower position. When doing this be aware that it will cause the PTO shaft to become mis-aligned - Ensure you do not exceed the angular mis-alignment allowed by the PTO shaft manufacturer and remember that this will reduce the working life of the shaft.

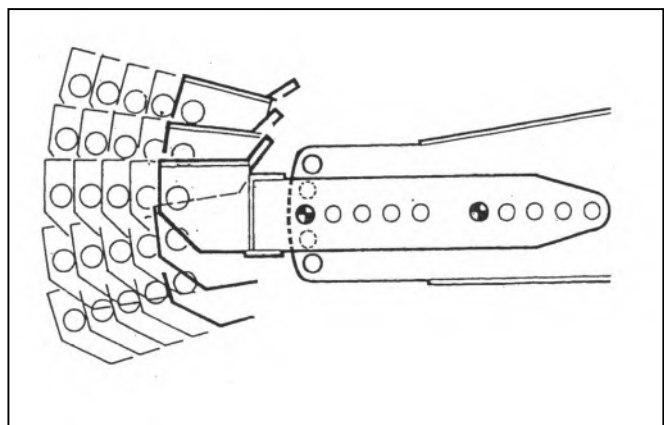
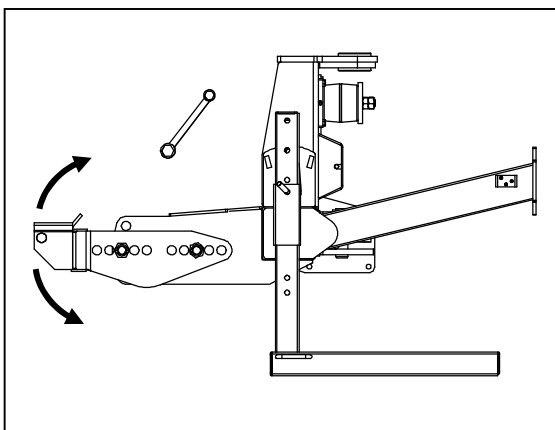
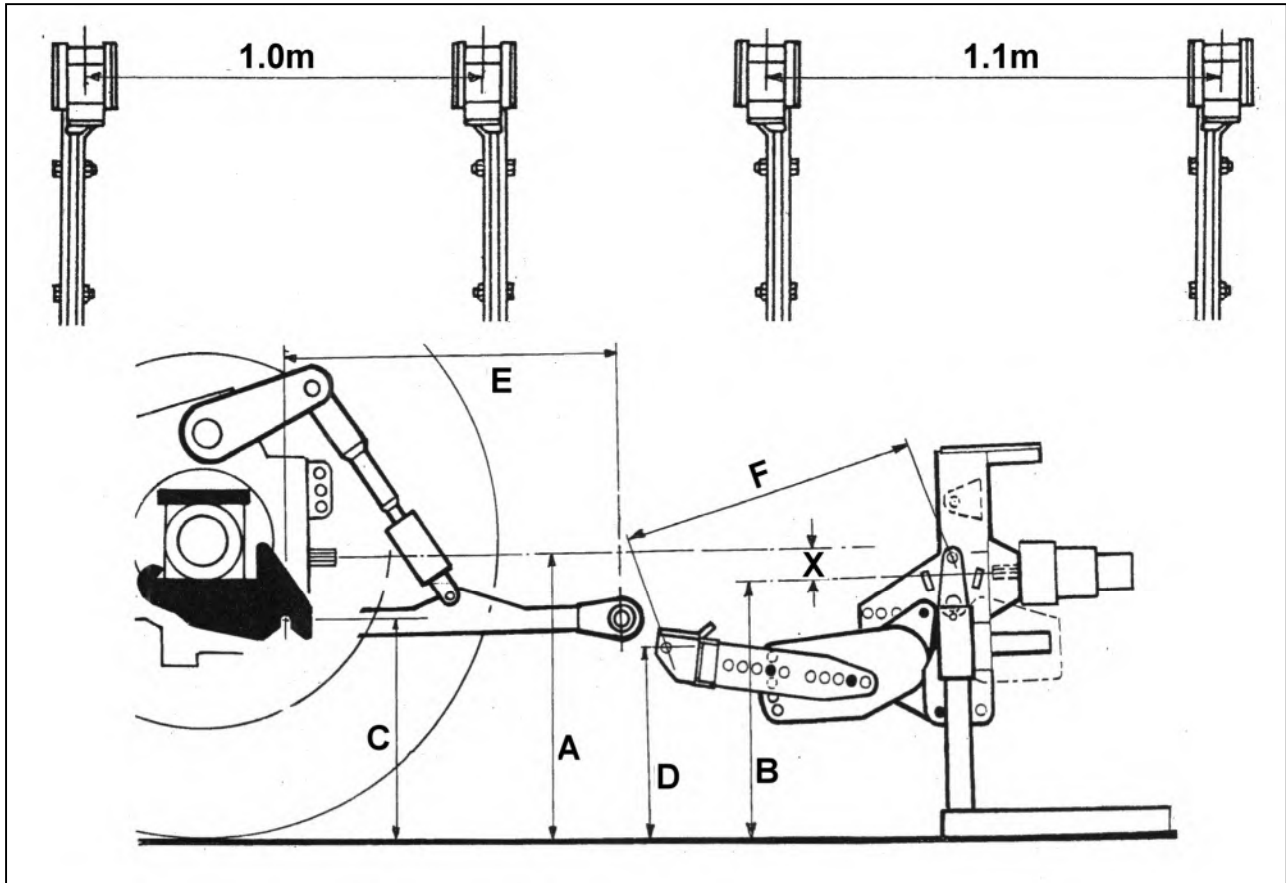

With the frame in the vertical position, measure dimensions 'A' and 'B', subtract 'B' from 'A' to obtain measurement 'X'. Measure dimension 'C'.

Select mounting holes which position the mounting bars in the end of the latch arms so that dimension 'D' equals dimension 'C' minus measurement 'X' and also when the draft link is horizontal and the rocking draft pin is in the upright position dimensions 'E' and 'F' are equal.

MACHINE ATTACHMENT – Axle Mounted Models

Generic illustrations used

Reverse tractor squarely into position adjacent to the machine and connect the draft links to the machine - *manoeuvre tractor until both draft pin rockers are vertical.*

The lifting equipment may now be removed.

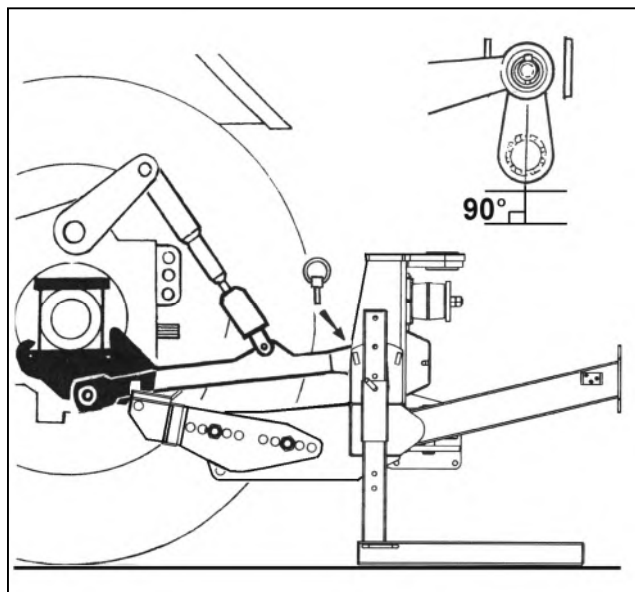

Raise the machine on the tractors linkage sufficient only for the latch bar to fully engage in the axle catch.

WARNING

The quadrant lever or machine controls must only be operated from the tractor seat. Ensure no one is standing close to or within the linkage arms or bars.

NOTICE

Be aware; as lift occurs the machinery may tilt slightly.

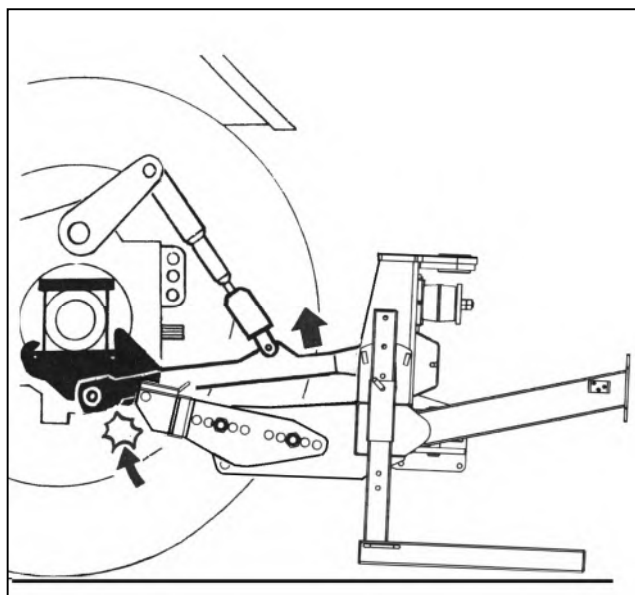

Insert catch lock pins.

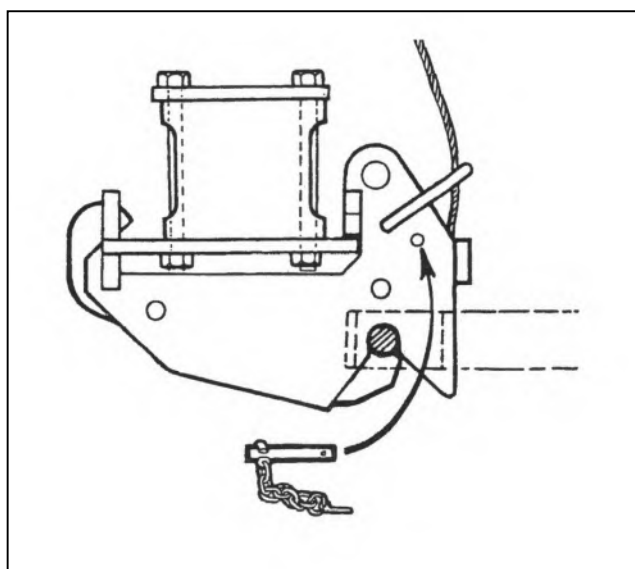

Raise the machine on the tractors linkage until the frame is vertical.

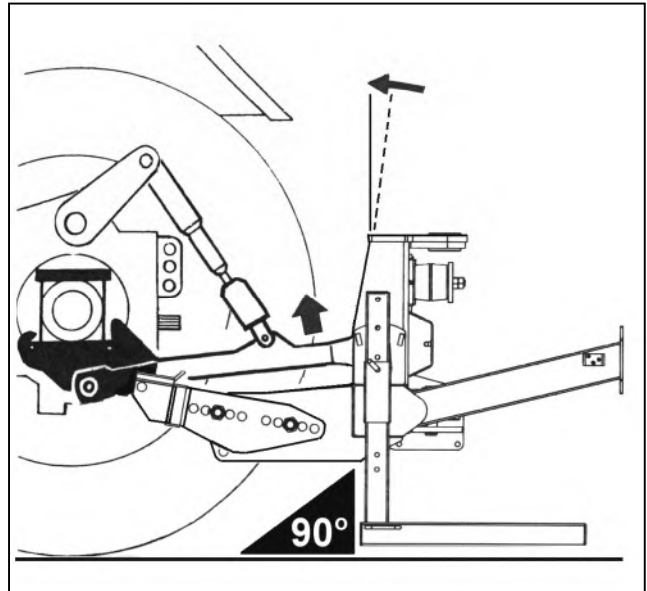

Fit top link.

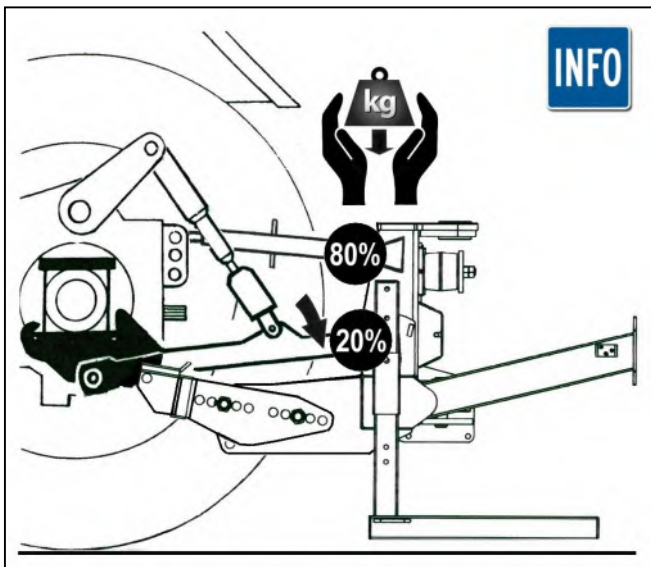
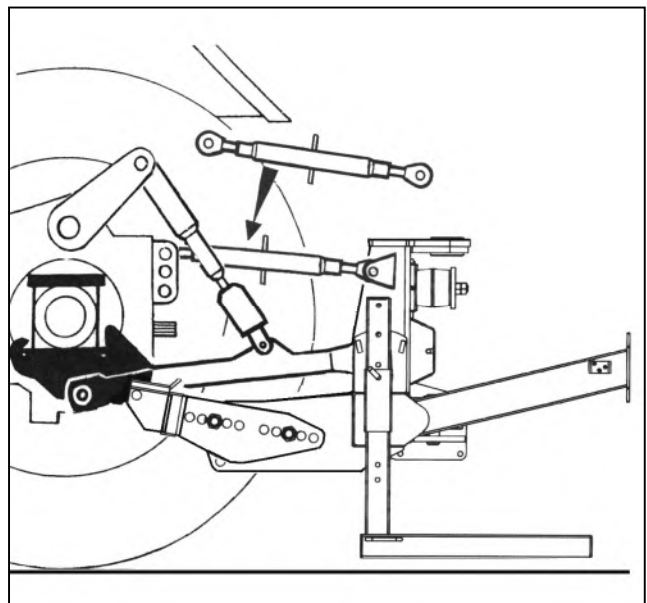

Lower the tractor link arms to transfer weight to the top link - **do not fully lower**.
For protection of upper connection points 20% of the machine's mass should be supported by the lower linkage.

On initial installation; measure PTO shaft and cut to the dimension shown opposite; refer to specific PTO section for additional information on this subject.

NOTICE

For subsequent use on a different tractor the PTO will need to be re-measured to ensure a minimum 6" (150mm) of shaft overlap, if unsuitable a replacement shaft will be required.

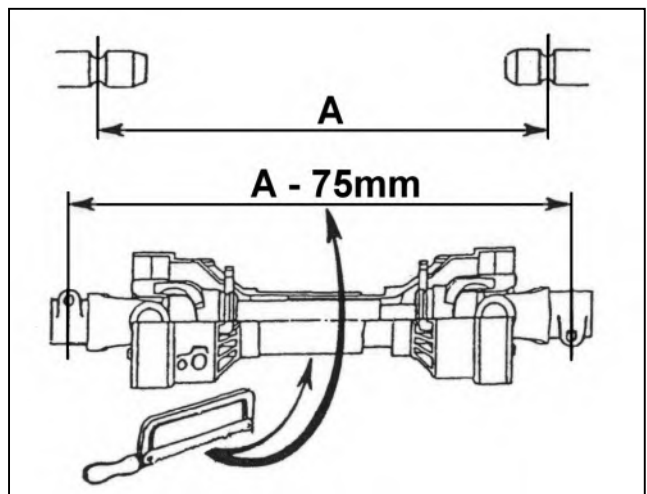

Fit PTO shaft in position.

Attach torque chains to a convenient location to prevent rotation of the shaft guards.

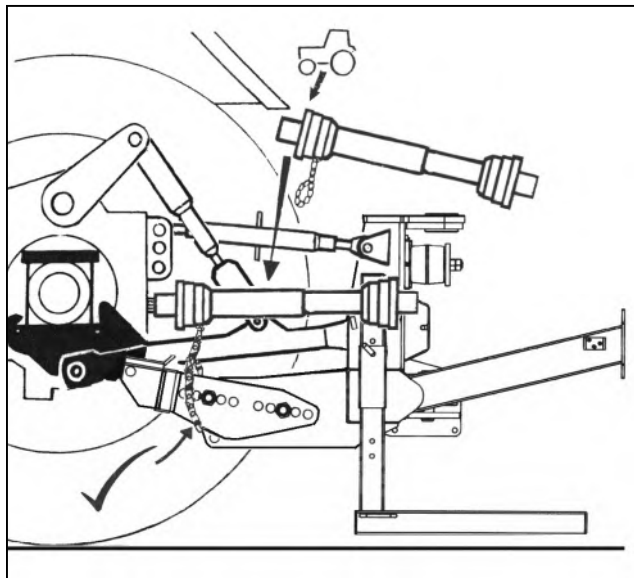

Fit machine controls into the cab.

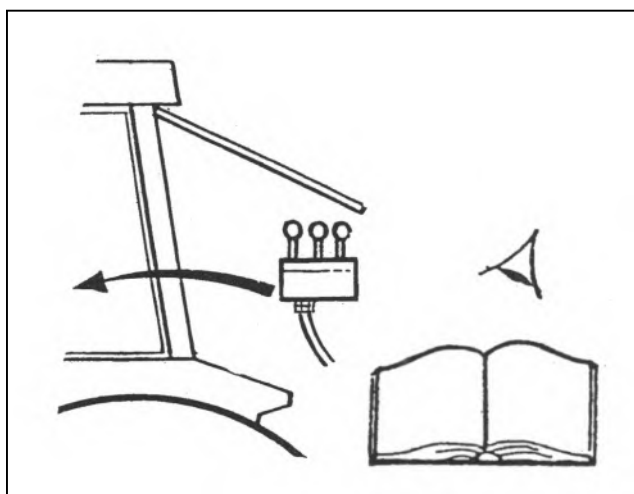

Raise the stand legs and stow into their work position, secure with locking pins.

NOTICE

On these models the stand legs are stowed in a storage cavity within the mainframe.

Tighten check chains and/or stabiliser bars.

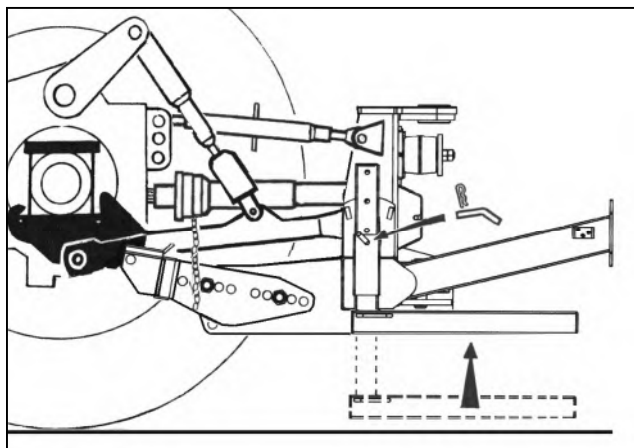

NOTICE

VFR Models with Security Lock Tap

Where fitted this lock tap must be opened before attempting to operate the machine – refer to page 11 for further details.

The machine should now be carefully operated throughout its full range of movements to check hoses are not being strained, pinched, chafed or kinked, and that all movements are functioning correctly.

The machine can now be folded into the transport position ready to proceed to the work site - refer to transport section for details on this subject.

STABILIZERS (3-Point Linkage Models only)

Standard Stabilizer Types Identification

As standard, 3-point linkage machines are fitted with either a 'slotted' type stabilizer or a 'multi-hole' type stabilizer; the particular one used is dependent on the specific machine build. Machines with Standard arm-sets use the 'slotted' type and machines with Midcut or VFR arm-sets use the 'multi-hole' type; *for identification refer to the illustrations below.*

Slotted Type Stabilizer

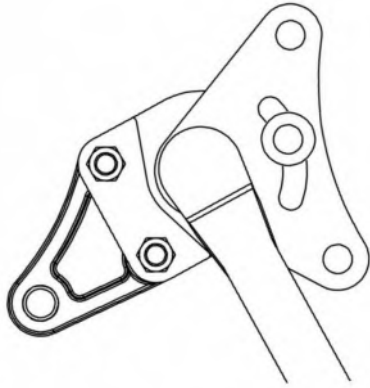

Machines with standard arm-sets.

Multi-hole Type Stabilizer

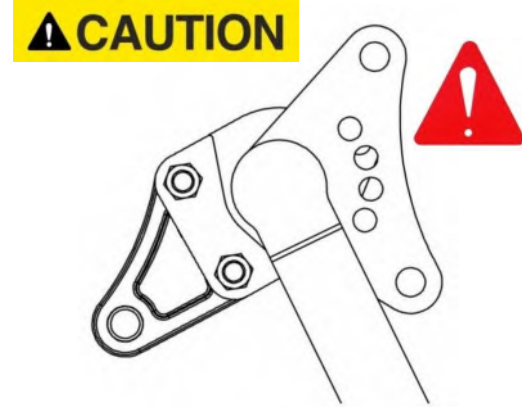

Machines with Midcut or VFR arm-sets.

CAUTION

On machines equipped with multi-hole type stabilizers it is vital that the stabilizer position pin is always removed for machine transport and only fitted for work; failure to observe this can result in serious damage to machine and/or tractor components.

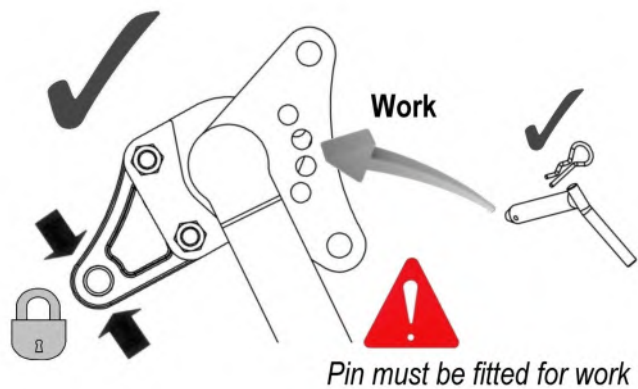
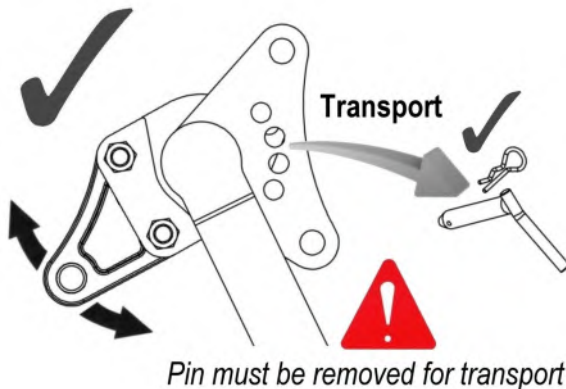

Position Pin Fitting & Removal (Multi-hole type stabilizers)

Insertion or removal of the position pin is best performed whilst the machine in its transport position as the forces acting on the stabilizer are greatly reduced; this will make the task of insertion or removal much easier. Always stow the position pin in a safe location when it is not in use.

Stabilizer Tongues

McConnel bolt on stabilizer tongues are available in a wide variety of versions to suit differing makes and models of tractors and are reversible to accommodate for greater variation in tractor linkage designs; *refer to following page for details.*

Stabilizer Tongue Options & Specifications

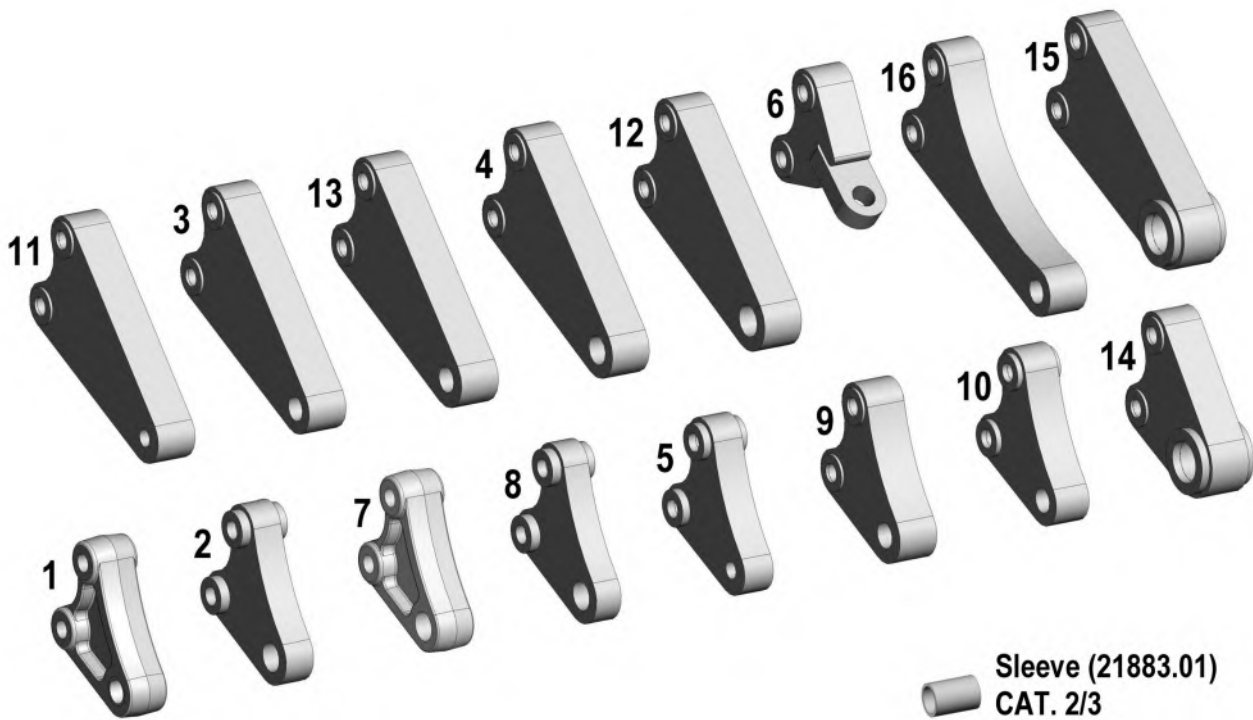

McConel Stabilizer Tongues

- 'A' – Hole diameter
- 'B' – Hole centre spacing
- 'C' – Stabilizer width

(Dimensions in mm)

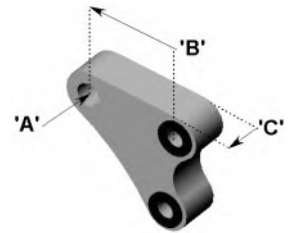

Ref.	Part No.	Description	'A'	'B'	'C'
1	7499501	Tongue: Standard CAT. 2/3	32.0	107.5	45.0
2	7499500	Tongue: Special CAT. 2/3 narrow	32.0	107.5	35.0
3	7499502	Tongue: Special CAT. 2 long	27.0	217.4	45.0
4	7499503	Tongue: Special CAT. 3 long	32.0	217.4	45.0
5	7499504	Tongue: Special CAT. 1	19.5	107.5	35.0
6	7499505	Tongue: Special CAT. 2 for Case TX tractors	25.0	120.0	50.0
7	7499506	Tongue: Special CAT. 3	32.0	107.5	45.0
8	7499507	Tongue: Special CAT. 3 narrow	32.0	107.5	30.0
9	7499508	Tongue: Special for some Ford tractors	28.6	107.5	45.0
10	7499510	Tongue: Special CAT. 2	27.0	107.5	40.0
11	7499511	Tongue: Special CAT. 1	19.5	217.4	45.0
12	7499512	Tongue: Special	35.0	217.4	45.0
13	7499513	Tongue: Special	28.6	217.4	45.0
14	7499514	Tongue: Special CAT. 4	45.2	107.5	63.5
15	7499515	Tongue: Special CAT. 4 long	45.2	217.4	63.5
16	7499262	Tongue: Special CAT. 2 extra long for Aebi	27.0	260.1	45.0

MACHINE ATTACHMENT – Linkage Mounted Models

Attachment of the machine should always be performed on a firm level site.

⚠ WARNING During the attachment procedure bystanders must be kept at a safe distance from the machine at all times. Never operate the tractors linkage system or machine controls when persons are standing on, or working between, the tractor and machine.

NOTICE Due to the close coupled design of the machine it is advisable to fit the PTO shaft to the machines gearbox stub axle prior to attaching the machine to the tractor. On initial installation the machine will need to be attached without the PTO fitted in order to measure for the required shaft length – In some cases the machine will then need to be removed from the tractor and subsequently refitted with the PTO pre-attached.

⚠ DANGER Operating external linkage lift controls.



If the tractor is equipped with external lift control the operator and all other persons must remain clear of the machine at all times when raising or lowering the machine on the tractor's linkage. **Never stand between tractor and machine.**

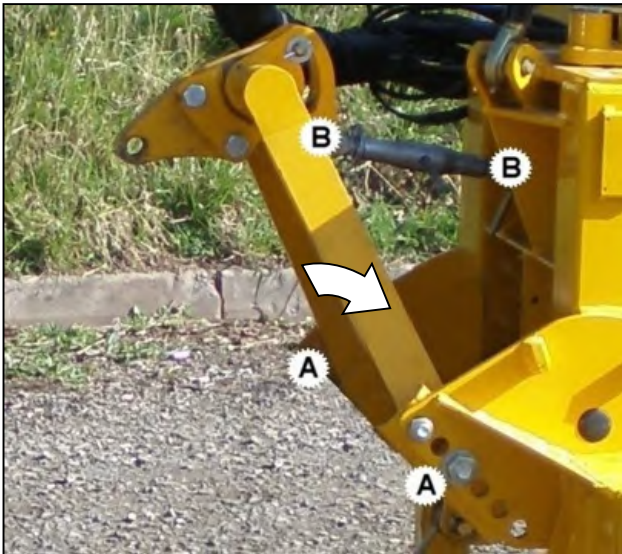

Attach stabiliser to machine frame at points 'A' - selecting a mid-point position initially – secure with nuts and bolts provided. Fit top link at points 'B' and secure with pins & lock pins.



Fit lower link balls and spacers into lower frame connection points and secure with linkage and lock pins – place spacers to position lower link balls for best alignment with tractor lower links.



Fit PTO shaft to the stub axle of the machines gearbox – **NOTE: for initial installation of a new machine or attachment to a different tractor refer to PTO note at top of page.**

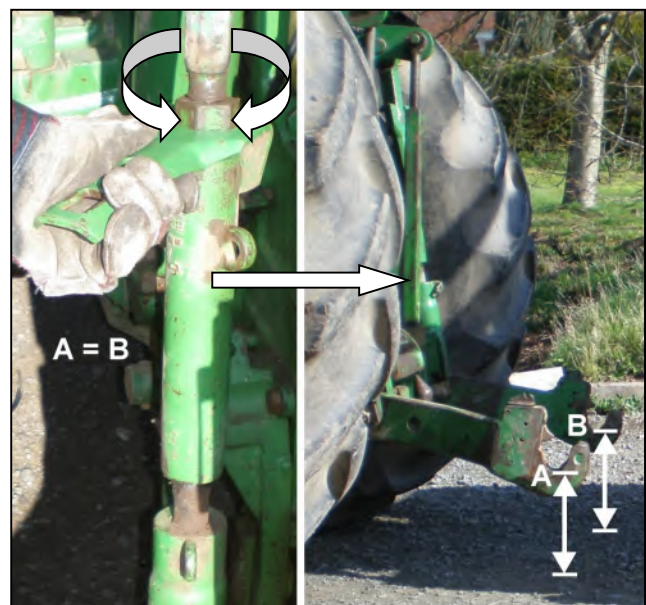

Adjust the drop arms so that lower links are level.

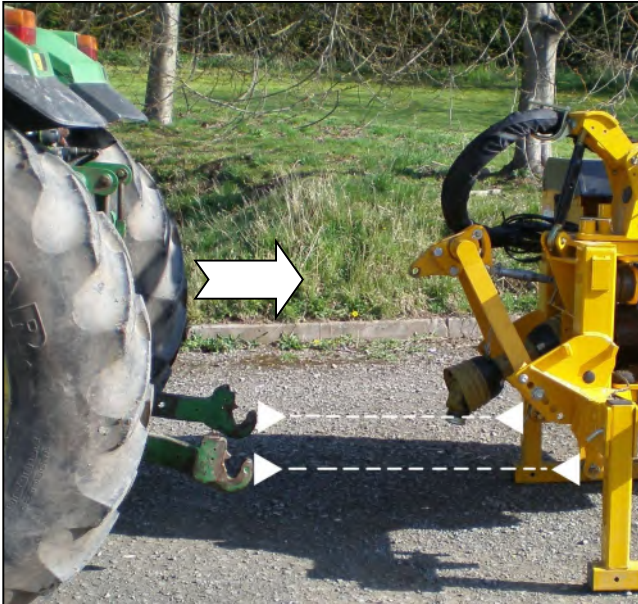

Reverse tractor squarely and centrally to the machine - set tractor lower links to a height that will permit attachment to lower frame attachment points.

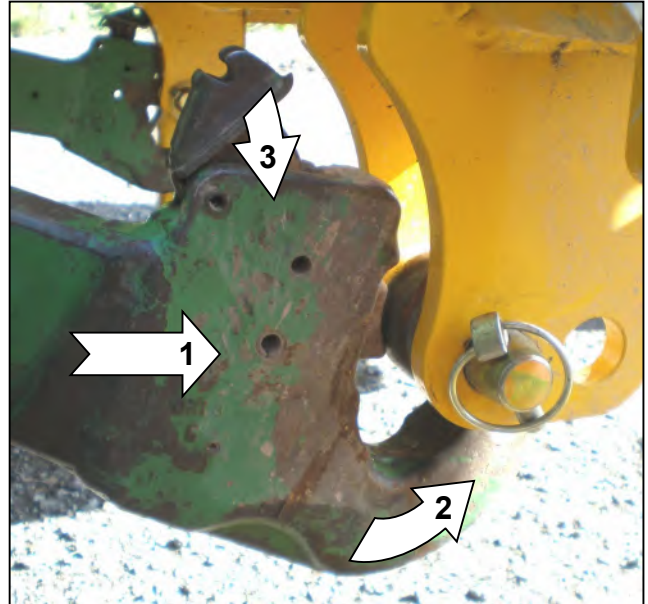

Reverse fully in to attachment points then raise the tractor linkage until it locks onto the lower link balls on both sides of the machine.



Adjust top link to position the stabiliser tongue for attachment to the tractors top link clevis. NOTE: Alternative tongues for stabilisers are available for differing applications.

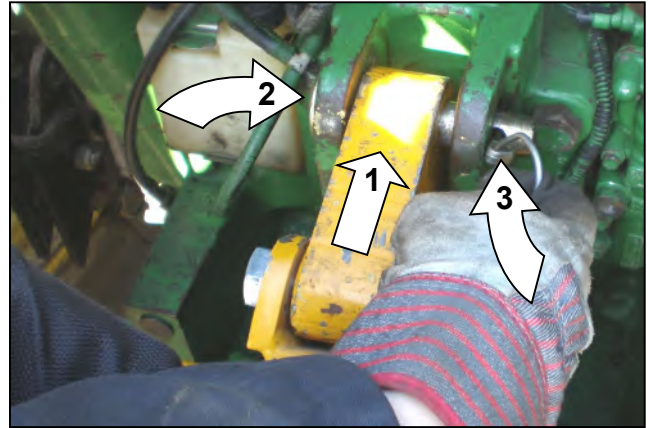

Attach stabiliser tongue to highest suitable clevis position that does not interfere with or foul tractor components - secure with pin and lock pin.

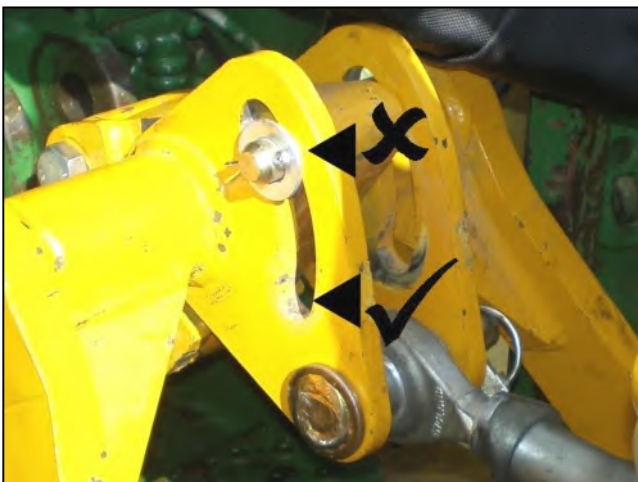

IMPORTANT: Rear of stabiliser tongue should be as close as possible to the bottom of the stabiliser slot with the machine at rest on the ground – if required change the stabiliser lower attachment points and/or clevis attachment position to achieve this setting. This is a vital requirement to ensure the tongue is located at the slots mid-point when the machine is raised to the work position thus allowing float in each direction.



Feed control lines into tractor cab – avoid sharp bends and keep lines well clear of all moving parts on the machine or tractor.



Connect control lines to the machines control unit in the tractor cab.



Tighten tractor stabilisers - raise tractor linkage to lift the machine to its working height.



Attach PTO shaft to the output shaft of the tractor.



Attach torque chains to convenient locations to prevent rotation of PTO shaft guarding.



Remove stand legs from both sides of the machine.

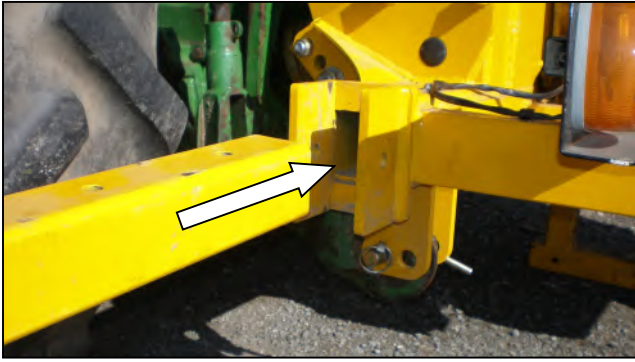

Stow legs upright in the storage cavity within the mainframe - secure in position with pins and 'R' clips.

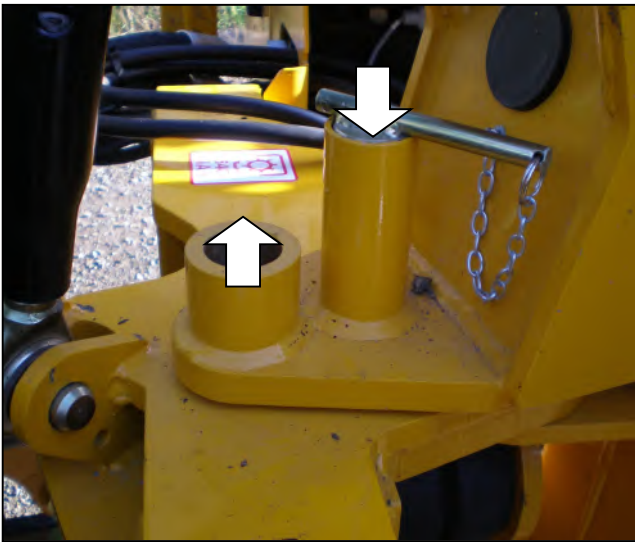
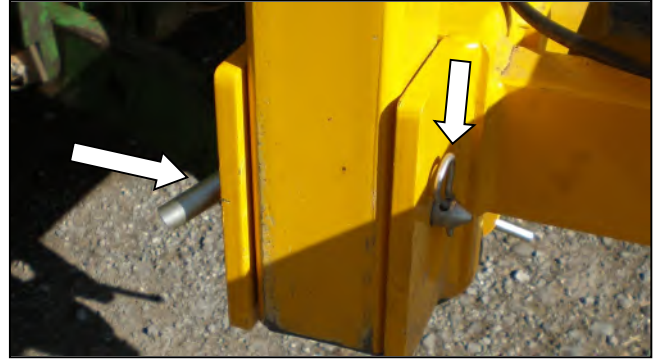

Remove and stow the slew lock pin (work mode).



Open lift ram tap - slew machine to the side of tractor in work position.

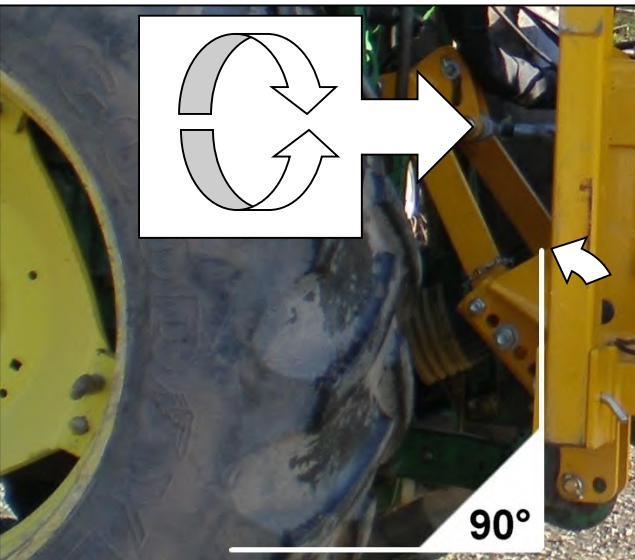

With machine in work position adjust the top link to bring machine frame into the vertical position.

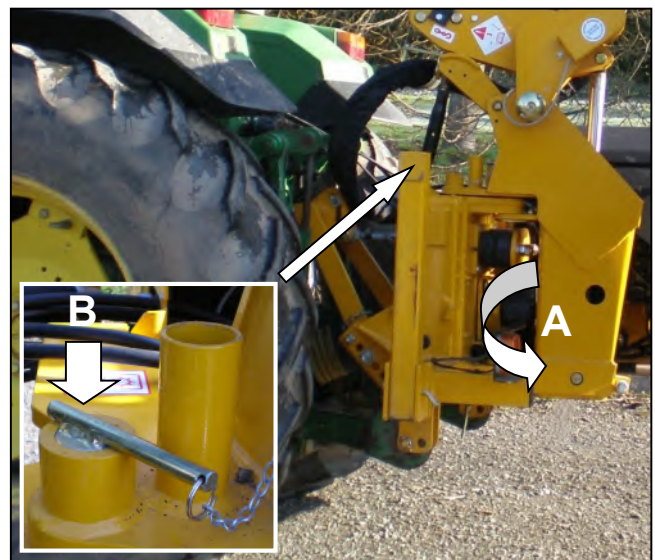

Slew machine into transport position and replace the slew lock pin (transport mode) Close lift ram tap.

NOTICE VFR Models with security lock tap; where fitted this lock tap must be opened before attempting to operate the machine – refer to page 27 for further details.

Attachment is now complete and the machine is ready for transportation to the work site.

CAUTION Multi-hole type stabilizers; remove position pin for transport.

NOTICE On initial installation refer to running up procedure.

PTO DRIVESHAFT INSTALLATION

The PTO driveshaft attaches between the tractor and the machine gearbox to transfer the power required to run and operate the machine – it is important to achieve the correct shaft length to avoid risk of it ‘bottoming out’ when raising or lowering the machine. The procedure for measuring and cutting the shaft is as follows:

Measuring the PTO Shaft

With the machine attached to the tractor in the working position measure the horizontal distance ‘A’ from the tractor’s PTO to the input shaft on the machine’s gearbox and subtract 75mm (3”) – *this figure is the required shaft length.*

Place the fully closed PTO shaft on the ground and measure its overall length, if the shaft is shorter than the required length you can use it without the need to shorten - *providing it allows for a minimum 150mm (6”) overlap when fitted.*

If the shaft is longer subtract the required shaft length plus an additional 75mm (3”) - *the resulting figure is the excess length that will need to be removed from each half of the shaft.*

Cutting the PTO Shaft

Separate the two halves and using the measurement obtained above shorten both the plastic guarding and the inner steel profile tubes of each shaft by this same amount. De-burr the cut tubes with a file to remove rough or sharp edges and thoroughly clean to remove swarf before greasing, assembling and fitting the shaft.

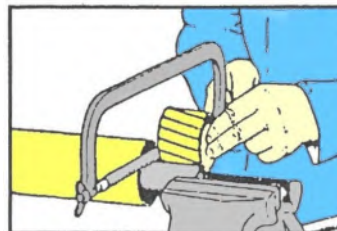
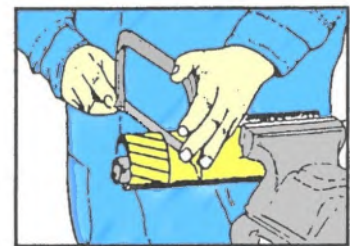
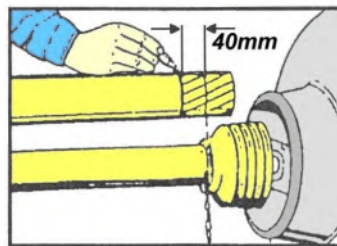
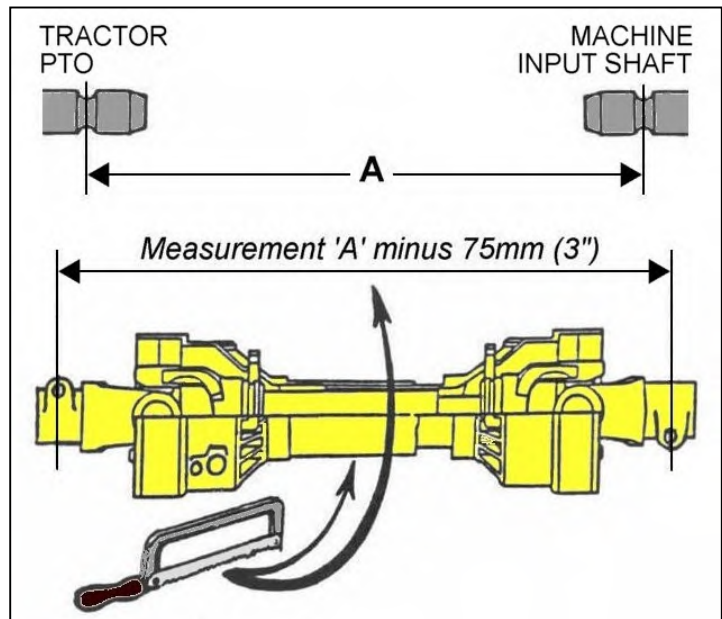

NOTICE

For subsequent use with different tractors the shaft should be measured again to check suitability – *there must be a minimum shaft overlap of 150mm (6”).*

Maintenance

To increase the working life of the PTO shaft it should be periodically checked, cleaned and lubricated – *refer to the PTO maintenance section for further details on this subject.*

CONTROL UNIT INSTALLATION

The information below states installation methods for fitting control units in the tractor cab.

NOTE: Electric control units work within the range of **12v-16v DC** and require a minimum power supply of **12v DC**.

Cable Controls

Cable control units are provided with, and attached to, a mounting bracket – the bracket should be securely fixed to the internal mud wing or cab cladding in a suitable convenient location that offers ease of use without interfering with normal tractor operation.

In deciding the final position of the control unit bear in mind the location of the cable run – make sure the minimum acceptable cable bend radii of 8" (200mm) is not exceeded.

Ensure during fitting that no structural member of the tractor cab or roll bar is drilled or damaged.

The cable rotor control valve lever on cable controlled machines will be assembled as a component part of the main bank of controls and therefore shares the same mounting bracket.

On electric machines with cable operated rotor control valve the lever will be supplied as a 'standalone' unit with its own individual mounting bracket – this should be fitted in the same manner as above adopting the same precautions pertaining to attachment and cable runs.

Electric Controls : Motion / Evolution

Motion and Evolution units feature an inbuilt mounting bracket for attaching the controls to the armrest of the tractor seat. An optional mounting kit (Part No. 22073.23) is available for Evolution control units if an alternative method of mounting is required.

The power supply cable should be connected directly to the tractors battery; do not use cigarette lighter type connections as these prove to be sporadic and unreliable for control applications. Control units are **12 volt DC** operated. The **brown lead is positive (+)**, the **blue lead is negative (-)**.

Electric Proportional Controls : v6 Mini-Revolution / v6 Revolution

Revolution proportional controls comprise of 2 units; the main control screen and the armrest control unit.

The control screen is supplied with a mounting bracket and suction cup assembly that allows the unit to be mounted on the window of the tractor cab; ensure the surface used is clean and dry and the unit mounted in a position where it does not obstruct operator vision.

The armrest unit is designed to slide over the armrest of the tractor seat and is held in place with the fixing straps provided. Alternately, the mounting bar of the controls can be used should a more permanent installation be required; when fitting the latter ensure that any holes drilled in the tractor cab are clear of any important components and/or electrical wiring and should not be located in any area where it could affect the safety structure of the cab or impede normal operation of machine or tractor.

The power supply cable should be connected directly to the tractors battery; do not use cigarette lighter type connections as these prove to be sporadic and unreliable for control applications. Control units are **12 volt DC** operated; the **red lead is positive (+)** and the **black lead is negative (-)**.

Operation of Control Units

Refer to the specific control manual supplied with the machine for operating instructions; users should read the controls operation manual in conjunction with the operation manual for the machine.

HYDRAULIC OIL

Hydraulic Oil Reservoir

Fill the tank with oil selected from the chart below or a good quality equivalent to a point where the level is between the minimum and maximum marks on the tank gauge. When the machine is initially run the level will drop as the oil is drawn into the circuit - *top back up as required to the correct level on the gauge.*

Always use clean receptacles when handling and transferring oil to avoid moisture or dirt contamination that can damage components and/or reduce machine performance.

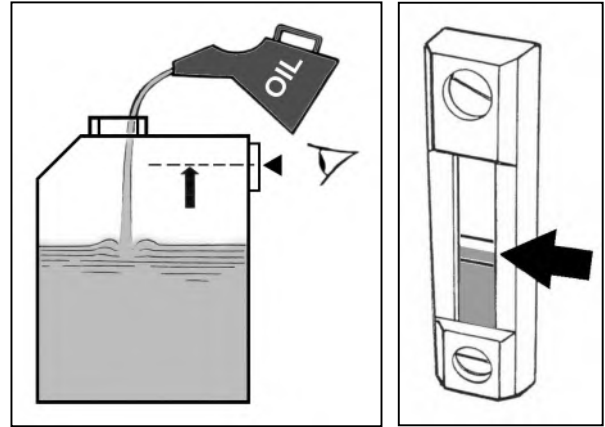

Refer to the maintenance section for further information on the subject of hydraulic oil and system filtration.

Reservoir Capacity

The oil tank capacity of the machine is approximately **225 Litres**.

Recommended Hydraulic Oils

For initial filling of the oil reservoir, periodic oil changes and replenishment purposes the following hydraulic oils, or a good quality equivalent are recommended.

NOTICE

Only use oils that are ISO 18/16/13, NAS7, or cleaner.

Manufacturer	Cold or Temperate Climate	Hot Climate
BP	Bartran 46 Energol HLP-HM 46	Bartran 68 Energol HLP-HM 68
CASTROL	Hyspin AWH-M 46	Hyspin AWH-M 68
COMMA	Hydraulic Oil LIC 15	Hydraulic Oil LIC 20
ELF	Hydrelf HV 46 Hydrelf XV 46	Hydrelf HV 68
ESSO	Univis N 46	Univis N 68
FUCHS (UK/Non UK markets*)	Renolin 46 Renolin HVZ 46 Renolin CL46/B15* Renolin AF46/ZAF46B*	Renolin 68 Renolin HVZ 68 Renolin CL68/B20* Renolin AF68/ZAF68B*
GREENWAY	Excelpower HY 68	Excelpower HY 68
MILLERS	Millmax 46 Millmax HV 46	Millmax 68 Millmax HV 68
MORRIS	Liquimatic 5 Liquimatic HV 46 Triad 46	Liquimatic 6 Liquimatic HV 68 Triad 68
SHELL	Tellus 46 Tellus T46	Tellus 68 Tellus T68
TEXACO	Rando HD 46 Rando HDZ 46	Rando HD 68 Rando HDZ 68
TOTAL	Equivis ZS 46	Equivis ZS 68

DETACHMENT - Axle Mounted Machines

Removal of the machine must always be performed on a firm level site. Keep all bystanders at a safe distance from the machine.

⚠ WARNING

Never stand between tractor and machine with the tractor running or when operating the tractor's draft links. Ensure hydraulics are set to position control.

- Fit and secure the machine's parking legs.
- Position the arms at approximately half reach directly to the rear of the machine with the flail head approximately 600mm (24") off the ground.
- Remove axle latch security pins.
- Take machine's weight on draft links sufficient to allow the top link to be disconnected, then remove the top link.
- From the tractor cab; release the latch catches by pulling their cords.
- Operate the draft links to lower the machine to the ground. *Check PTO is still fully engaged.*
- Level the machine by gently pushing the flailhead downwards against the ground using the machine's controls.
- Disconnect draft links, PTO shaft and remove the control unit from the tractor cab. Store electric control units in a warm, dry and clean environment.
- Carefully drive tractor clear of the machine.

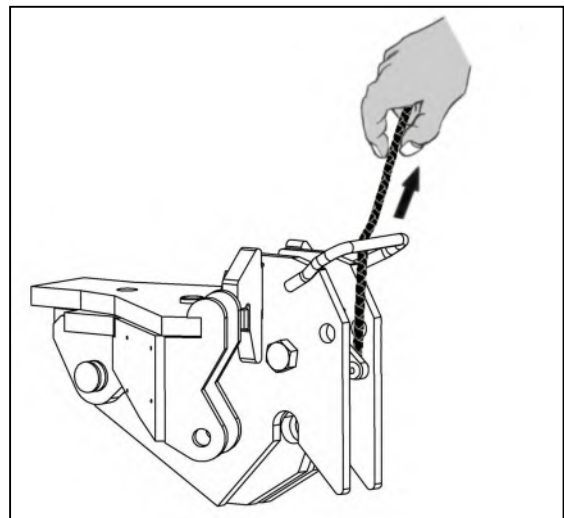
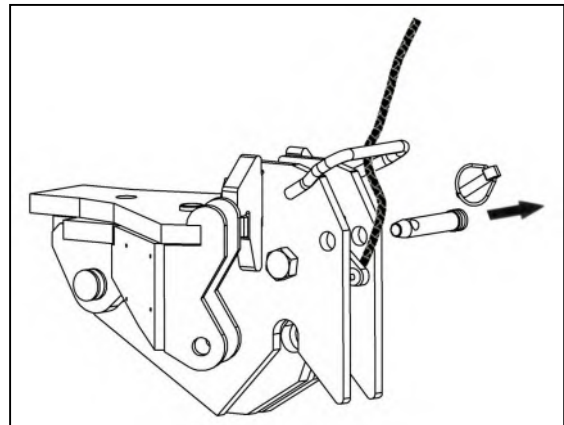
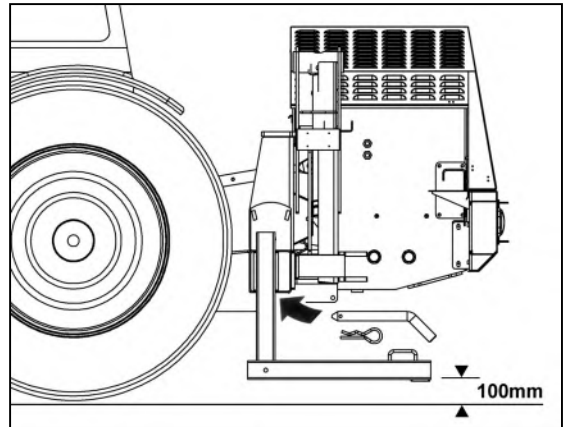

Hitch Types & Removal

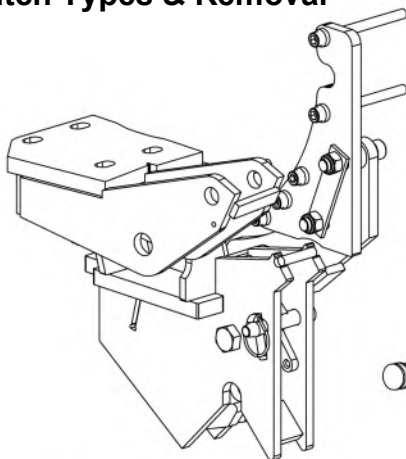

Integral (fixed) Hitch

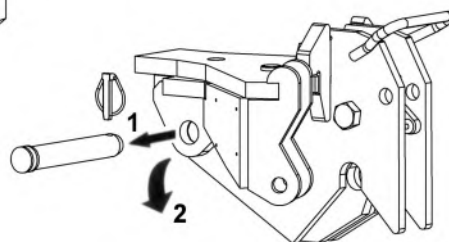

'Pin On' Hitch

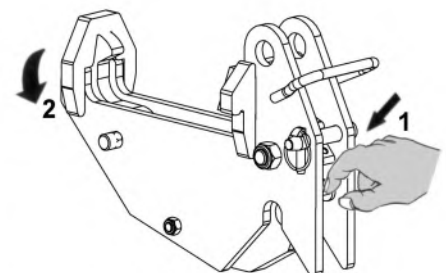

'Lift In' Hitch

Illustrations show the 3 different types of hitches used on axle mounted machines and the removal method for 'non-fixed' versions.



⚠ DANGER

Read carefully before attempting to detach the machine from the tractor.

⚠ WARNING

Do not operate quadrant lever or machine controls through the rear cab window whilst standing on or amongst linkage components – Always seek assistance.

Detachment Procedure

Select a firm level site on which to park the machine.

- Remove stand legs from their stowage location and fit in their parking position – secure in position with pins and ‘R’ clips.
- Lower machine to rest on the stand legs.

Ensure lift float is turned off (*where applicable*).

- Raise machine on tractor linkage enough only to take the weight off the stabiliser.
- Open lift ram taps.
- Ensure arm is in the rear position, place flailhead on the ground at half reach – push down slightly to relieve the load on the top link.
- Stop tractor engine.
- Close lift ram taps.
- Disengage PTO and remove from tractor.
- Slacken stabiliser bars/check chains as applicable.
- Disconnect controls and/or control lines from the tractor cab and stow neatly on the machine clear of the ground.
- Disconnect stabiliser from tractors top hitch point.
- Remove draft link pins.
- Slowly and carefully drive the tractor away from the machine.

Storage

If the machine is to be left standing for an extended period of time, lightly coat the exposed portions of the ram rods with grease. Subsequently, this grease should be wiped off before the rams are next moved.

Wherever possible storage of the machine should ideally be in a clean dry location, if the machine has to be stored outside tie a piece of tarpaulin or canvas over the control assembly, do not use plastic bags as these can lead to rapid corrosion of the unit.

FLAILHEAD ATTACHMENT

For ease of attachment and safety this procedure is best performed on a firm level site. With the tractor parked alongside the flailhead operate the controls of the machine to position the pivot bracket of the machines head angling mechanism directly behind flailhead with the base of the hose tray (or junction bracket) parallel to the ground. Manoeuvre the flailhead backwards on its roller until the heads attachment bracket is adjacent to the machines pivot bracket. Fit the 4 attachment bolts through the brackets from the arm side - *if the holes are mis-aligned carefully operate the angling ram until the holes correspond.*

⚠ WARNING Ensure all persons remain at a safe distance whilst operating the angling function as the geometry of the head angling mechanism produces several pinch risk areas.

With the attachment bolts correctly located through the brackets fit the self-locking nuts and tighten alternately until the brackets are drawn flush before finally tightening them to a torque setting of 203Nm (150ft.lbs).

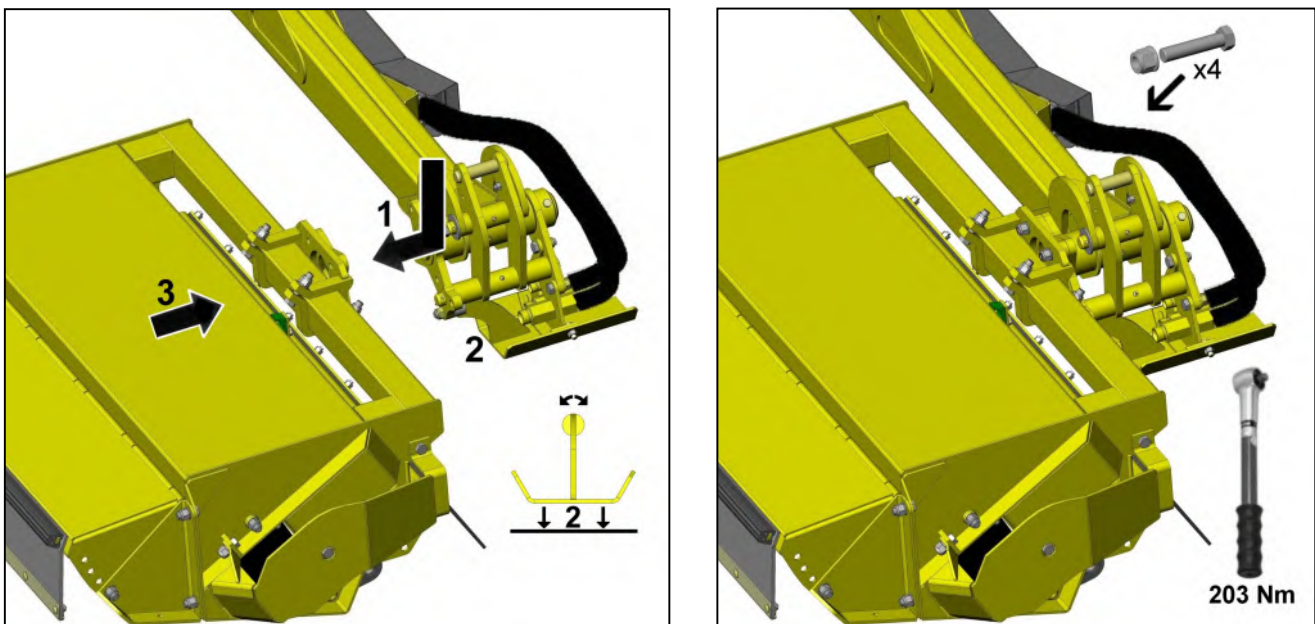

Flailhead Hose Attachment

With the flailhead attached to the machine the hydraulic hoses can now be connected – *refer to diagrams opposite.* Upper port 'A' on the motor connects to junction bracket point 'A' on the arm and lower port 'B' on the motor connects to junction bracket point 'B' on the arm.

NOTICE

If a hose tray is already fitted to the arm it will need to be removed to allow the hoses to be connected to the junction bracket – ensure the hose tray is replaced once the hoses have been connected.

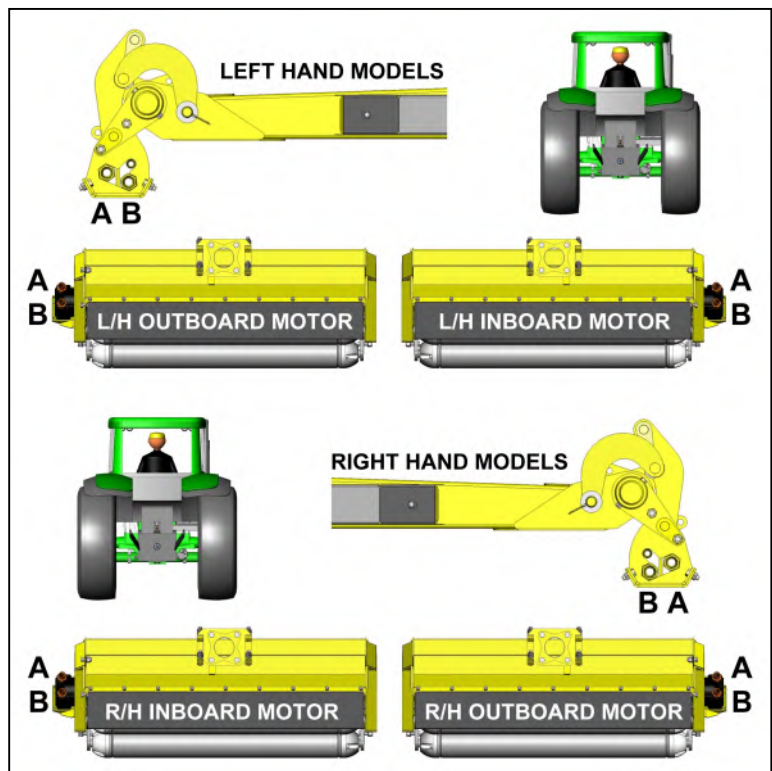

OPERATOR CONTROL SYSTEMS

Control System Operation Manual

For electrically controlled machines a dedicated operation manual for the specific control unit shipped with the machine is issued alongside this manual; **the control unit operation manual supplied must be read in conjunction with this manual** and should ideally be kept in the tractor cab for reference by the operator.

Control Unit Identification

Depending on specification the machine will be operated by one of the following controls;

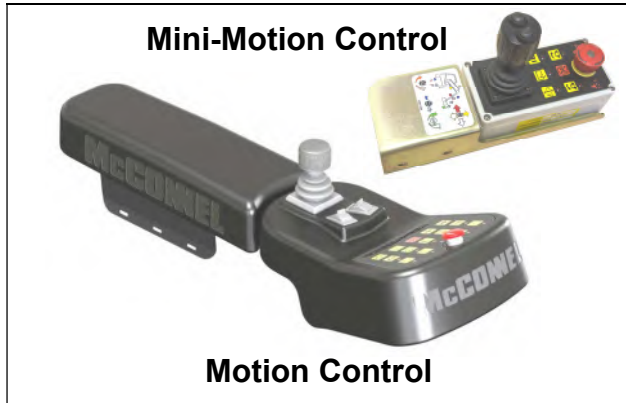

Users of this machine must read the specific control unit operation manual supplied with the machine in conjunction with this manual.

Control unit operation manuals are also available on our website for reference or download at; <https://www.mcconnel.com/support/parts-and-operators-manual/> or via QR code below.



OPERATION

Operator Guard

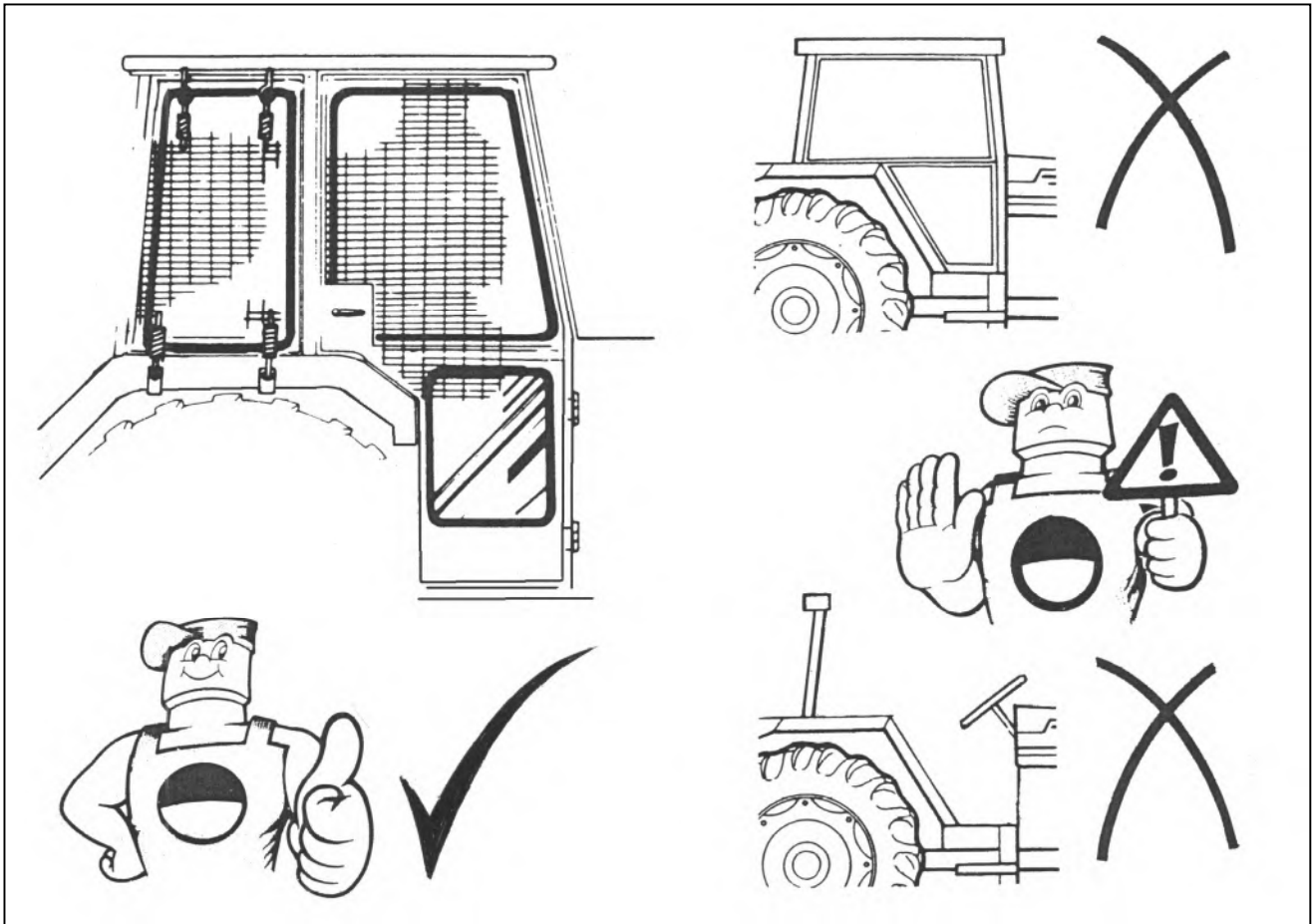

Machine Guards

Before each period of work, check that all the relevant tractor and machine guards are in place and in good working condition.

Small splits and abrasions on the lower edges of the flail head rubber flaps are permissible, but should one or more of these cuts or splits become fifty per cent or more of the flap height they should be replaced immediately as they will have become ineffective for debris containment.

Operator Safety

During operation all the tractor windows should be kept firmly closed with the exception of the rear window which may be opened only to the extent that is sufficient to allow entry of electrical or operating cables for the machine into the cab.

Should the tractor not be fitted with a 'quiet' cab ear defenders must be worn at all times, failure to heed this warning may result in permanent damage to hearing.

Although in normal circumstances a working machine or rotating parts should never be approached it is an additional wise precaution to avoid wearing loose or flapping clothes especially scarves and neckties whilst in close proximity to a machine.

The operator should continually guard himself and others from complacency that can arise from familiarity. Never attempt to take 'short cuts', always follow the correct procedures diligently and abide by the restrictions imposed by safety considerations.

REMEMBER: there is only one right way - the safe way!

SLEW & LIFT LOCKS

Slew Lock (Pin Type)

The machine is fitted with a 'pin type' slew lock – the pin locates through the pillar into the top of the mainframe to lock the position of the arms for transport or storage.

The slew function must be 'locked' at all times during transportation and storage of the machine and only unlocked for work.



Slew Locked – always for transport & storage



Slew Unlocked – only for working

There are 2 holes positions available on the top of the mainframe for locking the slew; one for standard and Tele arms and one for Midcut arms, ensure the correct hole is selected for your particular machine – refer to illustrations below (left-hand machine shown).

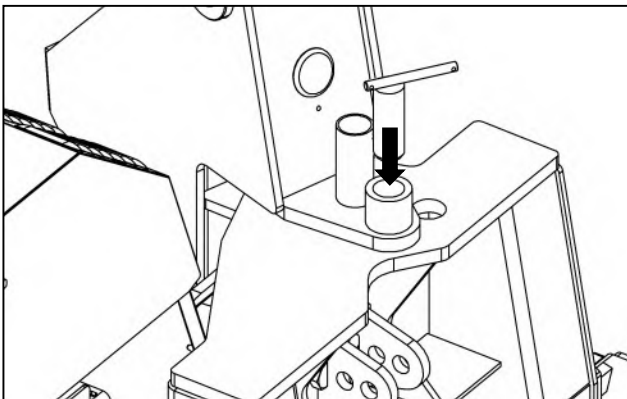

Midcut Arms Slew Lock Position

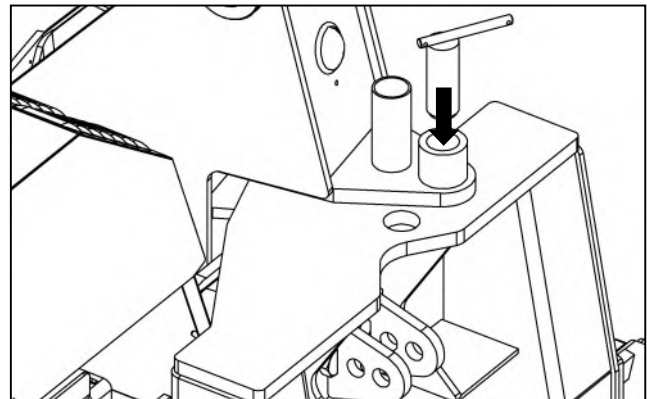

Standard & Tele Arms Slew Lock Position

Lift Ram Lock

The machine is fitted with two lift ram lock taps which must always be closed during transportation and storage of the machine to prevent movement of the arms.

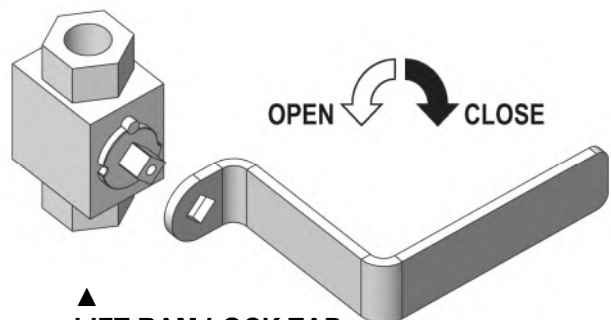

LIFT RAM LOCK TAP
Open – only for working
Closed – always for transport & storage



WARNING

Slew and Lift Locks must be in the closed / locked position at all times during machine transportation and storage – open / unlock only for work.

MOVING INTO TRANSPORT POSITION

- Select 'Rotor Off' and wait for the rotor to stop turning completely.
- Ensure that both 'lift' and 'angle float' functions are switched off.
- Select 'slew' mode on the controls.
- Operate 'slew in' function to bring the arms into position directly behind the tractor.

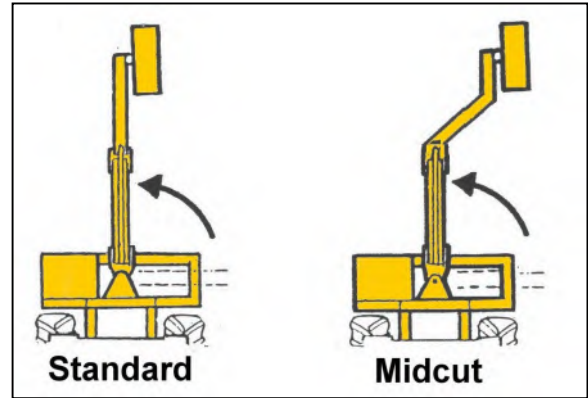

- Operate 'lift' and 'reach' to position the as shown in the diagram opposite.

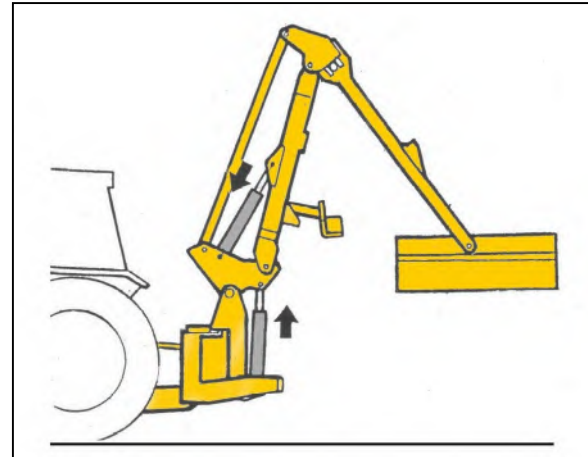

- Place transport prop into the transport position



Work Position



Transport Position

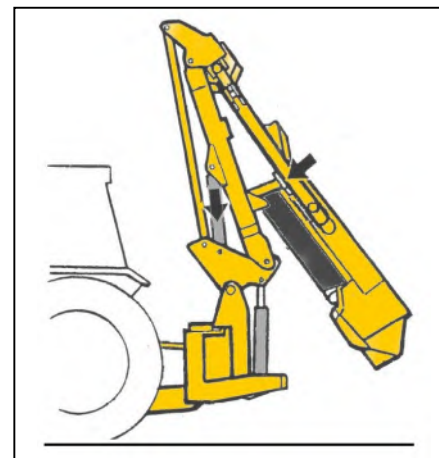

- Operate 'reach in' until the dipper arm contacts the transport prop.
- Select 'lift up' and raise the arms until the tension link is 300mm (12") from the tractor cab.
- Operate 'angle' to move the flailhead into a position where it is as compact as possible.
- Close lift ram taps.
- Fit slew lock pin.
- Disengage the PTO shaft.
- Ensure power to the control unit is switched off.

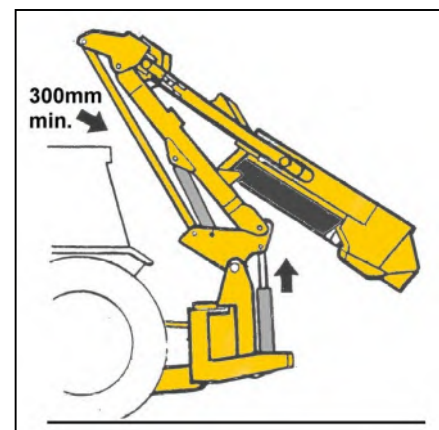

See following page for additional information regarding transport positions.

TRANSPORT POSITION FOR REAR MOUNTED MACHINES

The machine is transported inline to the rear of the tractor with a minimum of 300mm (12") clearance between the tension link and the rear cross member of the tractor cab.

Transport Position with Flailhead Attached

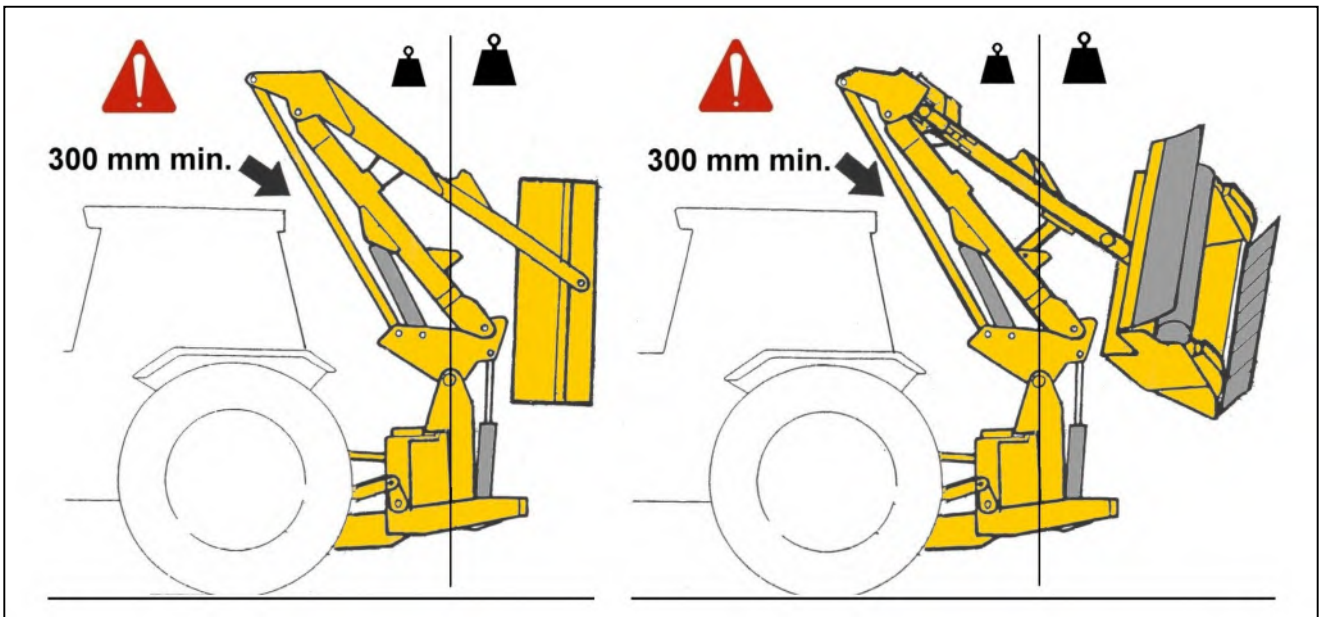

Transport Position with Flailhead Removed

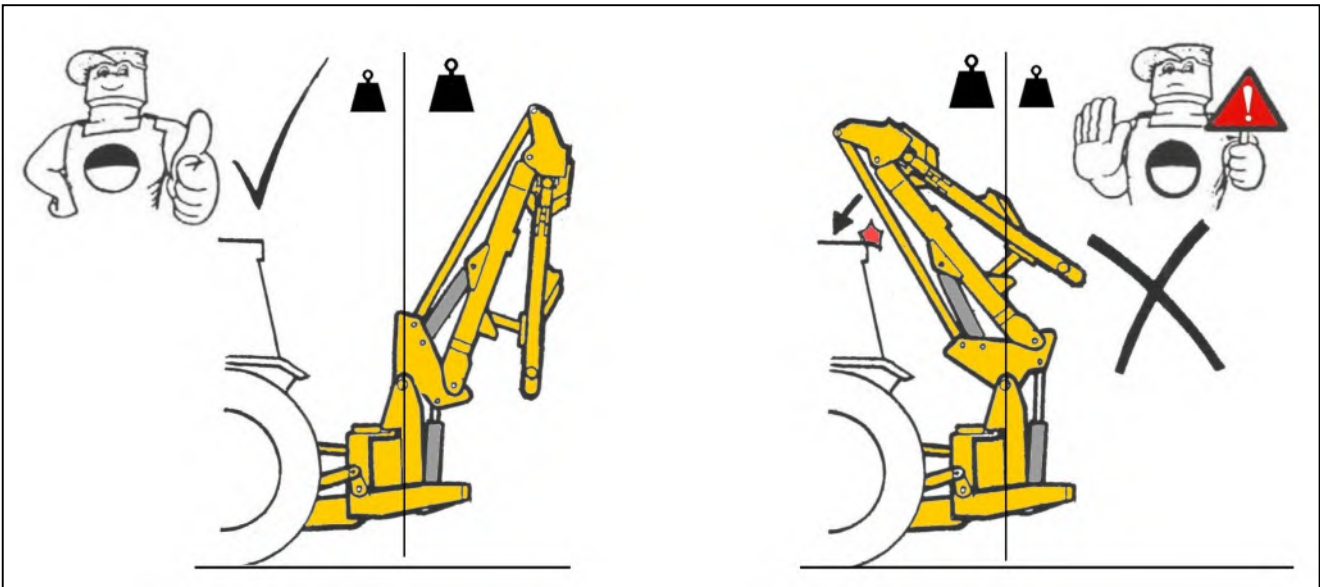

For transportation without a flailhead attached, the machines arms must be fully folded and the lift ram fully retracted so the mass of the arms is behind the centre line – *If the lift ram was extended the weight of the arms would be in front of the centre line which would result in the balance of the machine going 'over centre' causing the tension link to crash into the rear cross member of the tractor's cab.*

⚠ WARNING

During transport the 'SLEW' mode must ALWAYS be selected on the controls.

TRANSPORTING THE MACHINE

Transport Height

There is no fixed dimension for the transport height as this will vary for differing applications i.e. tractor size, carrying height, and degree of arm fold the particular tractor cab will permit.

For the majority of installations the transport height is within the region of approximately 4.1m to 4.4m.

It is advisable that once your machine has been installed on the tractor that it is folded into the transport position and your own measurement taken to ensure you have an accurate figure for the transport height.

⚠ CAUTION

Always be aware of the transport height of your machine and proceed with care when manoeuvring near building, bridges and all other overhead obstructions.

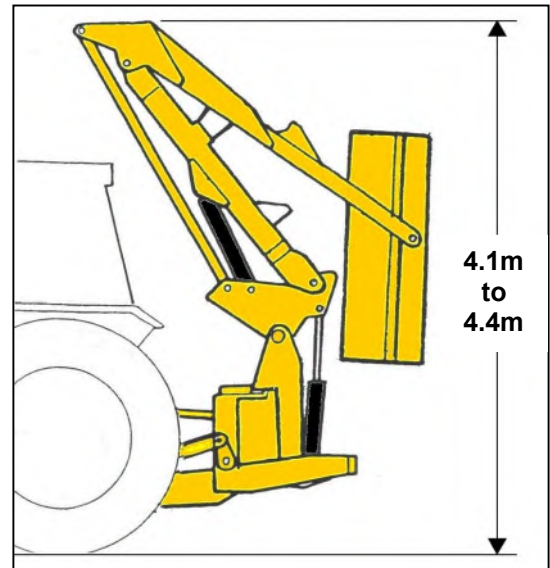

Approximate transport height

Transport Speed

The acceptable speed of transport will vary greatly depending upon the ground conditions. In any conditions avoid driving at a speed which causes exaggerated bouncing as this will put unnecessary strain on the tractors top hitch position and increase the likelihood of the tension link coming into contact with the cab rear cross member.

⚠ WARNING

During transportation of the machine the PTO must be disengaged and power to the controls switched off.

⚠ CAUTION

On machines equipped with multi-hole type stabilizers it is vital that the stabilizer position pin is always removed for machine transport and only fitted for work; failure to observe this can result in serious damage to machine and/or tractor components.

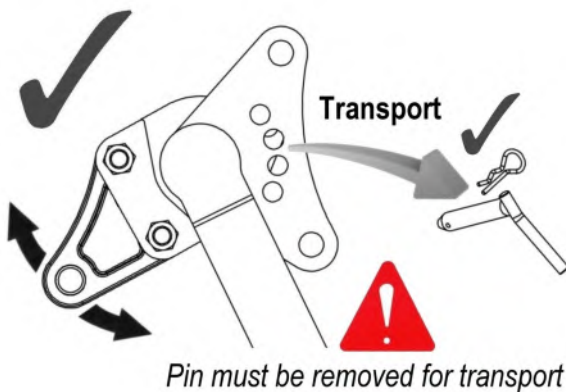

Pin must be removed for transport

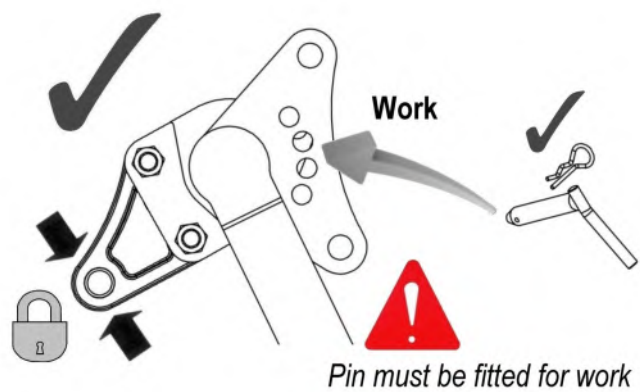

Pin must be fitted for work

MOVING FROM TRANSPORT TO WORK

Reverting to the work position is basically a reversal of the previous work to transport procedure.

NOTICE

Always remember to release the slew and lift locking devices before attempting to move the machine from the transport position.

Engaging Drive

Ensure the rotor control lever/switch is in the 'stop' position before engaging the PTO shaft. Allow the oil to circulate for a minute or so before operating the armhead levers. Position the flailhead in a safe position, increase the engine speed to a high idle and move the rotor control lever/switch to 'start' – after initial 'surging' the rotor will run at an even speed.

CAB PROTECTION SYSTEM (Early Models)

The machine features an inbuilt cab protection system to safeguard the rear crossmember of the tractor cab from possible damage caused by the arms coming into contact with it during transportation or when the arms are being manoeuvred directly behind the tractor.

The system consists of a shoe stop attached to the machine's pillar and connected to the main frame by an adjustable link; the geometry of the system causes the stop to progressively rise into position behind the rocker as the arms are slewed rearwards.

On initial installation of the machine the link must be adjusted to set the stop at the correct height for the particular application – once set it will not require any further adjustment unless the machine is removed and used on another tractor.

In transport position the rocker must be clear of the cab protection stop by 5mm minimum - NOT IN CONTACT.

Clearance Warning Decal ►



CAUTION

When operating the slew function with the machine positioned to the rear of the tractor ensure the rocker remain sufficiently clear of the stop at all times. When placing the machine into the transport position the arms should be directly in line with the tractor before finally operating 'lift up' and/or 'reach in' to position the rocker just clear of the stop - ***the gap should be a minimum of 5mm.***

In the same manner when moving out of transport 'lift down' and/or 'reach out' should be the initial operation to move the rocker clear of the stop before operation of slew.

Ensure rocker is moved clear of cab protection stop before slewing the arms ►



CAB PROTECTION SYSTEM (Current Models)

The cab protection system safeguards the rear crossmember of the tractor cab from possible damage caused by the arms coming into contact with it during transportation or when the arms are being manoeuvred directly behind the tractor.

The system consists of a 'shoe stop' bracket attached to the machine's rocker and an adjustable strut and socket that bolts to the main frame of the machine.

On initial installation the strut must be adjusted to set it at the correct stop height for the particular application – once set it will not require any further adjustment unless the machine is removed and used on another tractor.

In transport position the rocker must be clear of the cab protection stop by 5mm minimum - NOT IN CONTACT.

Clearance Warning Decal ►



⚠ CAUTION

When operating the slew function ensure the rocker remains sufficiently clear of the strut at all times.

When placing the machine into its transport position the slew function should be operated, ensuring the rocker stop is clear of the strut, until the pillar is into its transport position and the slew locking pin can be installed. The arms can then be fully 'reached in' until the dipper arm rests on the transport prop on the main arm and the final operation of 'lift up' carried out.

When operating 'lift up', bring the shoe on the rocker to a position where it is just clear of the strut, do not bring them into contact, - ***the gap should be a minimum of 5mm.***

In the same manner when moving out of transport operate the 'lift down' function first before slewing to ensure that the rocker shoe and the strut are clear of one another.

⚠ CAUTION

Ensure rocker shoe is moved clear of the adjustable strut before slewing the arms.

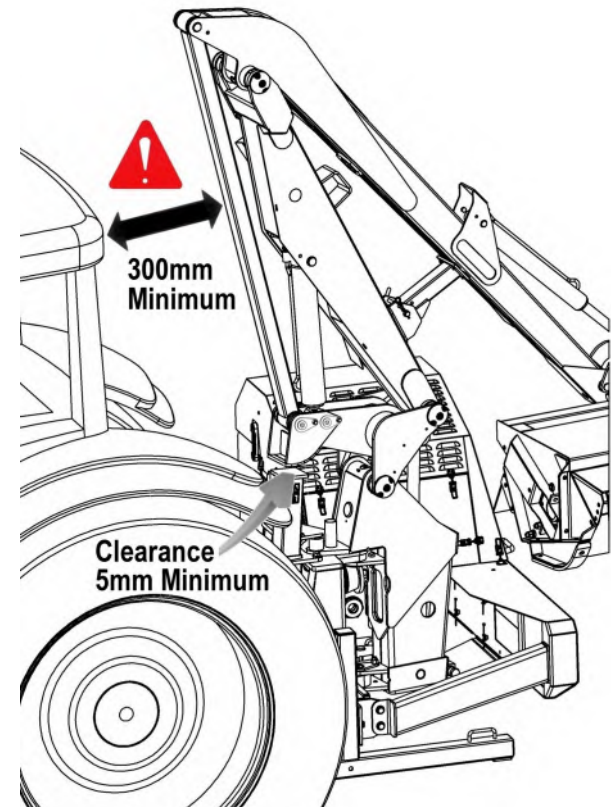
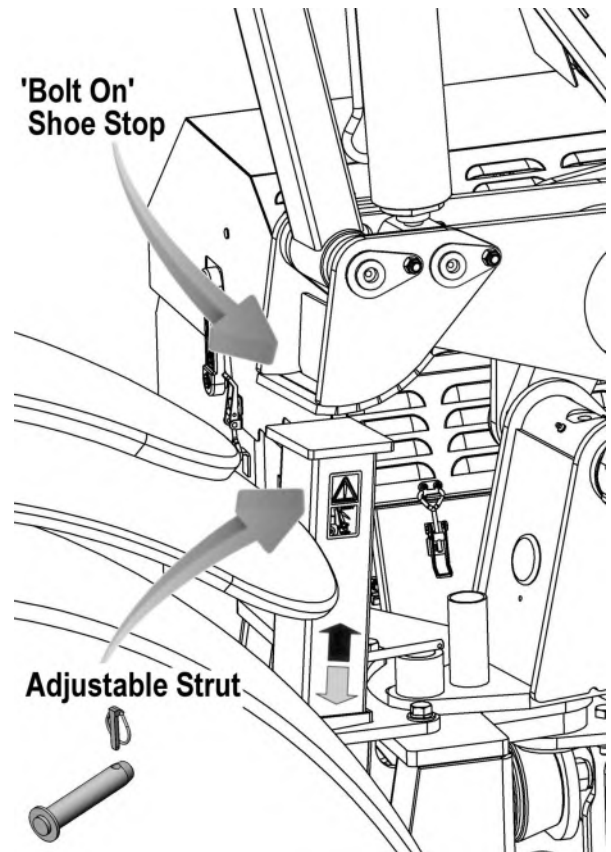

BREAKAWAY

The machine is fitted with a hydraulic breakaway device which protects the structure of the machine should an unforeseen obstacle be encountered.

NOTICE

The breakaway function does not relieve the operator of his responsibility to drive carefully – always be alert and avoid obvious hazards before contact occurs.

Breakaway may occur momentarily during normal work should an extra thick or dense patch of vegetation be encountered. In these instances tractor forward motion may be maintained with care.

Where breakaway has occurred as a result of contacting a post or tree etc. the tractor must be halted and the controls of the machine utilised to manoeuvre the head away from the obstacle. **Never continue forward motion to drag the head around the obstacle in breakback position.**

NOTICE

The force required to activate the breakaway system will vary dependent upon the gradient of work – It will require less force when working uphill and vice versa.

On mid-cut machines the geometry of the breakaway will cause the head to initially move outwards in addition to rearwards; therefore, be aware that the breakaway action will be impeded if the outer end of the head is working against a steep bank - in this circumstance extra care must be taken during operation to avoid this occurrence.

Breakaway occurs at the slew column pivot. When an obstacle is encountered continued forward motion causes the pressure in the slew ram base to rise until the relief valve setting is exceeded.

With 'Auto Reset' selected

When the slew relief valve setting is exceeded oil is displaced from the slew ram into the base of the lift ram which causes the head to rise as the arm pivots backwards to clear the obstruction.

Resetting of the head into the work position occurs automatically.

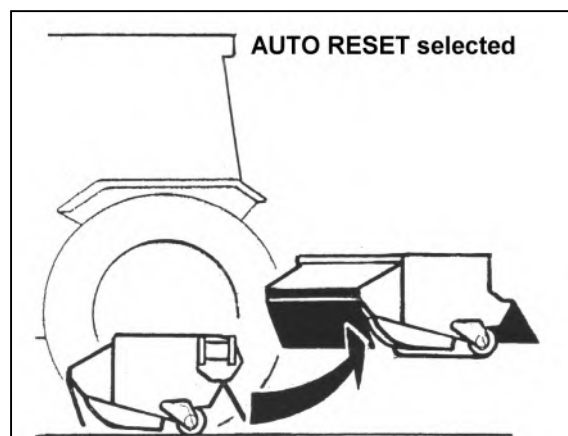

With 'Slew' selected

When the slew relief valve setting is exceeded oil is displaced from the slew ram allowing the arm to pivot backwards horizontally and the obstacle to be cleared.

Re-setting the head into the work position is carried out manually by selecting 'slew out' on the control assembly

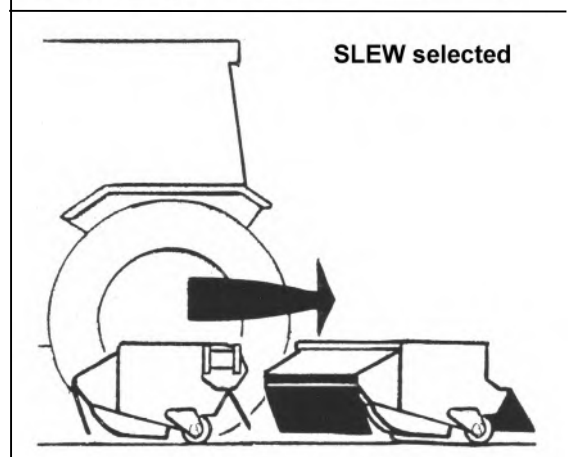

POWERED SLEW

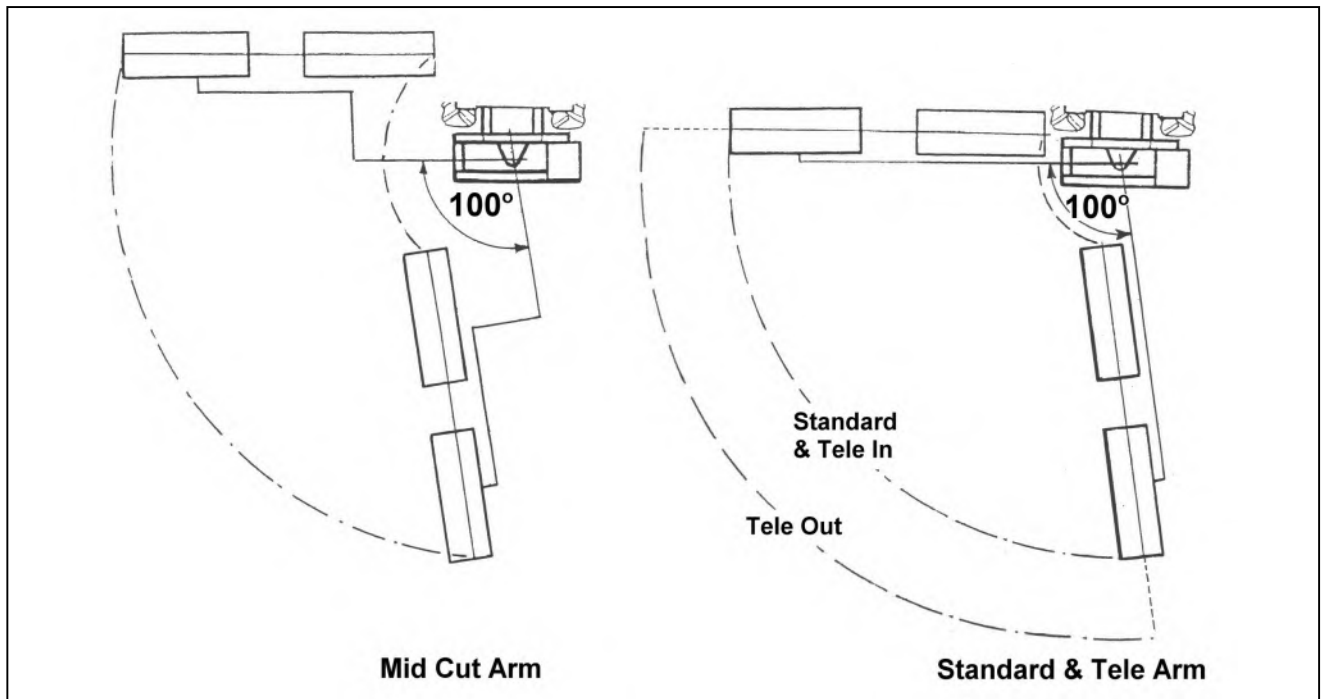

The slew feature allows a 100° arc of powered arm movement on the working side of the tractor; from the position at right angles to the tractor rearwards to 10° beyond the direct line astern - this feature is required to place the machine in the transport position but can also be used to sweep the arm 'to and fro' whilst cutting awkward areas and corners thus avoiding the need to constantly re-position the tractor. To operate in this way 'slew' must be selected on the control assembly.

CAUTION If breakaway occurs, the slew motion must be reversed to allow the slew breakaway relief valve to re-seat and the ram to become operable again.

CAUTION

Extra care must be taken when working in 'SLEW' mode with 'reach fully in' as it is possible for the flail head to come into contact the tractor or machine frame

PARALLEL ARM GEOMETRY

This feature enables the operator to adjust the 'in and out' reach of the machines arms, without the need to continuously adjust the 'lift' service in order to compensate for the change in head pivot height - as would be the case with conventional arm geometry.

NOTICE

The performance of this feature is at its most accurate during the mid-range of the reach travel, with some deterioration in performance being experienced when the outer extremities of reach adjustment are approached.

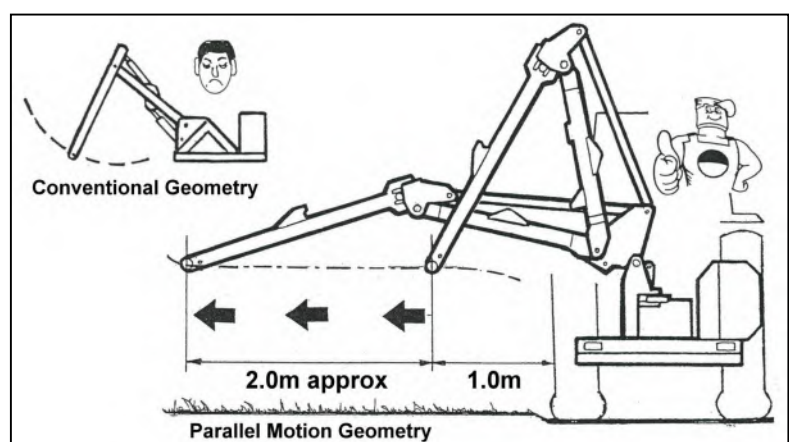

VFR ARMS – OPERATING CAUTION

The advanced manoeuvrability that VFR armsets offer permits cutting attachments to be positioned extremely close to the rear and working side of the tractor; this increases the opportunity of tractor and machine to suffer accidental damage from each other. Apply extreme caution whilst operating the armset close to the tractor and keep at a safe distance.

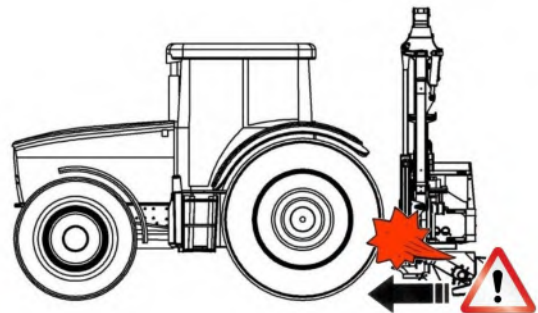
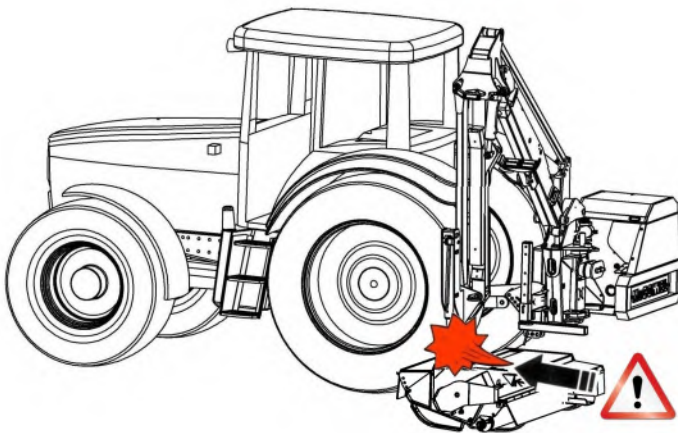
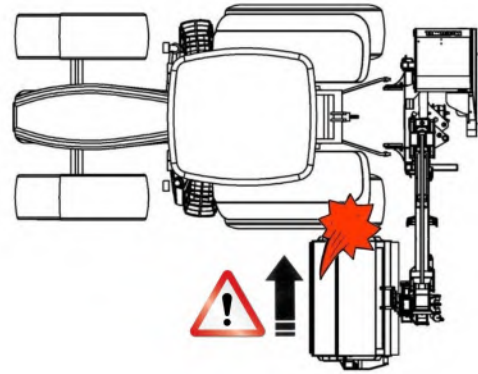
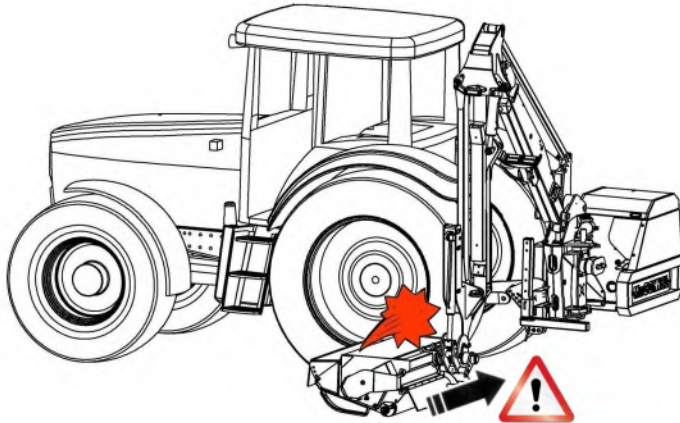

CAUTION

Ensure the head attachment and armset remain at a safe distance from the tractor during operation. Damage can occur if the machine and tractor come into contact.

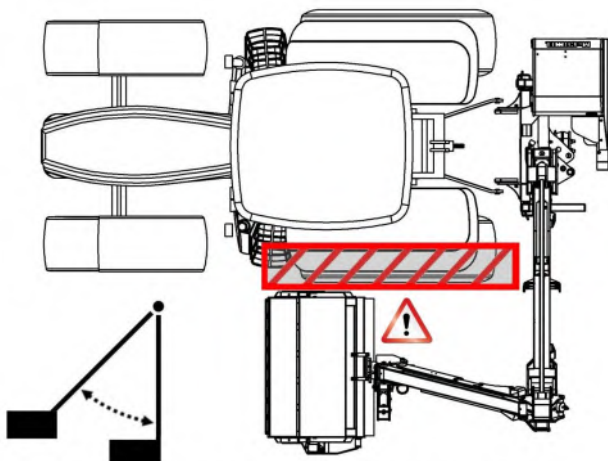

FORWARD POSITION - CONTACT RISK ZONE

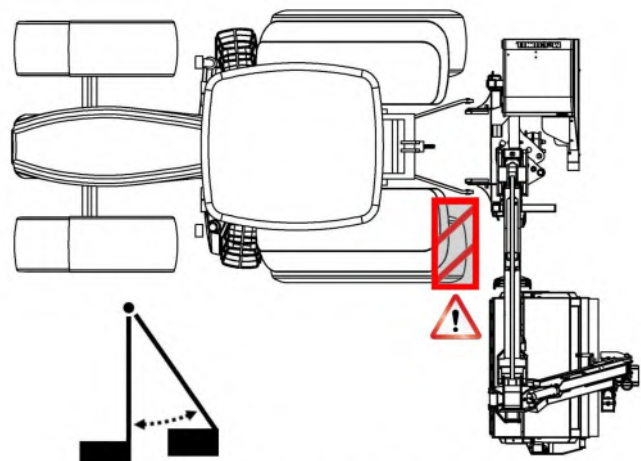

REARWARD POSITION - CONTACT RISK ZONE

EASY DRIVE SYSTEM (EDS)

The Easy Drive System (EDS) is an optional extra on larger proportional machines with V4 or Revolution digital controls – where fitted it provides ‘hands free’ cruise control operation with automatic head and lift float at greater working speed that increase both safety and efficiency.

The system comprises of sensors that measure rotational movement of the rocker pin and pressure variations in the lift ram circuit these are processed and forwarded to the hydraulic system which then regulates the optimum lift ram pressure to allow the arm and head to ‘float’ over changing ground contours. With readings taken and processed every 30 milliseconds the lift ram pressure is constantly and rapidly re-evaluated and adjusted.

Any movement of the joystick in the lift plane will automatically de-activate EDS, on release of the joystick the system will immediately be reverted back to EDS mode - *this is particularly useful feature for manoeuvring the machine around obstructions.*

The EDS system has 3 user settings available for differing operating conditions – these are soft, medium and hard. For machines where EDS is installed refer to the specific control information for details of operation.

ANGLE FLOAT KIT (Standard Feature)

Machines are fitted with Angle Float as standard – when activated the feature connects the base and gland circuits of the angle ram to allow free movement of oil in both directions thus allowing the head to automatically angle itself to match the contours of the ground.

Refer to specific controls section for details of operation.

NOTE: On machines with V4 or Revolution proportional controls any operation of the angle float thumbwheel will override and de-activate the automatic angle float function, on release of the thumbwheel it will revert back to automatic angle float.

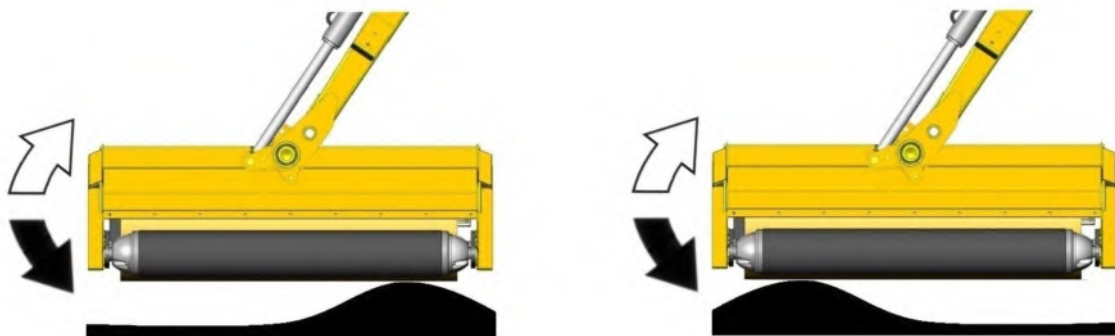

Angle Float Off – Requires operator input to adjust flail head angle

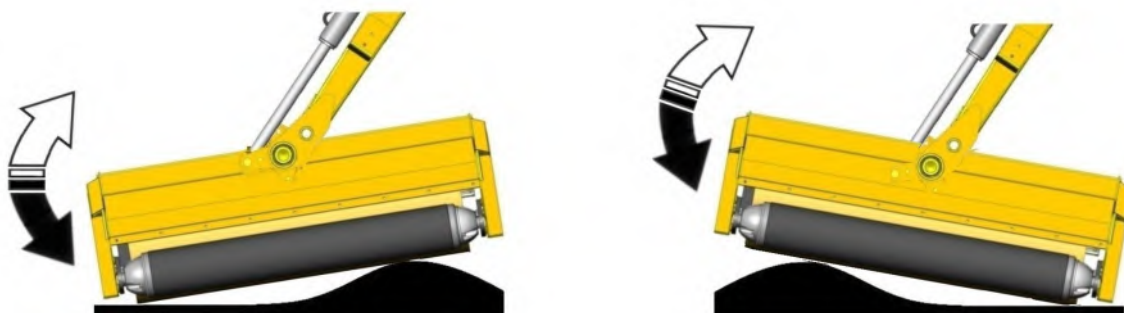

Angle Float On – Flail head automatically angles itself to match the ground contours.

LIFT FLOAT (Optional Extra for Ground Work)

Work without lift float requires far more concentration and input from the operator to quickly react and re-adjust to the ground contours often resulting in patches of higher cut material where the head is cutting too high and ‘scalping’ of the ground where it is cutting too low – *in the case of the latter this can lead to increased flail wear, damage or even loss of flails.*

The Lift float feature is an optional extra for use during mowing work. When the function is activated the pressurised accumulator(s) work in conjunction with the valve and lift ram to take a proportion of the flailheads weight off the flail roller allowing the head to automatically follow the natural contours of the ground; this produces a cleaner more uniform cut without the need for constant operator re-adjustment. On EDS models the function has 3 user settings for differing working conditions – these are soft, medium and hard. *Refer to the relevant control section for details of selecting the required setting.*

Operation of the lift float function is as follows: with lift float switched off, position the flailhead approximately 1m clear of the ground before switching the float function on to charge the accumulator(s) – *the arms may drop at this point depending on the current level of retained pressure.* Lower the flailhead into the work position, release the lift control and proceed to work. *NOTE: with the exception of EDS models, occasional operation of the lift function will be required when working on downhill or uphill slopes and when reaching in or out in order to replenish the oil level within the accumulator(s) to retain optimum float capability.*

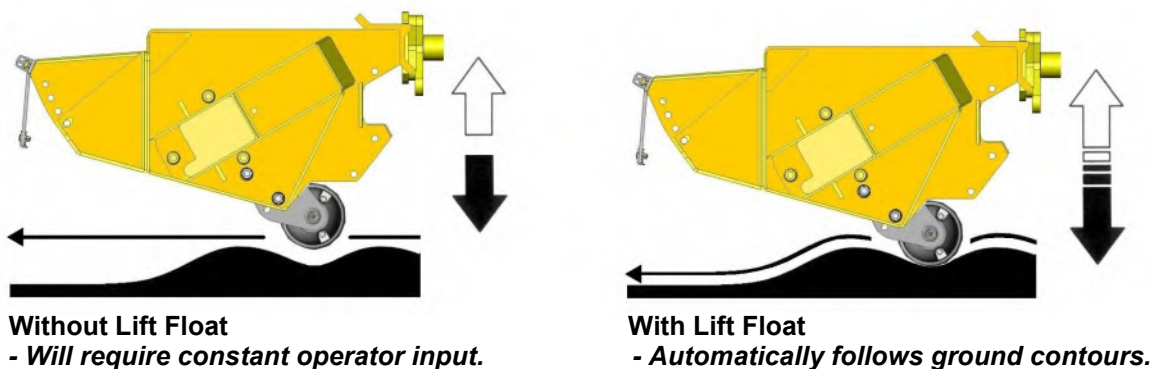

Lift float operation when supplied as a factory fitted option is controlled from the controls unit that accompanied the machine (*refer to controls section for details*), but the feature is also available for a range of models as an after market kit, in which case operation will either be via an auxiliary switch on cable controlled machines, or by utilisation of the auxiliary three-position type switch on the control unit of electric controlled machines - *this will allow for selection of ‘lift float alone’ or ‘lift and angle float in unison’ if both features are fitted.* Operation of the lift float control for these models will then be as specified in the main controls section.

Power Connection on Cable Machines

On cable controlled machines the switch supplied will need to be mounted in a convenient location in the cab. The supply cable from the poppet valve solenoid must be connected into the tractors ignition system - the brown lead is positive and the blue lead is negative.

Power Connection on Electric Machines

On electric controlled machines power to the unit is via the following connections:

Machines with 14 core looms use connection 10 and common connection 11.

Machines with 19 core looms use connection 15 and common connection 16.

V4 Non-EDS proportional machines use connections LF and C.

An after market Lift Float Kit (*Part No. 8126351*) is available for non EDS machines – *refer to the following page for details of mounting location and connections.*

LIFT FLOAT KIT for non EDS machines (Part No. 8126351)

The after market lift float kit is mounted to the inner side of the tank as shown in the illustration below left, a mounting plate with threaded holes is provided on the tank for this purpose. Hose and electrical connections are indicated in the illustration below right.

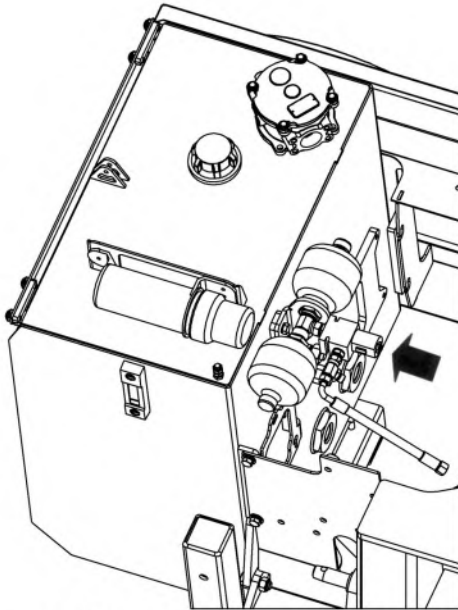

Lift Float Kit mounting location

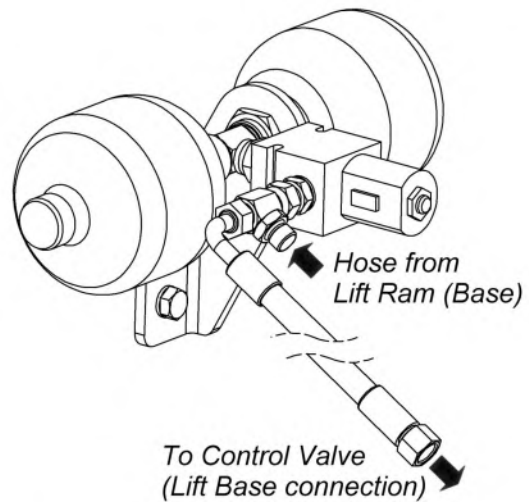

Connect wiring loom (Part No. 43177.28) to auxiliary box connections: LF (Red/White) & Common Negative (Black)

TELESCOPIC MACHINES (Tele)

Models PA6585T, PA7085T & PA8085T are equipped with telescopic dipper arms giving them additional reach capabilities. In normal working conditions the operator will pre-set tele to the desired position and the machine operated using the controls in the normal manner. Tele function mode can be used as an alternative to reach but a slower response to the commands must be expected.

It should be noted that the tele position will alter the parallel motion geometry of the machine, on these models parallel motion geometry will work best at ground level when the tele arm is fully extended, and at a height of approximately 4 - 5 feet high (1.2m - 1.5m) when the tele arm is fully retracted.

PRE-WORK PREPARATION & PRECAUTIONS

IMPORTANT: Always read the book first before attempting to operate the machine – practise operating the machine, without the rotor running, in a safe open space until you are fully familiar with all controls and functions of the machine. Only begin using the machine for work when you are confident that you have mastered the controls and operation sufficient for safe use of the machine.

CAUTION Care must always be taken when working with the flailhead close in to avoid contact with the tractor.

Pre-work Machine Checks

Prior to use of the machine always check all bolts are tight and that the torque figures are correct for the specific locations indicated below:

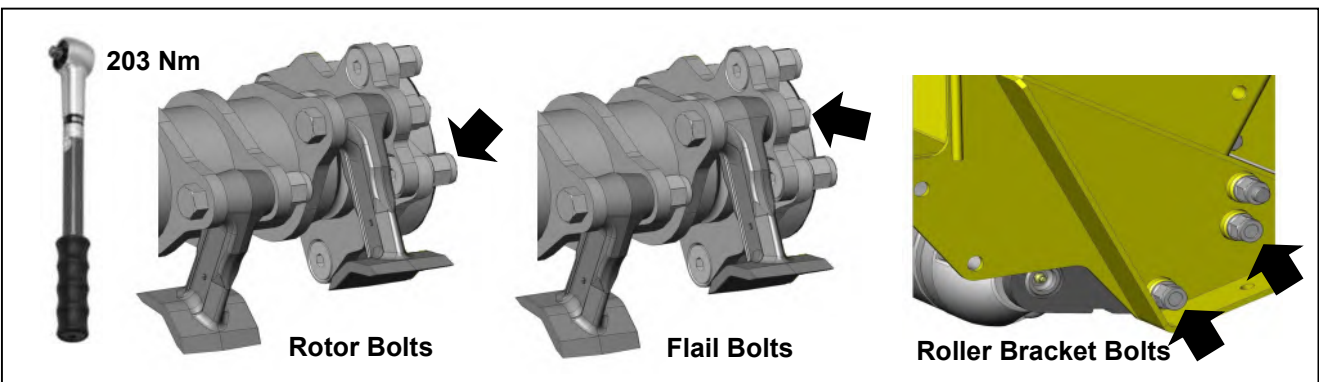
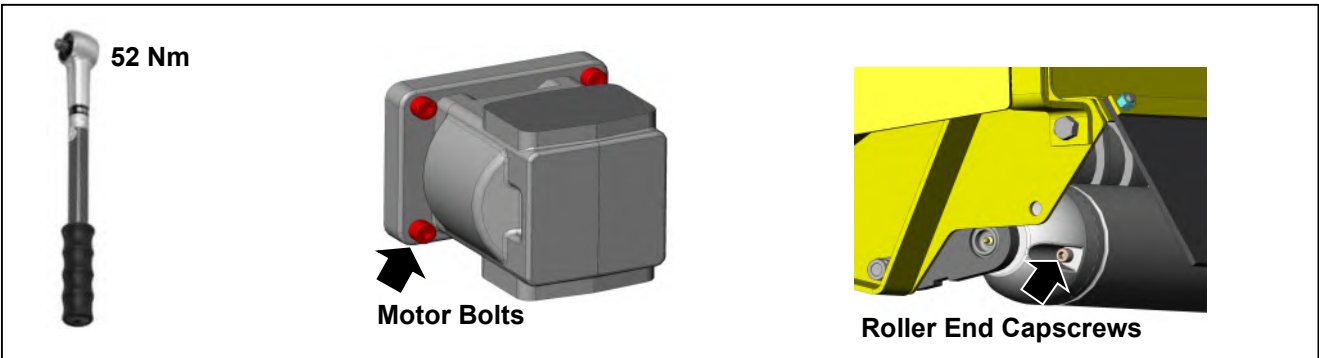

General Work Precautions

Inspect the work area prior to operation, remove any hazardous materials and note any immovable objects - *it may also be a wise precaution to mark these hazards with a visible marker than can be easily seen from the operating position in the tractor.*

If the type of work being undertaken makes this important precaution impractical, always maintain a high degree of alertness and restrict the tractors forward motion to a speed that allows sufficient time to stop the tractor or avoid the hazard before contact is made.

General Working Practice

It is the operator's responsibility to develop safe working procedures;

Always:

- ▲ Be aware of potential hazards in the vicinity of the work area.
- ▲ Ensure all guards are fitted correctly and in good condition.
- ▲ Disengage PTO before stopping the engine.
- ▲ Wait until the flail has stopped running before leaving the tractor seat.
- ▲ Disengage the PTO, stop the engine, remove and pocket the key before making any adjustments to the machine.
- ▲ Check frequently that all nuts and bolts are tight.
- ▲ Keep bystanders at a safe distance.

RUNNING UP PROCEDURE

⚠ CAUTION Before initial use of a new machine, all lubrication points must be greased and the gearbox and oil tank levels checked and where required topped up before attempting to use the machine. *Refer to maintenance section for details.*

The procedure for starting the machine is as follows:

- Ensure that the rotor control valve is in 'Stop' position.
- Start tractor and engage PTO - *allow the oil to circulate through the return line filter for about 5 minutes without operation of the armhead control lever.*
- Carefully operate the armhead controls through their complete range ensuring that all movements are functioning correctly.
- Place the flail head at a safe attitude and move the rotor control to 'Start' position, after initial fluctuation, the rotor should settle to a steady speed.
- Increase PTO speed to approximately 360RPM and run for a further five minutes before disengaging and stopping tractor.
- Check the hose runs and ensure that they are free from any pinching, chaffing, straining or kinks.
- Check the oil level in the tank and top up as necessary.

EMERGENCY STOPPING

In all emergency situations machine operation and functions must be stopped immediately; **Stop PTO operation** using the tractor controls then immediately kill electrical power to the machine using the **Off (Emergency Stop)** switch on the machine's control unit.

⚠ WARNING **Auto-Reset Machines**



When the Auto-Reset feature is active the machines arm set is capable of unintentional movement even when the PTO is switched off and stationary. Always ensure that electrical power to the machine is switched off using the **Off (Emergency Stop)** switch on the machine's control unit in emergency situations and/or when the machine is not being operated.

⚠ WARNING **Cable Operated Machines**



In certain conditions, and/or if the Auto-Reset feature is active, the arm sets on cable operated machines possess the potential to move unintentionally, even when the PTO is switched off and stationary, if the levers were to be accidentally operated. Care must be adopted to avoid any movement of the levers when the machine is not being operated. Ensure arm sets are lowered fully to the ground when the machine is parked up or not in use.

TELE VFR PURGE PROCEDURE

For correct VFR arm operation on Tele VFR machines, the inner and outer VFR rams must be synchronised to ensure the outer section of the VFR Arm and the Main Arm remain parallel with each other in all working positions.

In order to retain synchronisation of the VFR rams, it will occasionally be necessary to 'purge' air from the hydraulic system; the procedure for this is described below.

For Machines without 'purging' taps - Builds 09/19 ►

Operate the VFR function to place it in the 'fully rearward' position, continue operating VFR function in this position until the rams are correctly synchronised.

For Machines with 'purging' taps - Builds ► 08/19

On early machines, two ram taps are provided for performing synchronisation; these are located at the top of the arm adjacent to the inner VFR ram.

Synchronising the rams should be performed with the machine parked on a firm level site. The illustrations below show the location of relevant components on both left and right-handed machines and the purging procedure is shown on the following pages.

Location of VFR Rams & Taps (Builds ► 08/19 only)

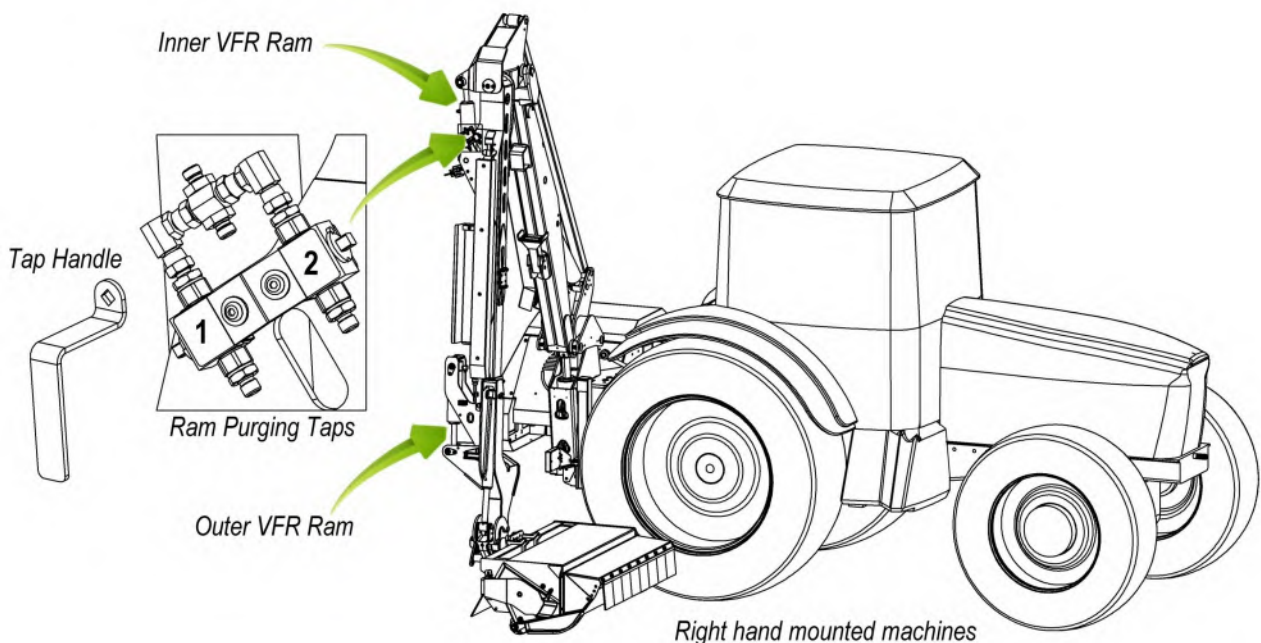
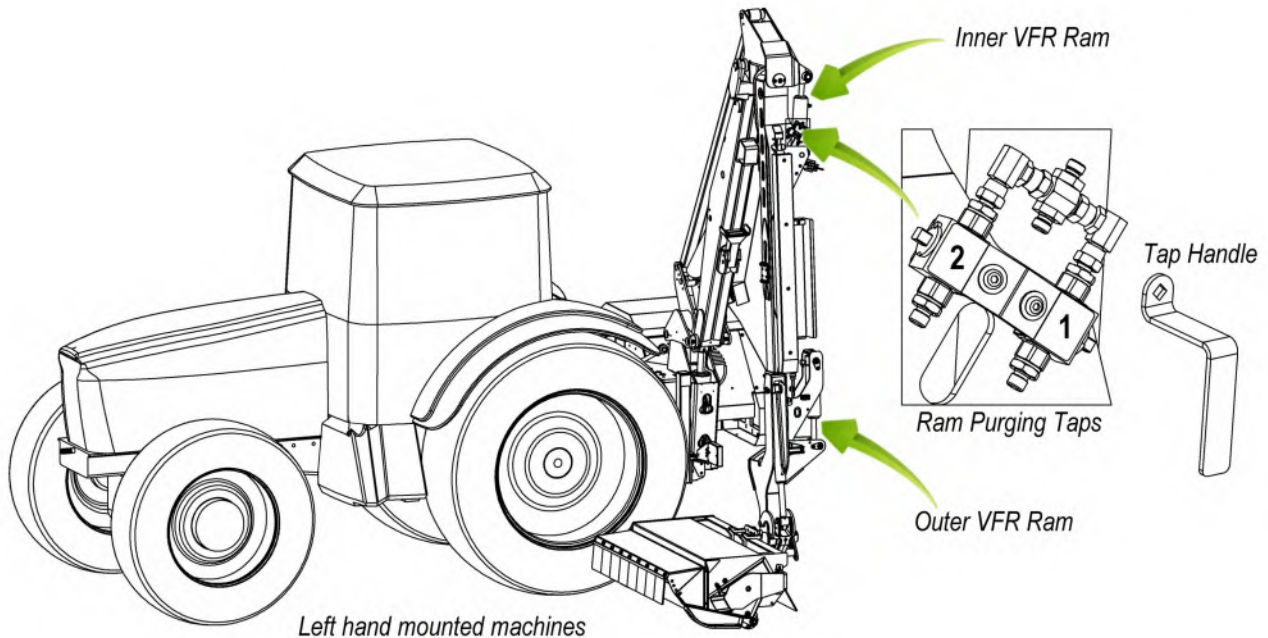

With the flail head on the ground, open both ram taps.

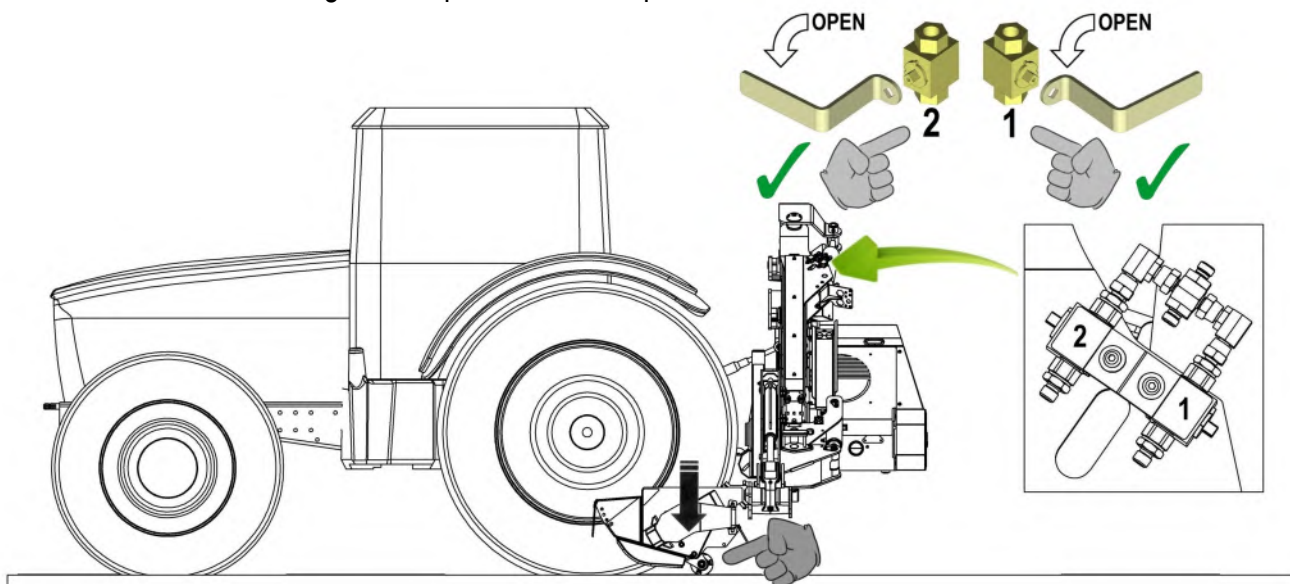

Using VFR function, move the arm into its fully forward position. Place flail head on ground ensuring the inner VFR ram is in its fully open position.

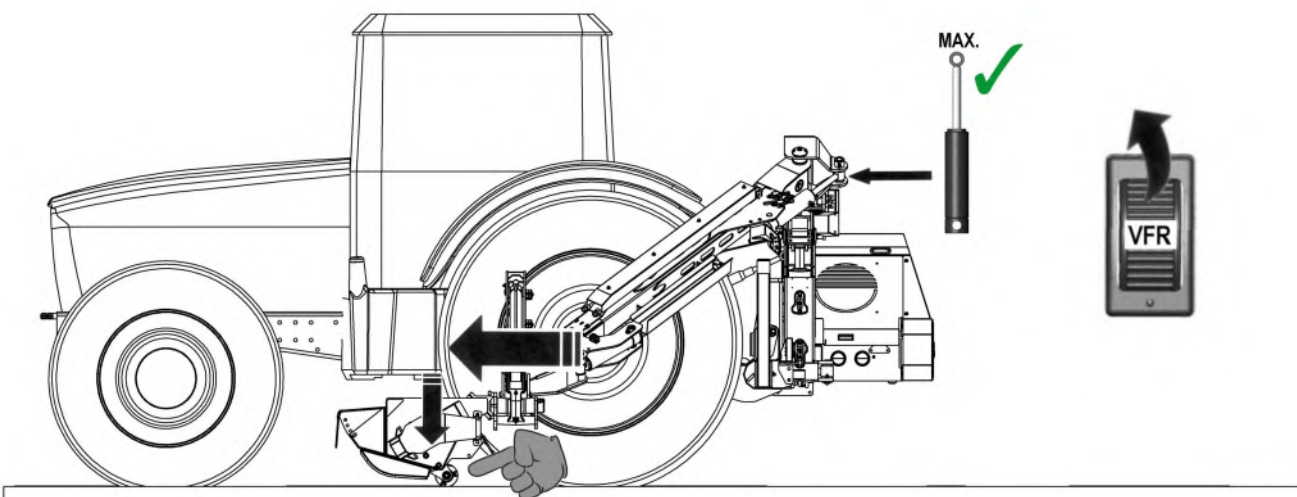

Operate the forward VFR function for 5 minutes to purge air out of the system.

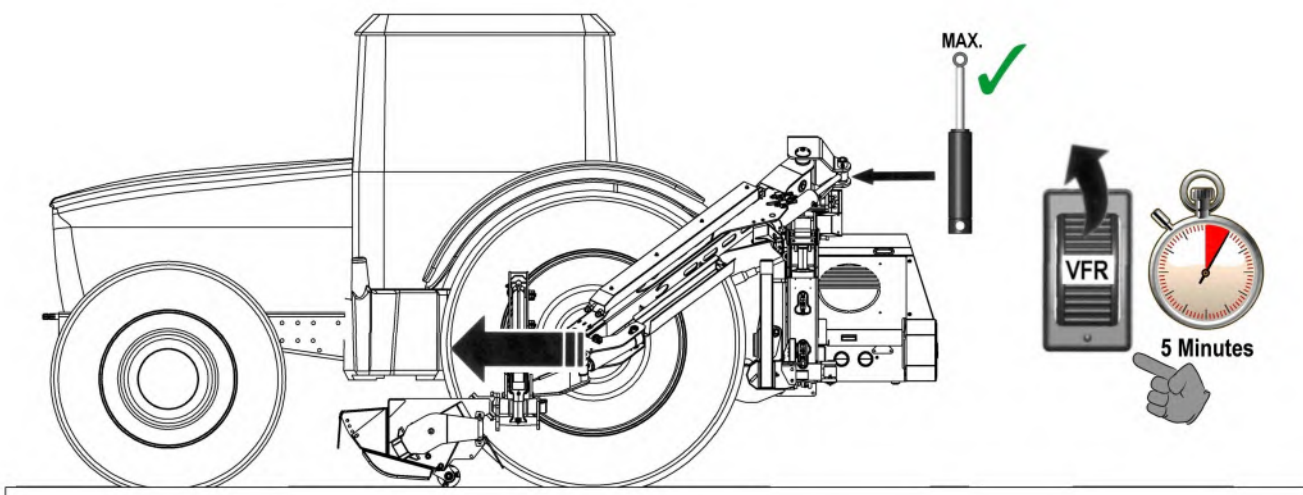

Close VFR ram tap #1

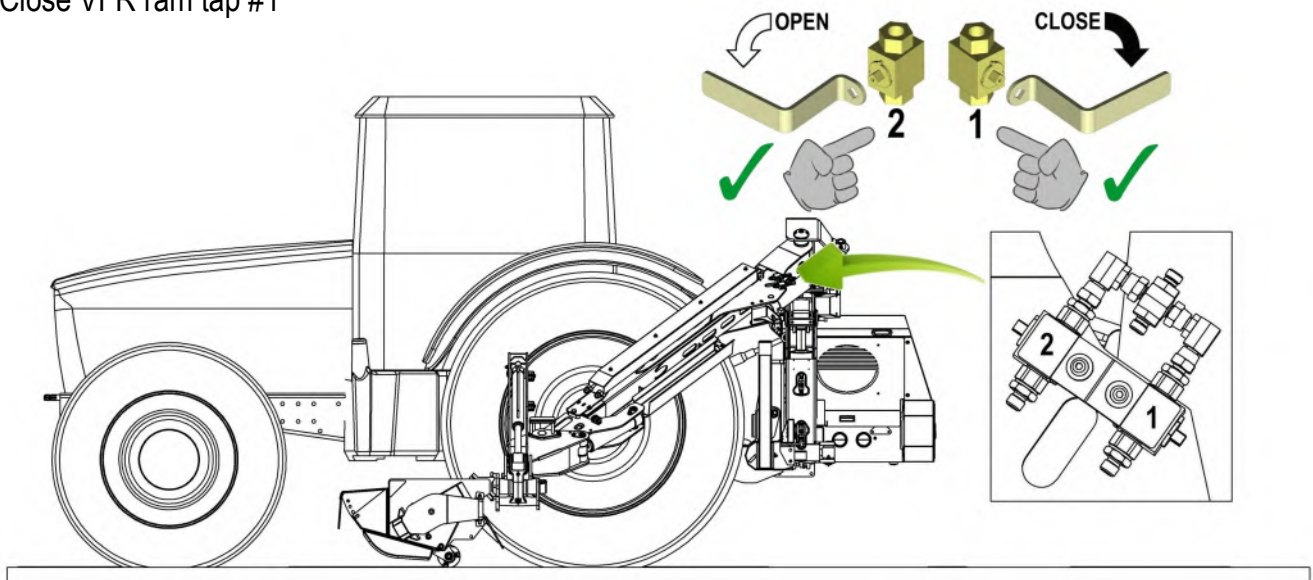

Using VFR function, move the arm into its fully rearward position. Place flail head on ground ensuring the inner VFR ram is in its fully closed position and the outer VFR ram is in its fully open position.

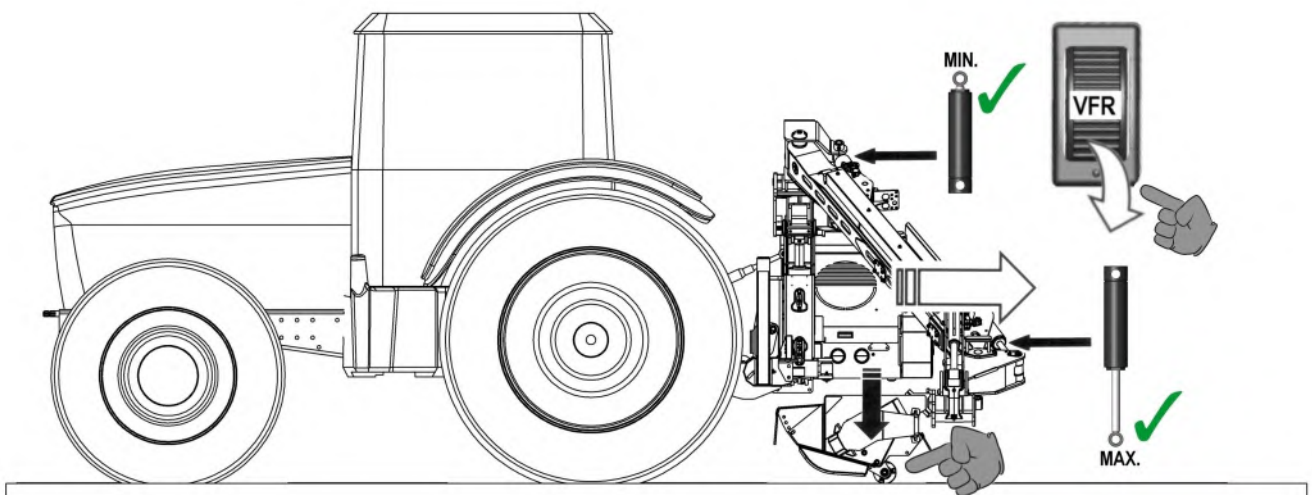

Operate the rearward VFR function for 5 minutes to purge air out of the system.

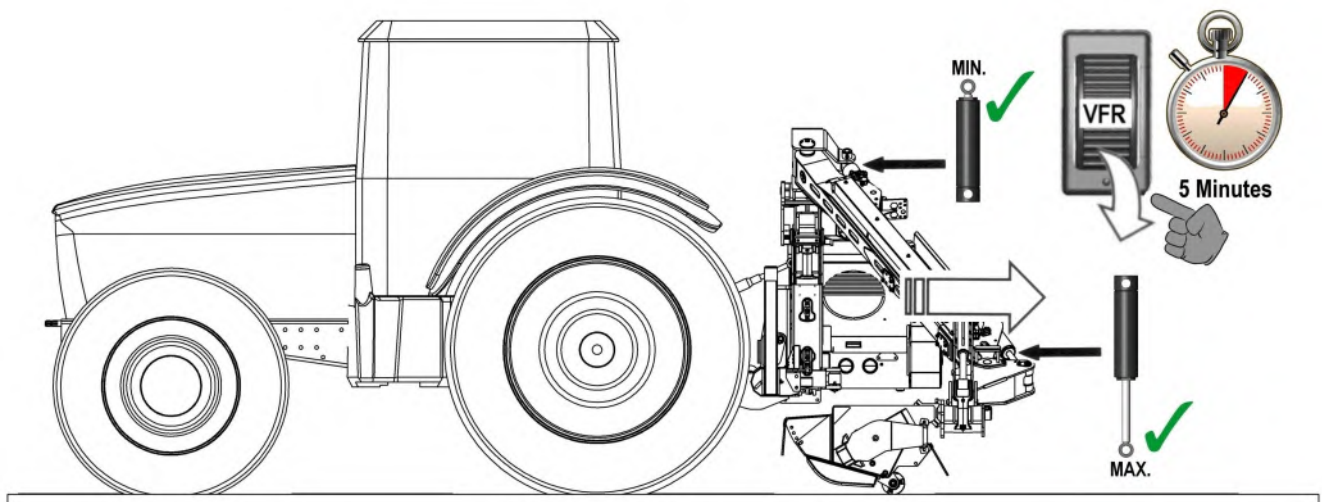

Close VFR ram tap #2

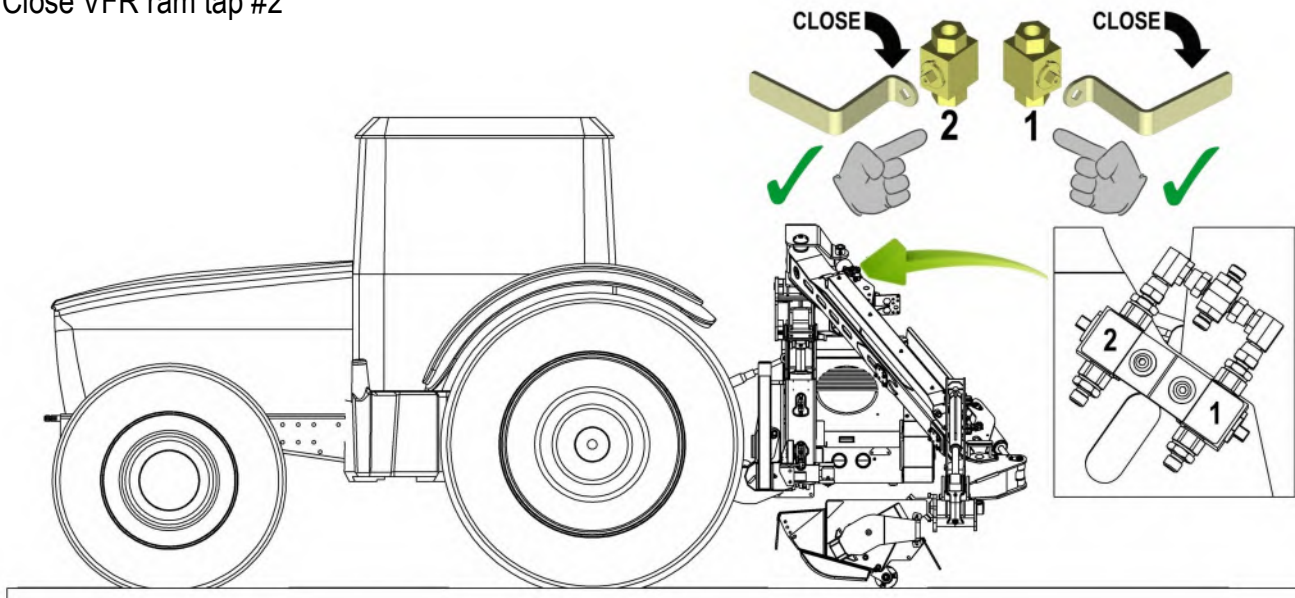

Operate VFR function to establish that rams are synchronised and that outer section of VFR arm and main arm remain parallel with each other in all working positions.

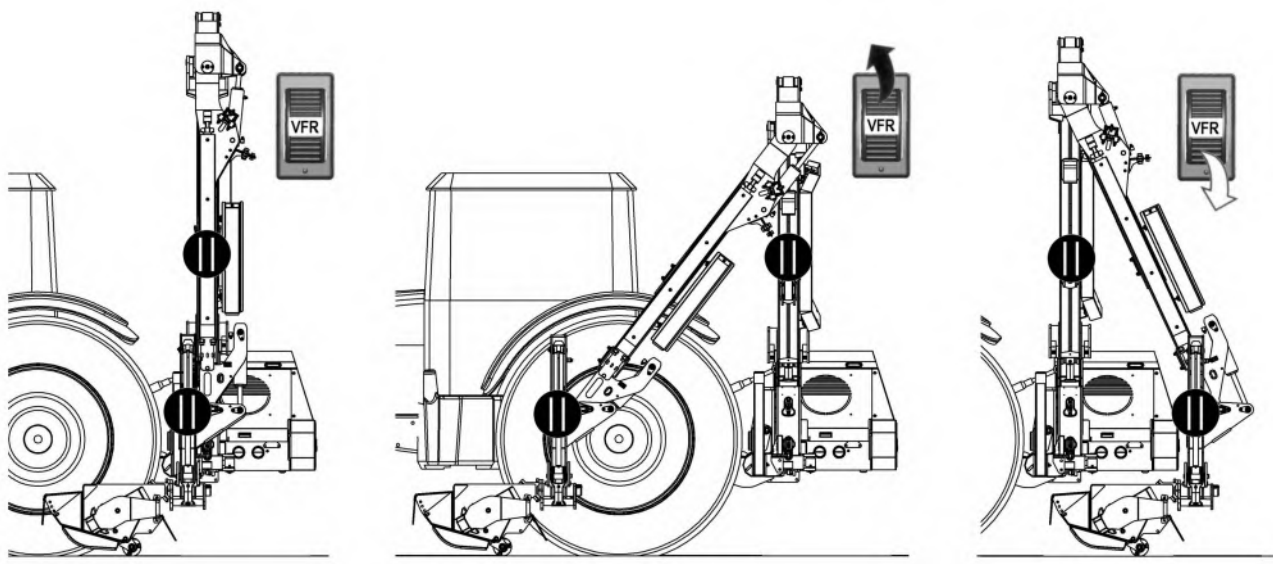

Hydraulic Installation

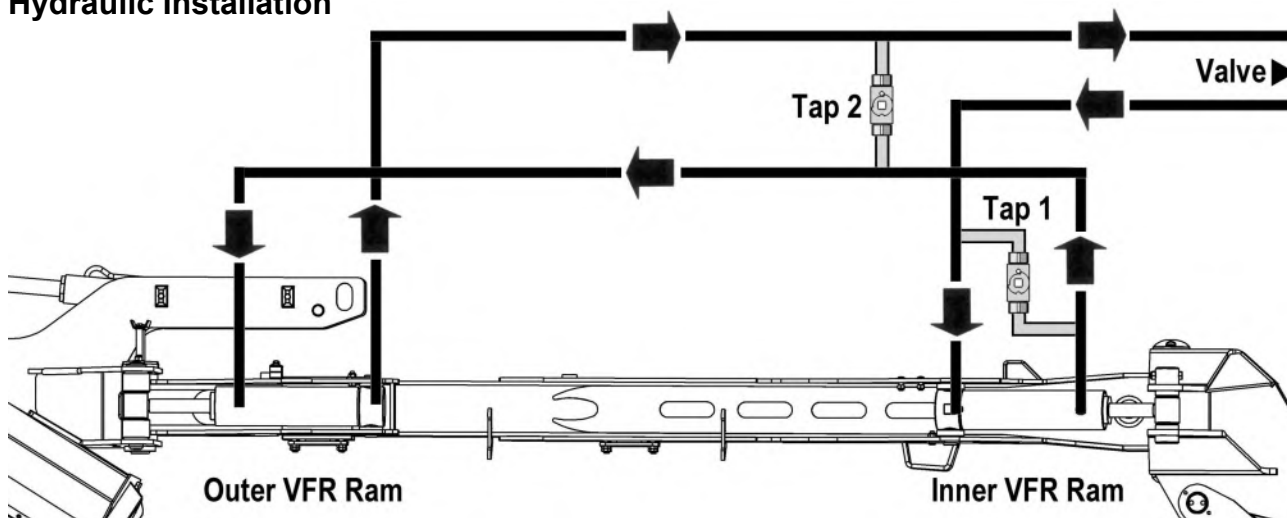

OPERATING SPEEDS









PTO Operating Speed

The correct PTO speeds for operation of machines is as follows:

IMPORTANT	Gear Models – Machines manufactured ► 11/16 : 500 – 540 RPM (Max)
	Gear Models – Machines manufactured 11/16 ► : 700 – 760 RPM (Max)
	Piston Models : 800 – 830 RPM (Max)



PTO DIRECTION & SPEED (MAX)

Gear Models <i>[Machines ► 11/16]</i>	Gear Models <i>[Machines 11/16 ►]</i>	Piston Models	
 500 - 540 RPM	 700 - 760 RPM	 800 - 830 RPM	
 540+ RPM	 760+ RPM	 830+ RPM	

Refer to the decal on your machine for specific details of PTO direction and maximum speed

CAUTION Damage to the machine may occur if maximum PTO speed is exceeded.

Engaging Drive

- Ensure the rotor control lever/switch is in the 'stop' position before engaging the PTO.
- Allow the oil to circulate for a minute or so before operating the armhead controls.
- Move the flail head into a safe working position just clear of the material to be cut.
- Increase engine speed to a high idle and start the rotor – *after initial 'surging' the rotor will run at an even speed.*
- Carefully lower the flail head into the work area and begin work.

Tractor Forward Speed

The material being cut will determine the tractor forward speed. Forward speed can be as fast as that which allows the flail head sufficient time to cut the vegetation both efficiently and neatly.

If forward speed is too fast this be indicated by over frequent operation of the breakaway system, a fall-off in tractor revs and a poor untidy finish to the work leaving ragged uncut tufts and poorly mulched cuttings.

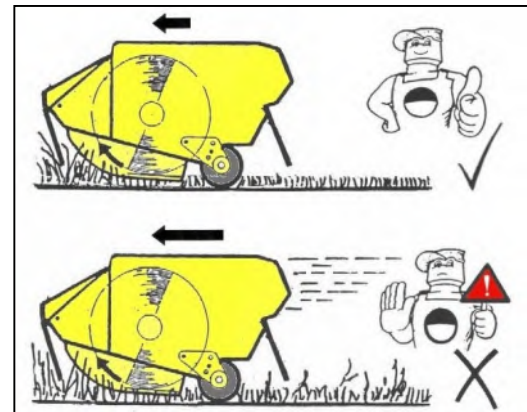

'Running In' a New Machine

For the first day's work with a new machine it is recommended that tractor forward speed is restricted to 3 km/hr (2 mph) maximum. This will allow machine components 'bed in' and allow the operator to become familiar with the controls and their response under working conditions whilst operating at a relatively slow speed. If possible, select a first day's work that affords mainly light to average cutting with occasional heavy duty work – *during this period check the tightness of nuts and bolts every hour, retightening as and when required.*

First day use - check tightness of nuts & bolts hourly ►

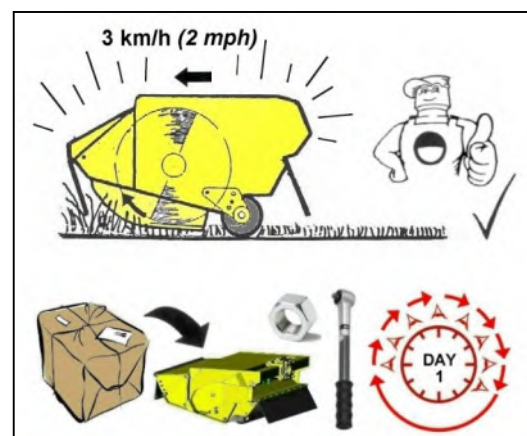

HAZARDS & DANGERS

Adverse Slopes

When working with the flailhead high and reach fully in it is possible for the main arm balance to go over centre and take the weight off the lift ram. A restrictor in the gland circuit of the lift ram will prevent sudden unpredictable movements if this should occur - *for reasons of safety this restrictor should not be removed.*

⚠ DANGER

NEVER REMOVE THE RESTRICTOR FROM THE LIFT RAM GLAND CIRCUIT.

Never work the machine on adverse slopes with the arms positioned such that the tractor is unbalanced ►

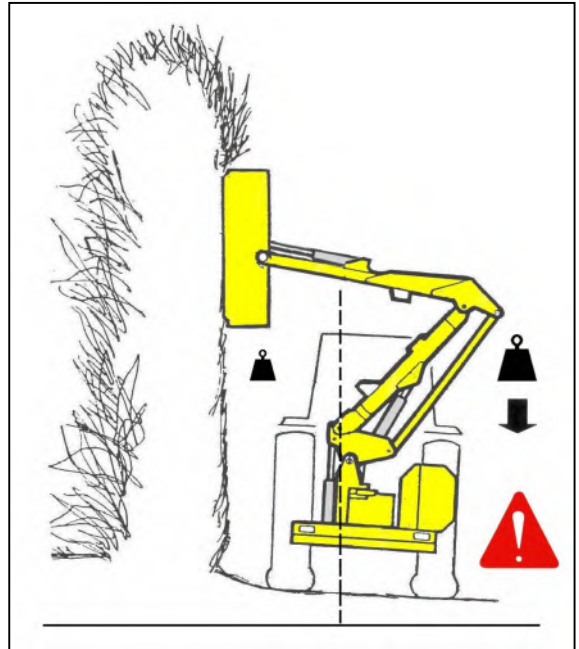

⚠ DANGER

NEVER CUT TO THE BLIND SIDE OF A HEDGE
- it is impossible to see any potential hazards or dangers and the position of the flail head would allow debris to be propelled through the hedge towards the tractor and operator.

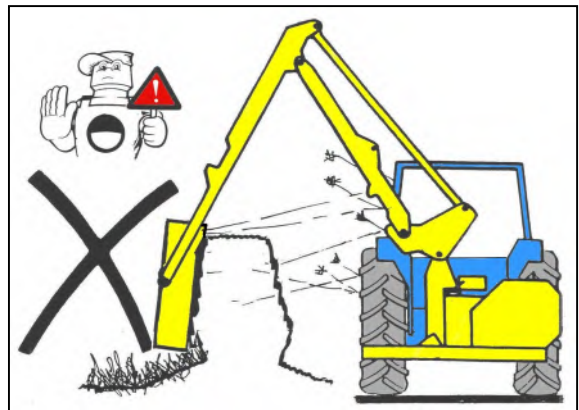

⚠ DANGER

NEVER OPERATE THE MACHINE WITH THE FLAIL HEAD ROLLER REMOVED

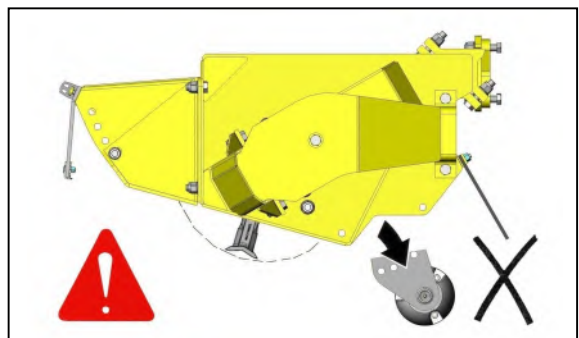

⚠ DANGER

WHEN GRASS MOWING THE ROTOR MUST ALWAYS CUT IN THE UPHILL DIRECTION WITH FRONT HOOD FITTED AND THE ROLLER POSITIONED BELOW THE CUTTING HEIGHT OF THE FLAILS

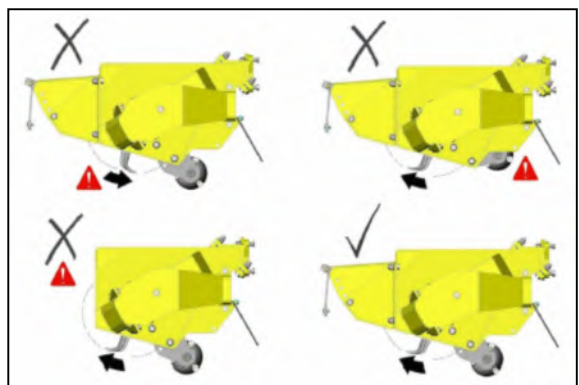

OVERHEAD POWER LINES (OHPLs)

It cannot be stressed enough the dangers involved when working in the vicinity of Overhead Power Lines (OHPLs). Some of our machines are capable of reach in excess of 8 metres (26'); they have the potential to well exceed, by possibly 3 metres (9' 9"), the lowest legal minimum height of 5.2 metres from the ground for 11,000 and 33,000 volt power lines.

Remember electrocution can occur without actually coming into contact with a power line as electricity can 'flashover' when machinery gets close to it.

⚠ WARNING All operators must read the following information and be aware of the risks and dangers involved when working in the vicinity of Overhead Power Lines (OHPLs).

Wherever possible the safest option is always to avoid working in areas close to OHPLs. Where unavoidable, all operators must perform a risk assessment and implement a safe procedure and system of work – see *following page for details*.

All operators should perform a risk assessment before operating the machine within 10m horizontal distance of any OHPLs.

Minimum Heights for Overhead Power Lines

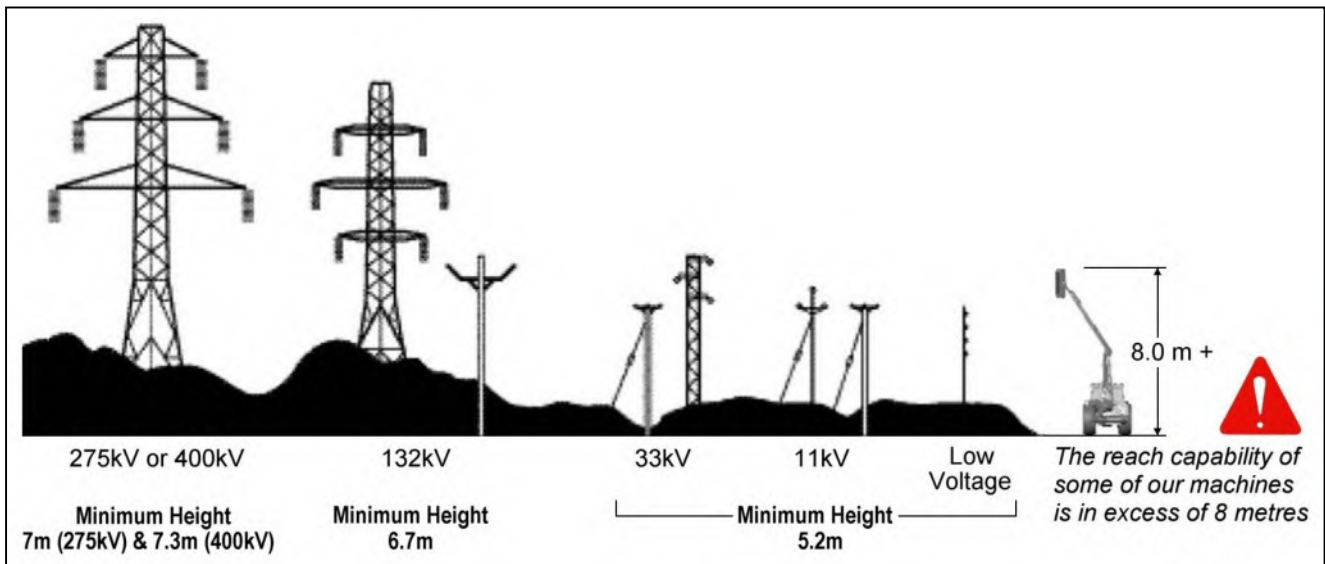

Absolute Minimum Exclusion Zones for Specific Overhead Power Lines

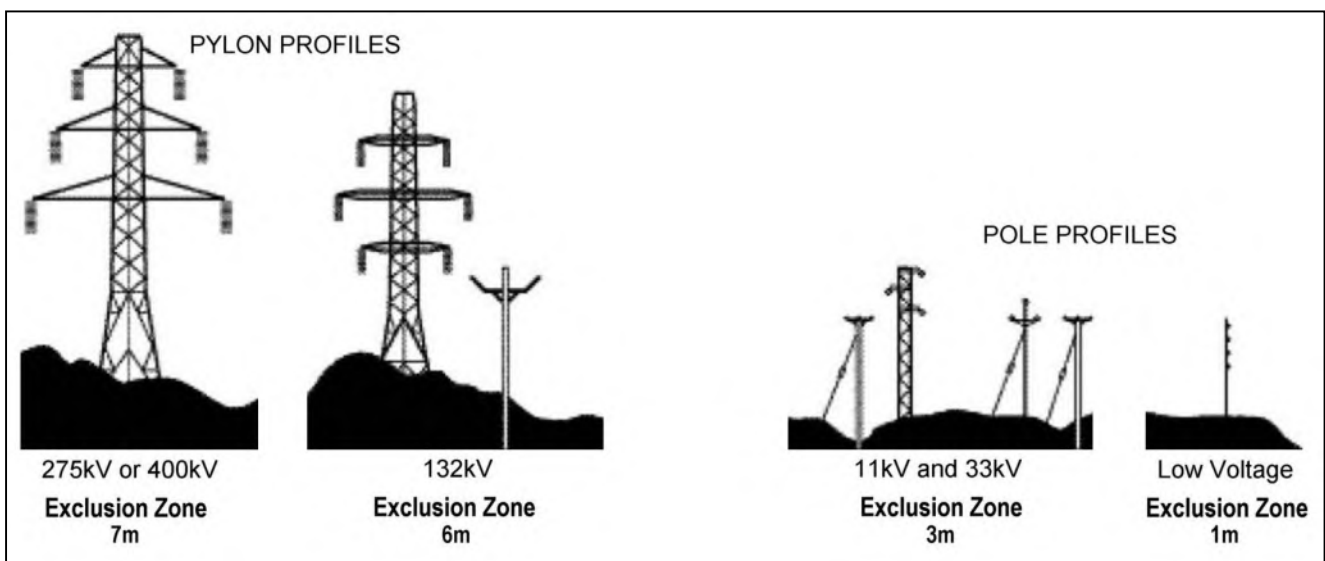

Definitions of Exclusion Zones

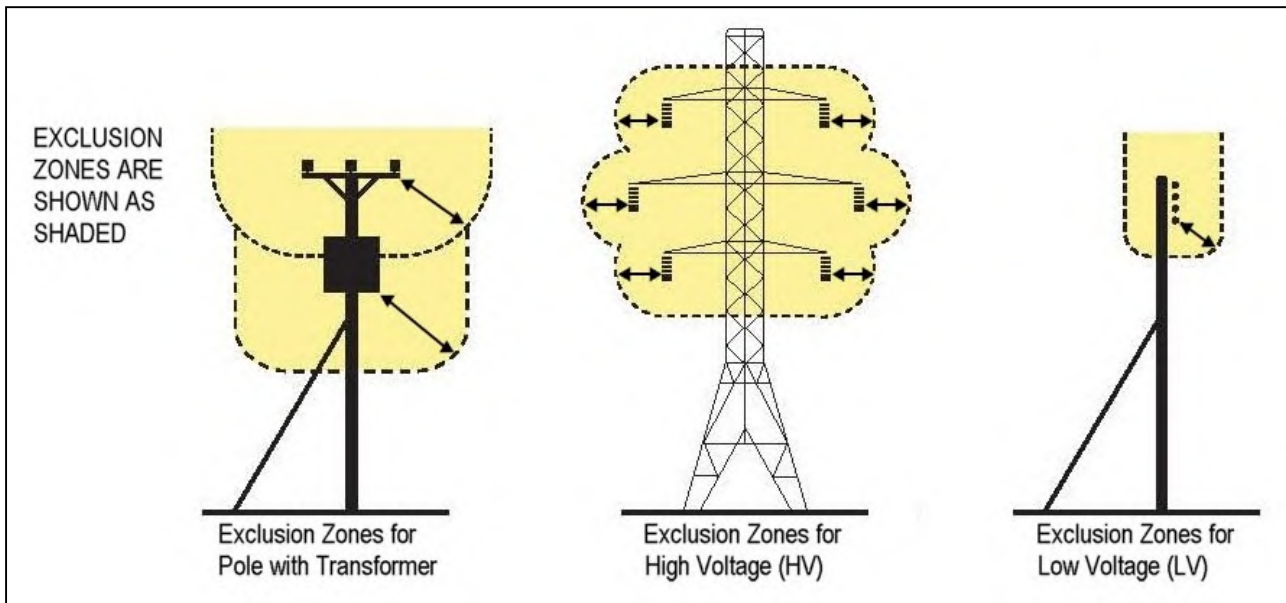

Risk Assessment

Before starting to work near OHPLs you should always assess the risks. The following points should be observed;

Know the risks of contacting OHPLs and the risk of flashover.

Find out the maximum height and maximum vertical reach of your machine.

Find out the location and route of all Power Lines within the work area.

Find out the operating voltage of all Power Lines within the work area.

Contact the local Distribution Network Operator (DNO) who will be able to advise you on the operating voltage, safe minimum clearance distance for working, and additional precautions required.

Never attempt to operate the machine in exclusion zones.

Always work with extreme caution and plan your work ahead to avoid high risk areas.

If doubt exists do not work in the area – never risk the safety of yourself or others.

Emergency Action for Accidents Involving Electricity

- Never touch an overhead line - even if it has been brought down by machinery, or has fallen. Never assume lines are dead.
- When a machine is in contact with an overhead line, electrocution is possible if anyone touches both the machine and the ground. Stay in the machine and lower any raised parts in contact or drive the machine out of the lines if you can.
- If you need to get out to summon help or because of fire, jump out as far as you can without touching any wires or the machine - keep upright and away.
- Get the electricity company to disconnect the supply. Even if the line appears dead, do not touch it - automatic switching may reconnect the power.

Further information and leaflets on this and other agricultural safety subjects are available on the 'Health & Safety Executive' website at the following address: www.hse.gov.uk/pubns/agindex.htm

HEDGECUTTING PROCEDURE

Cut the side and bottom of the field side first. This leaves the maximum thickness of hedge on the road side to prevent the possibility of any debris being thrown through the hedge into the path of oncoming vehicles.

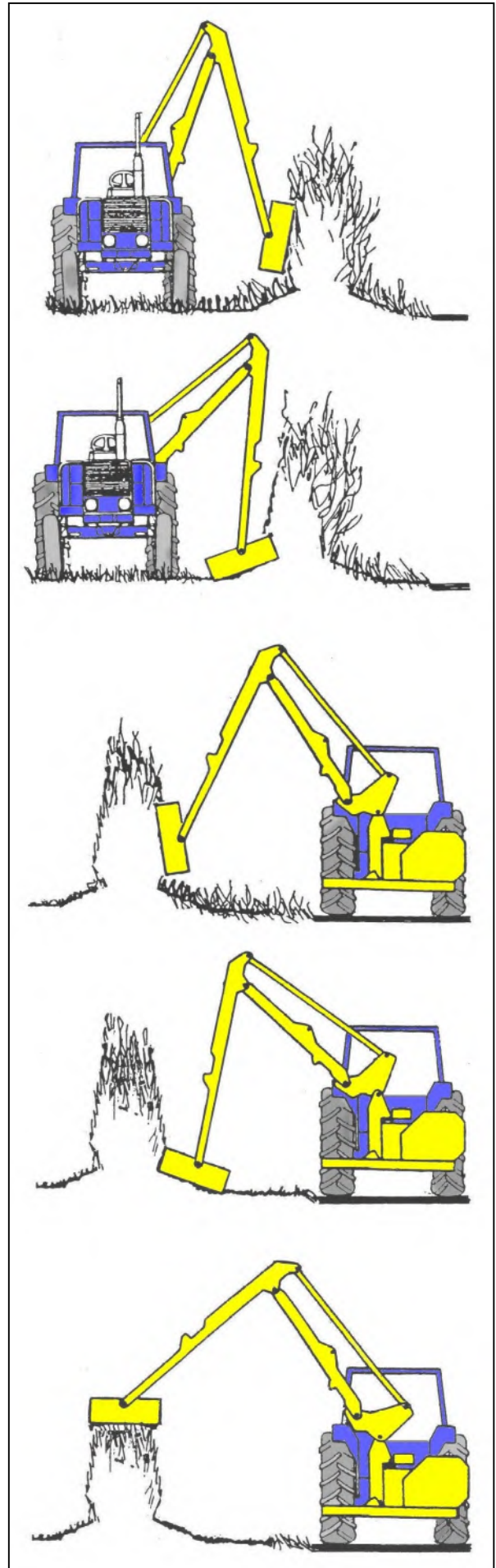

Cut the side and bottom of the road side.

Top cut the hedge to the height required.

FLAIL TYPES

Grass Flails

Designed specifically for general mowing activities – low power usage, ideal for cutting materials of low density.

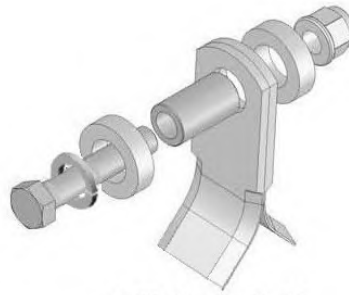

F10 Grass Flail
(Part No. 7190315)

Universal Boot Flails

Designed for general purpose work - suitable for mowing duties and the cutting of hedges with up to 2 years growth.

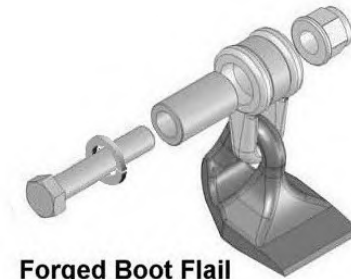

Forged Boot Flail
(Part No. 7190462)

Hedge Flails

Double edged flail designed specifically for heavy duty hedge cutting - capable of cutting materials up to 75/80mm diameter. Can be used for mowing work where they produce a good finish but will require considerably more power and reduced forward speed when used for this purpose.

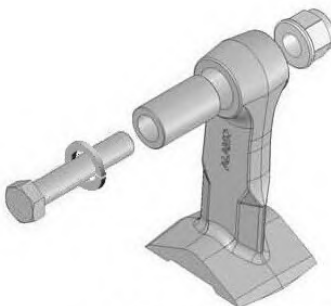

F10 D.E. Forged Flail
(Part No. 41391.02)



F10 D.E. Cast Flail
(Part No. 7314366D)

NOTE: Cast flails are more suitable where the work is predominantly hedge cutting as they maintain a sharper cutting edge – forged versions possess a higher degree of durability and are therefore more suitable where the primary function is mowing work and there is increased risk of hitting foreign objects.

Hedge Flails

Double edged flail designed specifically for heavy duty hedge cutting, capable of cutting materials up to 75/80mm diameter. Can be used for mowing work where they produce a good finish but will require considerably more power when used for this purpose. The flails are fitted with rubber stops for both shaft protection and noise reduction purposes.

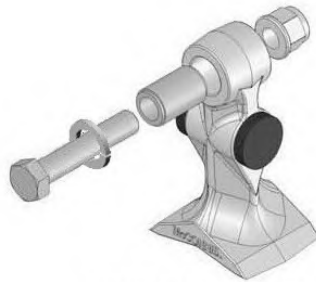

F16 D.E. Cast Flail
(Part No. 21904.02)

Competition Flails

Single edged flail designed specifically for heavy duty hedge and grass cutting, capable of dealing with materials up to 75/80mm diameter. When used for mowing work they produce a better finish and performance than double edged flails requiring less power and increased forward speed.

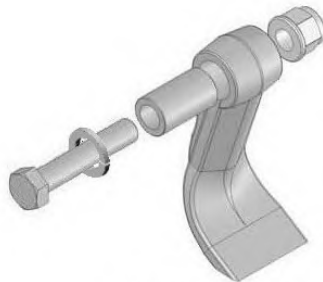

F10 S.E. Cast Flail
(Part No. 7390276)

Omega Flails

Double edged flail for use on 'Omega' rotors only - designed specifically for heavy duty hedge cutting where they are capable of cutting materials up to 75/80mm diameter. Unique rotor design allows the flail to rotate 360° on its pivot protecting the flail on impact with immovable objects. Not suitable for mowing work.

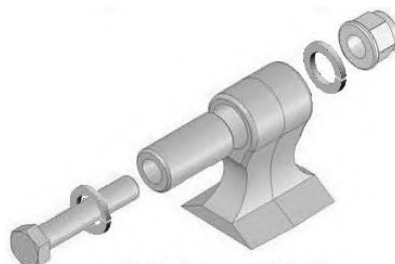

D.E. Omega Flail
(Part No. 7190464)

GENERAL MAINTENANCE

General Lubrication

The illustration below indicates the general locations of lubrication points - all points should be greased on a daily basis and always prior storage of the machine. New machines and PTO shaft must be greased prior to initial use.

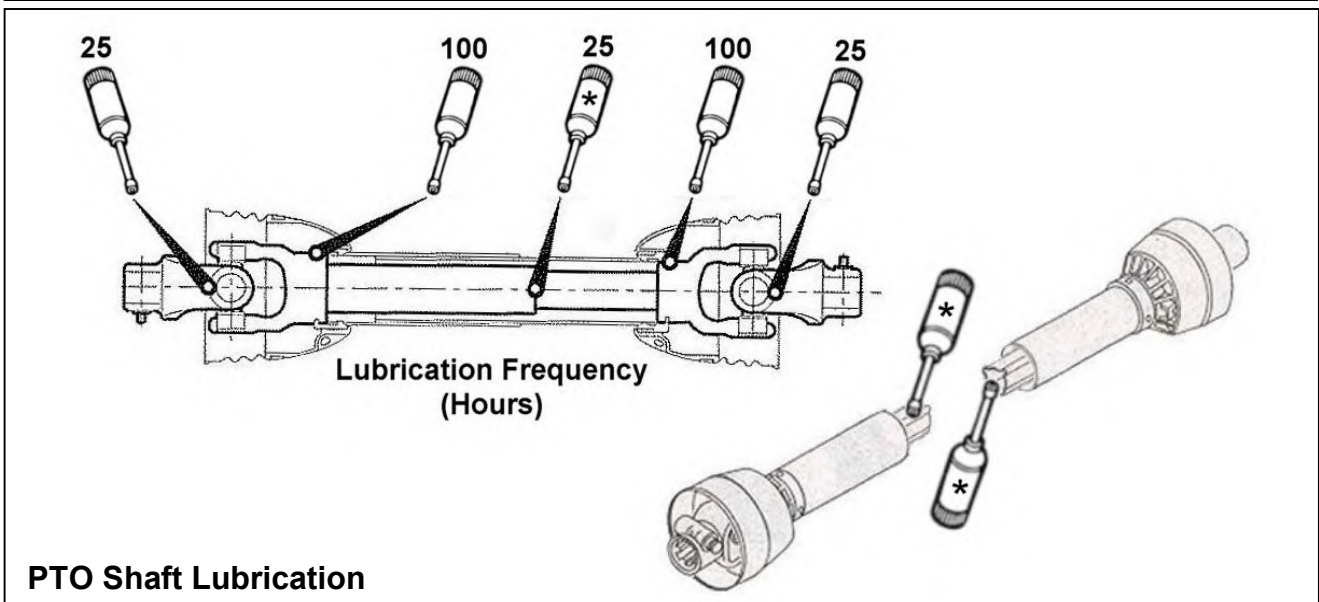
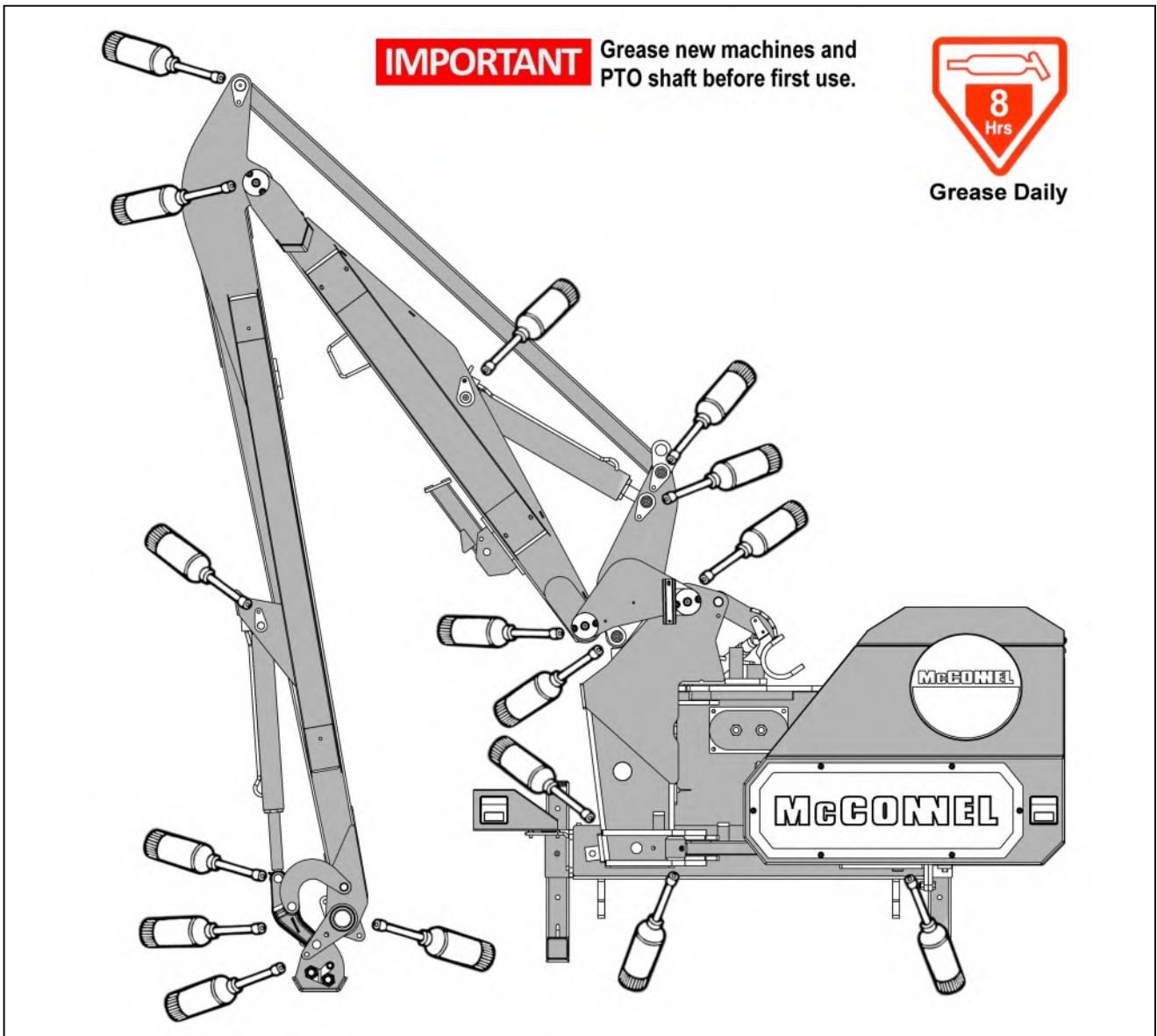

PTO Gearbox

Check gearbox oil level on new machines prior to first use, top up if required before using the machine. **Replace gearbox oil after an initial 50 hours of use** and thereafter at annual or 500 hour intervals; whichever occurs earliest.

Gearbox Capacity (Machines ► 11/13)
0.7 Litre SAE75W90 Fully Synthetic which meets the following minimum requirements;

Viscosity at 40°C, cSt, 100.0 min.
 Viscosity at 100°C, cSt, 17.2 min.

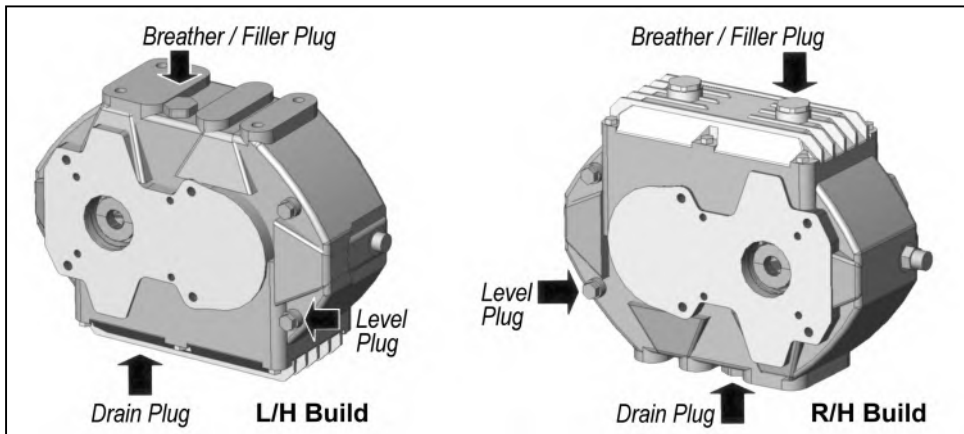

Drainage of the gearbox for an oil change is via the drain plug located on the base of the gearbox.

To refill or for 'topping up' remove filler and level plugs indicated opposite and fill gearbox via the filler plug to a point where the oil starts to run from the level plug orifice. Replace both plugs and tighten.

Gearbox Capacity (Machines 11/13 ►)

0.6 Litre SAE75W90 Fully Synthetic which meets the following minimum requirements;

Viscosity at 40°C, cSt, 100.0 min.
 Viscosity at 100°C, cSt, 17.2 min.

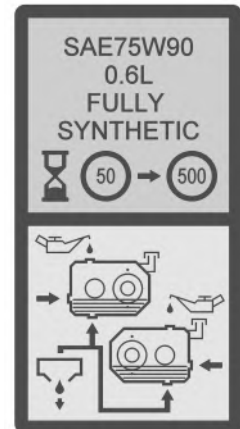
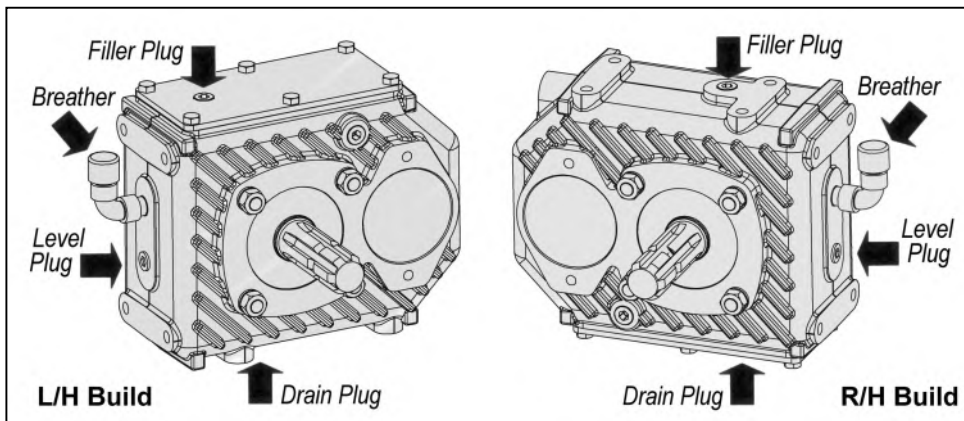

Planetary Gearbox Capacity

0.5 Litre SAE75W90 Fully Synthetic which meets the following minimum requirements;

Viscosity at 40°C, cSt, 100.0 min.
 Viscosity at 100°C, cSt, 17.2 min.

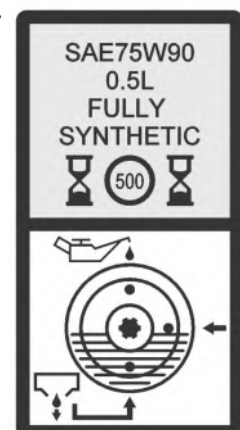
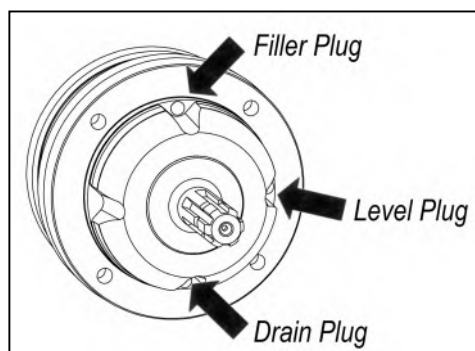

SERVICE SCHEDULE

Every Day	
<ul style="list-style-type: none">• Grease machine fully prior to work (and prior to storage). NOTE: New machines <u>must be fully greased</u> before initial use.• Check for broken or damaged flails.• Check tightness of flail nuts and bolts.• Visually check for oil leaks and damaged hoses.• Check all guards and safety shields are correctly fitted and undamaged.• Ensure all lights are working and clean.• Check oil level.• Clean cooler matrix; in dusty conditions more frequent cleaning is required.	
After initial 50-hours	
<ul style="list-style-type: none">• Change gearbox oil.	
Every 25-hours	
<ul style="list-style-type: none">• Grease PTO Shaft universal joints and tubes.	
Every Week	
<ul style="list-style-type: none">• Check tightness of all nuts and bolts.• Check gearbox oil level.• Check for wear on telescopic arm pads – <i>where applicable</i>.	
Every 100-hours	
<ul style="list-style-type: none">• Grease PTO shaft shield lubrication points.• Check bushes for wear; <i>wherever possible, remove end caps to allow inspection</i>.	
Every 500-hours	
<ul style="list-style-type: none">• Change return line filter element (<i>500-hours or annually, whichever occurs first</i>).• Change tank breather.• Change gearbox oil.• Check condition of hydraulic oil and change if required; <i>when changing the oil, new return line filter and suction strainer elements should be fitted and the return line filter changed again after 100 hours of work</i>.	
Annually	
<ul style="list-style-type: none">• Change tank breather.	

Cooler Matrix

To ensure maximum cooler efficiency, the cooler matrix must be kept as clean as possible to allow free air flow through the unit; this is especially important in dry hot arduous conditions where the matrix can rapidly become blocked by dust causing overheating. Cooler units are best cleaned using a high-pressure air line that will clear blocked areas without risking damage to the matrix.

HYDRAULIC SYSTEM

Oil Supply

Check the oil level in the reservoir daily.

Oil Condition & Replacement

No fixed time period can be quoted for oil changes as operating conditions can vary widely but a visually inspection of the oil will often indicate its current overall state. Signs of a reduction in its condition will be apparent by changes in colour and appearance when compared to new oil. Oil in poor condition can be dark, smell rancid or burnt, or in some cases be yellow, unclear or milky in appearance indicating the presence of air or emulsified water. Moisture resulting from condensation can become entrapped in the oil causing emulsification that can block the return line filter, consequentially the filter system will be by-passed and the oil and any possible contaminants present will continue to circulate without filtration risking damage to hydraulic components. All are indications or conditions that will require replacement of the oil.

Hydraulic oil is a vital component of the machine; contaminated oil is the root cause of 70% of all hydraulic system failures. Contamination can be reduced by the following;

- *Cleaning around the reservoir cap before removal, and keeping the tank area clean.*
- *Use of clean containers when replenishing the system.*
- *Regular servicing of the filtration system.*

Filtration System

Machines are protected by both replaceable 125 micron suction strainers and low pressure 10 micron full flow return line filters – the diagram below is a ‘scaled up’ view illustrating the filtering capability built into the hydraulic system of the machine:

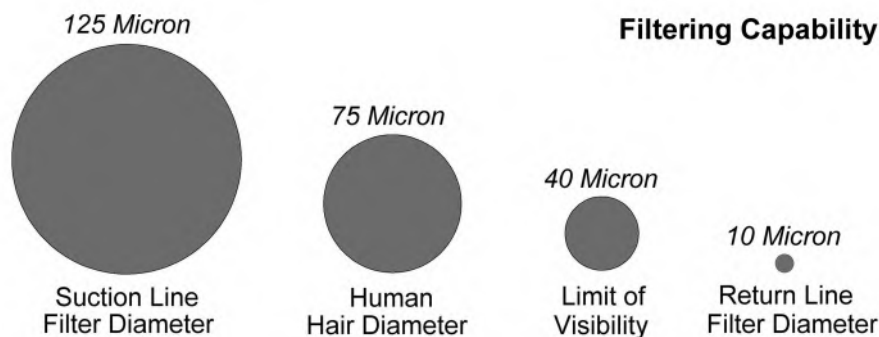

Suction strainers – Stops large contamination in the oil entering the pump

The replaceable 125 micron suction strainers (*Part No. 8401097*) are fitted within the hydraulic tank and are ‘screw’ fitted with easy access for removal and replacement.

Return Line Filter– Stops small contamination in the oil entering the hydraulic tank

The 10 micron absolute filter elements (*Part No. 8401106*) should be changed at 500-hour intervals or annually, *whichever occurs first*. It is important to note hours worked as if the filter becomes blocked an internal by-pass within the canister will operate and no symptoms of filter malfunction will occur to jog your memory.

Tank Breather – Stops contamination from the air mixing with the oil

To reduce the risk of pump cavitation the 10 micron absolute tank breather (*Part No. 8401137*) should be changed at 500-hour intervals or annually, *whichever occurs first*.

For machines operating in dry dusty environments it is recommended that replacement be increased to 250-hour intervals or every 6 months, *whichever occurs first*.

⚠ WARNING

The breather pressurises the fluid trapped in the tank up to 0.3Bar; this is to reduce pump cavitation and reduces the air flow through the breather - extending the filter life.

To avoid danger; unscrew the breather two revolutions and then wait until pressure in tank is equal to the atmosphere - the breather can then be removed safely.

It is advisable to remove any pressure in the tank before working on the hydraulics as this will reduce the amount of oil split.

⚠ WARNING Hot Oil & Hot Components

Never attempt to perform service or maintenance work on the machine's hydraulic system whilst the components and/or their contained oils are hot; machines must be allowed to cool down to a safe temperature state before performing any repairs, service or maintenance tasks.

HYDRAULIC HOSES

The condition of all hoses should be carefully checked during routine service of the machine. Hoses that have been chaffed or damaged on their outer casing should be securely wrapped with waterproof adhesive tape to stop the metal braid from rusting. Hoses that have suffered damage to the metal braid should be changed at the earliest opportunity.

Hose Replacement

- Replace one hose at a time to avoid the risk of wrong connections.
- When the hose is screwed to an additional fitting or union, use a second spanner on the union to avoid breaking both seals.
- Do not use jointing compound on the threads.
- Avoid twisting the hose. Adjust the hose line to ensure freedom from rubbing or trapping before tightening hose end connections.

Before changing hoses study the installation these are carefully calculated to prevent hose damage during operation. Always replace hoses in exactly the same manner. This is especially important for the flail hoses where they must be crossed, upper to lower, at the dipper and head pivots.

All BSP Hydraulic Hoses fitted to McConnel Power Arms have 'Soft Seal' connections on the flail circuit and ram circuit.

Recommended torque settings for nut security:

	Nut Size	Nm	Ft-lbs	O-Ring
	1/4" BSP	24	18	P/No. 10.000.01
	3/8" BSP	33	24	P/No. 10.000.02
	1/2" BSP	44	35	P/No. 10.000.03
	5/8" BSP	58	43	P/No. 10.000.04
	3/4" BSP	84	62	P/No. 10.000.05
	1" BSP	115	85	P/No. 10.000.06

Recommended torque settings for BSP hose unions fitted in conjunction with bonded seals:

	Union Size	Nm	Ft-lbs	Bonded Seal
	1/4" BSP	34	25	P/No. 8650102
	3/8" BSP	75	55	P/No. 8650103
	1/2" BSP	102	75	P/No. 8650104
	5/8" BSP	122	90	P/No. 8650105
	3/4" BSP	183	135	P/No. 8650106
	1" BSP	203	150	P/No. 8650108

Safety Note

The soft seal hose connections are capable of holding pressure when the nut is only finger tight, it is therefore recommended when dismantling that the hose be manually flexed with the retaining nut slackened to relieve any residual pressure prior to complete disassembly.

TOP LINK DAMPER

Machines are equipped with a rubber top link damper; this protects the tractor's top link attachment point by absorbing the effects of any sudden weight transfer when transporting the machine over rough terrain.

The rubber damper should be compressed between the reaction plates to a width of approximately 110mm (4¼") and secured in place with lock nuts.

Check damper width and tightness of lock nuts on a regular basis; re-tighten as and when required.

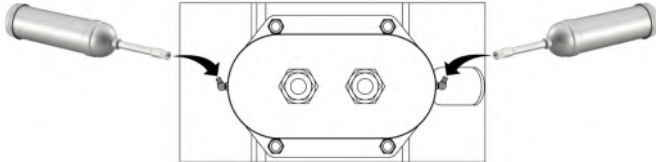

Lubrication points are located on both sides of the front reaction plate; these lubrication points should be greased regularly to reduce wear on damper compression bolts.

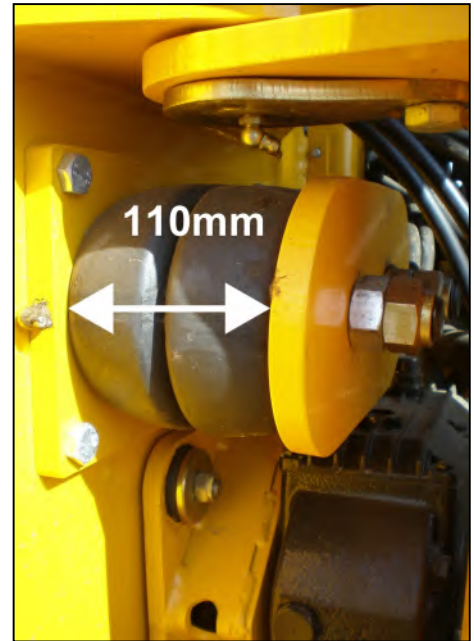

COVERS REMOVAL

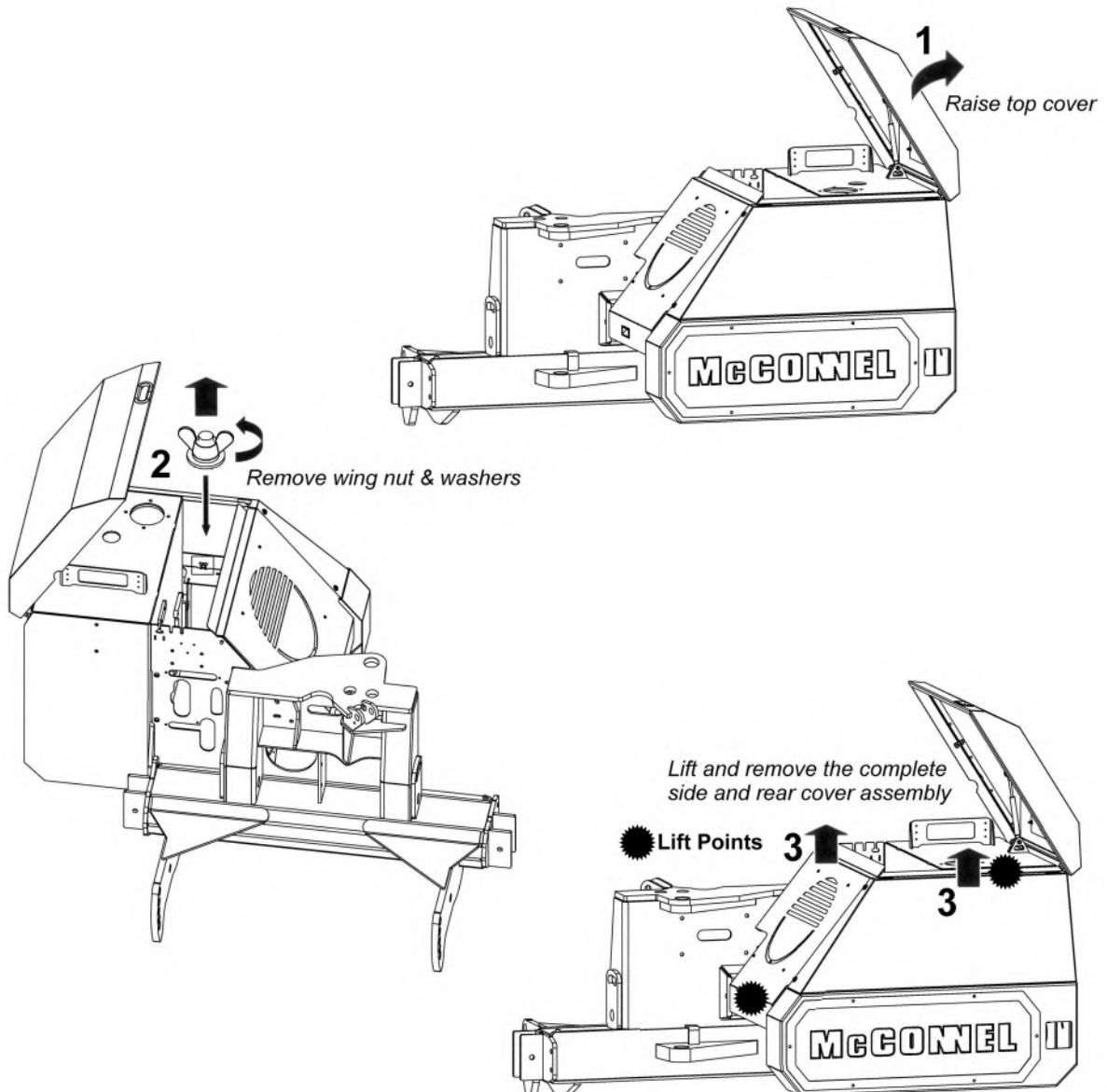

ELECTRICAL CONNECTIONS – Proportional Models

Proportional Control Valve - Loom Installation

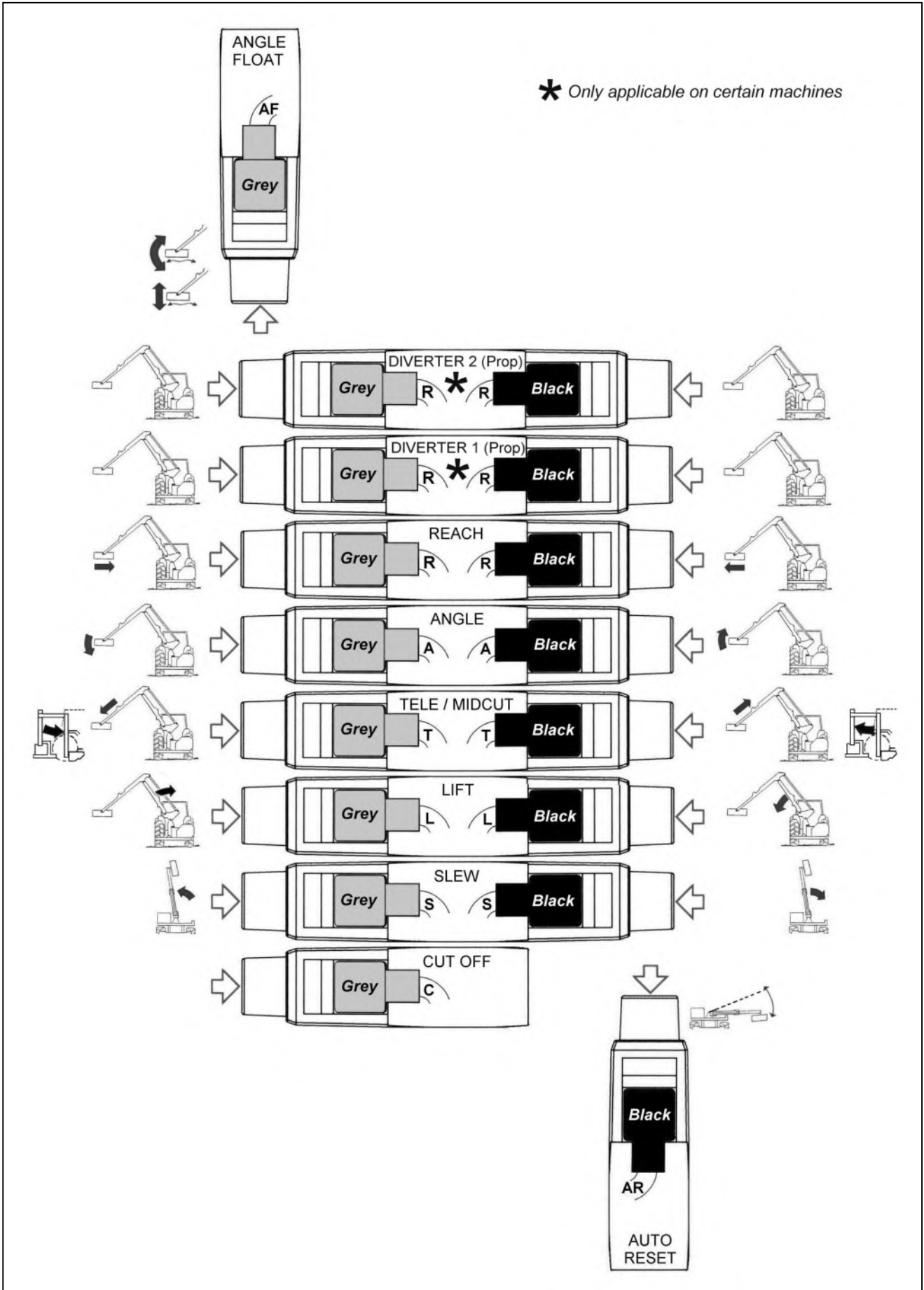

AUXILIARY BOX WIRING – Proportional Models

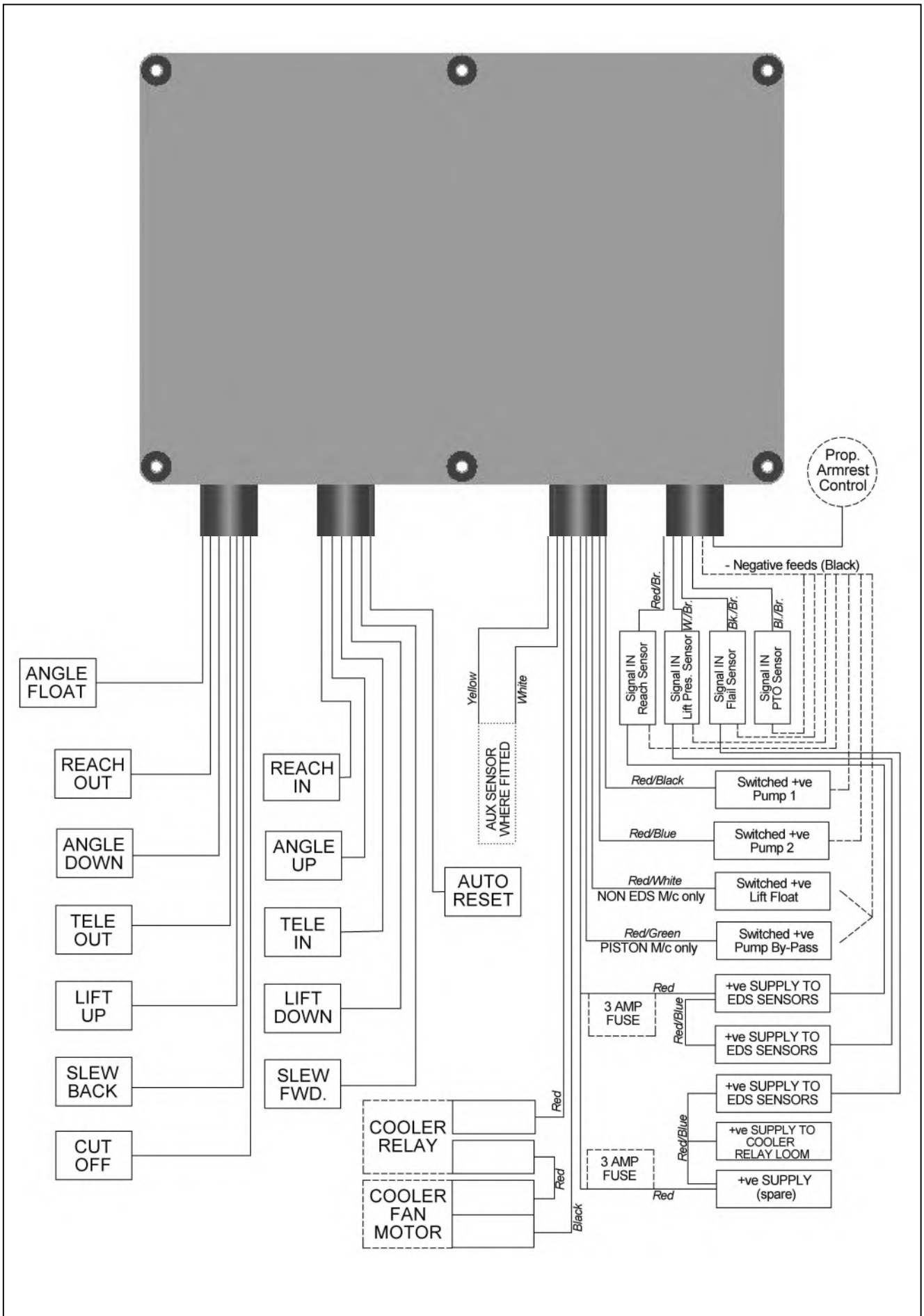

PTO SHAFT MAINTENANCE

PTO Shaft Lubrication

The PTO shaft should be lubricated on a regular basis using lithium based grease – each end of the shaft has 2 greasing points; one for lubrication of the universal joint and one for lubricating the rotating fixing ring of the shaft shield – access to the lubrication points is gained by releasing the shaft shield from its fixing ring and sliding it back along the body of the driveshaft – *the procedure and lubrication frequency is illustrated below.*



Shaft shield fixing clasps



Insert screwdrivers into the clasps

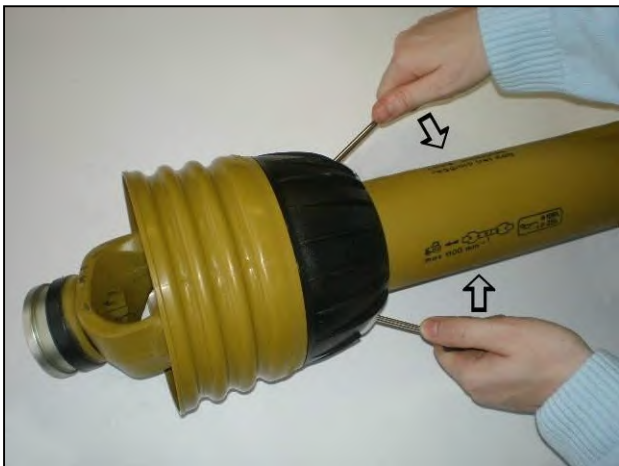

Prise clasps open to release the shield



Slide shield back to reveal universal joint

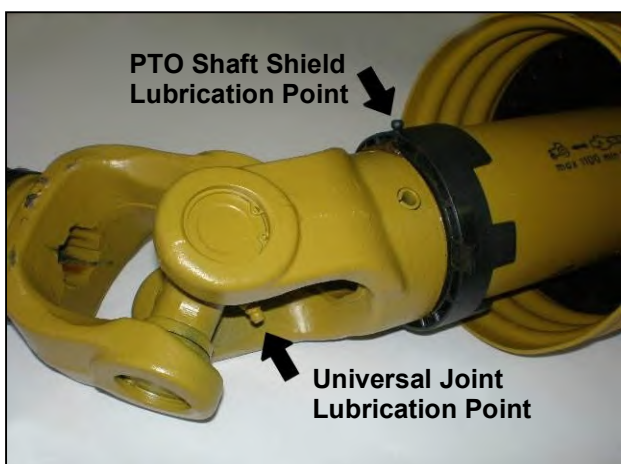

Location of lubrication points



Recommended lubricating frequency

Slide the shaft shield back into place after lubrication ensuring the clasps relocate correctly in the fixing ring – always fit torque chains to the shields to stop them from rotating with the shaft during operation.

TELE ARM WEAR PADS

Over a period of time during normal use the contact faces of the replaceable wear pads will erode due to friction generated from the sliding surfaces of the tele arm – the wear rate of these nylon compound pads may vary considerably and will be determined by the frequency of use of the telescopic function. To accommodate for pad wear the side and upper pusher plates located at the two wear pad stations on the socket arm will each offer approximately 9mm of adjustment.

Wear of the pads should be checked on a regular basis by measuring the gap between the pads and the tele arm using a feeler gauge at the open end of the socket arm - if the gap is in excess of 1mm the pusher plates will need to be adjusted. *NOTE: The tele arm should be fully retracted before attempting to loosen or adjust the pusher plates.*

Wear pads will need replacing when their respective pusher plate comes into contact with the outer arm and no further adjustment is possible – *always replace the pads in opposing sets.*

Refer to the following sections for details of wear pad installation and adjustment.

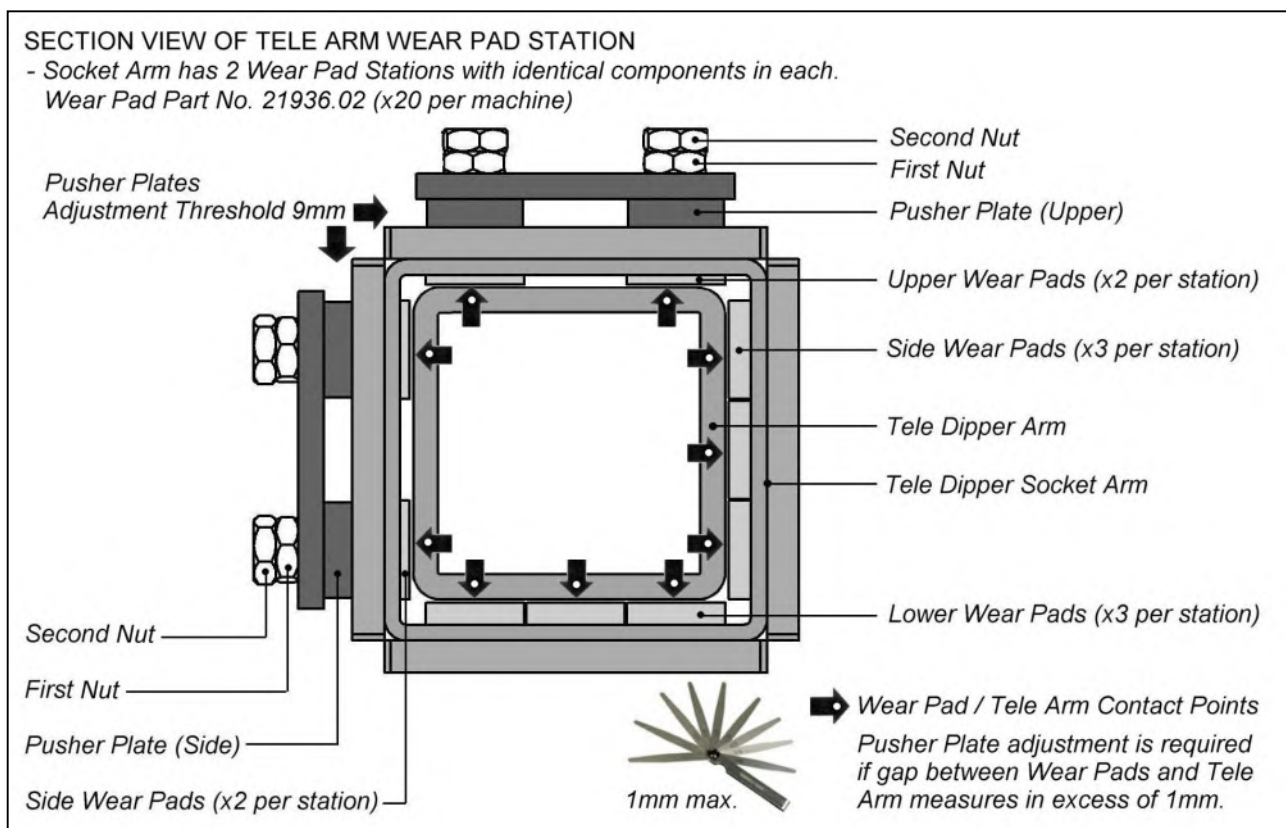

Wear Pad Installation

Replacement of the tele arm wear pads will necessitate the removal of the following components in order to remove the tele dipper arm from the dipper arm socket:

- Removal of the flail head.
- Disconnection of the flail head hoses from the angling gear.
- Removal of the lower end fixings of the rigid flail pipes.
- Disconnection of the angling ram's hoses.
- Removal of the tele ram (piston rod end) from the tele dipper arm.
- Release of the pusher plates and withdrawal of the tele dipper arm from its socket.

With the dipper arm socket and telescopic dipper separated coat the inner surfaces of the socket arm and outer surfaces of the tele arm with wax oil prior to re-assembly this will serve to both protect and lubricate the arms - this procedure should be performed in a clean and dry dust free environment to ensure the lubricated sliding surfaces of the arms do not become contaminated by dirt, grit or moisture.

Prior to insertion of the tele dipper into the socket arm the 12 inner wear pads should be assembled within the dipper arm socket – 6 are located midway within the arm and 6 are located at the 'open' end of the arm, in both locations the pads are fitted in sets of 3's to the both the lower and one side surface of the arm (when viewed from the 'open end' of the arm these side surfaces will be to the right hand side on left hand machines and the left hand side on right hand machines). *Note: A few 'dabs' of grease placed on the backs of inner wear pads will help to keep them in position during the assembly procedure.*

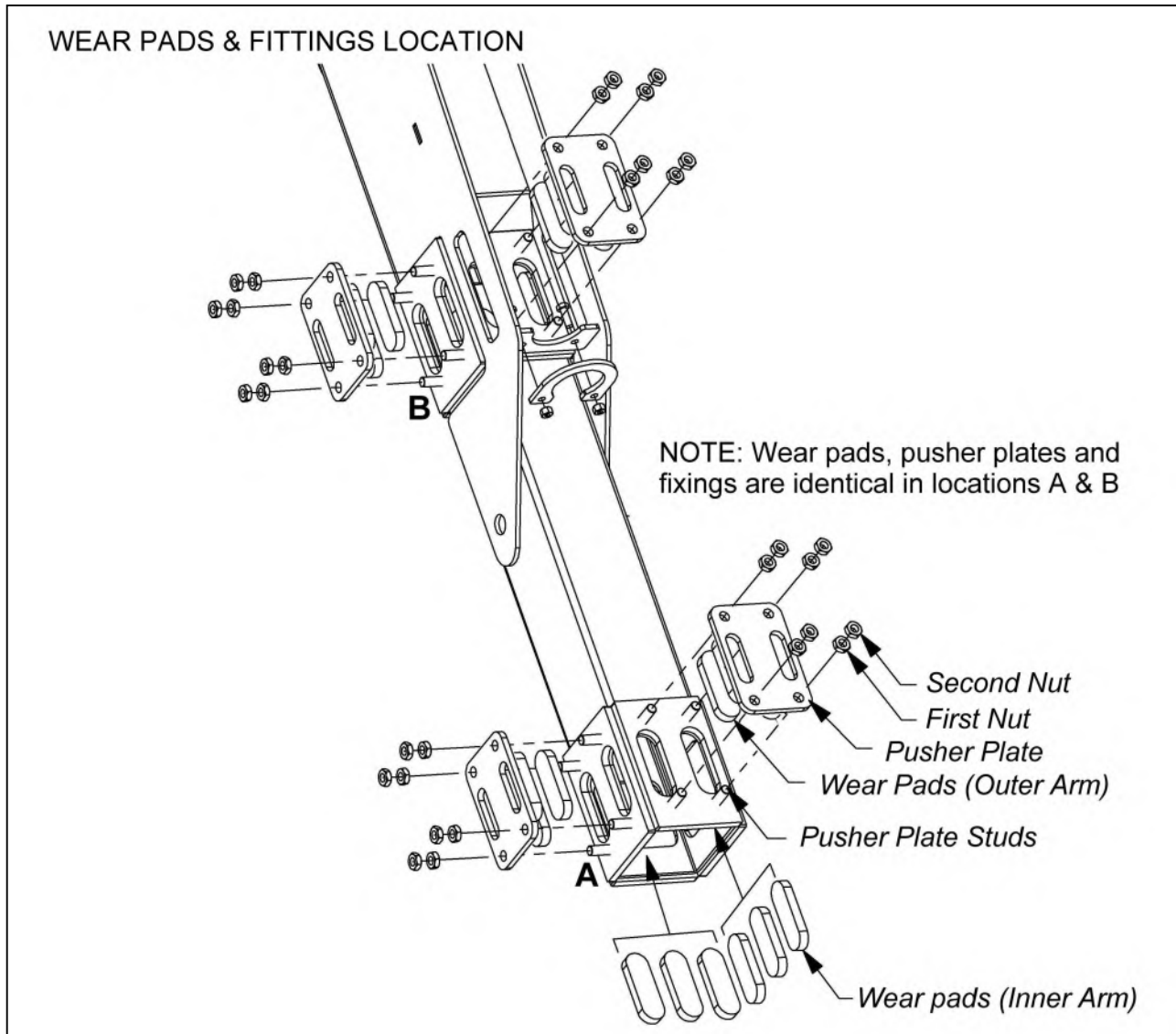

The tele arm may now be inserted into the socket arm (care should be adopted to avoid dislodging the inner wear pads), slide the tele arm into the socket to its furthest point. Place the outer wear pads (8 in total) into their slots in the socket arm and fit the pusher plates over the studs and retain 'loosely' in place with the first set of nuts.

Adjustment

When all pads and pusher plates have been located correctly tighten each set in a cross sequence to a torque setting of 20 Nm. When they have all have been tightened they should then be 'slackened back' by 1/2 a turn; *the tele arm will now be held securely in place but capable of being slid with a slight degree of effort.* Assemble the second set of nuts on the studs and evenly tighten them against the first set to a torque setting of 50 Nm.

NOTICE

When tightening second sets of nuts the first nuts should be held in position with a spanner to ensure their correct torque setting is retained.

The tele arm should now be extended out to its furthest point and a coating of good quality agri-grease applied to its sliding surfaces. Re-attach all components previously removed to complete the job.

WEAR PAD PUSHER PLATE ADJUSTMENT

Fit all sets of first nuts finger tight

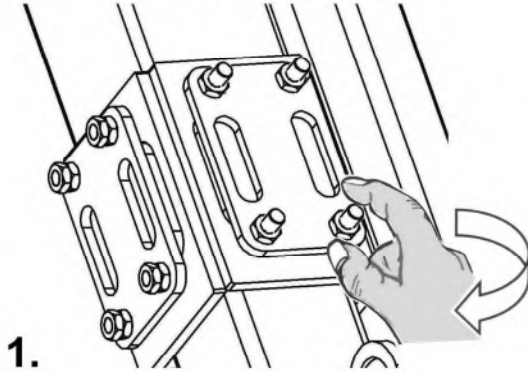

Tighten pusher plates in a cross sequence

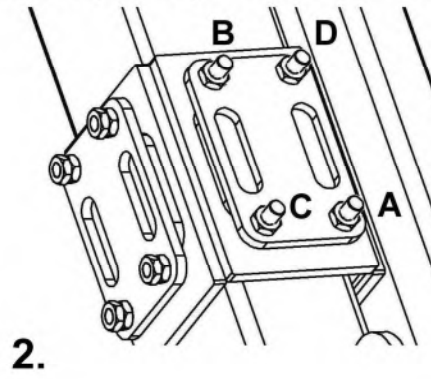

Evenly torque all sets of first nuts to 20 Nm.

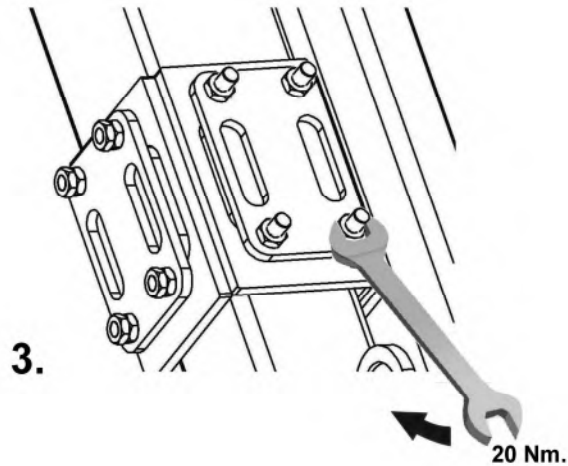

Slacken off each set by 1/2 turn

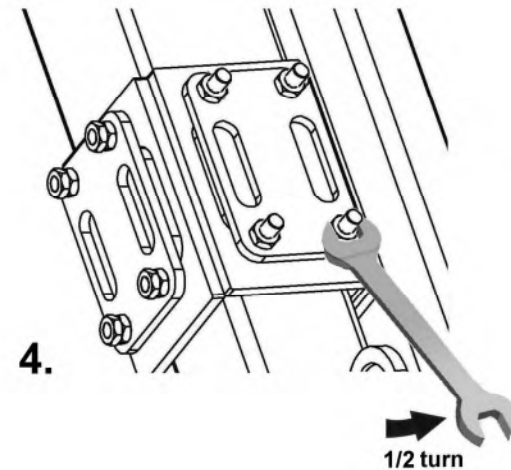

Fit all sets of second nuts finger tight

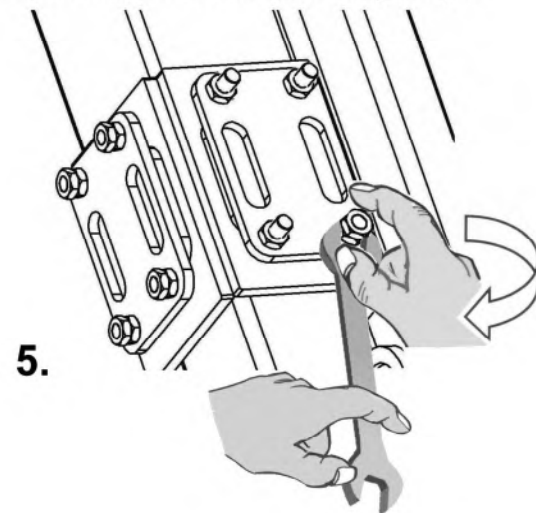

Evenly torque second sets of nuts to 50 Nm.

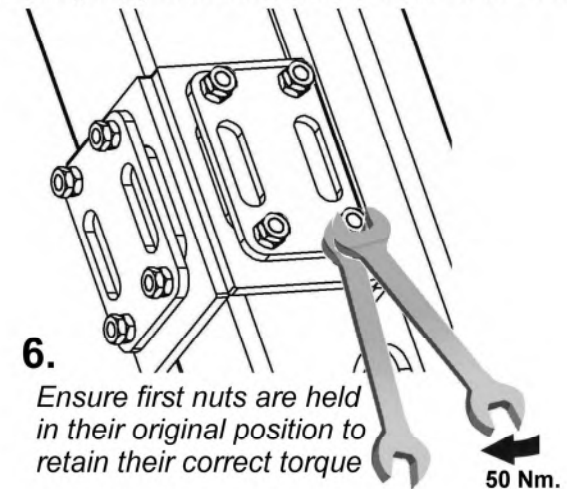

TORQUE SETTINGS FOR FASTENERS

The chart below lists the correct tightening torque for fasteners. This chart should be referred to when tightening or replacing bolts in order to determine the grade of bolt and the correct torque unless specific torque values are assigned in the text of the manual.

Recommended torque is quoted in Foot-Pounds and Newton-Metres within this manual. The equation for conversion is 1 Nm. = 0.7376 ft.lbs.

TORQUE VALUES FOR IMPERIAL BOLTS

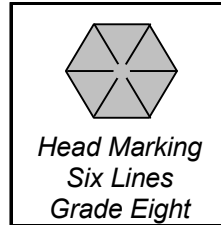
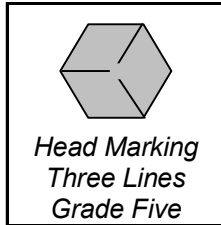
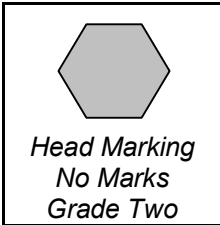

NOTE:
The values in the chart apply to fasteners as received from the supplier, dry or when lubricated with normal engine oil. They DO NOT apply if special graphited, molydisulphide greases, or other extreme pressure lubricants are used. This applies to both UNF and UNC coarse threads.

Bolt Dia.
1/4"
5/16"
3/8"
7/16"
1/2"
9/16"
5/8"
3/4"
7/8"
1"
1-1/8"
1-1/4"
1-3/8"
1-1/2"

Value (Dry)	
ft.lb.	Nm.
5.5	7.5
11	15.0
20	27.0
32	43.0
50	68.0
70	95.0
100	135.0
175	240.0
175	240.0
270	360.0
375	510.0
530	720.0
700	950.0
930	1250.0

Value (Dry)	
ft.lb.	Nm.
9	12.2
18	25.0
33	45.0
52	70.0
80	110.0
115	155.0
160	220.0
280	380.0
450	610.0
675	915.0
850	115.0
1200	1626.0
1550	2100.0
2100	2850.0

Value (Dry)	
ft.lb.	Nm.
12.5	17.0
26	35.2
46	63.0
75	100.0
115	155.0
160	220.0
225	305.0
400	540.0
650	880.0
975	1325.0
1350	1830.0
1950	2650.0
2550	3460.0
3350	4550.0

TORQUE VALUES FOR METRIC BOLTS.

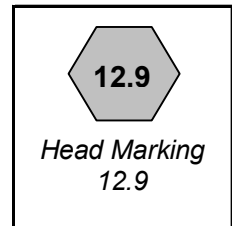
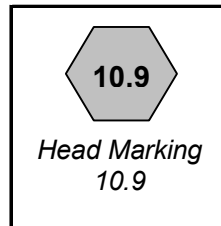
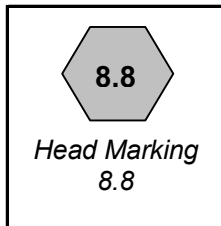
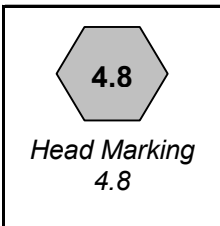

Bolt Dia.
6mm
8mm
10mm
12mm
14mm
16mm
18mm
20mm
22mm
24mm
27mm
30mm

Value (Dry)	
ft.lb.	Nm.
4.5	6.1
11	14.9
21	28.5
37	50.2
60	81.4
92	125.0
125	170.0
180	245.0
250	340.0
250	340.0
310	420.0
450	610.0
625	850.0

Value (Dry)	
ft.lb.	Nm.
8.5	11.5
20	27.1
40	54.2
70	95.0
110	150.0
175	240.0
250	340.0
350	475.0
475	645.0
600	810.0
875	1180.0
1200	1626.0

Value (Dry)	
ft.lb.	Nm.
12	16.3
30	40.1
60	81.4
105	140.0
165	225.0
255	350.0
350	475.0
500	675.0
675	915.0
850	1150.0
1250	1700.0
1700	2300.0

Value (Dry)	
ft.lb.	Nm.
14.5	20.0
35	47.5
70	95.0
120	160.0
190	260.0
300	400.0
410	550.0
580	790.0
800	1090.0
1000	1350.0
1500	2000.0
2000	2700.0

TROUBLESHOOTING CHART

The chart below lists possible causes and solutions to problems that may be encountered.

PROBLEM	POSSIBLE CAUSE	SOLUTION
Gearbox overheating	Oil level incorrect	Check oil level
	Oil grade incorrect	Check oil grade
	Implement overloaded	Reduce forward speed
	Wrong PTO speed	Ensure tractor PTO speed matches implement
Excessive belt wear	Belt and pulley condition	Replace if necessary
	Pulley alignment	Check alignment
	Incorrect belt tension	Tension belts to spec
	Overloading of implement	Reduce forward speed or increase cut height
PTO wear / UJ failure	Working angle too great	Reduce mis-alignment of drive stub shafts
	Shaft length incorrect; bottoming out	Resize PTO shaft as recommended
	Lack of maintenance	Grease PTO shaft as recommended
Cut Quality	Flails worn or damaged	Replace worn/damaged flails
	Rotor speed / direction	Check rotor direction/tractor PTO speed
	Cutting conditions	Work in suitable cutting conditions
Rotor bearing failure	Rotor out of balance	Refer to rotor vibration below
	Wire / string in bearing	Remove wire / string
	Lack of maintenance	Grease bearings to schedule
	Moisture in bearing(s)	Grease bearing(s) to expel moisture
Rotor vibration	Flails broken or missing	Replace flails
	Bearings worn or damaged	Replace bearings
	Rotor unbalanced / bent	Re-balance / replace rotor
	Debris build up	Remove debris
	Incorrect speed	Check rotor RPM
Oil tank overheating	Oil level incorrect	Fill tank to correct level
	Oil grade incorrect	Drain and refill tank with correct grade oil
	PTO speed too fast	Match the tractor's PTO speed to machine
	Ambient temperature too high	Reduce work rate / install oil cooler
	Machine overloaded	Reduce forward speed or increase cut height
Frequent Break-back	Machine overloaded	Reduce forward speed or increase cut height
	Working on excessive incline	Disable auto-reset
	Machine weight sat on rear roller	Raise head or operate with head float
	Machine not set vertical	Adjust top link
	Internal valve leakage	Contact local dealer or McConnel Service
Hydraulics not responding	Oil level low	Fill oil to correct level
	Oil pump suction filter blocked	Replace filter element
	Oil leak in pressure line	Check machine for hydraulic leaks
	Drive line broken	Check pump is rotating
Irregular arm movement	Spool contacting with housing	Check spool moves freely
	Broken spring in spool valve	Check spring in spool valve
	Ram seal failure	Replace ram seals
Electric valve unresponsive	Faulty wiring	Check wiring and switches
	Dirt in valve	Check for ingress of dirt
	Sticking valve	Replace the valve
	Insufficient voltage	Ensure power is sourced direct from battery



McConnel Limited, Temeside Works, Ludlow, Shropshire SY8 1JL. England.
Telephone: 01584 873131. Facsimile: 01584 876463. www.mcconnel.com