

Publication 477
May 2005
Part No. 41570.77
Revised: 14.08.12



PA8000M

MID-MOUNT

Operator Manual

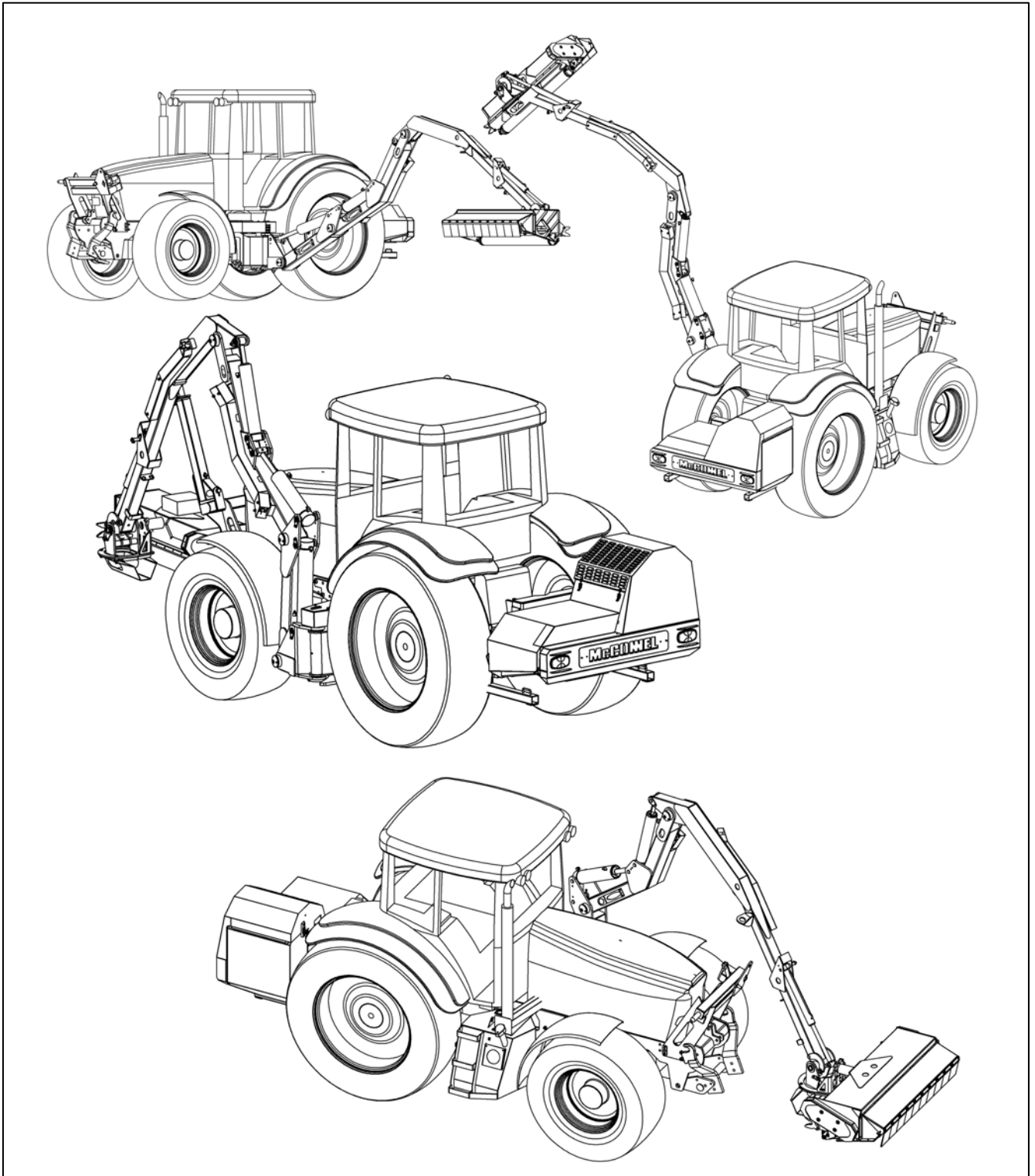

IMPORTANT

VERIFICATION OF WARRANTY REGISTRATION



DEALER WARRANTY INFORMATION & REGISTRATION VERIFICATION

It is imperative that the selling dealer registers this machine with McConnel Limited before delivery to the end user – failure to do so may affect the validity of the machine warranty.

To register machines go to the McConnel Limited web site at www.mcconnel.com, log onto 'Dealer Inside' and select the 'Machine Registration button' which can be found in the Service Section of the site. Confirm to the customer that the machine has been registered in the section below.

Should you experience any problems registering a machine in this manner please contact the McConnel Service Department on 01584 875848.

Registration Verification

Dealer Name:
Dealer Address:
Customer Name:
Date of Warranty Registration:/...../..... Dealer Signature:

NOTE TO CUSTOMER / OWNER

Please ensure that the above section above has been completed and signed by the selling dealer to verify that your machine has been registered with McConnel Limited.

IMPORTANT: During the initial 'bedding in' period of a new machine it is the customer's responsibility to regularly inspect all nuts, bolts and hose connections for tightness and re-tighten if required. New hydraulic connections occasionally weep small amounts of oil as the seals and joints settle in – where this occurs it can be cured by re-tightening the connection – *refer to torque settings chart below*. The tasks stated above should be performed on an hourly basis during the first day of work and at least daily thereafter as part of the machines general maintenance procedure.

TORQUE SETTINGS FOR HYDRAULIC FITTINGS

HYDRAULIC HOSE ENDS		
BSP	Setting	Metric
1/4"	18 Nm	19 mm
3/8"	31 Nm	22 mm
1/2"	49 Nm	27 mm
5/8"	60 Nm	30 mm
3/4"	80 Nm	32 mm
1"	125 Nm	41 mm
1.1/4"	190 Nm	50 mm
1.1/2"	250 Nm	55 mm
2"	420 Nm	70 mm

PORT ADAPTORS WITH BONDED SEALS		
BSP	Setting	Metric
1/4"	34 Nm	19 mm
3/8"	47 Nm	22 mm
1/2"	102 Nm	27 mm
5/8"	122 Nm	30 mm
3/4"	149 Nm	32 mm
1"	203 Nm	41 mm
1.1/4"	305 Nm	50 mm
1.1/2"	305 Nm	55 mm
2"	400 Nm	70 mm

WARRANTY POLICY

WARRANTY REGISTRATION

All machines must be registered, by the selling dealer with McConnel Ltd, before delivery to the end user. On receipt of the goods it is the buyer's responsibility to check that the Verification of Warranty Registration in the Operator's Manual has been completed by the selling dealer.

1. LIMITED WARRANTIES

- 1.01. All machines supplied by McConnel Limited are warranted to be free from defects in material and workmanship from the date of sale to the original purchaser for a period of 12 months, unless a different period is specified.
- 1.02. All spare parts supplied by McConnel Limited are warranted to be free from defects in material and workmanship from the date of sale to the original purchaser for a period of 6 months.
- 1.03. The manufacturer will replace or repair for the purchaser any part or parts found, upon examination at its factory, to be defective under normal use and service due to defects in material or workmanship. Returned parts must be complete and unexamined.
- 1.04. This warranty does not apply to any part of the goods, which has been subjected to improper or abnormal use, negligence, alteration, modification, fitment of non-genuine parts, accident damage, or damage resulting from contact with overhead power lines, damage caused by foreign objects (e.g. stones, iron, material other than vegetation), failure due to lack of maintenance, use of incorrect oil or lubricants, contamination of the oil, or which has served its normal life. This warranty does not apply to any expendable items such as blades, flails, flap kits, skids, soil engaging parts, shields, guards, wear pads or pneumatic tyres.
- 1.05. Temporary repairs and consequential loss - i.e. oil, downtime and associated parts are specifically excluded from the warranty.
- 1.06. Warranty on hoses is limited to 12 months and does not include hoses which have suffered external damage. Only complete hoses may be returned under warranty, any which have been cut or repaired will be rejected.
- 1.07. Machines must be repaired immediately a problem arises. Continued use of the machine after a problem has occurred can result in further component failures, for which McConnel Ltd cannot be held liable, and may have safety implications.
- 1.08. Except as provided herein, no employee, agent, dealer or other person is authorised to give any warranties of any nature on behalf of McConnel Ltd.
- 1.09. For machine warranty periods in excess of 12 months the following additional exclusions shall apply:
 - 1) Hoses, external seals, exposed pipes and hydraulic tank breathers.
 - 2) Filters.
 - 3) Rubber mountings.
 - 4) External electric wiring.
- 1.10. All service work, particularly filter changes, must be carried out in accordance with the manufacturer's service schedule. Failure to comply will invalidate the warranty. In the event of a claim, proof of the service work being carried out may be required.

NB Warranty cover will be invalid if any non-genuine parts have been fitted or used. Use of non-genuine parts may seriously affect the machine's performance and safety. McConnel Ltd cannot be held responsible for any failures or safety implications that arise due to the use of non-genuine parts.

2. REMEDIES AND PROCEDURES

- 2.01. The warranty is not effective unless the Selling Dealer registers the machine, via the McConnel web site and confirms the registration to the purchaser by completing the confirmation form in the operator's manual.
- 2.02. Any fault must be reported to an authorised McConnel dealer as soon as it occurs. Continued use of a machine, after a fault has occurred, can result in further component failure for which McConnel Ltd cannot be held liable.
- 2.03. Repairs should be undertaken within two days of the failure. Claims submitted for repairs undertaken more than 2 weeks after a failure has occurred, or 2 days after the parts were supplied will be rejected, unless the delay has been authorised by McConnel Ltd.
- 2.04. All claims must be submitted, by an authorised McConnel Service Dealer, within 30 days of the date of repair.
- 2.05. Following examination of the claim and parts the manufacture will pay, at their discretion, for any valid claim the cost of any parts and an appropriate labour allowance if applicable.
- 2.06. The submission of a claim is not a guarantee of payment.
- 2.07. Any decision reached by McConnel Ltd. is final.

3. LIMITATION OF LIABILITY

- 3.01. The manufacturer disclaims any express (except as set forth herein) and implied warranties with respect to the goods including, but not limited to, merchantability and fitness for a particular purpose.
- 3.02. The manufacturer makes no warranty as to the design, capability, capacity or suitability for use of the goods.
- 3.03. Except as provided herein, the manufacturer shall have no liability or responsibility to the purchaser or any other person or entity with respect to any liability, loss, or damage caused or alleged to be caused directly or indirectly by the goods including, but not limited to, any indirect, special, consequential, or incidental damages resulting from the use or operation of the goods or any breach of this warranty. Notwithstanding the above limitations and warranties, the manufacturer's liability hereunder for damages incurred by the purchaser or others shall not exceed the price of the goods.
- 3.04. No action arising out of any claimed breach of this warranty or transactions under this warranty may be brought more than one (1) year after the cause of the action has occurred.

4. MISCELLANEOUS

- 4.01. The manufacturer may waive compliance with any of the terms of this limited warranty, but no waiver of any terms shall be deemed to be a waiver of any other term.
- 4.02. If any provision of this limited warranty shall violate any applicable law and is held to be unenforceable, then the invalidity of such provision shall not invalidate any other provisions herein.
- 4.03. Applicable law may provide rights and benefits to the purchaser in addition to those provided herein.



DECLARATION OF CONFORMITY

Conforming to EU Machinery Directive 2006/42/EC

We,

McCONNEL LIMITED, Temeside Works, Ludlow, Shropshire SY8 1JL, UK

Hereby declare that:

The Product; Tractor Mid-Mounted Hedgecutter / Grass Mower

Product Code; P800

Serial No. & Date Type

Manufactured in; United Kingdom

Complies with the required provisions of the Machinery Directive 2006/42/EC
The machinery directive is supported by the following harmonized standards;

- BS EN ISO 14121-1 (2007) Safety of machinery - Risk assessment, Part 1: Principles Part 2: practical guide and examples of methods.
- BS EN ISO 12100-1 (2010) Safety of machinery - Part 1: Basic terminology and methodology Part 2: Technical principles.
- BS EN 349(1993)+ A1 (2008) Safety of machinery - Minimum distances to avoid the entrapment with human body parts.
- BS EN 953 (1998) Safety of machinery - Guards General requirements for the design and construction of fixed and movable guards.
- BS EN 982(1996)+ A1 (2008) Safety requirements for fluid power systems and their components. Hydraulics

McCONNEL LIMITED operates an ISO 9001:2008 quality management system, certificate number: FM25970.

This system is continually assessed by the;
British Standards Institution (BSI), Beech House, Milton Keynes, MK14 6ES, UK
BSI is accredited by UK Accreditation Service, accreditation number: UKAS 003.
The EC declaration only applies if the machine stated above is used in accordance with the operating instructions.

Signed *Responsible Person*
on behalf of McCONNEL LIMITED

Status: General Manager

Date: May 2011

POWER ARM INSPECTION AND MAINTENANCE

A daily equipment inspection of the tractor and mower should be conducted before the equipment is used. You may use the inspection sheets to assist with these daily inspections. Any damaged or missing guards should be repaired or replaced before operating the mower. Failure to repair the damaged shield can result in objects being thrown from the mower and possibly hitting the operator or bystander.

Inspect the Mower for Safe Operating Condition

- Make sure the driveline guards and shielding are in place and in good repair.
- Inspect the flexible thrown object shielding to assure that they are in place on the front and rear of the mower head and in good repair. Repair or replace any damaged or missing thrown object shields.
- Ensure the mower cutting height is set high enough to reduce the possibility of the mower blades contacting the ground. Actual height will be dependent on the ground conditions. Increase the height when working in rough or undulating conditions.
- Inspect for broken, chipped, bent, missing, or severely worn blades. Replace damaged blades before operating the mower. Ensure the blade retaining bolts and fasteners are secure and tight.
- Ensure all head bolts and nuts are tight.
- Lubricate the driveline universal joints and telescoping members daily.
- Grease the rotor and roller bearings and inspect their condition.
- Inspect for any oil leaks or damaged hoses
- Inspect for worn or damaged decals and safety instructions. Replace unreadable, damaged or missing safety decals.
- Follow the operator's manual(s) inspection and maintenance instructions for lubricating parts, and keeping thrown object shielding, driveline guards, rotating parts shields, mower blades and decals in good repair.

Inspect the Tractor for Safe Operating Condition:

- Inspect the controls, lights, SMVs (Slow Moving Vehicle sign), seat belts, and ROPS to assure that they are in place and in good working order.
- Be sure the tires, wheels, lug bolts/nuts are in good condition.
- Make sure the tractor brakes and steering are in proper operating condition.
- Follow the operator's manual(s) inspection and maintenance procedures for keeping the tractor in good and safe condition before operating.

The inspection sheet on the following page should be kept in this book as a record. A second sheet is included for you to cut out and photocopy or the inspection sheets can be downloaded from our website at;

<http://www.mcconnel.com/support/aftersales/default.aspx?nav=After Sales>



POWER ARM PRE-OPERATION Inspection

Power Arm ID _____ Date: _____ Shift: _____

WARNING



Before conducting the inspection, make sure the tractor engine is off, the key removed, all rotation has stopped and the tractor is in park with the parking brake engaged. Make sure the mower head is resting on the ground or is securely blocked up and supported and all hydraulic pressure has been relieved.

Item	Condition at start of shift	Specific Comments if not O.K.
The Operator's Manual is in the Canister on the mower		
All Warning Decals are in place, clean and legible		
All Lights are clean and working		
The Mounting frame bolts are in place and tight		
The Arm pivot pins are tight and correctly secured		
There are no cracks in the arms		
The Hyd. Cylinder pins are tight and correctly secured		
The Hyd Cylinder hose connections are tight		
The Hyd. Pump hose connections are tight		
The Hyd. Valve hose connections are tight		
The Hyd. Valve controls function properly		
There are no damaged hoses		
The Oil level is to the green mark on the tank sight glass		
There is no evidence of Hydraulic oil leaks		
Flails are not missing, chipped, broken or excessively worn		
The Flail bolts are tight		
The Front & Rear Flaps are fitted and in good condition		
The Front hood is in place and in good condition		
The Wire Trap is in good condition		
The Skid shoes are in good condition & tight		
There are no cracks or holes in flail casing		
The Hyd. motor mounting bolts are tight		
All Flail Head Nuts and Bolts are tight		
The Rotor Bearings are in good condition and greased		
The Roller bearings are in good condition and greased		
The drive line Shaft guard is in good condition		
The drive line shaft guard is correctly secured		
Controls are securely mounted in the cab		
With engine running check arm operation		
Have a spare pack of flails, bushes, bolts and nuts		

Operators Signature: _____

DO NOT OPERATE an UNSAFE TRACTOR or MOWER



TRACTOR PRE-OPERATION Inspection

Power Arm ID _____ Date: _____ Shift: _____

WARNING



Before conducting the inspection, make sure the tractor engine is off, the key is removed all rotation has stopped and the tractor is in park with the parking brake engaged. Any implement attached to the tractor is firmly on the ground.

Item	Condition at start of shift	Specific Comments if not O.K.
The flashing lights function properly.		
All lights are clean and working correctly		
All cab windows are clean and wipers working correctly		
The SMV sign, where required, is clean and visible.		
The tyres are in good condition with correct pressure.		
The wheel nuts are tight.		
The tractor brakes are in good condition.		
The steering linkage is in good condition.		
There are no visible oil leaks.		
The hydraulic controls function properly.		
The ROPS or ROPS cab is in good condition.		
The seatbelt is in place and in good condition.		
The 3-point hitch is in good condition.		
The drawbar/pick up hook is secure & in good condition		
The PTO master shield is in place.		
The engine oil level is full.		
The brake fluid level is full.		
The power steering fluid level is full.		
The fuel level is adequate.		
The engine coolant fluid level is full.		
The radiator & oil cooler are free of debris.		
The air filter is in good condition		

Operators Signature: _____

DO NOT OPERATE an UNSAFE TRACTOR or MOWER



POWER ARM PRE-OPERATION Inspection

Power Arm ID _____ Date: _____ Shift: _____

WARNING



Before conducting the inspection, make sure the tractor engine is off, the key removed, all rotation has stopped and the tractor is in park with the parking brake engaged. Make sure the mower head is resting on the ground or is securely blocked up and supported and all hydraulic pressure has been relieved.

Item	Condition at start of shift	Specific Comments if not O.K.
The Operator's Manual is in the Canister on the mower		
All Warning Decals are in place, clean and legible		
All Lights are clean and working		
The Mounting frame bolts are in place and tight		
The Arm pivot pins are tight and correctly secured		
There are no cracks in the arms		
The Hyd. Cylinder pins are tight and correctly secured		
The Hyd Cylinder hose connections are tight		
The Hyd. Pump hose connections are tight		
The Hyd. Valve hose connections are tight		
The Hyd. Valve controls function properly		
There are no damaged hoses		
The Oil level is to the green mark on the tank sight glass		
There is no evidence of Hydraulic oil leaks		
Flails are not missing, chipped, broken or excessively worn		
The Flail bolts are tight		
The Front & Rear Flaps are fitted and in good condition		
The Front hood is in place and in good condition		
The Wire Trap is in good condition		
The Skid shoes are in good condition & tight		
There are no cracks or holes in flail casing		
The Hyd. motor mounting bolts are tight		
All Flail Head Nuts and Bolts are tight		
The Rotor Bearings are in good condition and greased		
The Roller bearings are in good condition and greased		
The drive line Shaft guard is in good condition		
The drive line shaft guard is correctly secured		
Controls are securely mounted in the cab		
With engine running check arm operation		
Have a spare pack of flails, bushes, bolts and nuts		

Operators Signature: _____

DO NOT OPERATE an UNSAFE TRACTOR or MOWER



TRACTOR PRE-OPERATION Inspection

Power Arm ID _____ Date: _____ Shift: _____

WARNING



Before conducting the inspection, make sure the tractor engine is off, the key is removed all rotation has stopped and the tractor is in park with the parking brake engaged. Any implement attached to the tractor is firmly on the ground.

Item	Condition at start of shift	Specific Comments if not O.K.
The flashing lights function properly.		
All lights are clean and working correctly		
All cab windows are clean and wipers working correctly		
The SMV sign, where required, is clean and visible.		
The tyres are in good condition with correct pressure.		
The wheel nuts are tight.		
The tractor brakes are in good condition.		
The steering linkage is in good condition.		
There are no visible oil leaks.		
The hydraulic controls function properly.		
The ROPS or ROPS cab is in good condition.		
The seatbelt is in place and in good condition.		
The 3-point hitch is in good condition.		
The drawbar/pick up hook is secure & in good condition		
The PTO master shield is in place.		
The engine oil level is full.		
The brake fluid level is full.		
The power steering fluid level is full.		
The fuel level is adequate.		
The engine coolant fluid level is full.		
The radiator & oil cooler are free of debris.		
The air filter is in good condition		

Operators Signature: _____

DO NOT OPERATE an UNSAFE TRACTOR or MOWER



READ THE BOOK FIRST

It might save hours and pounds later!

When ordering spare parts always quote

- ***The Machine Type***
- ***The Machine Serial Number***
- ***The Part Number***

Factory re-built service exchange units of the major hydraulic components are available from your Dealer

NOISE

The equivalent daily personal noise exposure from this machine, measured at the operators' ear, is within the range 78 – 85 dB.

These figures apply to a normal distribution of use where the noise fluctuates between zero and maximum. The figures assume that the machine is fitted to a tractor with a quiet cab with the windows closed in a generally open environment. We recommend that the windows are kept closed.

With the cab rear window open, the equivalent daily personal noise exposure will increase to a figure within the range 82 – 88 dB.

At equivalent daily noise exposure levels of between 85 and 90 dB, ear protection is recommended, it should be used if any window is left open.

List of Contents

	<i>Page No.</i>
General Information	1
Features	2
Safety Information	3
Fitting Requirements – <i>Tractor Specification & Axle Locking System</i>	8
Vehicle/Tractor Preparation	9
Rear Tank Frame Attachment & Removal	10
Detaching the Arm Unit – <i>Support & Storage Frame</i>	12
Oil Requirements	15
Control Unit Fitting	15
Pre-Operational Checks	16
Running Up Procedure	16
Operation	17
Preparation	18
V3 Proportional Controls	19
V4 Proportional Controls	23
Head Angle Float	36
Easy Drive System (EDS)	37
Powered Slew	38
Powered Head Rotation	39
Flailhead	40
Flail Selection	42
Transportation Cradle	43
Transporting the Machine	44
Overhead Power Lines	45
Hydraulic Hose Connection Points – <i>Bulkhead Plate</i>	47
Maintenance - <i>Lubrication</i>	48
Maintenance – <i>Hydraulic System</i>	49
Wiring Diagram – <i>Auxiliary Box</i>	50

GENERAL INFORMATION

Read this manual before fitting or operating the machine. Whenever any doubt exists contact your dealer or the McConnell Service Department for assistance.

Use only McConnell Genuine spare parts on McConnell equipment and machines.

DEFINITIONS - the following definitions apply throughout this manual:

WARNING

An operating procedure, technique etc., which can result in personal injury or loss of life if not observed carefully.

CAUTION

An operating procedure, technique etc., which can result in the damage of either machine or equipment if not observed carefully.

NOTE

An operating procedure, technique etc., which is considered essential to emphasise.

LEFT AND RIGHT HAND

This term is applicable to the machine when fitted to the tractor and viewed from the rear. This also applies to tractor references.

Record the serial number of your machine on this page and always quote this number when ordering spares. Remember whenever information concerning the machine is requested to also state the type of tractor to which the machine is fitted.

Machine Serial No.:	Model Details:	Installation Date:
Dealer Name:	Telephone No:	
Address:		

FEATURES

8.0m Mid-Mount

- Full chassis under frame for rigid attachment, tractor specific.
- Quick attach arm set.
- Quick release connections from arm set to rear power pack.
- 3-point linkage mounted rear frame power pack with enclosed hydraulics.
- Right or Left hand cutting.
- 72HP variable servo piston pump flail drive
- Independent reversible, on/off rotor operation.
- Power braking of flail drive when stopping.
- Pressure compensated piston pump powering arm movements.
- Proportional solenoid valves on main services all with manual override.
- Pilot operated check valves on all services to remove ram droop.
- Head angle float.
- Lift float on both 1st and 2nd Arms
- High capacity oil cooler c/w removable easy access easy clean dust guard.
- Proportional controls with LED display.
- Ergonomic joystick allows up to four services to be operated simultaneously.
- Power monitor with readout on display.
- PTO speed sensor with readout on display.
- Operator Guard.
- 30° of Hydraulic Breakaway
- 138° powered slew.
- 240 Litre hydraulic reservoir.
- 125micron abs Suction, 10micron abs medium pressure and 10micron abs return line filters fitted.
- Rear Lighting.
- Front frame fitting kit for stowage of Arm/head during transport
- Choice of 1.6m flailhead and sawhead attachments.



SAFETY INFORMATION

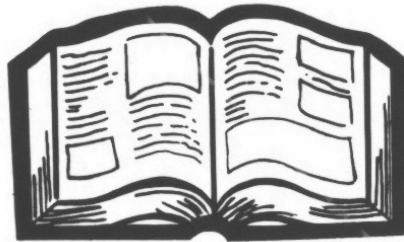

This machine has the potential to be extremely dangerous, in the wrong hands it can kill or maim. It is therefore imperative that both owner, and operator of this machine, read and understand the following section to ensure that they are fully aware of the dangers that do, or may exist, and their responsibilities surrounding the use and operation of the machine. The operator of this machine is responsible not only for their own safety but equally for the safety of others who may come into the close proximity of the machine, as the owner you are responsible for both.

When the machine is not in use the cutting head should be lowered to rest on the ground. In the event of a fault being detected with the machine's operation it should be stopped immediately and not used again until the fault has been corrected by a qualified technician.

POTENTIAL SIGNIFICANT DANGERS ASSOCIATED WITH THE USE OF THIS MACHINE:

- ▲ *Being hit by debris thrown by rotating components.*
- ▲ *Being hit by machine parts ejected through damage during use.*
- ▲ *Being caught on a rotating power take-off (PTO) shaft.*
- ▲ *Being caught in other moving parts i.e.: belts, pulleys and cutting heads.*
- ▲ *Electrocution from Overhead Power Lines (by contact with or 'flashover' from).*
- ▲ *Being hit by cutting heads or machine arms as they move.*
- ▲ *Becoming trapped between tractor and machine when hitching or unhitching.*
- ▲ *Tractor overbalancing when machine arm is extended.*
- ▲ *Injection of high-pressure oil from hydraulic hoses or couplings.*
- ▲ *Machine overbalancing when freestanding (out of use).*
- ▲ *Road traffic accidents due to collision or debris on the road.*

BEFORE USING THIS MACHINE YOU MUST:

- ▲ *Ensure you read all sections of the operator handbook.*
- ▲ *Ensure the operator is, or has been, properly trained to use the machine.*
- ▲ *Ensure the operator has been issued with and reads the operator handbook.*
- ▲ *Ensure the operator understands and follows the instructions in operator handbook.*
- ▲ *Ensure the tractor front, rear and side(s) are fitted with metal mesh or polycarbonate guards of suitable size and strength to protect the operator against thrown debris or parts.*
- ▲ *Ensure tractor guards are correctly fitted, undamaged and kept properly maintained.*
- ▲ *Ensure that all machine guards are in position, are undamaged, and are kept maintained in accordance with the manufacturer's recommendations.*
- ▲ *Ensure flails and their fixings are of a type recommended by the manufacturer, are securely attached and that none are missing or damaged.*
- ▲ *Ensure hydraulic pipes are carefully and correctly routed to avoid damage by chaffing, stretching or pinching and that they are held in place with the correct fittings.*
- ▲ *Always follow the manufacturer's instructions for attachment and removal of the machine from the tractor.*
- ▲ *Check that the machine fittings and couplings are in good condition.*
- ▲ *Ensure the tractor meets the minimum weight recommendations of the machine manufacturer and that ballast is used as necessary.*
- ▲ *Always inspect the work area thoroughly before starting to note obstacles and remove wire, bottles, cans and other debris.*
- ▲ *Use clear suitably sized warning signs to alert others to the nature of the machine working within that area. Signs should be placed at both ends of the work site. (It is recommended that signs used are of a size and type specified by the Department of Transport and positioned in accordance with their and the Local Highways Authority guidelines).*
- ▲ *Ensure the operator is protected from noise. Ear defenders should be worn and tractor cab doors and windows must be kept closed. Machine controls should be routed through proprietary openings in the cab to enable all windows to be shut fully.*
- ▲ *Always work at a safe speed taking account of the conditions i.e.: terrain, highway proximity and obstacles around and above the machine.*
- ▲ *Extra special attention should be applied to Overhead Power Lines. Some of our machines are capable of reach in excess of 8 metres (26 feet) this means they have the potential to well exceed, by possibly 3 metres (9' 9"), the lowest legal minimum height of 5.2 metres from the ground for 11,000 and 33,000 volt power lines. It cannot be stressed enough the dangers that surround this capability, it is therefore vital that the operator is fully aware of the maximum height and reach of the machine, and that they are fully conversant with all aspects regarding the safe minimum distances that apply when working with machines in close proximity to Power Lines. (Further information on this subject can be obtained from the Health & Safety Executive or your Local Power Company).*

- ▲ *Always disengage the machine, kill the tractor engine, remove and pocket the key before dismounting for any reason.*
- ▲ *Always clear up all debris left at the work area, it may cause hazard to others.*
- ▲ *Always ensure when you remove your machine from the tractor that it is left in a safe and stable position using the stands and props provided and secured if necessary.*

WHEN NOT TO USE THIS MACHINE:

- ▲ *Never attempt to use this machine if you have not been trained to do so.*
- ▲ *Never uses a machine until you have read and understood the operator handbook, are familiar with, and practiced the controls.*
- ▲ *Never use a machine that is poorly maintained.*
- ▲ *Never use a machine if guards are missing or damaged.*
- ▲ *Never use a machine on which the hydraulic system shows signs of wear or damage.*
- ▲ *Never fit, or use, a machine on a tractor that does not meet the manufacturer's minimum specification level.*
- ▲ *Never use a machine fitted to a tractor that does not have suitable front, rear and side(s) cab guarding made of metal mesh or polycarbonate.*
- ▲ *Never use the machine if the tractor cab guarding is damaged, deteriorating or badly fitted.*
- ▲ *Never turn a machine cutting head to an angle that causes debris to be ejected towards the cab.*
- ▲ *Never start or continue to work a machine if people are nearby or approaching - Stop and wait until they are at a safe distance before continuing. WARNING: Some Cutting Heads may continue to 'freewheel' for up to 40 seconds after being stopped.*
- ▲ *Never attempt to use a machine on materials in excess of its capability.*
- ▲ *Never use a machine to perform a task it has not been designed to do.*
- ▲ *Never operate the tractor or machine controls from any position other than from the driving seat, especially whilst hitching or unhitching the machine.*
- ▲ *Never carry out maintenance of a machine or a tractor whilst the engine is running – the engine should be switched off, the key removed and pocketed.*
- ▲ *Never leave a machine unattended in a raised position – it should be lowered to the ground in a safe position on a level firm site.*
- ▲ *Never leave a tractor with the key in or the engine running.*
- ▲ *Never carry out maintenance on any part or component of a machine that is raised unless that part or component has been properly substantially braced or supported.*
- ▲ *Never attempt to detect a hydraulic leak with your hand – use a piece of cardboard.*
- ▲ *Never allow children near to, or play on, a tractor or machine under any circumstances.*

FRONT MOUNTED MACHINES – Additional Safety Advice

During transportation and operation of 'Front-Mounted Machinery', the operator should be reminded that the machine is located further away from his point of vision than a rear mounted machine, and in many cases the immediate work area is out of view. Additional care should therefore be applied whilst working with machinery of this nature. The intended work area should be thoroughly scrutinised immediately prior to work to check for potential hidden hazards and dangers, bearing in mind that these many not be identifiable from the operating position on the tractor. Removable objects that may cause a hazard should be removed from the work area and any fixed hazards should be clearly indicated with a visible marker that can easily be seen from the operating position.

The operator should also be reminded that rotating cutting heads will throw debris either forwards or rearwards - dependent upon the nature of the job - it is therefore vital that suitable safety guarding is fitted where danger to either the operator, bystanders or property exists. Tractor windows should be protected with suitable materials of the correct specification to ensure the safety of the operator whilst allowing good all round visibility without impairing the functions of the tractor. Any side guarding fitted to the tractor to protect it from thrown debris should be fitted in such a way that it does not further obscure the operators vision of the machine or the working area. – *Contact your tractor manufacturer or local dealer for advice on this subject.*

ADDITIONAL SAFETY ADVICE

Training

Operators need to be competent and fully capable of operating this machine in a safe and efficient way prior to attempting to use it in any public place. We advise therefore that the prospective operator make use of relevant training courses available such as those run by the Agricultural Training Board, Agricultural Colleges, Dealers and McConnel.

Working in Public Places

When working in public places such as roadsides, consideration should be paid to others in the vicinity. Stop the machine immediately when pedestrians, cyclists and horse riders etc. pass. Restart only when they are at a distance that causes no risk to their safety.

Warning Signs

It is advisable that any working area be covered by suitable warning signs and statutory in public places. Signs should be highly visible and well placed in order to give clear advanced warning of the hazard. Contact the Department of Transport or your Local Highways Authority to obtain detailed information on this subject. The latter should be contacted prior to working on the public highway advising them of the time and location of the intended work asking what is required by way of signs and procedure. – *'Non-authorized placement of road signs may create offences under the Highways Act'.*

SUGGESTED WARNING SIGNS REQUIRED

“Road works ahead” warning sign with a supplementary “Hedge cutting” plate. “For 1 mile” or appropriate shorter distance may be added to the plate.

“Road narrows” warning sign with supplementary “Single file traffic” plate.

White on blue “Keep right” arrow sign on rear of machine.

USE OF WARNING SIGNS

On two way roads one set of signs is needed facing traffic in each direction.

Work should be within 1 mile of the signs.

Work only when visibility is good and at times of low risk e.g.: NOT during ‘rush-hour’.

Vehicles should have an amber flashing beacon.

Ideally, vehicles should be conspicuously coloured.

Debris should be removed from the road and path as soon as practicable, and at regular intervals, wearing high visibility clothing and before removing the hazard warning signs.

Collect all road signs promptly when the job is completed.

Although the information given here covers a wide range of safety subjects it is impossible to predict every eventuality that can occur under differing circumstances whilst operating this machine. No advice given here can replace ‘good common sense’ and ‘total awareness’ at all times but it will go a long way towards the safe use of your McConnel machine.

FITTING - Tractor requirements

Minimum Tractor Weights - including ballast weight if necessary:

7800 kg.

Minimum HP requirements:

120 HP

Linkage:

Category 2 Rear Linkage

PTO shaft:

800 RPM with a 6-spline output required.

AXLE LOCKING BRACKETS

For additional stability of the unit during work an 'Axle Locking System' may be fitted to the tractor. The axle locking system comprises of 2 pairs of brackets attached to the front axle and chassis on each side of the tractor - the axle and chassis brackets are each connected by a hydraulic ram which, when activated via the tractors external service, will lock the axle rigidly to the tractor chassis.

For normal operation the tractor's external service control lever should be set to the float position - *refer to your tractor handbook for operation instructions*. Float position will allow the tractor's suspension to function in the normal manner.

The front suspension is locked by moving the external service control lever to the centre position. When working for long periods of time with the arm extended to the side, leakage may occur through the tractor's spool valve – this can be rectified by lowering the flailhead to the ground, moving the external service lever to float before returning it to the centre position and resuming work.

IMPORTANT – The Axle Locking System must only be activated or used whilst the machine is in normal work mode. NEVER lock the axles of the tractor during transportation or whilst manoeuvring the unit.

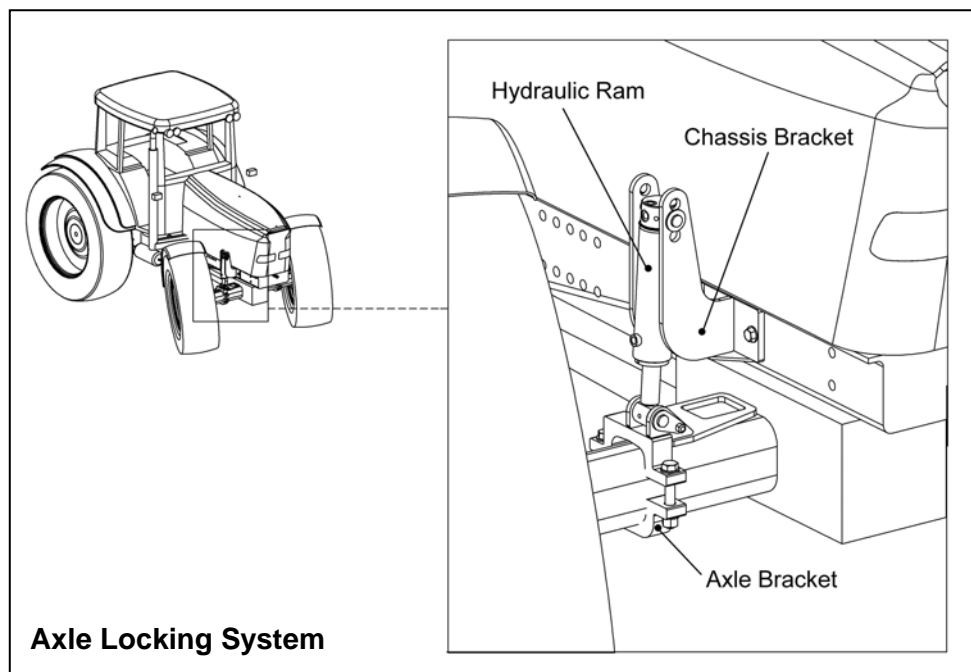

VEHICLE/ TRACTOR PREPARATION

We recommend vehicles be fitted with cabs using safety glass windows and protective guarding when used with our machines.

Fit Operator Guard (part no. 73 13 324) using the hooks provided. Shape mesh to cover all vulnerable areas.

Remember the driver must be looking through mesh and/or polycarbonate glazing when viewing the flail head in any working

position - unless the vehicle/ cab manufacturer can demonstrate that the penetration resistance is equivalent to, or higher than, that provided by mesh/polycarbonate glazing. If the tractor has a roll bar only, a frame must be made to carry both mesh and polycarbonate glazing. The operator should also use personal protective equipment to reduce the risk of serious injury such as; eye protection (mesh visor to EN1731 or safety glasses to EN166), hearing protection to EN352, safety helmet to EN297, gloves, filter mask and high visibility clothing.

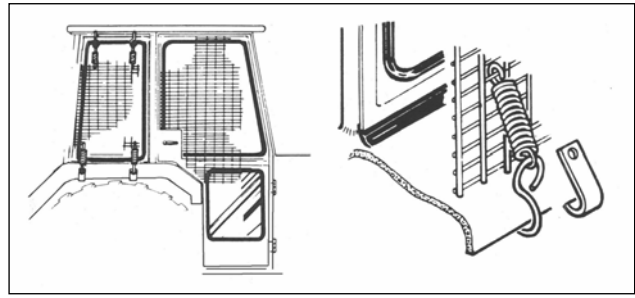

Vehicle Ballast: It is imperative when attaching 'third-party' equipment to a vehicle that the maximum possible stability of the machine and vehicle combination is achieved – this can be accomplished by the utilisation of 'ballast' in order to counter-balance the additional equipment added.

Front weights may be required for rear mounted machines to place 15% of total outfit weight on the front axle for stable transport on the road and to reduce 'crabbing' due to the drag of the cutting unit when working on the ground.

Rear weights may be required to maintain a reasonable amount of rear axle load on the opposite wheel from the arms when in work; for normal off-ground work i.e. hedge cutting this should be 20% of rear axle weight or more for adequate control, and for ground work i.e. verge mowing with experienced operators, this can be reduced to 10%.

All factors must be addressed in order to match the type and nature of the equipment added to the circumstances under which it will be used – in the instance of Power Arm Hedgecutters it must be remembered that the machines centre of gravity during work will be constantly moving and will differ from that during transport mode, therefore balance becomes critical.

Factors that effect stability:

- *Centre of gravity of the tractor/machine combination.*
- *Geometric conditions, e.g. position of the cutting head and ballast.*
- *Weight, track width and wheelbase of the tractor.*
- *Acceleration, braking, turning and the relative position of the cutting head during these operations.*
- *Ground conditions, e.g. slope, grip, load capability of the soil/surface.*
- *Rigidity of implement mounting.*

Suggestions to increase stability:

- *Increasing rear wheel track; a vehicle with a wider wheel track is more stable.*
- *Ballasting the wheel; it is preferable to use external weights but liquid can be added to around 75% of the tyre volume – water with anti-freeze or the heavier Calcium Chloride alternative can be used.*
- *Addition of weights – care should be taken in selecting the location of the weights to ensure they are added to a position that offers the greatest advantage.*
- *Front axle locking, check with tractor manufacturer.*

The advice above is offered as a guide for stability only and is not a guide to vehicle strength. It is therefore recommended that you consult your vehicle manufacturer or local dealer to obtain specific advice on this subject, additionally advice should be sought from a tyre specialist with regard to tyre pressures and ratings suitable for the type and nature of the machine you intend to fit.

REAR TANK FRAME ATTACHMENT

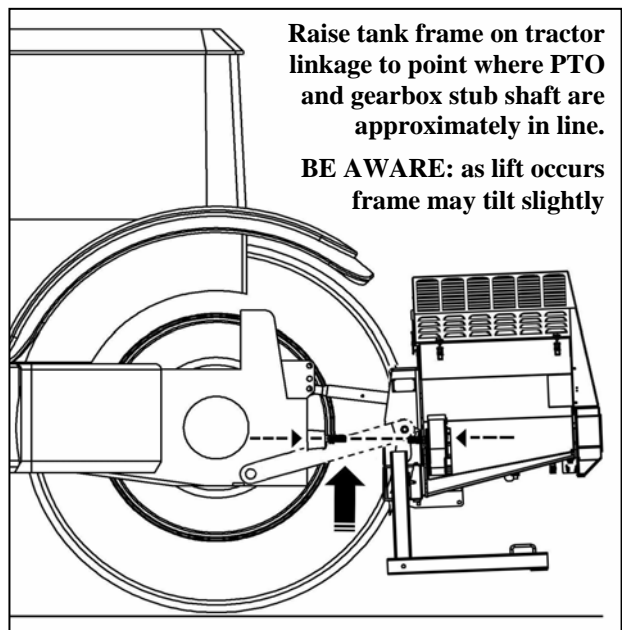
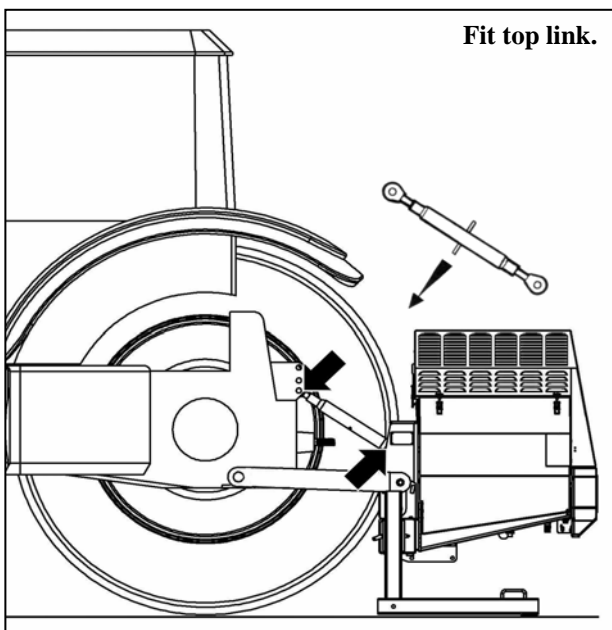
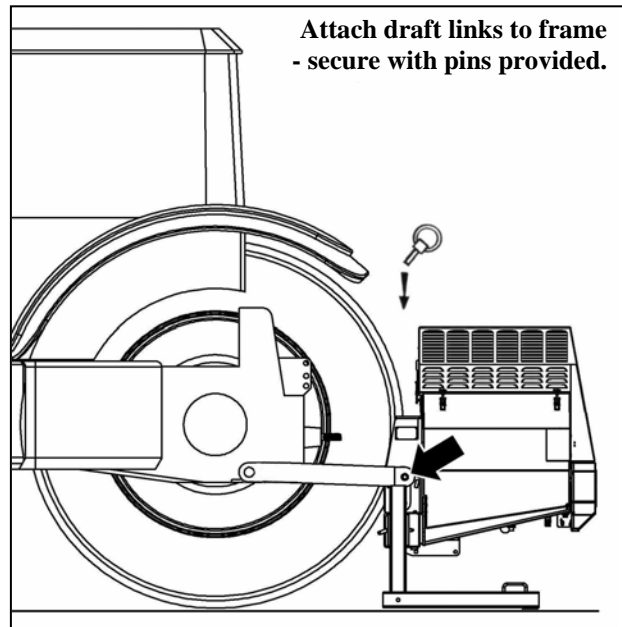
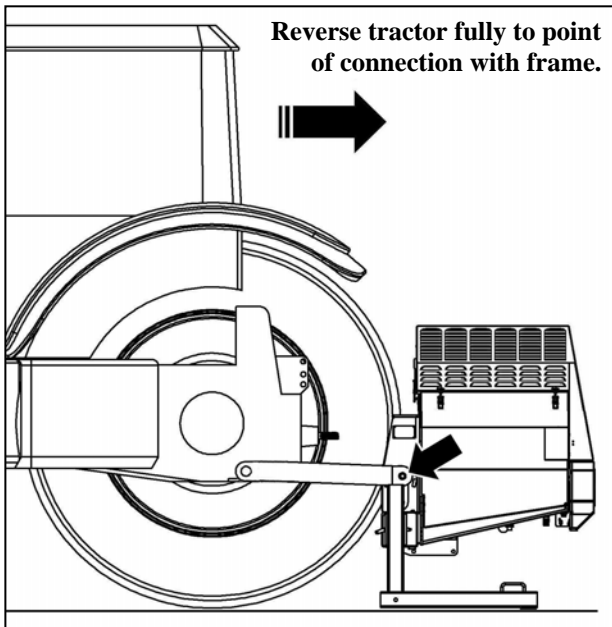
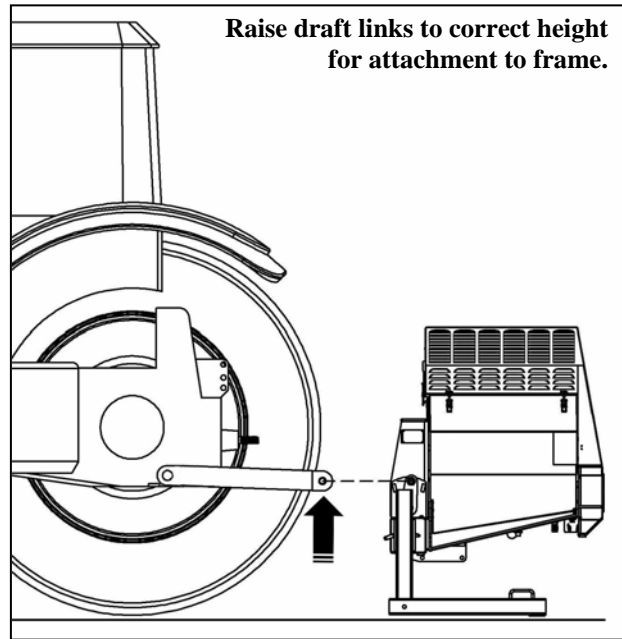
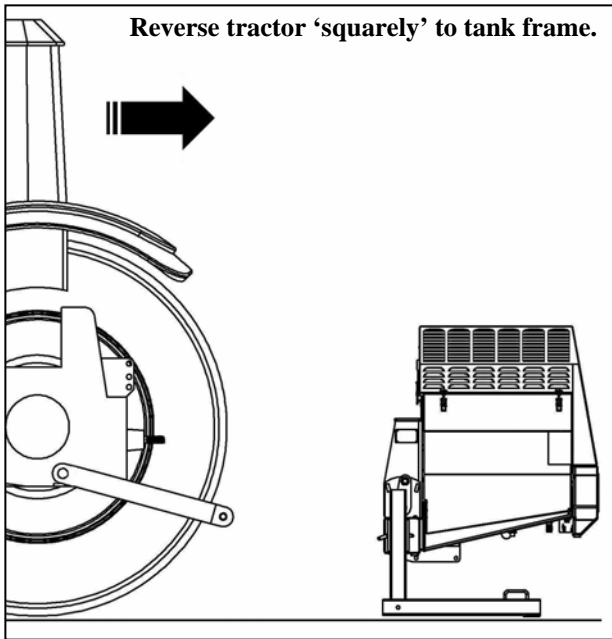

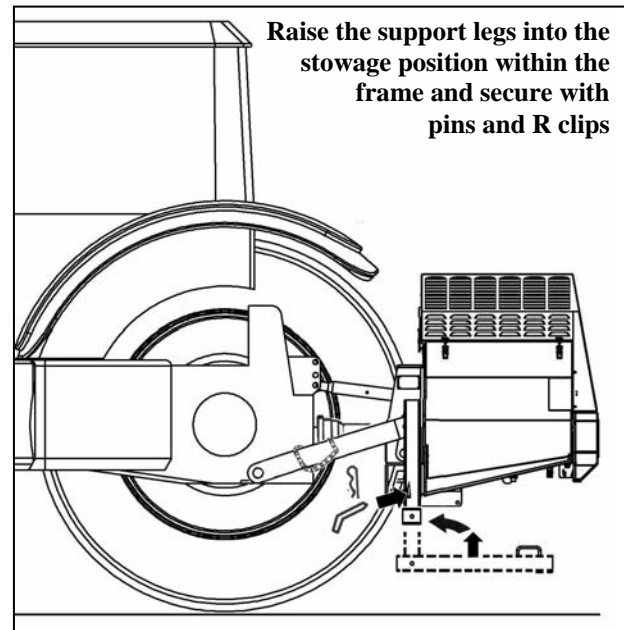
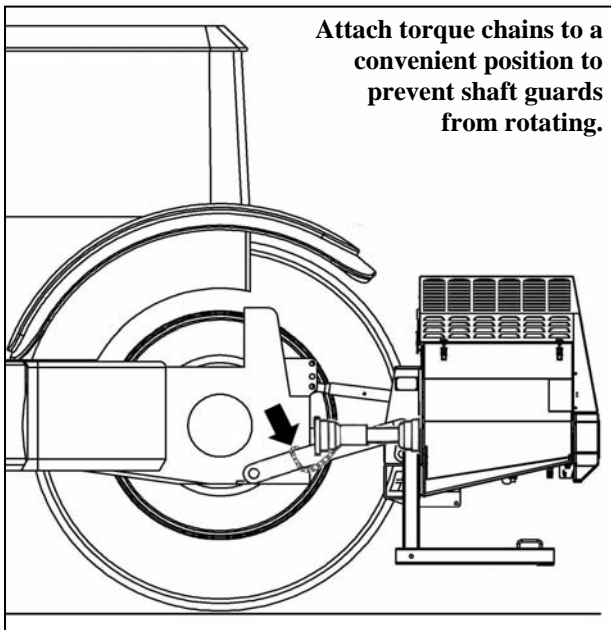
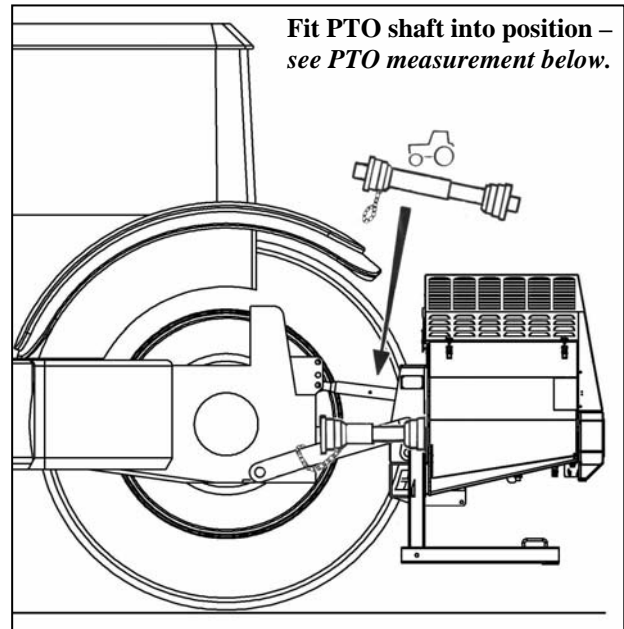
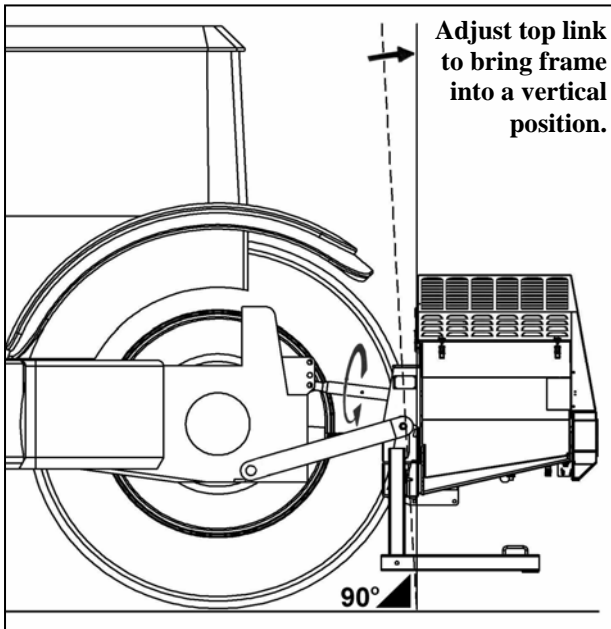

PTO Measurement

Measure distance 'A' shown in illustration opposite – cut PTO to measurement 'A' minus 75mm (3").

Note - for subsequent use on a different tractor measure again – there must always be a minimum shaft overlap 150mm.

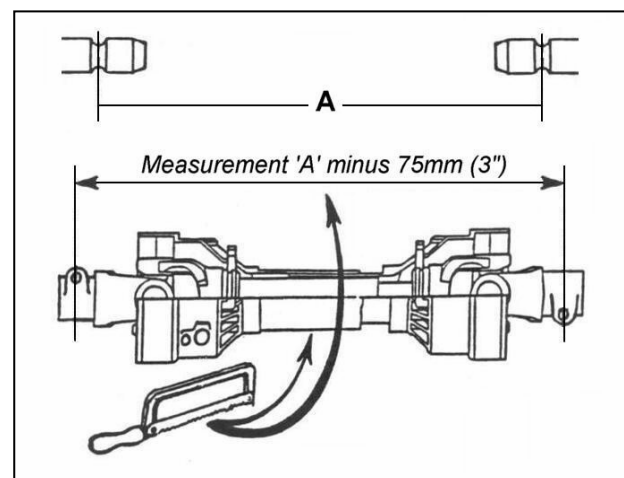

Rear Tank Frame Removal

Removal of the rear tank frame is a reversal of the above procedure.

DETACHING THE ARM UNIT

Support & Storage Frame

Removal of the Mid-Mount arm unit necessitates the use of a purpose-built support and storage frame that ensures the unit is safely and securely supported throughout the removal process and during it's storage – NEVER attempt to remove or store the arm unit without the use of this frame.

The illustrations below show the support frame and arm unit attachment locations – 'A' to 'D' are 'fixing' points and 'E' is a 'resting' point.

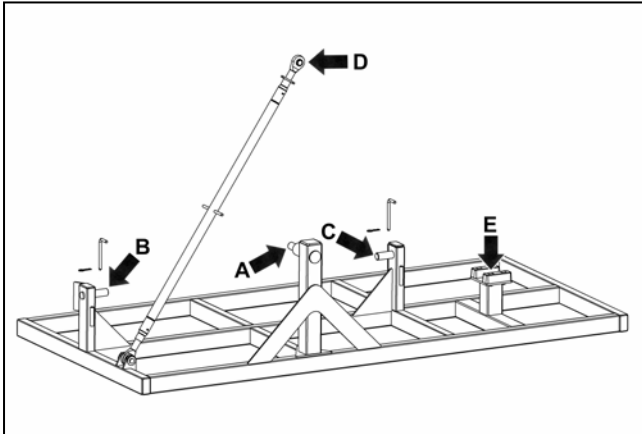

Support Frame showing attachment points

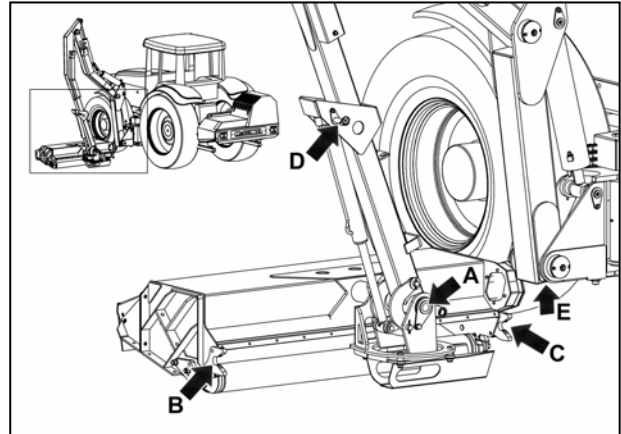

Arm Unit to Support Frame attachment points

Attaching Arm Unit to Support and Storage Frame

It is vital during attachment or detachment of the arm unit to the support frame that both the tractor and frame are sited on firm level ground.

With the machines arms positioned at right angles to the tractor reverse the unit into a position alongside and slightly ahead of the support frame - ensure that the distance between tractor and frame is sufficient to allow the tractor to be driven away freely without fouling the arm unit once it has been removed.

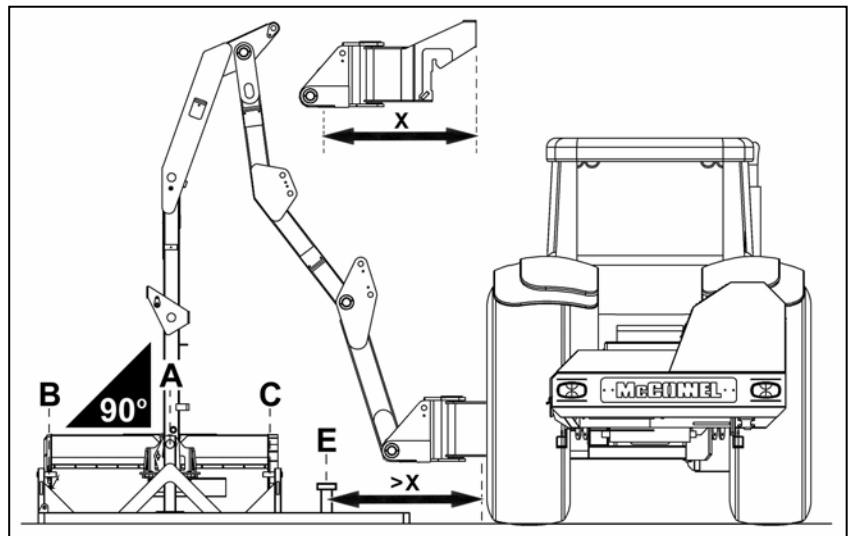

Angle the arms and flailhead to a position where, with the dipper arm vertical and the flailhead parallel to the ground, the attachment points 'A', 'B' & 'C' on the machine are lined up with their respective connection points on the support frame.

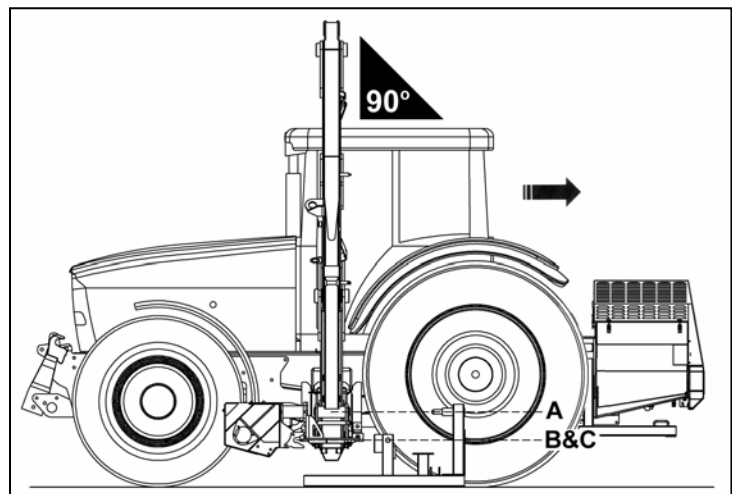

Reverse tractor slowly until all attachment points locate and connect fully.

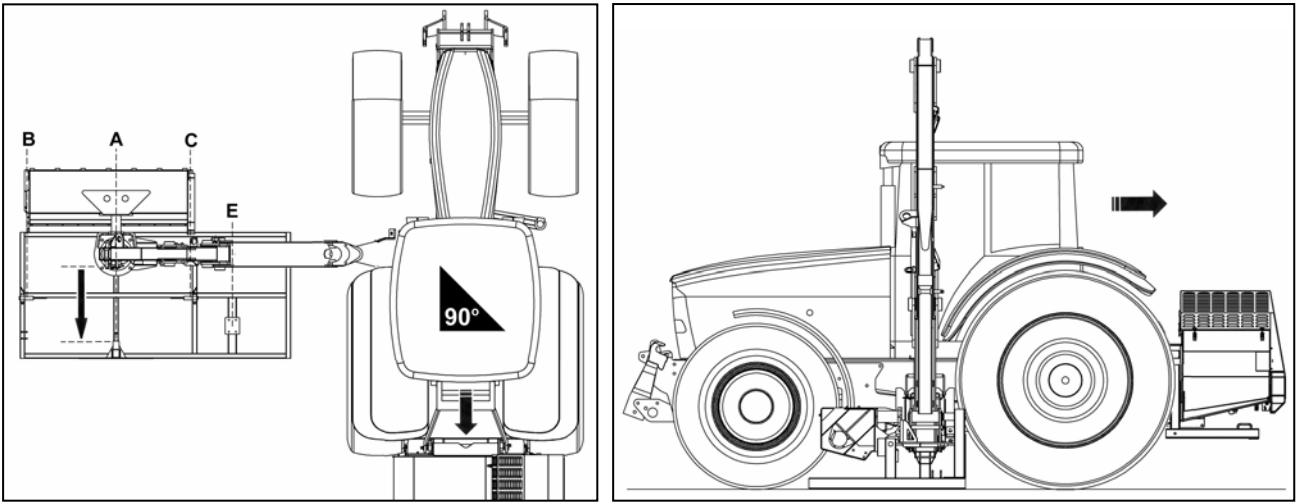

Secure points 'B' and 'C' using locking pins and R-Clips provided then connect and tighten the angle brace supplied from the frame to point 'D' on the machines dipper arm – see *diagram opposite*.

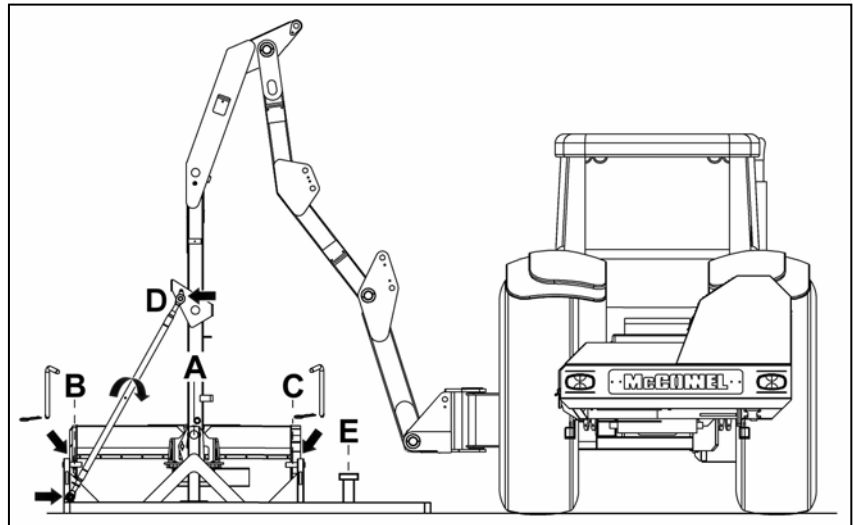

Detaching the Arm Unit

Loosen and remove the two bolts, nuts and washers that secure the lower part of the intermediate frame to the tractor subframe – refer to *diagram opposite*.

The arm unit is now ready to be detached from the tractor by utilisation of the machines hydraulic rams – *great care should be adopted when carrying out this procedure ensuring that bystanders are kept at a safe distance*.

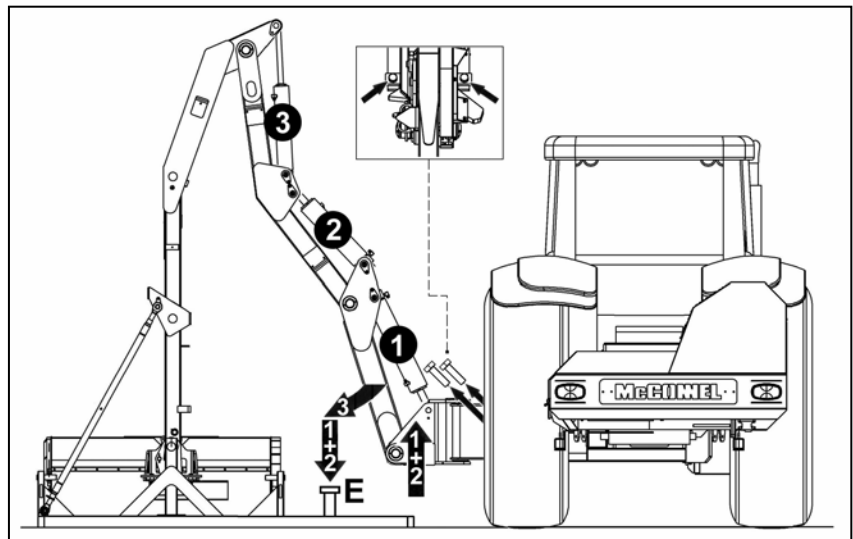

As the upper part of the intermediate frame hooks over the top of the subframe the intermediate frame will need to be raised before arm unit is free to be detached - this is done by operation of the 1st and 2nd rams of the machine – Note: only raise the unit to a height sufficient to allow it to be manoeuvred clear of the subframe – if it is raised too high it will risk fouling on the tractor components above.

Once the unit is clear of the subframe the machine's arms can then be folded into the support frame by operation of the 3rd ram, and with subsequent use of the 1st and 2nd rams positioned and placed onto its support cradle 'E' – indicated in the diagrams.

Once the arm unit has been correctly parked on the support frame the hydraulic hoses should then be disconnected from the quick release couplings mounted on the bulkhead of the rear tank frame and carefully withdrawn from their routing location. Stow hose lines neatly, clear of the ground and away from risk of accidental damage.

Re-attachment of Arm Unit

Re-attachment of the arm unit to the tractor is a reversal of the removal procedure – *as with all tasks of this nature safety and caution at all times should be of primary importance to avoid risk of personal injury or damage to machinery.*

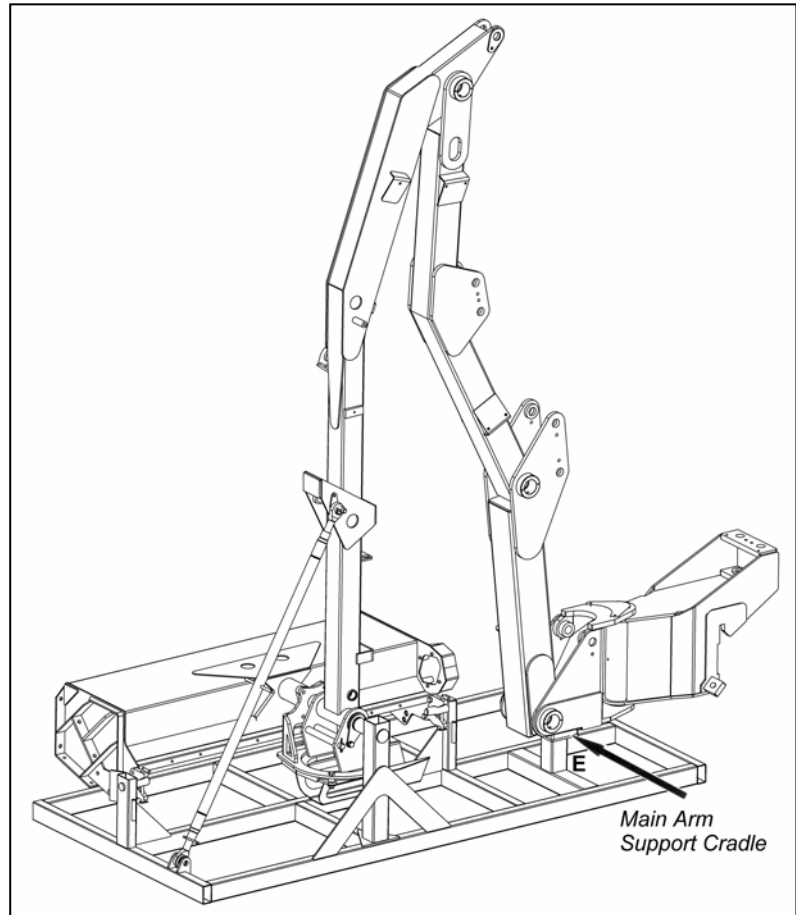

Arm Unit correctly positioned on Support Frame

OIL REQUIREMENTS

Hydraulic Tank

Fill the reservoir to approximately 50mm (2") below the top of the tank - **do not overfill**.
The capacity is approximately 240 Litres

Recommended Oil

Supplier	Cold or Temperate Climate	Hot Climate
BP	<i>Bartran 46</i> <i>Energol HLP-HM 46</i>	<i>Bartran 68</i> <i>Energol HLP-HM 68</i>
CASTROL	<i>Hyspin AWH-M 46</i>	<i>Hyspin AWH-M 68</i>
COMMA	<i>Hydraulic Oil LIC 15</i>	<i>Hydraulic Oil LIC 20</i>
ELF	<i>Hydrelf HV 46</i> <i>Hydrelf XV 46</i>	<i>Hydrelf HV 68</i>
ESSO	<i>Univis N 46</i>	<i>Univis N 68</i>
FUCHS (UK/Non UK markets*)	<i>Renolin 46</i> <i>Renolin HVZ 46</i> <i>Renolin CL46/B15*</i> <i>Renolin AF46/ZAF46B*</i>	<i>Renolin 68</i> <i>Renolin HVZ 68</i> <i>Renolin CL68/B20*</i> <i>Renolin AF68/ZAF68B*</i>
GREENWAY	<i>Excelpower HY 68</i>	<i>Excelpower HY 68</i>
MILLERS	<i>Millmax 46</i> <i>Millmax HV 46</i>	<i>Millmax 68</i> <i>Millmax HV 68</i>
MORRIS	<i>Liquimatic 5</i> <i>Liquimatic HV 46</i> <i>Triad 46</i>	<i>Liquimatic 6</i> <i>Liquimatic HV 68</i> <i>Triad 68</i>
SHELL	<i>Tellus 46</i> <i>Tellus T46</i>	<i>Tellus 68</i> <i>Tellus T68</i>
TEXACO	<i>RandoHD 46</i> <i>Rando HDZ 46</i>	<i>Rando HD 68</i> <i>Rando HDZ 68</i>
TOTAL	<i>Equivis ZS 46</i>	<i>Equivis ZS 68</i>

FITTING CONTROL UNIT IN CAB

A mounting pillar/bracket is supplied onto which the control unit is fitted. The pillar/bracket should be attached to the tractor ensuring that no structural component of the cab or roll bar is drilled – it should be located in a suitable, comfortable, working position.

The supply cable should be connected directly to the tractor's battery or to any 30 amp electrical output provided by the tractor manufacturer. Avoid using cigarette lighter type connections as these may prove to be sporadic and unreliable for control applications. The control is 12 volt D.C. operated; The Red lead is Positive and the Blue lead is Negative.

PRE-OPERATIONAL CHECKS

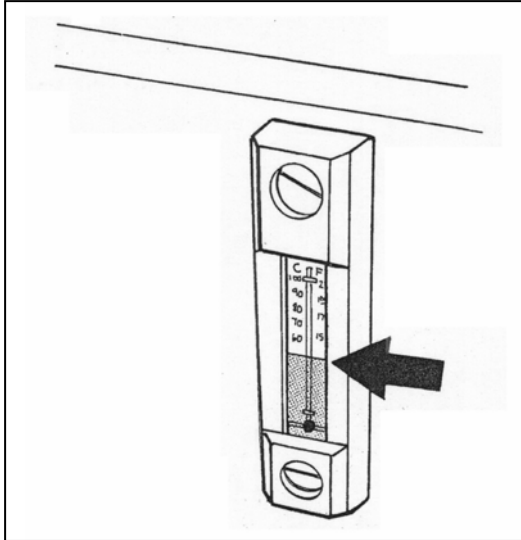

CHECK: Oil level in Hydraulic Tank.

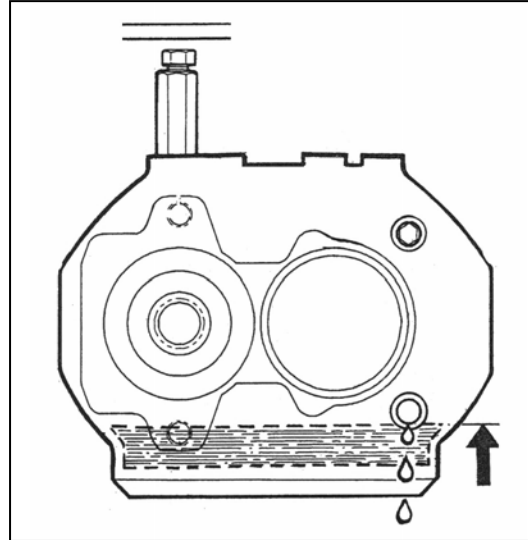

CHECK: Oil level in Gearbox.

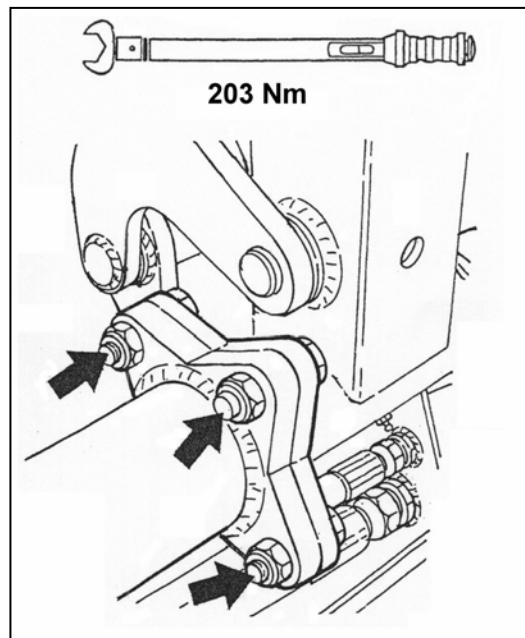

CHECK: All bolts are tight and that those in the specific locations indicated above are torqued to the figure stated.

RUNNING UP PROCEDURE

Ensure that the rotor control valve is in "STOP" position, start tractor, engage PTO allow the oil to circulate through the return line filter for about 5 minutes without operation of the armhead control lever.

Operate the armhead levers through their complete range ensuring that all movements are functioning correctly.

Place the flail head at a safe attitude and move the rotor control to "START" position. After initial fluctuation, the rotor should settle to a steady speed. Increase PTO speed to approximately 650 rpm and run for a further five minutes before disengaging and stopping tractor.

Check the hose runs and ensure that they are free from any pinching, chaffing, straining or kinks. Re-check the oil level in the tank-and top up as necessary.

OPERATION

Operator Guard

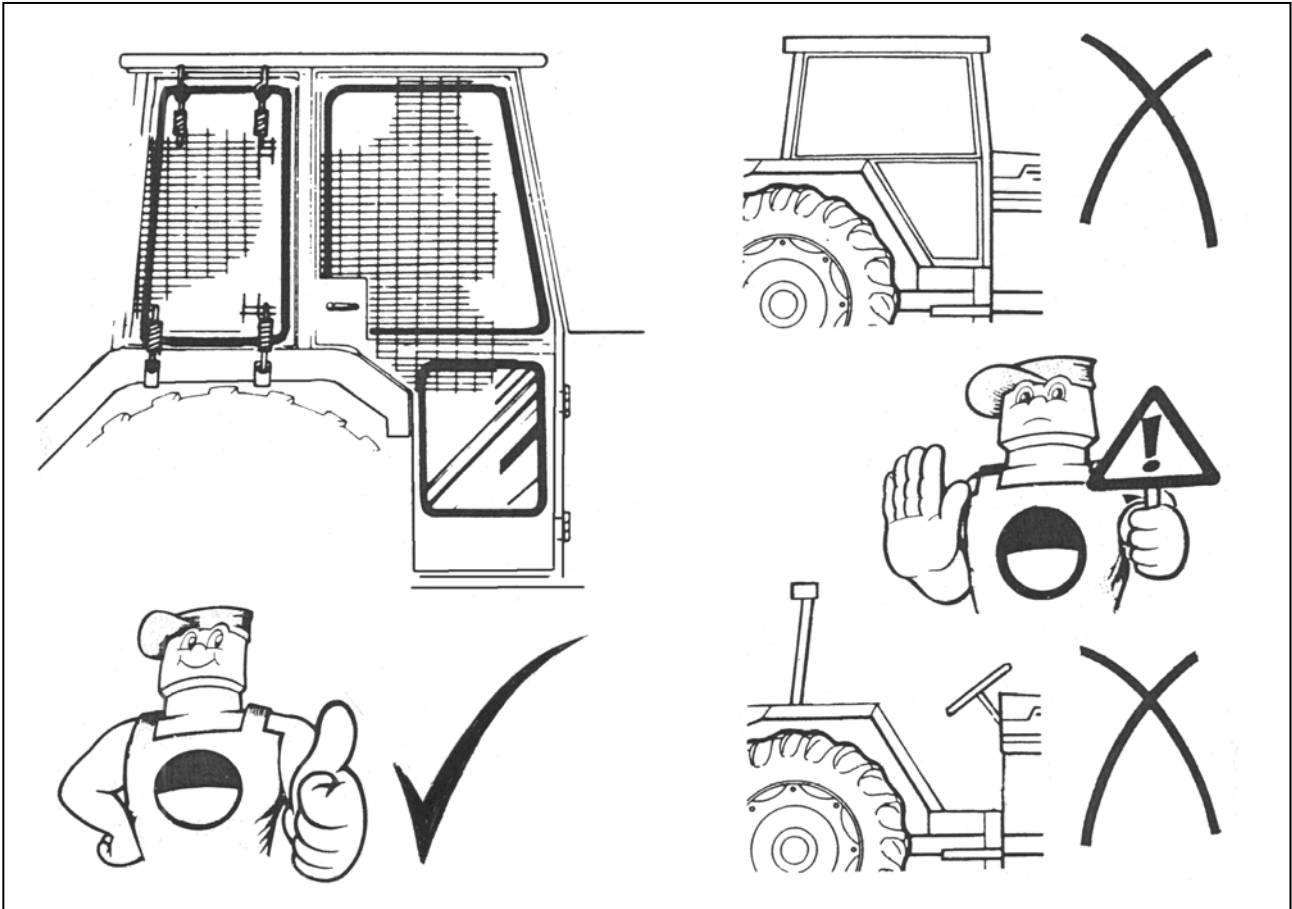

Machine Guards

Before each period of work, check that all the relevant tractor and machine guards are in place and in good working condition.

Small splits and abrasions on the lower edges of the flail head rubber flaps are permissible, but should one or more of these cuts or splits become fifty per cent or more of the flap height they should be replaced immediately as they will have become ineffective for debris containment.

Operator Safety

During operation all the tractor windows should be kept firmly closed with the exception of the rear window which may be opened only to the extent that is sufficient to allow entry of electrical or operating cables for the machine into the cab.

Should the tractor not be fitted with a 'quiet' cab ear defenders must be worn at all times, failure to heed this warning may result in permanent damage to hearing.

Although in normal circumstances a working machine or rotating parts should never be approached it is an additional wise precaution to avoid wearing loose or flapping clothes especially scarves and neckties whilst in close proximity to a machine.

The operator should continually guard himself and others from complacency that can arise from familiarity. Never attempt to take 'short cuts', always follow the correct procedures diligently and abide by the restrictions imposed by safety considerations.

REMEMBER: there is only one right way - the safe way!

PREPARATION

READ THE BOOK FIRST

Practice operating the machine in an open space **without the rotor running** until you are fully familiar with all the controls and the operation of the machine.

CAUTION

Care must be taken when working with the flail head close in as it can come into contact with the tractor.

Running In a New Machine

For the first days work it is recommended that tractor forward speed is restricted to 3 km/hr maximum - this will allow machine components to 'bed in' and allow the operator to become familiar with the controls and their response under working conditions whilst operating at a relatively slow speed. If possible, select a first days work that will provide a majority of light to average cutting with only occasional heavy duty work - *during this period check that nuts and bolts are tight after: one hour, four hours and again at the end of the day.*

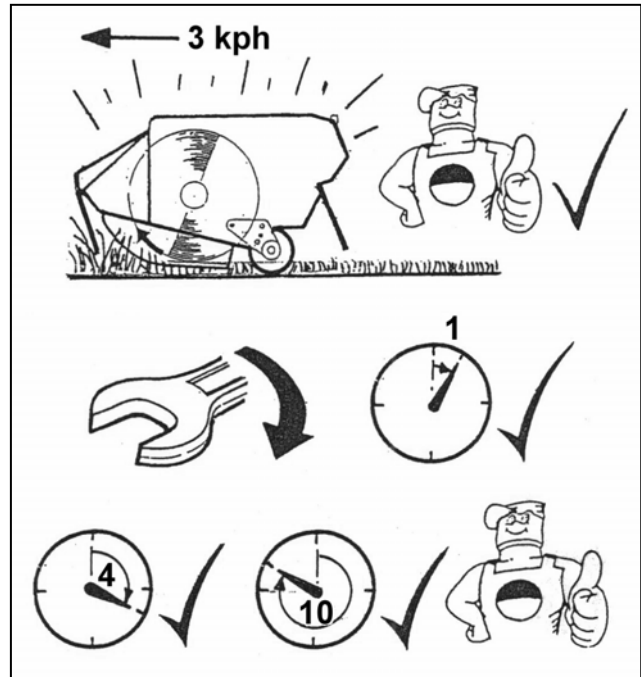

Cutting Precautions

Inspect the work area, remove any hazardous materials and note any immovable objects - *it may also be a wise precaution to indicate these hazards with a visible marker than can be easily seen from the tractors operating position.*

If the type of work being undertaken makes this important precaution impractical, always maintain a high degree of alertness and observation and restrict the tractors forward motion to a speed that will allow the operator sufficient time to stop the tractor before contact is made with the hazard.

General Working Practices

It is the operator's responsibility to develop safe working procedures;

ALWAYS:

- Be aware of hazards in the vicinity.
- Ensure all guards are in position and in good condition.
- Disengage PTO before stopping the engine.
- Wait until the flail has stopped running before leaving the tractor seat.
- Disengage the PTO, stop the engine and pocket the key before making any adjustments.
- Check frequently that all nuts and bolts are tight.
- Keep bystanders at a safe distance.

PROPORTIONAL ARMREST CONTROL – Button Functions

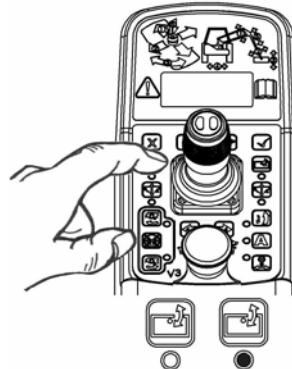
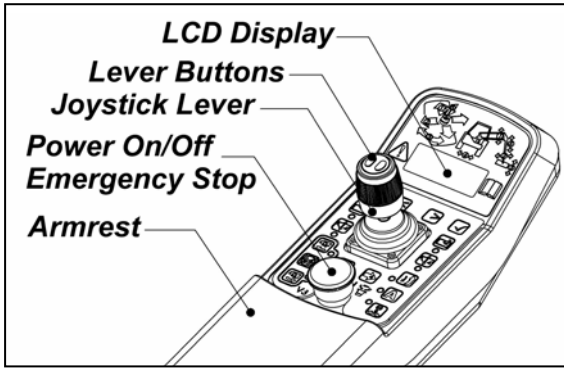

Head Angle Float

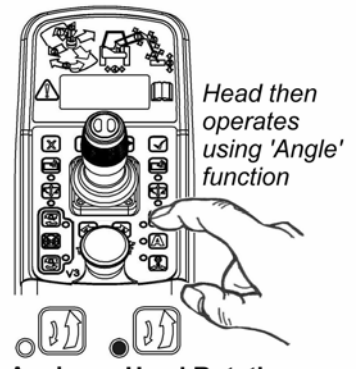

Angle Activated Head Rotation Activated

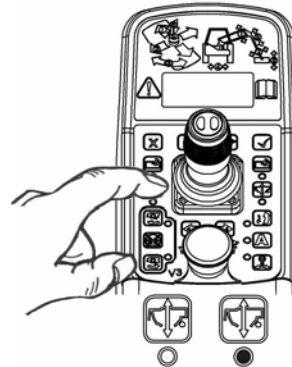
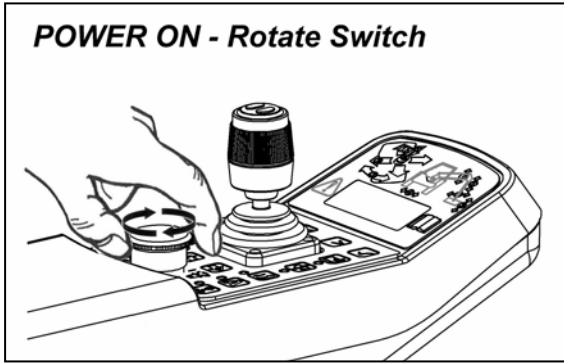

Lift Float

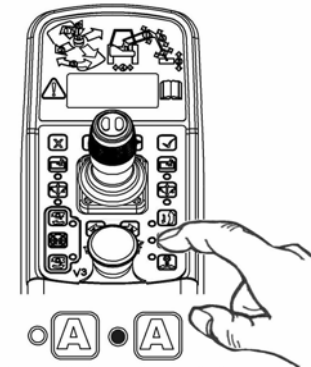

Joystick Active Joystick Disabled

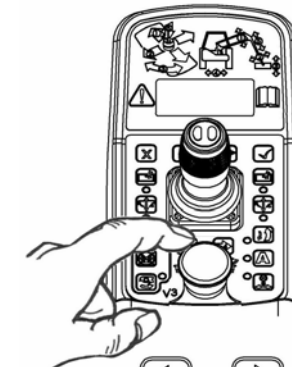
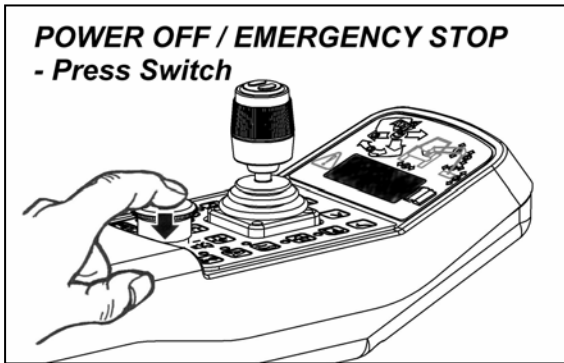

Slew ← →

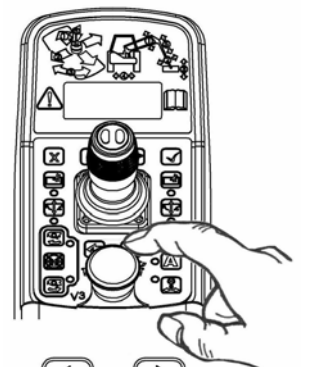

← → Slew



Rotor Uphill



Rotor OFF

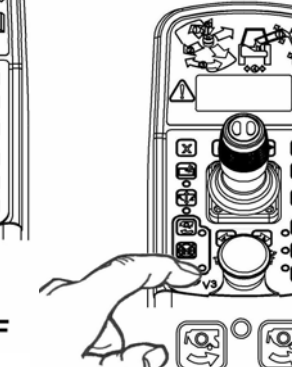

Rotor Downhill

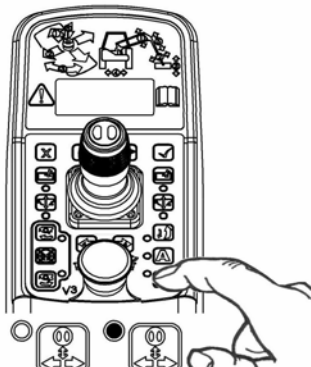

Mode Swap

FEATURE STATUS (Indicated by L.E.D.)

- Deactivated
- Activated

PROPORTIONAL CONTROLS – Arm Operation

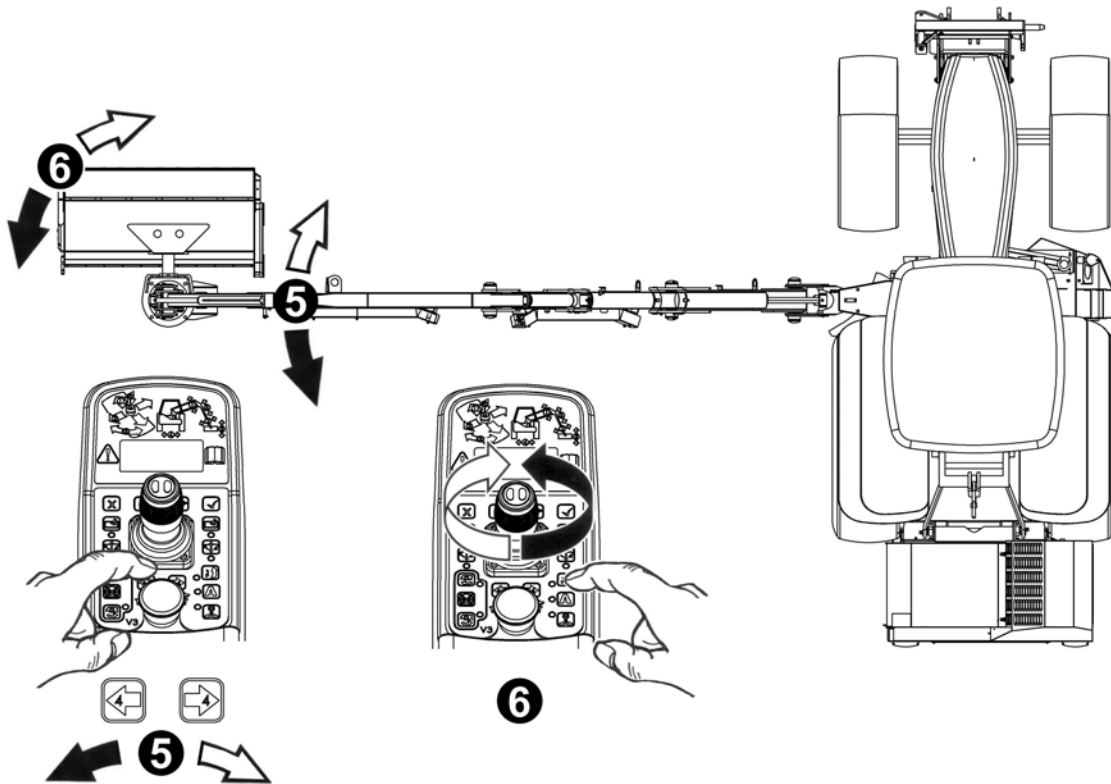
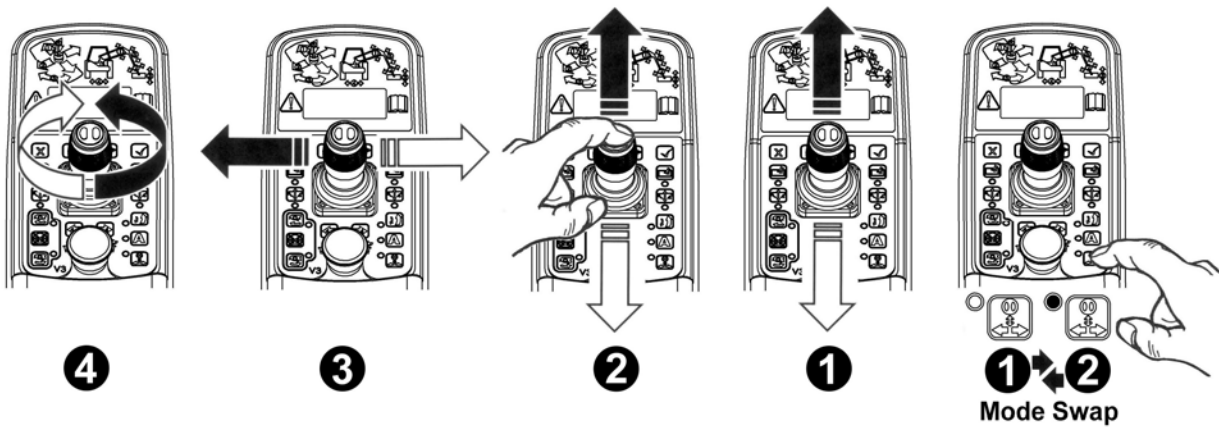
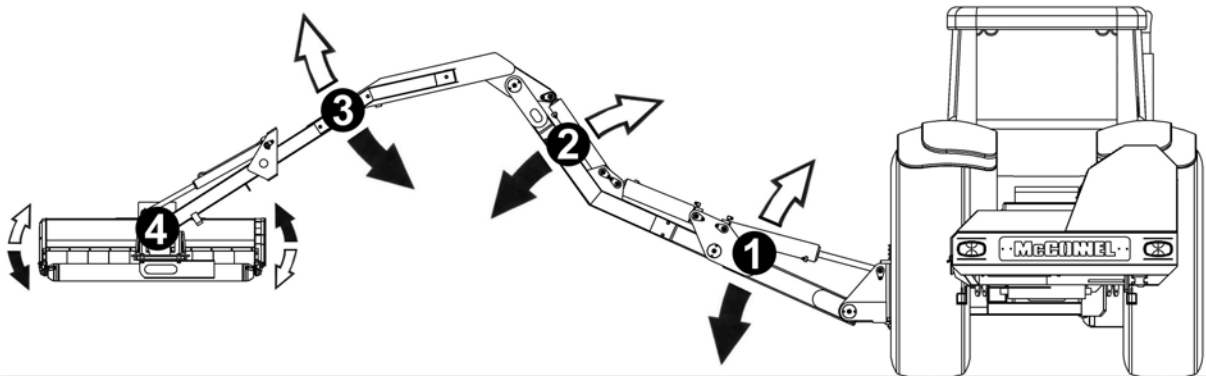

PROPORTIONAL CONTROLS – Screen & Menu Access Buttons

The selection and monitoring of flailhead and rotor features is achieved via the built in LCD screen on the v3 Proportional Control unit. Through a series of 'on-screen menus' the operator can select and monitor certain functions – the four 'touch pad' buttons directly below the screen allow the operator to 'scroll' through and access the menus to select the features - *the diagrams opposite and below show the location of the screen and access buttons on the control unit and their function.*

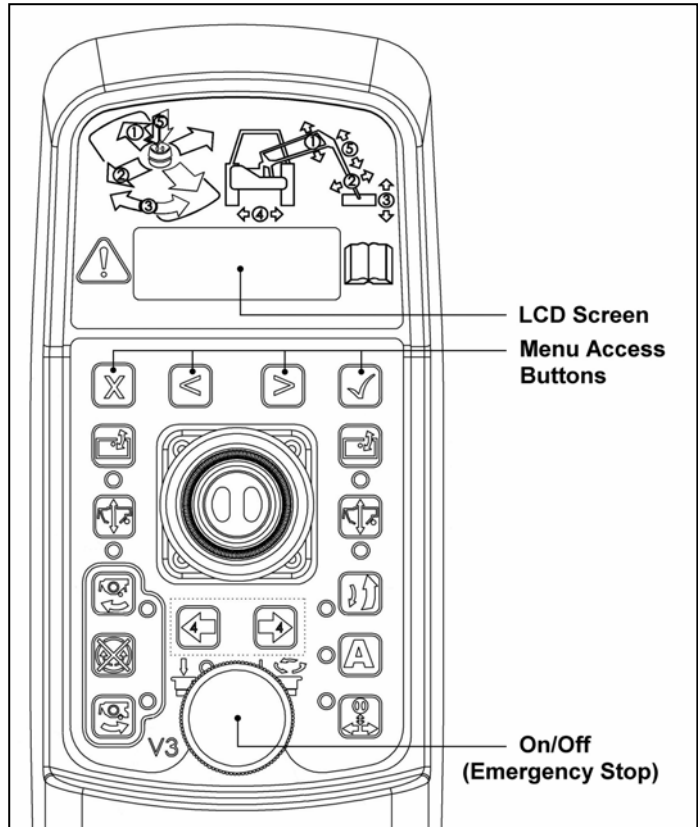

LCD Screen Access & Command Buttons

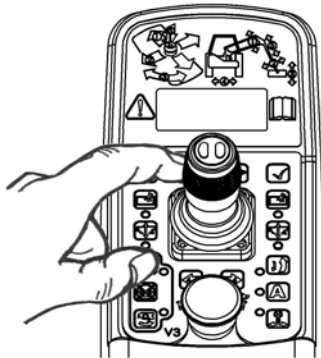

Scroll Back

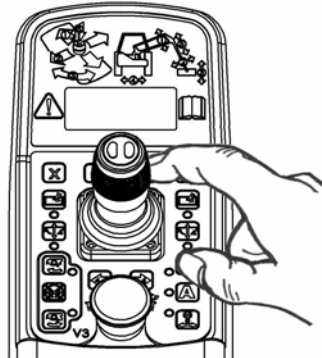

Scroll Forward



Decline Command



Accept Command

PROPORTIONAL CONTROLS – Screen Display & Functions

The Proportional Control Unit is switched on by rotation of the ON/OFF button, at which point the LCD screen will light up – *Note: 12 volts at the battery are required for this unit to function correctly.*

1. On powering up of the unit the initial display will show 'McCONNEL', software version, and PTO maximum speed.



2. Pressing scroll forward once will display the running screen. The **TOT** displays the total time the rotor has been switched on. The **JOB** also displays the rotor on time but may be reset to zero by pressing the **X** button for 3 seconds.



3. Pressing either of the Rotor ON buttons will activate the 'egg timer' and rotor image.



4. Pressing the EDS Lift float button will turn on the EDS (EDS Lift Float machines only). Then **SOFT**, **MED** or **HARD** will be added to the running screen.

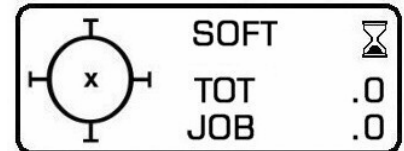

5. Pressing ✓ while the EDS is turned on will scroll through the **SOFT**, **MED** and **HARD** working settings.



6. Pressing scroll forward displays the actual Tractor PTO running speed.

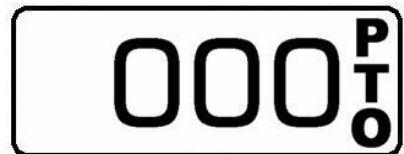

7. Scrolling forward again displays the Power Monitor screen.



Scrolling backwards will display the screens in the opposite order.

V4 PROPORTIONAL CONTROLS - Buttons & Thumbwheels Operation



NOTE: By default operation of thumbwheels T1 and T2 in conjunction with button B1 activates Head Angle Float and EDS/Lift Float respectively. These controls can, if required, be swapped over so that the thumbwheels operate the opposing functions – this procedure is performed by accessing the settings menu on the control unit via the screen and menu buttons.

FLOAT SELECTION & DE-SELECTION

Operate thumbwheels to their furthest points (+ or -) to select or deselect float functions.

FLOAT ACTIVATION

Hold button B1 in conjunction with Thumbwheel T1 or T2 operation to activate required float mode - thumbwheels must be rotated to their furthest point to select or de-select the feature

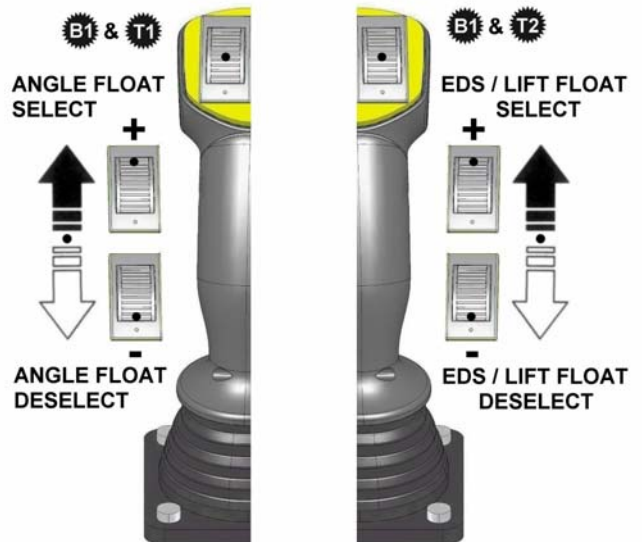

ANGLE & SLEW OPERATION

Rotate thumbwheels in required direction.

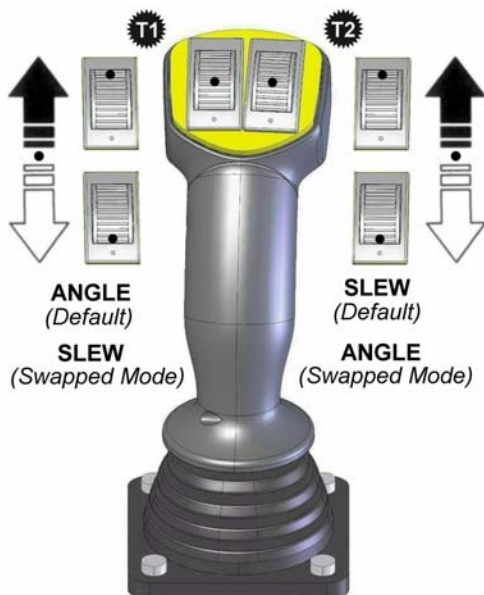

DIVERTER VALVE SELECTION

Diverter selection is via button B2

DIVERTER VALVES

Press once to activate DV #1
Press & hold to activate DV #2
(de-activated on release of button)



ARMHEAD OPERATION – V4 JOYSTICK CONTROLS

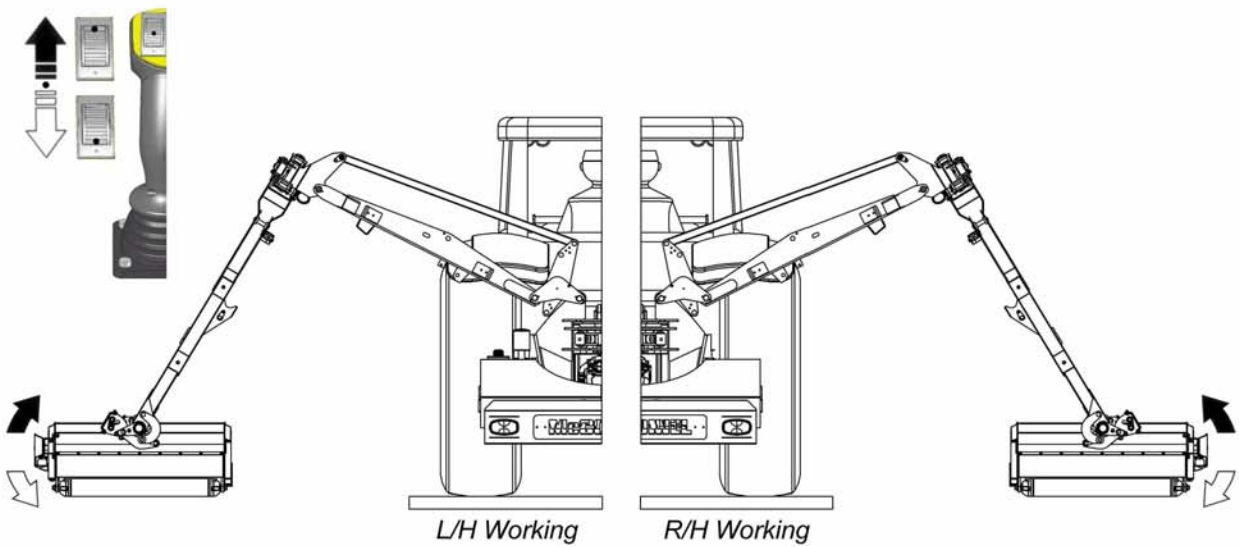
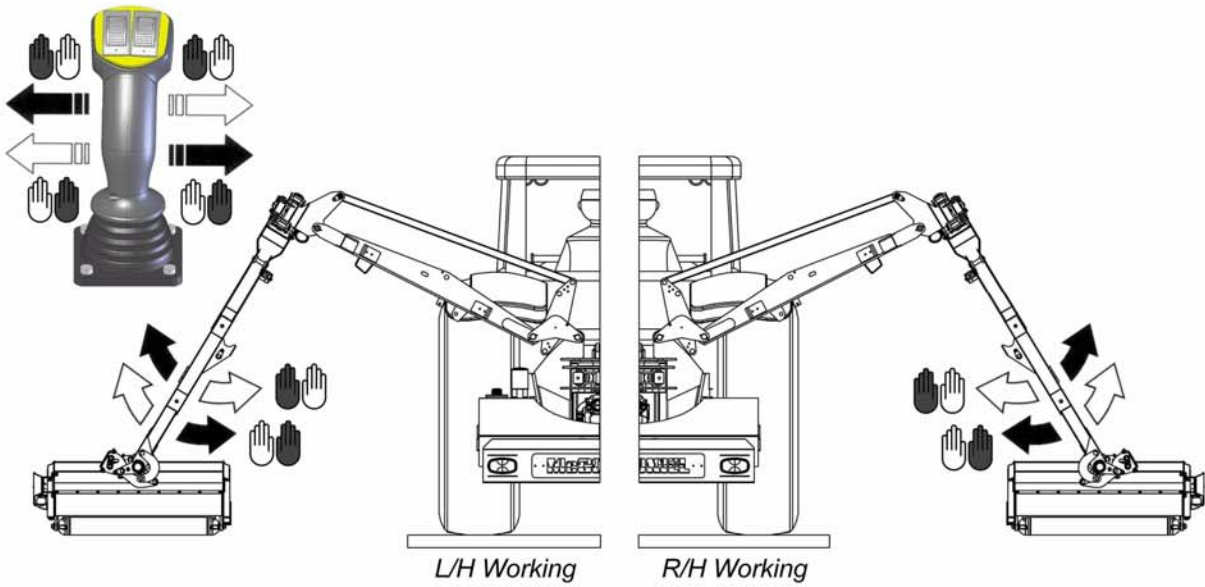
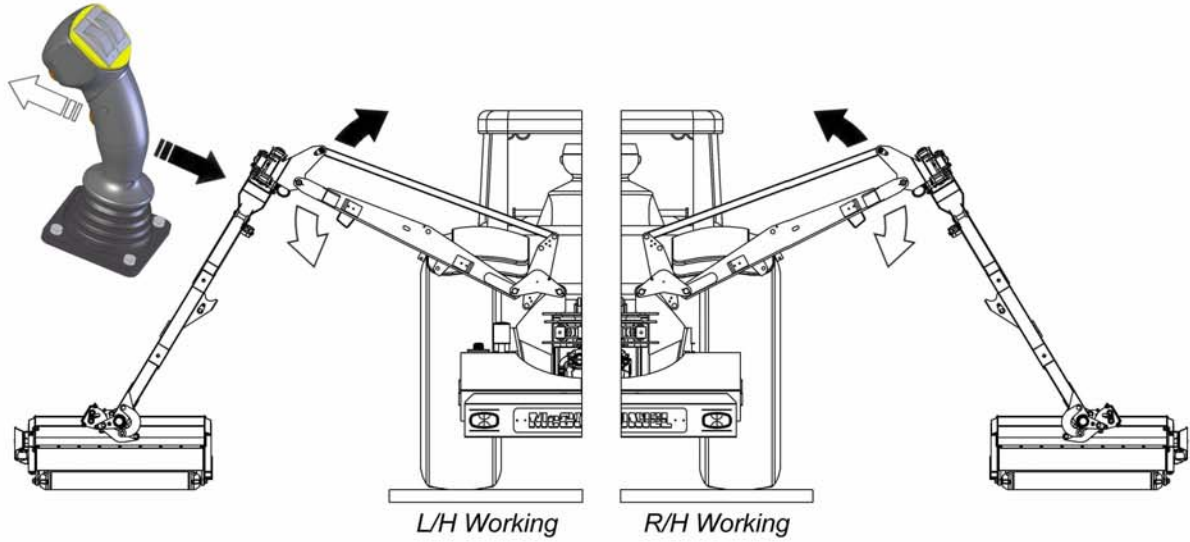

NOTE: Illustration shows the left hand thumbwheel as the default angle control, this can be swapped within the settings to the right hand thumbwheel if desired.

MIDCUT OPERATION – V4 JOYSTICK CONTROLS (Diverted Mode)



Activate Diverter Valve #1 - Midcut Arm is then operated using the right hand thumbwheel.

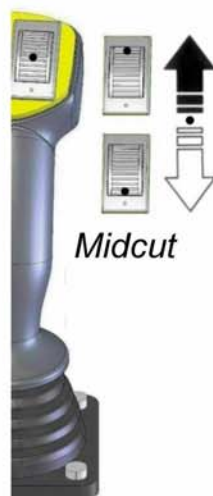
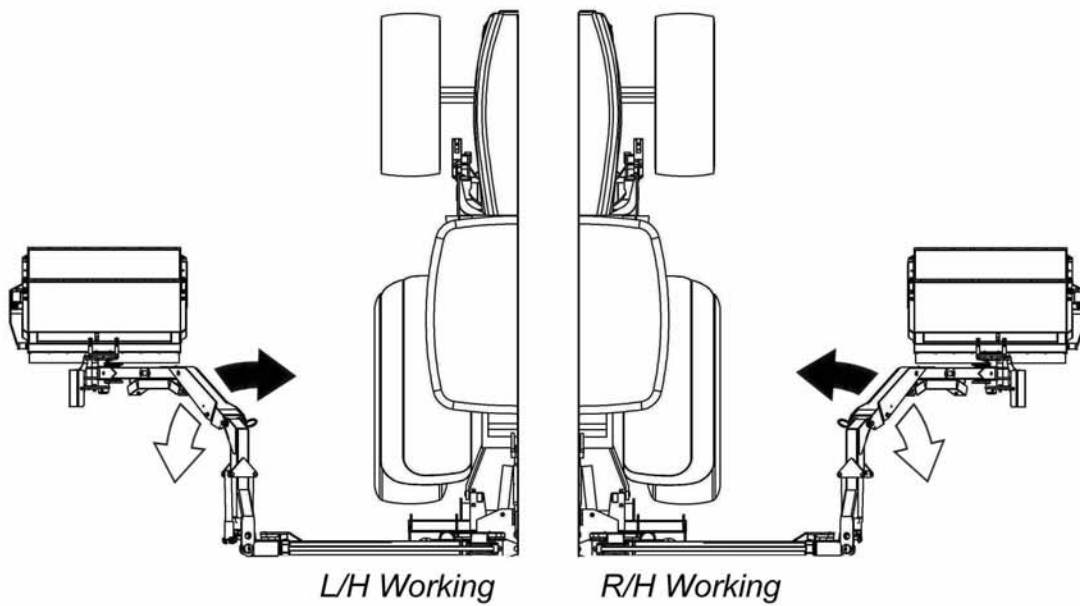

V4 PROPORTIONAL CONTROL BOX

POWER ON / OFF (Emergency Stop)

Rotate Clockwise to Power On – control unit will emit a single beep and screen will display the selected PTO speed, software version and the McConnell name. Press to Power Off.

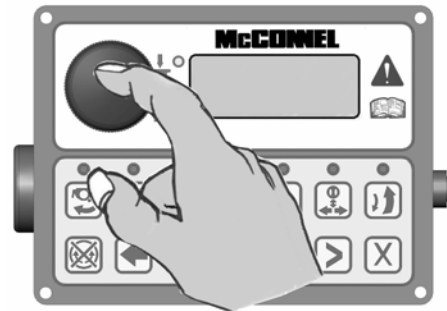
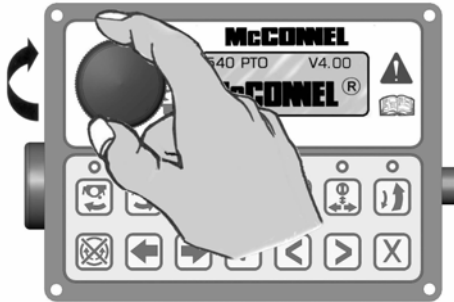

ROTOR START – Uphill Cutting

This button starts the rotor for 'uphill' cutting – when the button is pressed the control unit will emit a single beep, the LED light will illuminate and the screen will momentarily display 'FLAIL START ✓'.

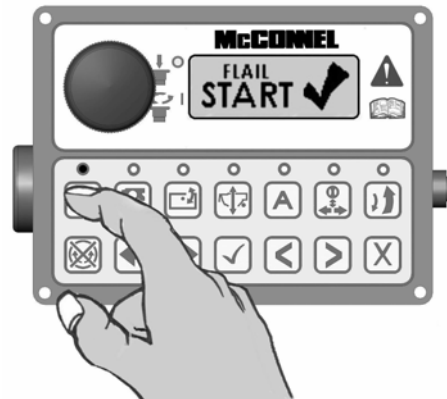

ROTOR START – Downhill Cutting

This button starts the rotor for 'downhill' cutting – when the button is pressed the control unit will emit a single beep, the LED light will illuminate and the screen will momentarily display 'FLAIL START ✓'.

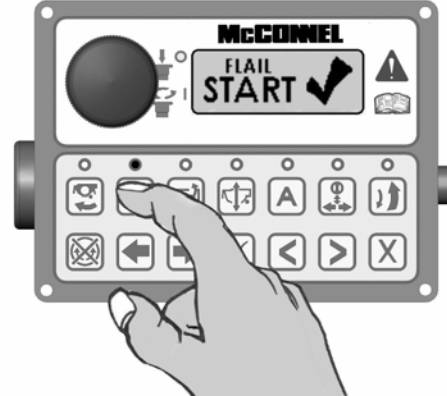

ROTOR STOP

This button stops the rotor – when the button is pressed the control unit will emit a single beep and the screen will momentarily display 'FLAIL STOP ✓' – the LED lights above both rotor start buttons will be illuminated for approximately 10 seconds, during this period the rotor start buttons will be disabled to allow sufficient time for the rotor to power down. When the LED lights go out the rotor direction can be changed or the rotor allowed to stop.



WARNING: The LED lights going out do not indicate that the rotor has stopped rotating, it signifies only that the oil flow to the rotor has ceased sufficient for the direction of rotation to be changed - therefore when stopping a rotor it must be noted that it will continue to freewheel for a considerable length of time after the stop button has been activated, in some case this can be up to 40 seconds.

HEAD ANGLE FLOAT

There are 2 methods available for selection and de-selection of this function; activation via the control unit - refer to #1 below, or activation via the joystick controls - refer to #2 below.

1. Pressing the Head Angle Float button – when activated the control unit will emit a single beep, the LED light will illuminate and the screen will momentarily display 'ANGLE FLOAT ✓' pressing the button again will deselect the function – the control unit will emit a single beep, the LED light will go out and the screen will momentarily display 'ANGLE FLOAT X'.

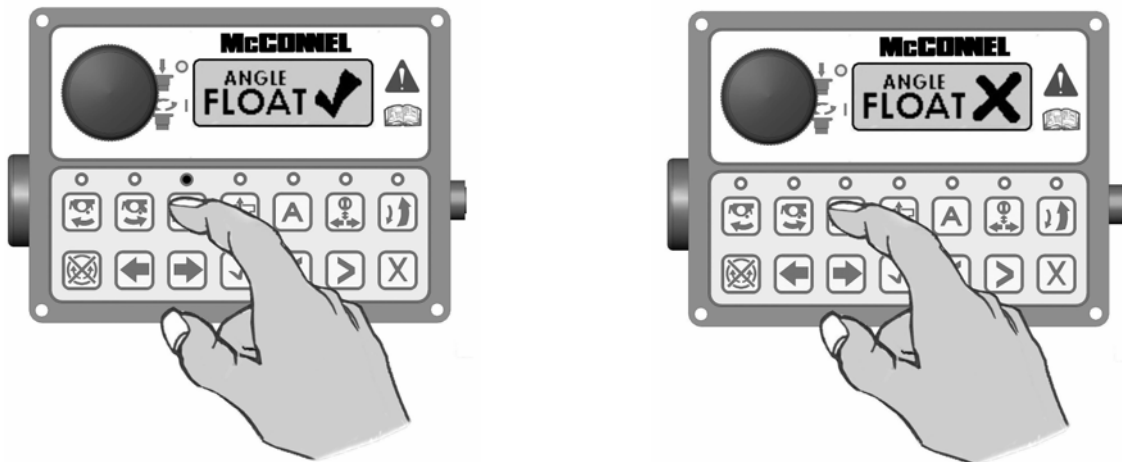

2. Press and hold in the lower frontal button (B1) on the joystick control and roll the left hand thumbwheel (T1) fully forwards – the control unit will emit a single beep, the LED light will illuminate and the screen will momentarily display 'ANGLE FLOAT ✓'.

To deselect press and hold in the lower frontal button (B1) on the joystick control and roll the left hand thumbwheel (T1) fully backwards – the control unit will emit a single beep, the LED light will go out and the screen will momentarily display 'ANGLE FLOAT X'.

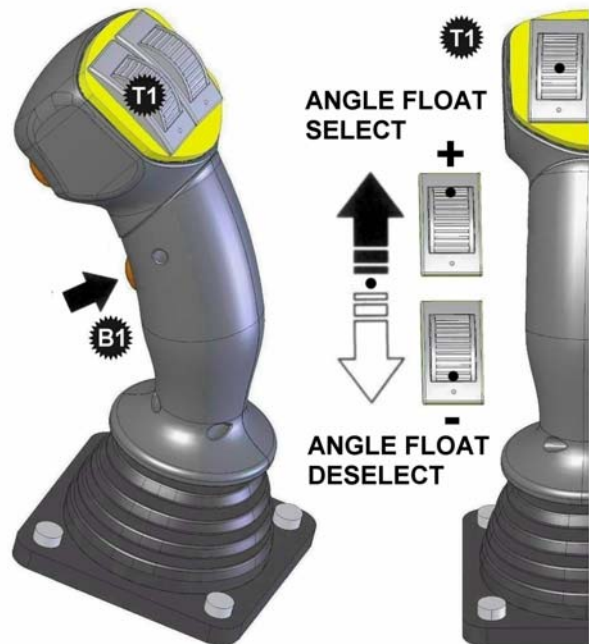

NOTE: When selecting or deselecting the function, the thumbwheel (T1) should be allowed to return to its centre position before releasing the lower frontal button (B1).

EDS FUNCTION (EDS Models) / LIFT FLOAT (Non EDS Models)

There are 2 methods available for selection and de-selection of this function; activation via the control unit - refer to #1 below, or activation via the joystick controls - refer to #2 below.

1. Pressing the EDS / Lift Float button will activate the relevant function – when activated the control unit will emit a single beep, the LED light will illuminate and the screen will momentarily display 'LIFT FLOAT ✓'. Pressing the button again will deselect the function – the control unit will emit a single beep, the LED light will go out and the screen will momentarily display 'LIFT FLOAT X'.

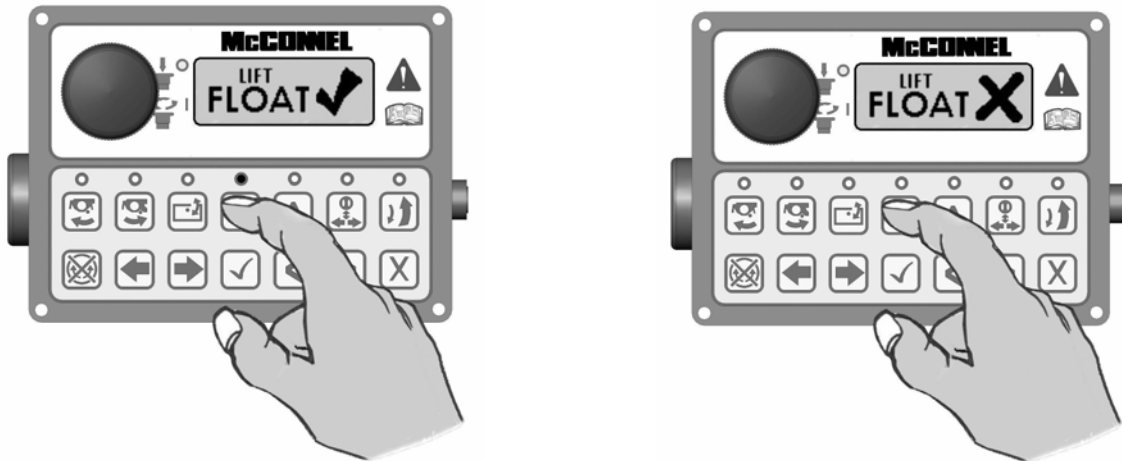

2. Press and hold in the lower frontal button (B1) on the joystick control and roll the right hand thumbwheel (T2) fully forwards – the control unit will emit a single beep, the LED light will illuminate and the screen will momentarily display 'LIFT FLOAT ✓'. To deselect press and hold in the lower frontal button (B1) on the joystick control and roll the right hand thumbwheel (T2) fully backwards – the control unit will emit a single beep, the LED light will go out and the screen will momentarily display 'LIFT FLOAT X'.

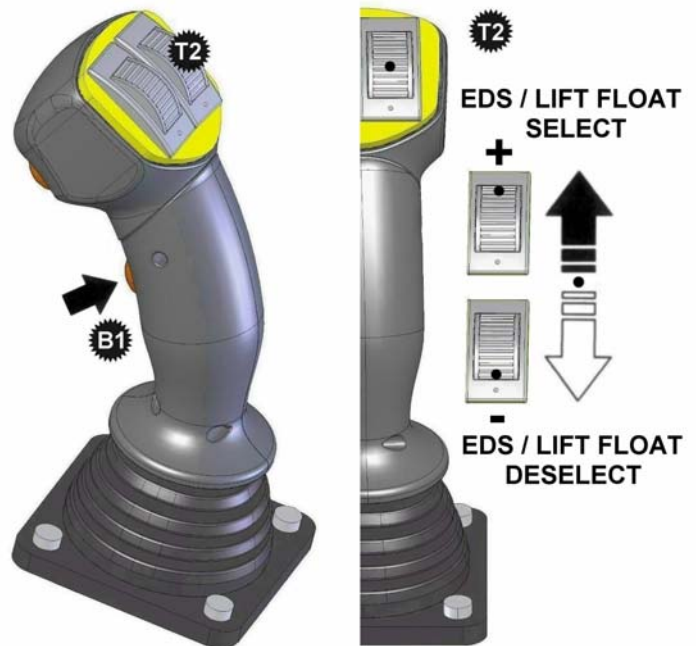

NOTE: When selecting or deselecting the function, the thumbwheel (T2) should be allowed to return to its centre position before releasing the lower frontal button (B1).

In the case of EDS models once this function is engaged and the rotor is running the EDS settings (SOFT – MED – HARD) will automatically be displayed on the control unit screen and can be scrolled through using button B1 on the joystick or the tick [✓] button on the control unit, if the rotor is not running the EDS settings can manually be viewed on the screen by pressing either [◀] [▶] buttons on the control unit and scrolling to the EDS work screen. When not in the EDS work settings screen, operation of button B1 activates the Slew/Tele swap function.

AUXILIARY FUNCTION CONTROL

This control selects either of the two diverter valves for the operation of additional equipment that may be fitted to the machine such as: Directional Ram, Orbiter Head Kit, Hydraulic Roller etc. There are 2 methods available for selection and de-selection of this function; activation via the control unit - refer to #1 below, or activation via the joystick controls - refer to #2 below.

1. Pressing the button momentarily will select Diverter Valve #1 – when activated the control unit will emit a single beep, the LED light will illuminate and the screen will momentarily display 'DIVERTER ON ✓'.
Holding the button in will select Diverter Valve 2.

NOTE: Diverter Valve #2 operates only whilst its selection button is held in – releasing the button will de-activate the valve.

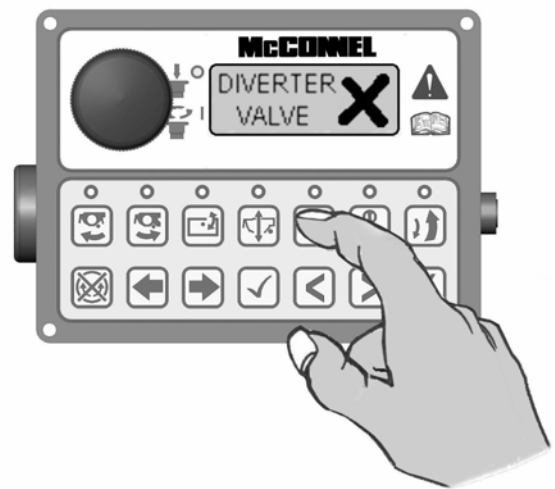
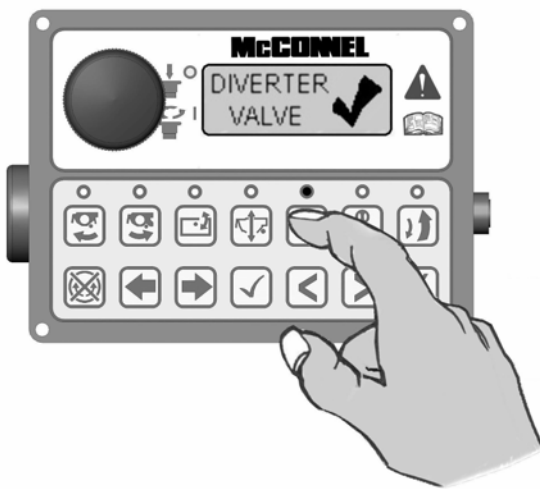

2. Pressing the upper frontal button (B2) on the joystick momentarily will select Diverter Valve #1 – when activated the control unit will emit a single beep, the LED light will illuminate and the screen will momentarily display 'DIVERTER ON ✓'.
Holding the button in will select Diverter Valve #2.

NOTE: Diverter Valve #2 only operates whilst its selection button is held in – releasing the button will de-activate the valve.



Button B2 not available on some models.

SLEW / TELE (MIDCUT) SWAP

IMPORTANT NOTE RELATING TO THE OPERATION OF PA180 MODELS ONLY:

Where these controls are fitted to PA180 models it must be noted that the default function of the right hand thumbwheel is Forward Extension operation and NOT Slew operation as stated below – therefore for PA180 Models only please read all text references to Slew operation on this page as Forward Extension operation.

This function swaps over the controls used to operate Slew/Tele (Midcut). By default, Slew operation is performed with the right hand thumbwheel (T2) and Tele or Midcut operation with the [◀] [▶] buttons on the control unit - in the swapped mode these will be the opposite way around and the LED on the control unit will be lit to indicate that the swapped mode is selected.

There are 2 methods available for swapping these controls; via the control unit - refer to #1 below, or via the joystick controls - refer to #2 below.

1. Press the swap button once to select swap mode – when activated the control unit will emit a single beep, the LED light will illuminate and the screen will momentarily display 'SLEW/TELE SWAP ✓'. Pressing the button again will deselect the function – the control unit will emit a single beep, the LED light will go out and the screen will momentarily display 'SLEW/TELE SWAP X'.

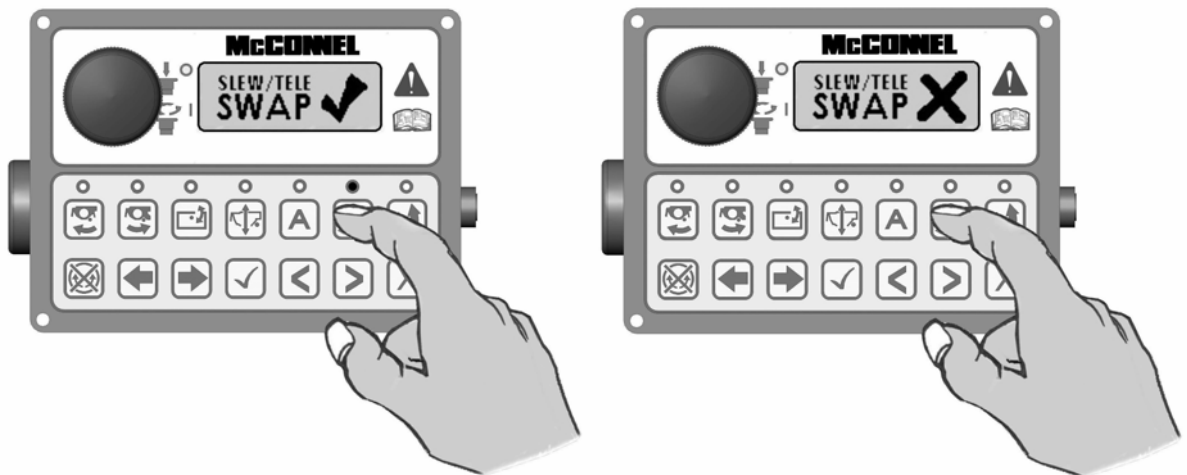

2. Press the joysticks lower frontal button (B1) once to select swap mode – when activated the control unit will emit a single beep, the LED light will illuminate and the screen will momentarily display 'SLEW/TELE SWAP ✓'. De-selection is with subsequent use of the same button - the control unit will emit a single beep, the LED light will go out and the screen will momentarily display 'SLEW/TELE SWAP X'.



AUTO RESET

This button is for the selection and de-selection of the Auto Reset function – pressing the button once will activate Auto Reset, the control unit will emit a single beep, the LED light will illuminate and the screen will momentarily display 'AUTO RESET ✓'. Pressing the button again will deselect the function – the control unit will emit a single beep, the LED light will go out and the screen will momentarily display 'AUTO RESET X'.

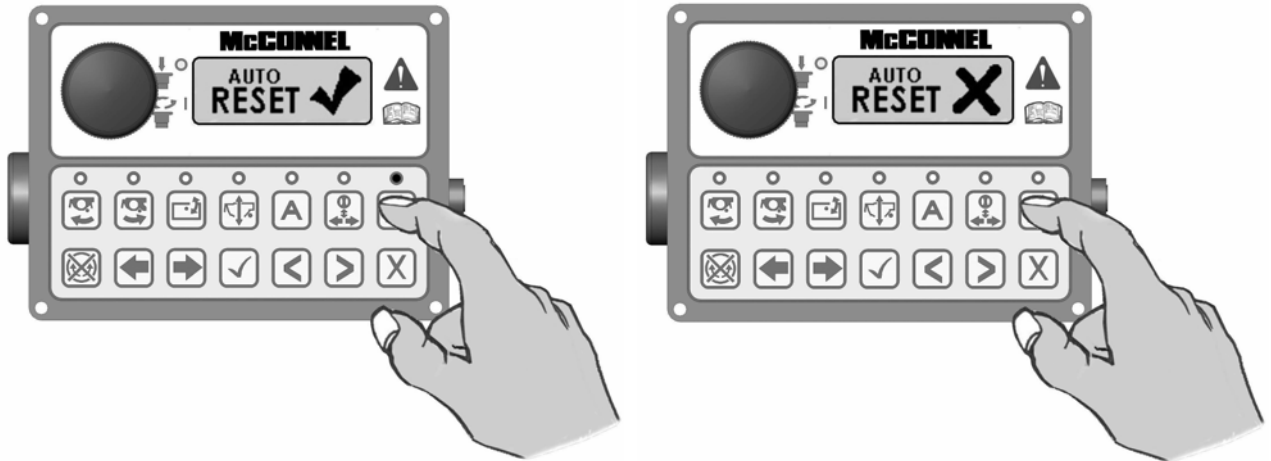

V4 CONTROL UNIT – Screen Access & Menu Buttons

Power on/off switch (E/Stop)



Speaker (audible confirmation)

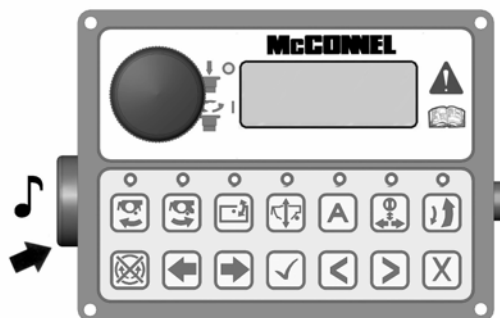

Command Button [✓]

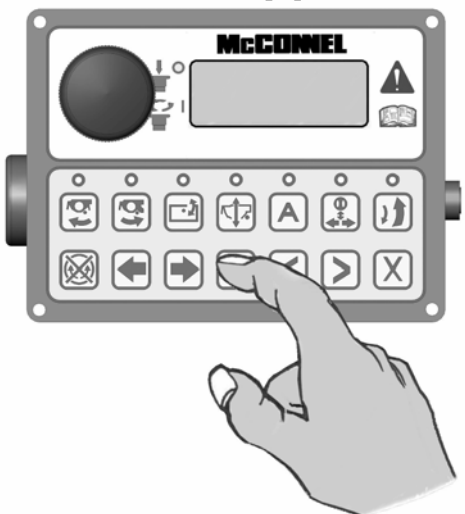

Command Button [X]

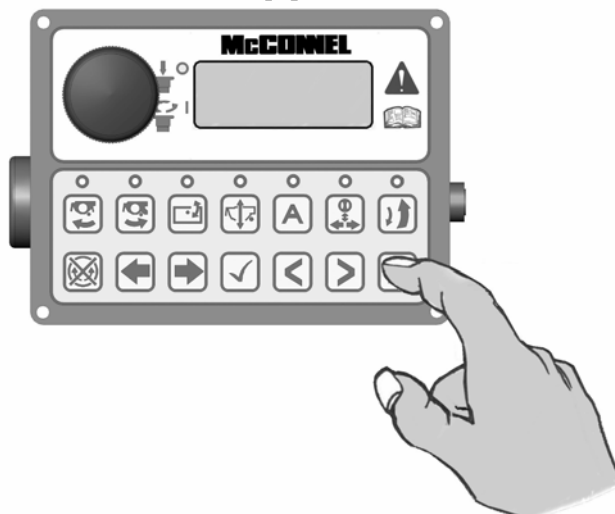

Navigate Forward Button [>]

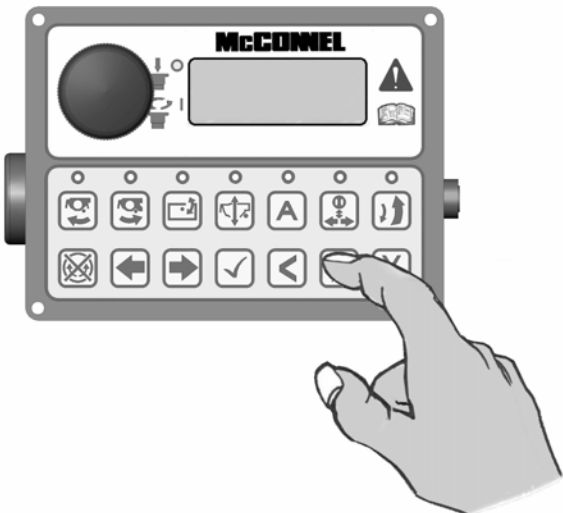

Navigate Back Button [<]



V4 CONTROL UNIT – LED Screen Display & Functions

IMPORTANT: Under no circumstances should a V4 Control Unit be connected to a V3 ACB (Auxiliary Control Box). Dedicated V3.5 & V4 Upgrade Kits are available from McConnel Limited – contact your local dealer or McConnel direct for available options and specific advice on this subject.

Rotate the ON/OFF switch on the control unit clockwise to power up controls - unit will emit a single beep and the LED screen will light up. *Note: 12 Volts at the battery are required for correct function.*

1. Screen will initially display the 'McConnel' name along with the selected PTO speed and the software versions installed on the Armrest and the Control Box respectively.

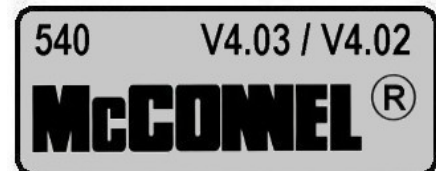

2. Pressing the scroll forward [▶] button once will display the rotor running times screen. 'TOT' displays the overall total running time of the rotor which is a cumulative total and cannot be reset. 'JOB' is a 'trip' total for the current rotor running time and can be reset to zero by pressing and holding the [X] button for 3 seconds.



3. Pressing either of the 'Rotor On' buttons will activate the 'egg timer' icon and display the rotor on image.



4. Pressing the EDS Lift float button will turn on the EDS (EDS Lift Float machines only). Then SOFT, MED or HARD will be added to the running screen.



5. Pressing the tick [✓] button when EDS is turned on will scroll through the EDS work settings of SOFT, MED or HARD. This may also be operated via button B1 on the joystick.



6. Pressing scroll forward [▶] button will now display the actual Tractor PTO running speed.



7. Scrolling forward [▶] again displays the Power Monitor screen.



Scrolling backwards [◀] will display the screens in the opposite order.

POWER MONITOR

When displayed the power screen will indicate to the operator the level of power being demanded by the cutting head – an ascending graphic indicates the power demand status from minimum on the left of the screen to maximum on the right.

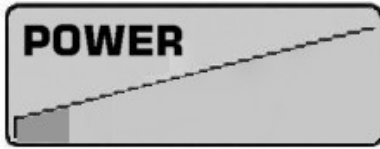

Power Status – Low Demand



Power Status – High Demand

When the power demand approaches the maximum limit an audible warning will alert the operator to indicate that the rotor is under excess load and at risk of 'stalling' – when this audible warning sounds the operator should reduce the forward tractor speed to protect the machine and regain efficient cutting power – the audible warning will cease when the power demand returns to an acceptable level.

In certain cases, cutting materials of extreme density may cause an increase in the power usage to the 'warning level' – in these types of conditions raising the cutting head into a less dense area of the material will regain an acceptable power demand. It is advisable that work in problematic high density materials be performed in several passes, lowering the cutting head slightly on each pass until the required cut height is achieved.

ADDITIONAL CONTROL & SCREEN SETTINGS

Additional settings available to the operator can be found within the settings menu of the control unit and accessible via the screen and menu buttons on the control panel.

Access is gained by simultaneously pressing the scroll [◀] [▶] buttons on the control panel until the unit emits a 'beep' and the setup screen appears on the LCD - the features can then be 'scrolled' to (forwards or backwards) by subsequent operation of either of the scroll [◀] [▶] buttons. When the required screen is reached the tick [✓] button should be pressed to enter the settings menu for that feature.

THUMB (Thumbwheel Switching) – this allows the operator to 'swap over' the left and right thumbwheel functions so that they control the opposing features. In most cases this setting will be dictated by the operators' personal preference and once chosen the operator will keep it in the selected mode.

Options are 'Normal' or 'Swap' – selection is by 'highlighting' the required option using either of the scroll [◀] [▶] buttons – the feature is then activated using the tick [✓] button. Pressing the [X] button exits the screen settings and returns to the normal work screen.

LED (Screen Contrast) - this setting allows the operator to adjust the contrast level of the LED display – the feature affords the option to increase or decrease the contrast level to suit differing lighting conditions; this is particularly useful on dull or sunny days where reduced or increased natural light can affect screen clarity.

Options are 'Increase Contrast' or 'Decrease Contrast' – selection is by 'highlighting' the required option using either of the scroll [◀] [▶] buttons – once selected that particular option can then be adjusted in incremental steps by pressing the tick [✓] button the required number of times to achieve the desired contrast. Pressing the [X] button exits the screen settings and returns to the normal work screen.

CAUTION: Avoid adjusting the contrast level to a state where the screen cannot be viewed as exiting the settings menu in this condition may render the LCD unusable as the 'on screen' prompts may no longer be visible to the user.

NOTE: Some screen menus are inaccessible to the operator – these are for factory or dealer use only and are password protected to avoid inadvertent changes to specific control settings.

TEST & FAULT FINDING SCREENS

The following screens are available for testing and fault finding purposes, these are:

JOYSTICK TEST SCREEN

This screen reports the status of the CAN (*Controller Area Network*) signal from the joystick during its various functions.

X : 0	B1: OFF
Y : 0	0
R1: 0	B2: OFF
R2: 0	0

X and Y Display

These report the joystick signal as it travels through its range of movements in its 2 axis – the 'X' axis being the 'Lift' up and down function and the 'Y' axis the 'Reach' in and out function.

With the joystick in the central (*neutral*) position both 'X' and 'Y' on the screen should read 0 (*zero*). When the joystick is moved through a specific axis the relevant readout will increase or decrease depending on the direction and distance of movement up to a maximum of +1000 in the fully forward or fully right position and -1000 in the fully back or fully left position. If the display reports a reading above the + or – 1000 figure at any point of full travel the joystick has developed a fault and should be repaired or replaced.

R1 and R2 Display

These report the signals from the 2 thumbwheels on the top of the joystick and are calibrated to read +1000 in the fully back position and -1000 in the fully forward position. If either of the 'R' readings are above the + or – 1000 figure at the point of full travel the thumbwheel has developed a fault and should be repaired or replaced.

B1 and B2 Display

These report the status of the 2 joystick buttons and will display 'ON' when the button is activated or 'OFF' when deactivated. The readings below B1 and B2 on the screen record usage of the buttons.

EDS STATUS SCREEN

Although this screen is present on all v4 controls, with the exception of the voltage reading, the information it reports is only actually relevant to machines fitted with EDS.

In addition to the aforementioned voltage reading the screen will report Lift Ram Pressure and Reach Position status – in each case these will display 'OK' when the system is working correctly. If 'FAULT' is displayed next to one or other feature it means a problem has been detected with that component and it should be investigated further to locate and correct the problem.

BATTERY	:12V
EDS PRESS:	OK
REACH POT:	OK

BATTERY	:12V
EDS PRESS:	FAULT
REACH POT:	FAULT

NOTE: As the pressure and position features are not present on Non EDS machines by default the screen will display 'FAULT' next to the features on these models – this is normal and should be ignored. The voltage reading will be relevant on all models.

REACH FUNCTION SCREEN

This screen displays the status of the joystick reach function and indicates to the operator if the controls are set for correct operation of the machine to the left hand side of the tractor or to the right hand side of the tractor. The hand symbol with a ✓ displayed on it indicates the operating side that is currently active.



L/H Machine Operation



R/H Machine Operation

OPERATING WITH 'SLEW' SELECTED

When the slew relief valve setting is exceeded oil is displaced from the slew ram allowing the arm to pivot backwards horizontally and the obstacle to be cleared.

Re-setting the head into the work position is carried out manually by selecting 'SLEW OUT' on the control assembly.

OPERATING WITH 'HEAD ANGLE FLOAT' SELECTED

The selection of the angle float on the controls simultaneously connects both gland and base side of the angling ram to the tank. The ram rod then can extend and retract freely allowing the flail head to automatically follow the contours of the ground.

Angle float is an 'operator friendly' mowing feature and can be used singly or in conjunction with lift float.

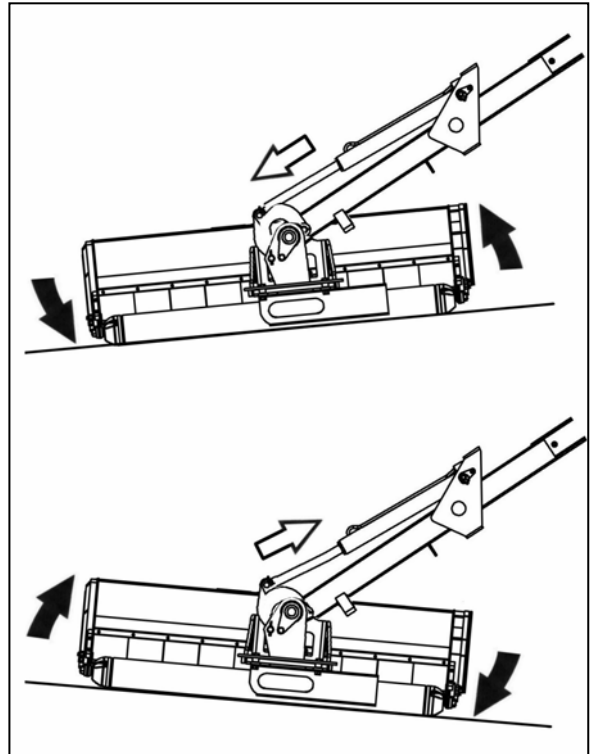

GRASS MOWING

It is recommended that both lift float and angle float are used when grass mowing.

To ensure maximum visibility of the head during work it is suggested that the 1st and 3rd rams are used to control the flailhead reach – the 2nd ram should be fully or nearly closed. The 2nd and 3rd rams can be used for the same operation but the operator's visibility of the front of the head and its immediate cutting area may be impaired.

EASY DRIVE SYSTEM (EDS)

The EDS system automatically controls and adjusts the height of the flailhead during work – once selected on the controls it enables the flailhead to accurately follow the contours of the ground without the need for additional adjustment of the lift service by the operator, thus allowing increased working speed.

The proportion of the flailhead weight taken by the lift ram is factory preset to provide optimum ground following characteristics - therefore if the flailhead is replaced with one that is of considerable weight difference you will need to contact the McConnel Service Department to have the float response re-calibrated to suit the new head.

POWERED SLEW

The machine features a powered arm slewing capability of 138° - from 30° rearwards of the right angle position or forwards of it by up to 108° - the latter, with use of the turnaround kit, makes it possible to work with the flailhead positioned directly in front of the tractor - *caution should be adopted when operating the machine in this position as the flailhead and its immediate cutting area will not be visible from the operator position.*

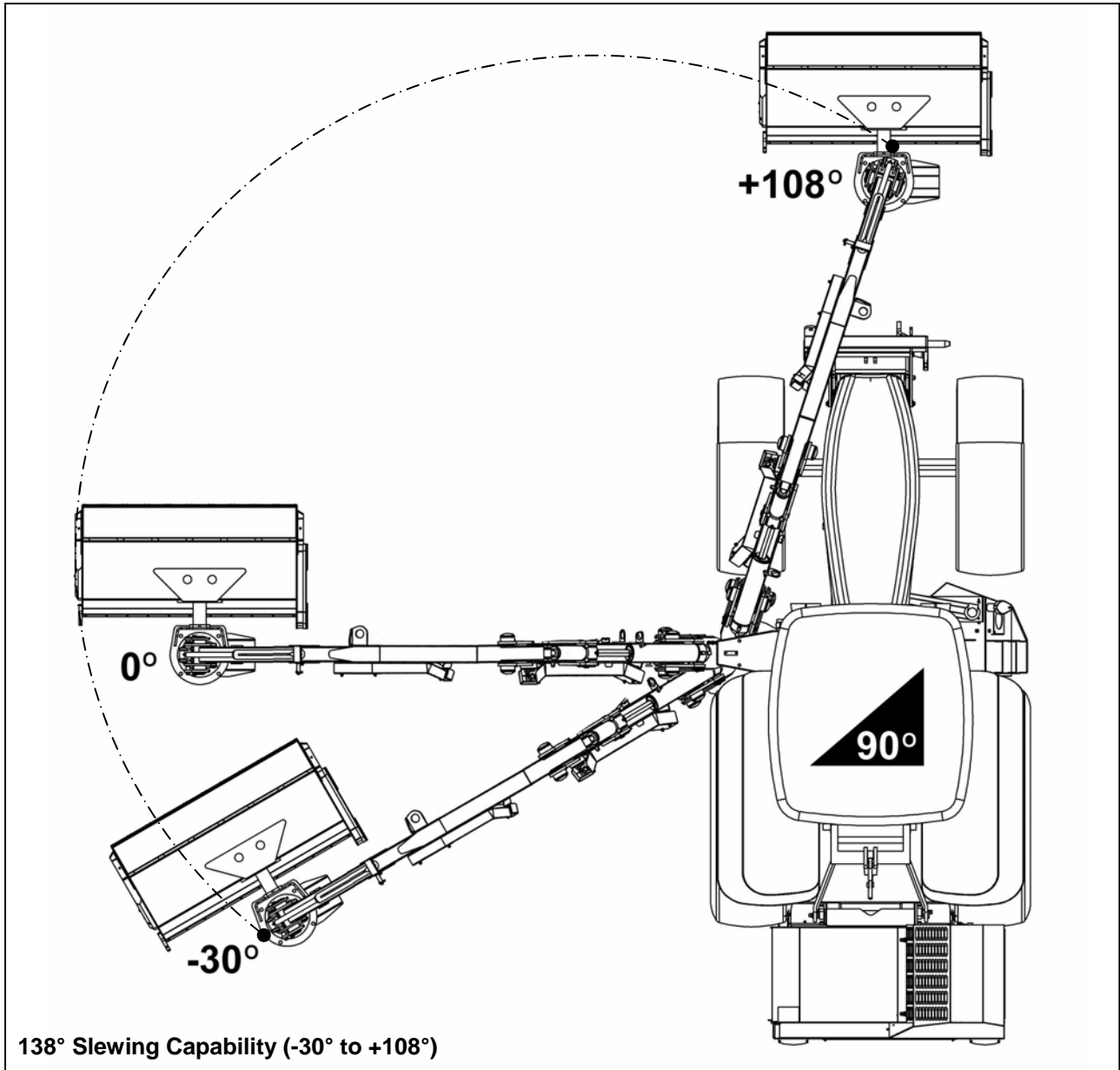

POWERED HEAD ROTATION

The flailhead can be rotated in both the horizontal and vertical planes by activation of the controls that operate the head rotation ram and angle ram respectively. Both functions share the same button on the control panel and an LED light next to the button indicates to the operator which particular function is selected.

- LED light OFF indicates that the ANGLE function is active.
- LED light ON indicates that the HEAD ROTATION function is active.

Adjustment to the position of the head, in whichever function is selected, is made by rotating the knob of the joystick in the desired direction – refer to diagram below.

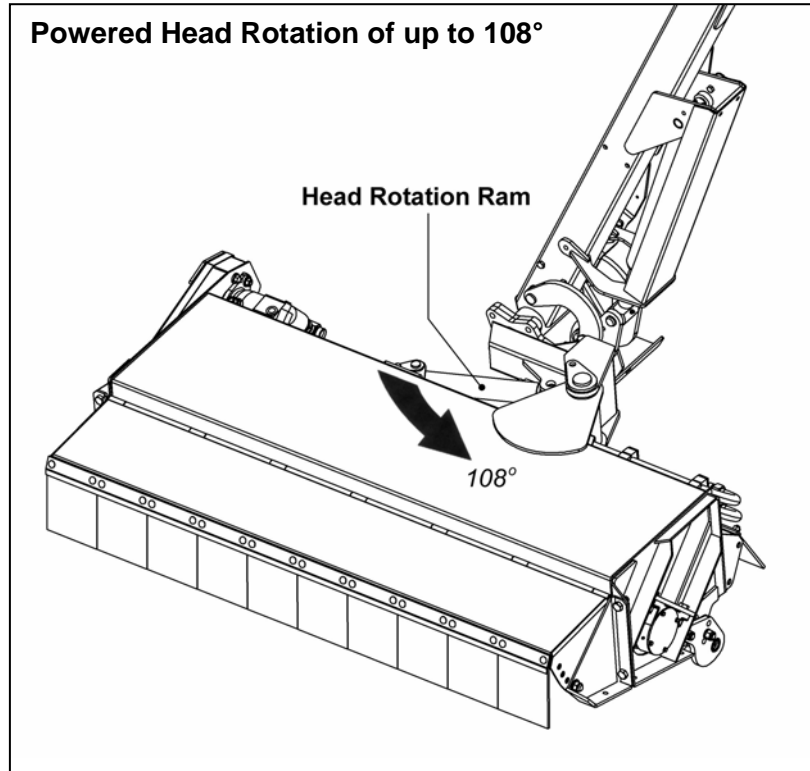
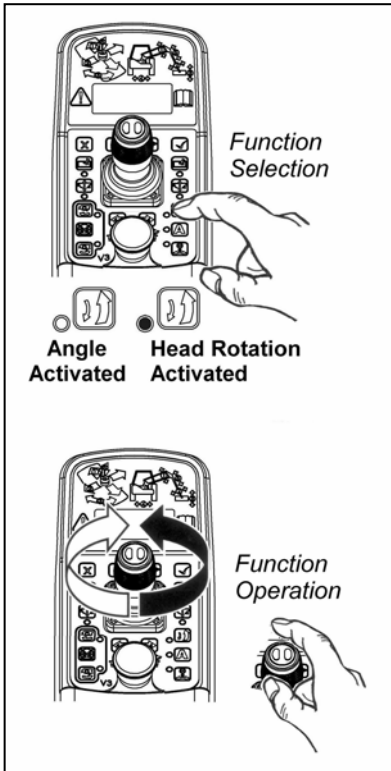

The powered head rotation in the horizontal plane permits the head to be rotated by any angle up to 108° anti-clockwise from the normal work position at right angles to the arm. This function allows the flailhead to be positioned in front of the tractor for both forward travel cutting and for stowage of the head on the transport cradle during transportation.

DANGER

Never attempt to perform adjustments or maintenance to the flailhead with the machine or tractor running.

FLAILHEAD

WIRE TRAP

The flailhead is equipped with a 'wire cutting' edge welded into the underside. This is to ensure that the ends of any wire that may be entwined in the rotor are cut and fall within the confines of the flailhead.

IMPORTANT: This plate should not be interfered with in any way.

Any wire caught in the rotor must be immediately removed (*see below*).

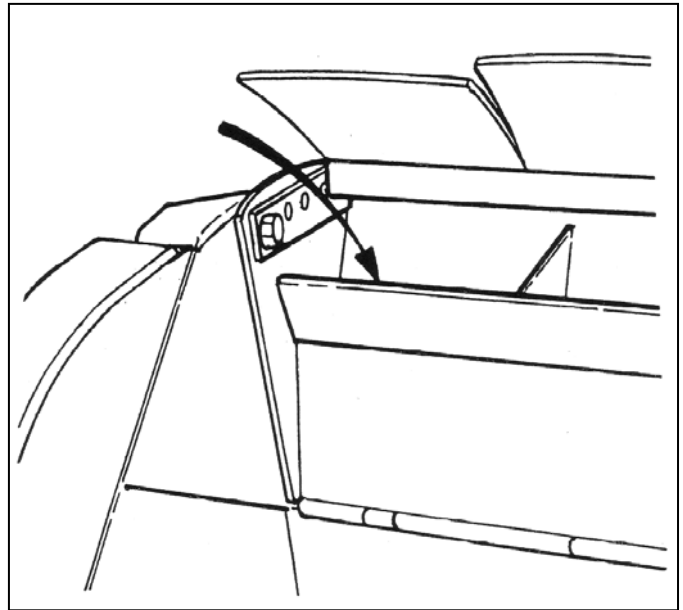

REMOVING WIRE

- Select rotor '**OFF**' and wait until it has **stopped rotating**.
- **STOP** the tractor and **only then** remove wire.

NEVER reverse the rotor in an attempt to unwind any wire.

Engaging Drive - Piston Hydraulic Machines

- Ensure Rotor is in 'Stop' position.
- Switch main power 'On'.
- Prime pump and switch pump power 'On'
- Allow the oil to circulate for a few minutes.
- Place the flail head in a safe position.
- Increase engine speed to a 'high idle' and switch to 'On' selecting the rotation required - *after initial surging the rotor will run at an even speed.*

Rotor Operating Speed

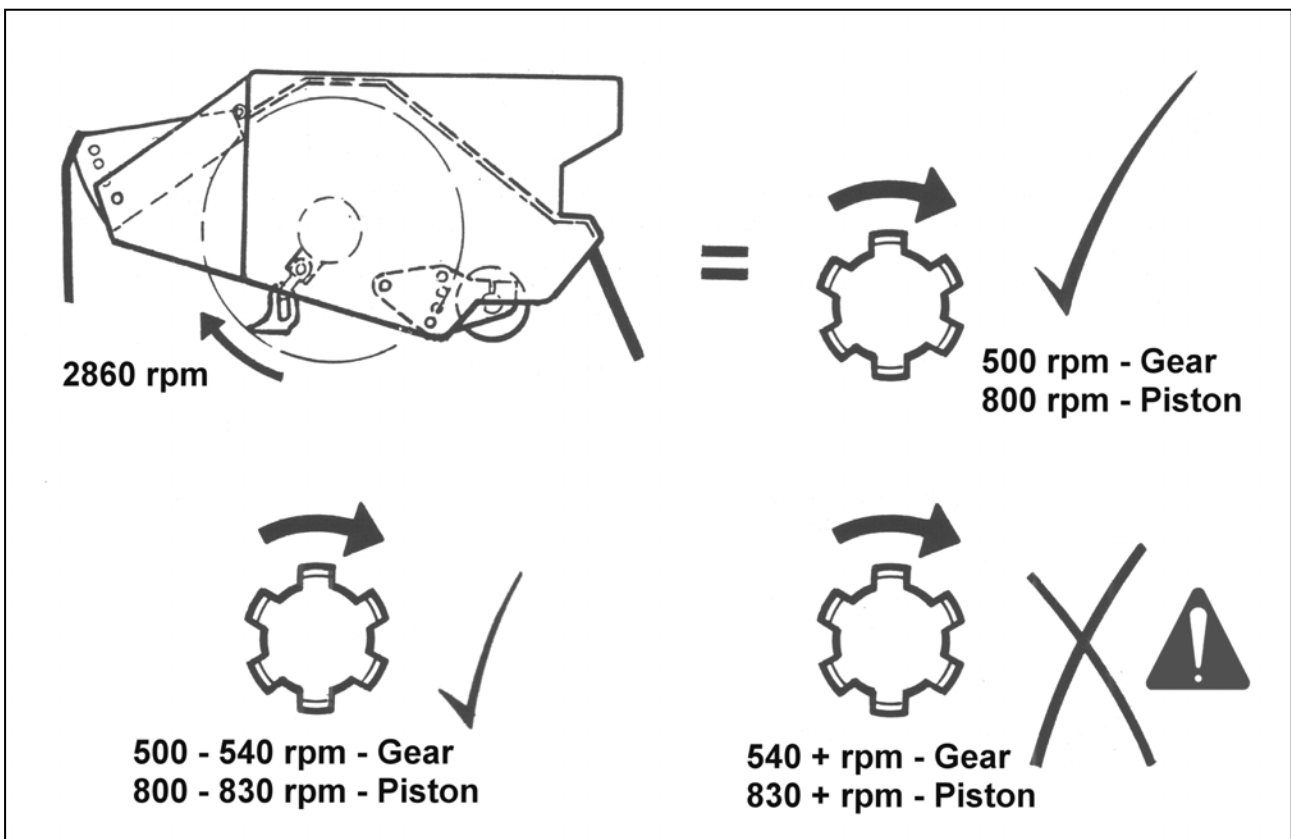

Tractor Forward Speed

The material being cut determines tractor forward speed. Forward speed can be as fast as that which allows the flail head sufficient time to cut the vegetation properly.

Too fast a speed will be indicated by over frequent operation of the breakaway system, a fall off in tractor engine revs and a poor finish to the work leaving ragged uncut tufts and poorly mulched cuttings.

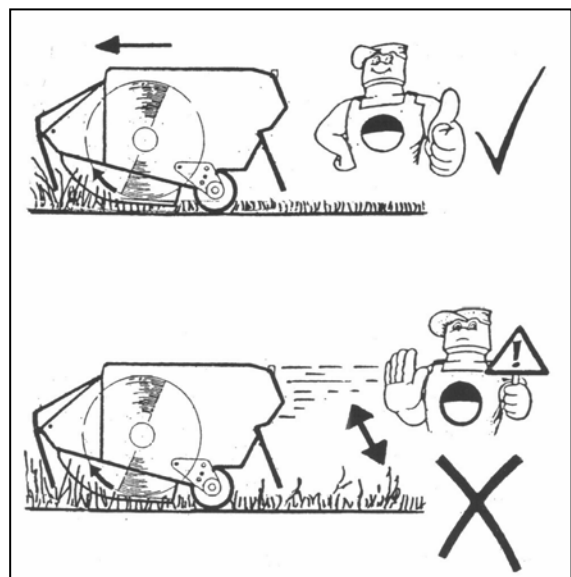

FLAIL SELECTION

Four types of flail are available in order to provide the optimum cutting characteristics required for the various types of work being carried out, these are as follows:

1. Designed specifically for **general mowing** activities.

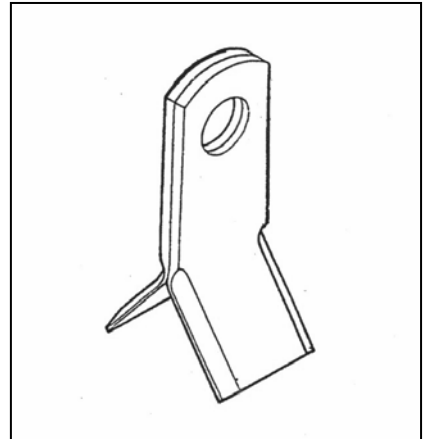

2. Designed specifically for **heavy-duty hedge cutting**; this flail is capable of dealing with materials up to 75/80mm diameter. - *These flails will also provide a good mowing finish but will require considerably more power when used for this purpose.*

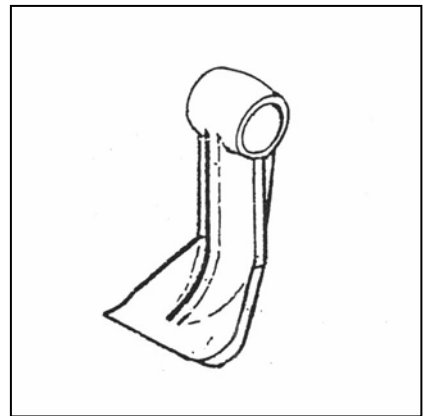

3. Designed for **general-purpose work**, this flail is suitable for both mowing and the cutting of hedges up to two years growth.

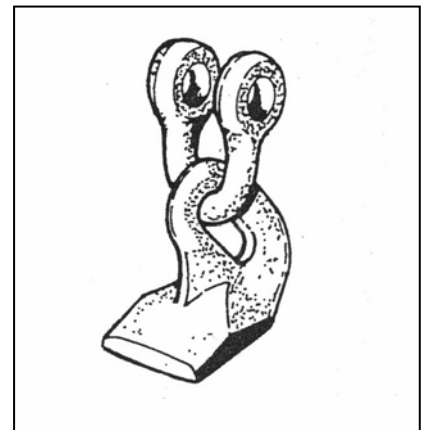

4. Designed specifically for **heavy-duty hedge cutting**; this flail is capable of dealing with materials up to 75/80mm diameter. - *These flails will also provide a good mowing finish but will require considerably more power when used for this purpose.*

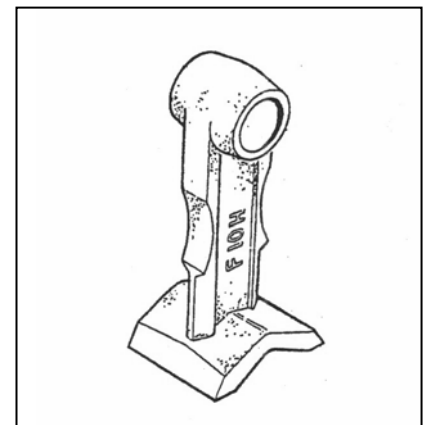

TRANSPORTATION CRADLE

A transportation cradle mounted onto the front end of the tractor provides a safe compact storage location for the flailhead during transportation of the machine as well as offering additional support for the arms. The cradle has 2 available positions – transportation position and work position.

For transportation of the machine the cradle should be placed in the down position which allows the flailhead to be positioned onto it with its roller located and supported in the trough of the cradle. The work position is with the cradle raised upwards to the front of the tractor.

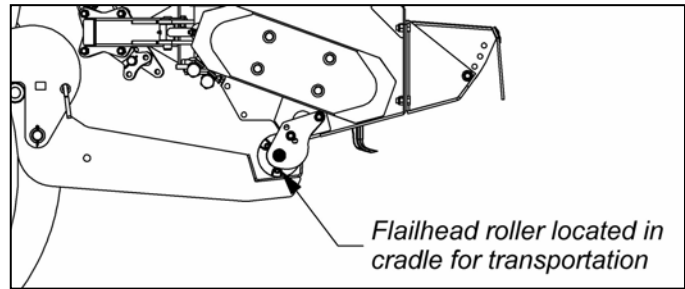

In both positions the cradle must be locked into position using pins and lynch pins in the appropriate locating holes on each side of the cradle. Refer to diagrams below.

Cradle must be locked into whichever position on both sides using pins & lynch pins as indicated below

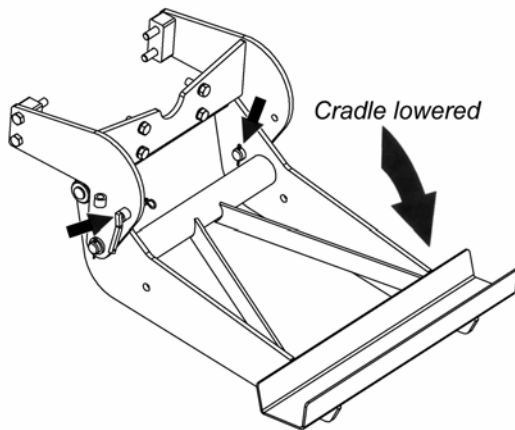

TRANSPORT POSITION

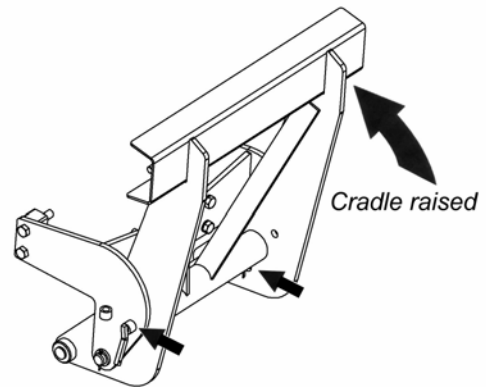

WORK POSITION

Transport Position

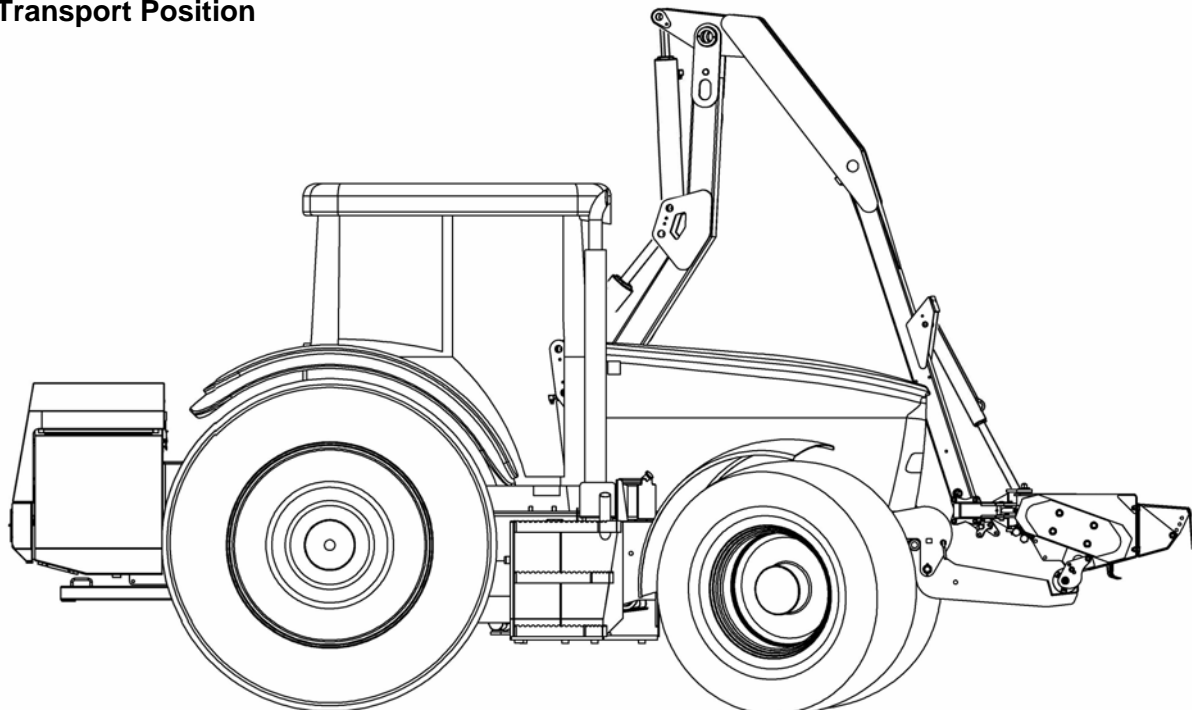

TRANSPORTING THE MACHINE

When in transport the PTO must be disengaged and the power to the control box switched off.

Transport Speed

The acceptable speed whilst in transport will vary greatly depending upon ground conditions; the maximum recommended speed is < 20mph. In any conditions avoid driving at speeds that will cause exaggerated 'bouncing' - this may create undue strain on the machine and tractor mounting points.

Transport Height

The approximate height of the machine in the transport position is 3.9m but this will vary depending on the ride height of the driving unit to which the machine is attached. It is the responsibility of the operator to be fully aware of the height of the machine they are operating at all times and must exercise care when working or manoeuvring under low obstacles such as bridges, building etc. and with extreme caution near power lines.

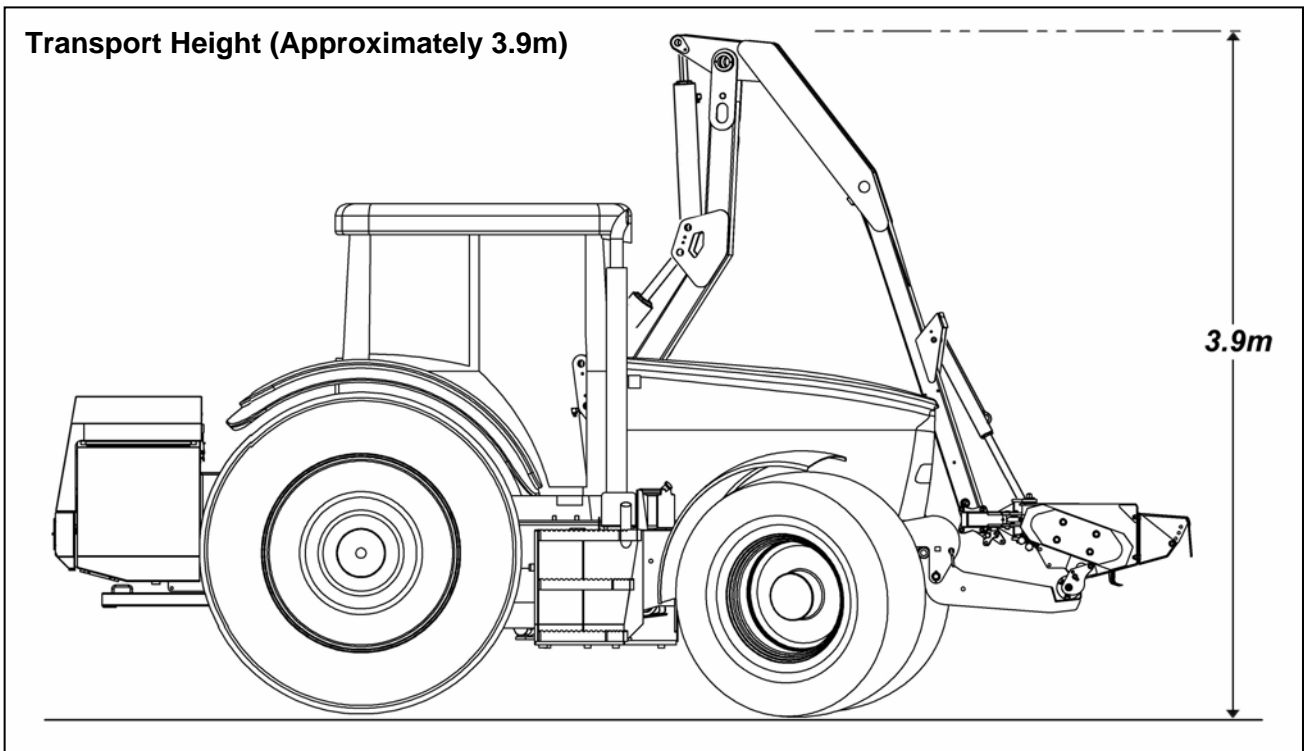

OVERHEAD POWER LINES (OHPLs)

It cannot be stressed enough the dangers involved when working in the vicinity of Overhead Power Lines (OHPLs). Some of our machines are capable of reach in excess of 8 metres (26'); they have the potential to well exceed, by possibly 3 metres (9' 9"), the lowest legal minimum height of 5.2 metres from the ground for 11,000 and 33,000 volt power lines.

Remember electrocution can occur without actually coming into contact with a power line as electricity can 'flashover' when machinery gets close to it.



WARNING: All operators must read the following information and be aware of the risks and dangers involved when working in the vicinity of Overhead Power Lines (OHPLs).

Wherever possible the safest option is always to avoid working in areas close to OHPLs. Where unavoidable, all operators must perform a risk assessment and implement a safe procedure and system of work – see *following page for details*. All operators should perform a risk assessment before operating the machine within 10m horizontal distance of any OHPLs.

Minimum Heights for Overhead Power Lines

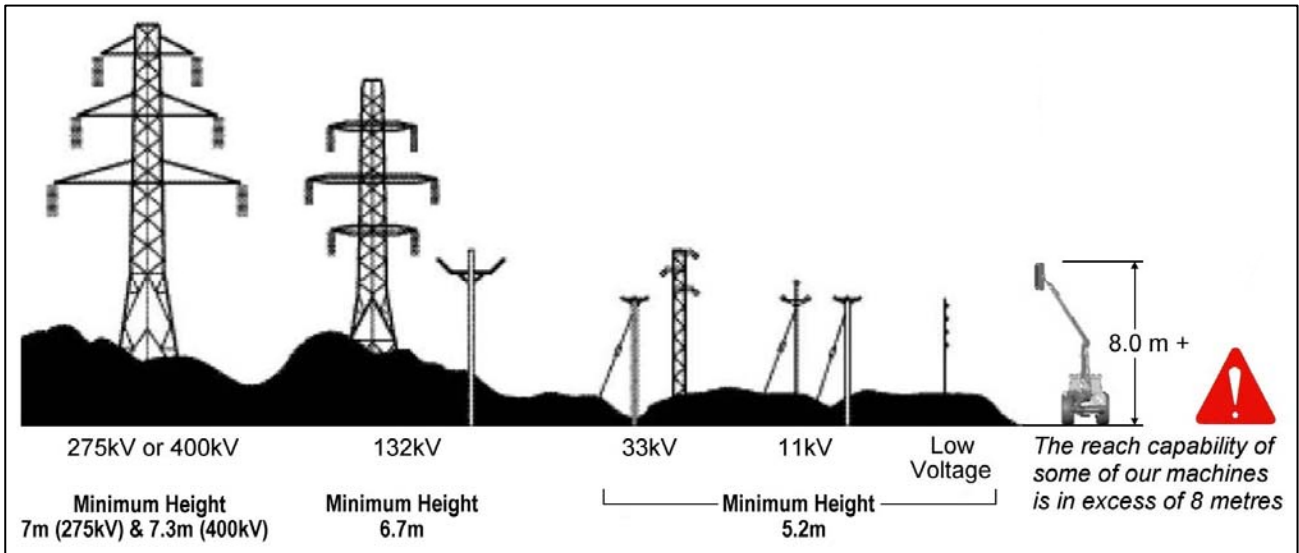

Absolute Minimum Exclusion Zones for Specific Overhead Power Lines

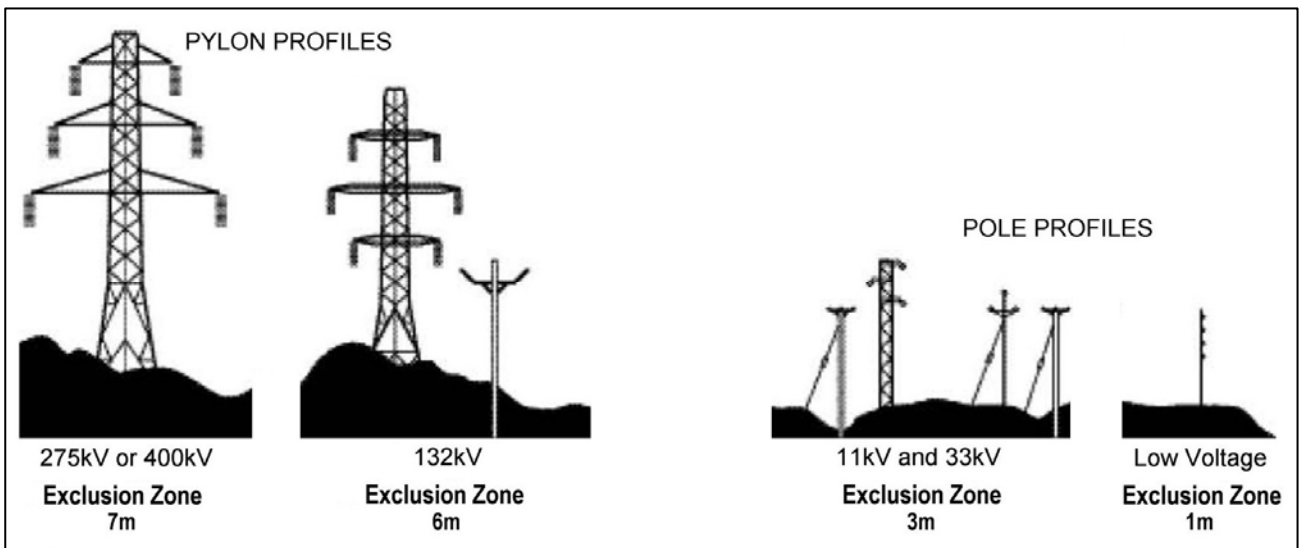

Definitions of Exclusion Zones

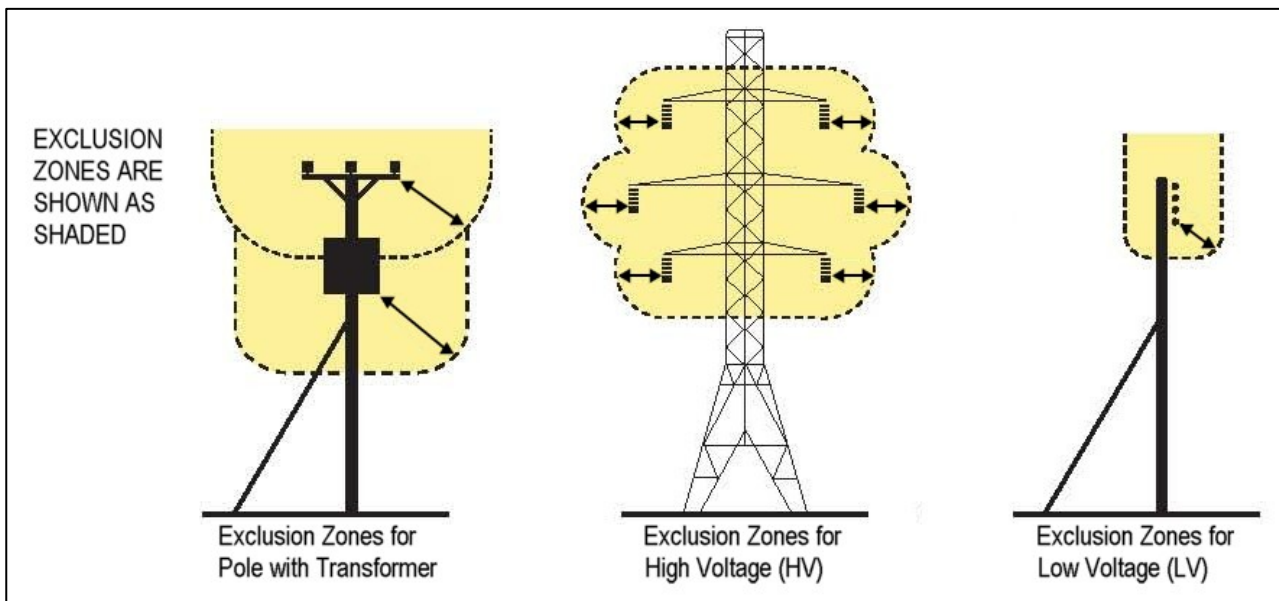

Risk Assessment

Before starting to work near OHPLs you should always assess the risks. The following points should be observed;

- **Know** the risks of contacting OHPLs and the risk of flashover.
- **Find out** the maximum height and maximum vertical reach of your machine.
- **Find out** the location and route of all Power Lines within the work area.
- **Find out** the operating voltage of all Power Lines within the work area.
- **Contact** the local Distribution Network Operator (DNO) who will be able to advise you on the operating voltage, safe minimum clearance distance for working, and additional precautions required.
- **Never** attempt to operate the machine in exclusion zones.
- **Always** work with extreme caution and plan your work ahead to avoid high risk areas.
- **If doubt exists** do not work in the area – never risk the safety of yourself or others.

Emergency Action for Accidents Involving Electricity

- Never touch an overhead line - even if it has been brought down by machinery, or has fallen. Never assume lines are dead.
- When a machine is in contact with an overhead line, electrocution is possible if anyone touches both the machine and the ground. Stay in the machine and lower any raised parts in contact or drive the machine out of the lines if you can.
- If you need to get out to summon help or because of fire, jump out as far as you can without touching any wires or the machine - keep upright and away.
- Get the electricity company to disconnect the supply. Even if the line appears dead, do not touch it - automatic switching may reconnect the power.

Further information and leaflets on this and other agricultural safety subjects are available on the 'Health & Safety Executive' website at the following address: www.hse.gov.uk/pubns/agindex.htm

HYDRAULIC HOSE CONNECTION POINTS – Bulkhead Plate

The diagram below shows the hydraulic hose connection points on the bulkhead plate of the rear tank frame assembly – the positions of the hoses are indicated on the plate to assist the operator or fitter in identifying the correct connection point.

On hydraulic ram connections G = Gland Port and B = Base Port.

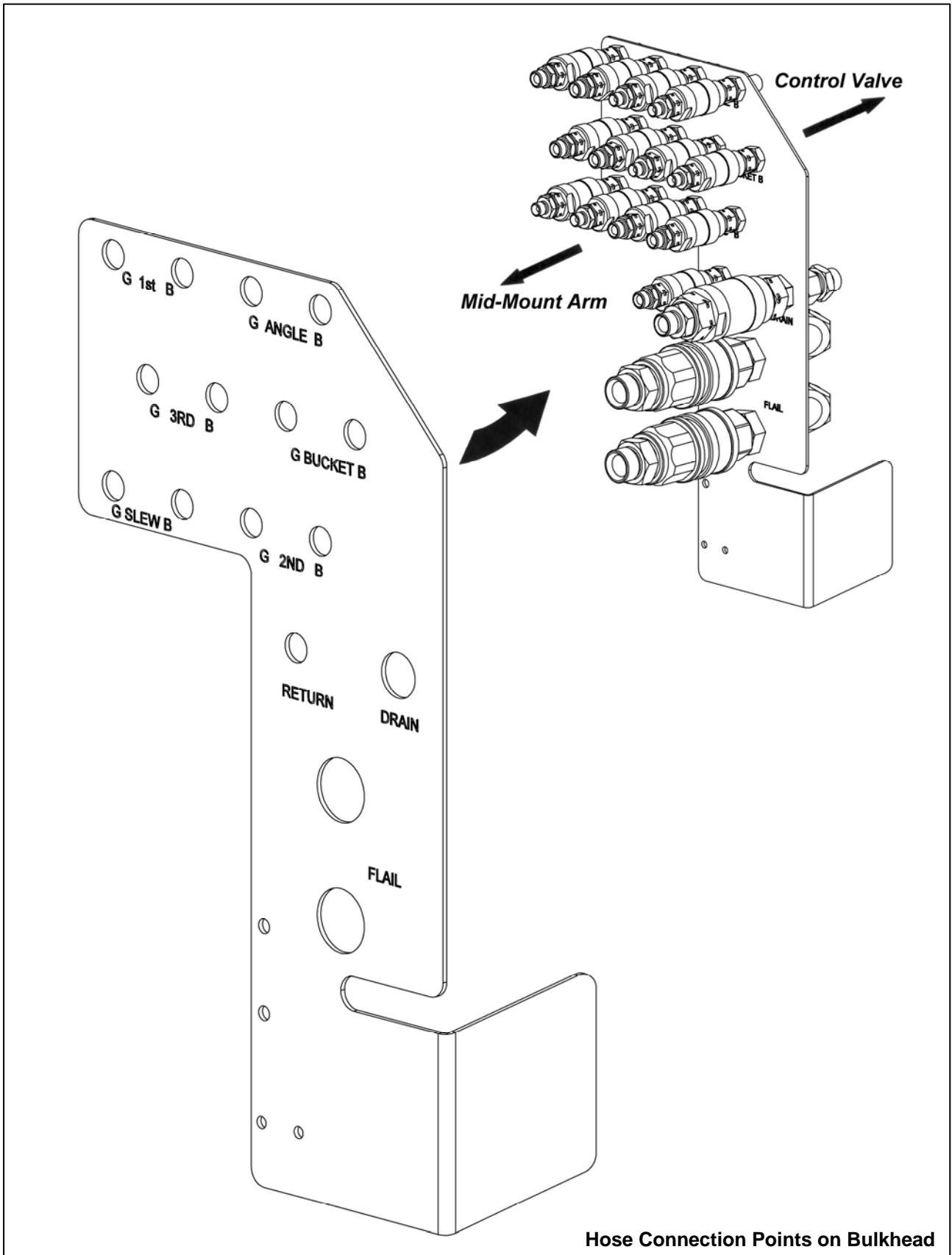

MAINTENANCE - Lubrication

Arm Unit Lubrication

Lubricate all greasing points at regular intervals using general-purpose lithium based grease. The diagram below shows the locations of the arms greasing points.

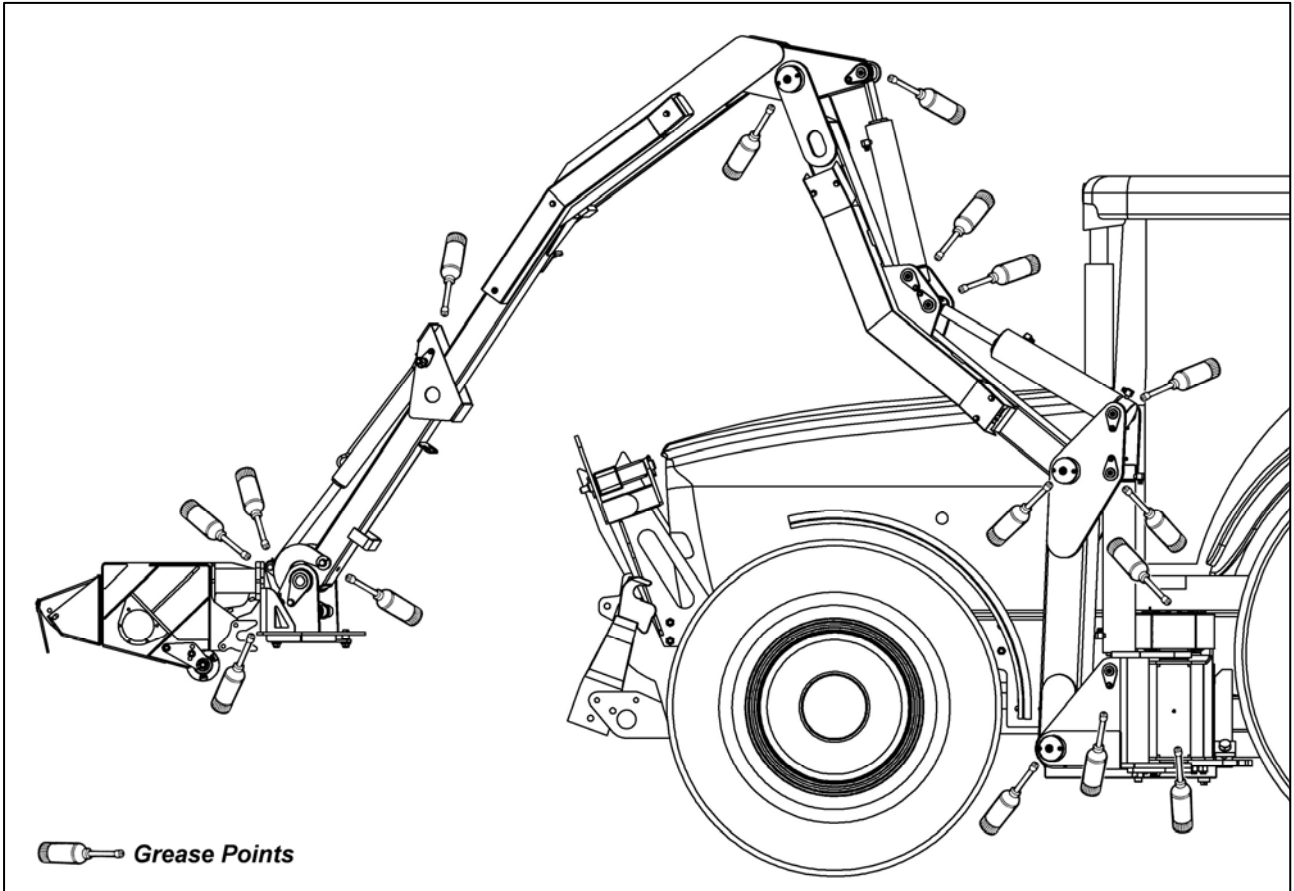

PTO Shaft Lubrication

Lubricate all points indicated in the diagram below at the intervals stated using general-purpose lithium based grease.

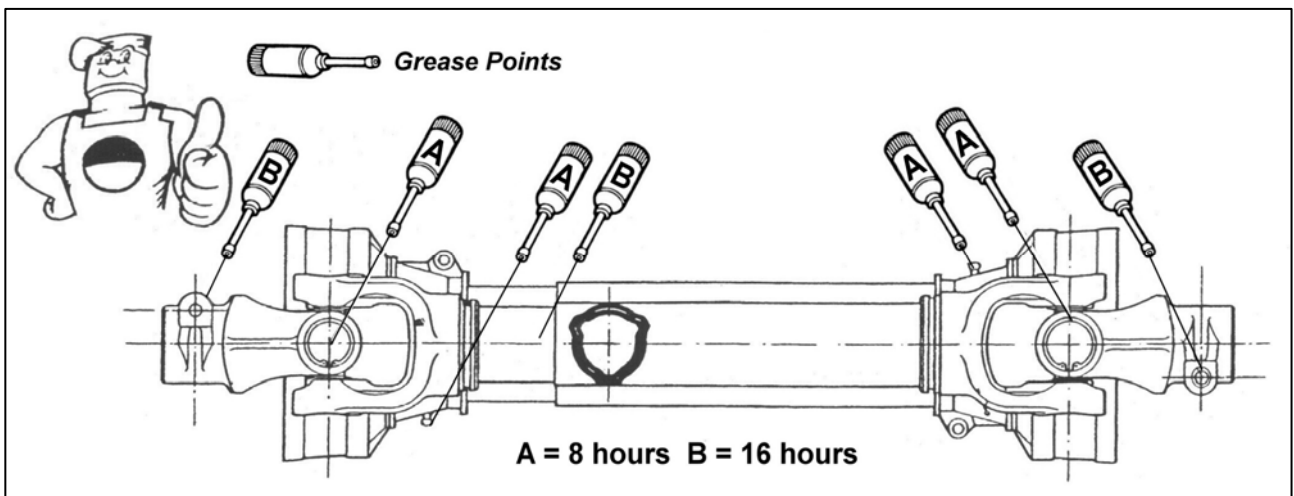

Gearbox Lubrication

Refill the gearbox with 0.5 Litres of either SAE80 or ISO100 lubricant after an initial 50 hours of use and thereafter at annual or 500-hour intervals - whichever occurs earliest.

MAINTENANCE – Hydraulic System

Hydraulic Oil Supply

Check the oil level in the reservoir on a daily basis. No fixed time periods can be quoted in regard to replacement of the oil in the hydraulic system as operating conditions and maintenance standards may vary widely. Whatever, the oil should always be changed at the first signs of oxidation; this may be noticeable by burnt or scorched oil odours and the darkening or thickening of the oil.

Contamination

The hydraulic system can sometimes become contaminated by moisture resulting from condensation entrapped in the oil – this cannot be removed by filtration, therefore water contamination is progressive.

General contamination can be reduced by:

- Ensuring that the reservoir cap and surrounding area is cleaned prior to removal.
- Keeping the reservoir cap and surrounding area clean.
- Using clean containers when replenishing the system.
- Working in a clean dry dust free environment when replacing or replenishing the oil.
- Regular servicing of the filtration system.

Filtration

A 125-micron suction strainer and a low-pressure 10-micron full flow return filter protect the machine.

Suction Strainer - the suction strainer is permanently fixed within the reservoir. Should symptoms of pump cavitation or spongy intermittent operation occur the reservoir should be drained and flushed out with a suitable cleaning agent such as clean diesel oil.

Return Line Filter - filter elements should be changed after the first 50 hours of work and thereafter at 500-hour intervals. It is important to note the hours worked as should the filter become blocked an internal by-pass within the canister will operate and no symptoms of filter malfunction will be occur to jog your memory or indicate that the oil is no longer being filtered.

Hydraulic Hoses

The condition of all hydraulic hoses should be carefully checked on a regular basis – any hoses that have become chaffed or damaged on their outer casing should be securely wrapped with waterproof adhesive tape to stop the metal braid from rusting. Hoses that have suffered damage to the metal braid should be replaced at the earliest possible opportunity.

Hydraulic Hose Replacement

- Replace hoses one at a time to avoid the risk of wrong connections.
- Run the replacement hose alongside the damaged hose before removing it to ensure it is correctly routed.
- When a hose is attached to an additional fitting or union, use a second spanner on the union to avoid breaking both seals.
- Do not use jointing compound on the threads.
- Avoid twisting the hose. Adjust the hose line to ensure freedom from rubbing or trapping before tightening the hose end connections.

Before changing hoses study the installation as they are carefully calculated to prevent hose damage during use. Always replace hoses in exactly the same manner and location, this is especially important for flail hoses where they must be crossed 'upper to lower' at the dipper and head pivots.



McConnel Limited, Temeside Works, Ludlow, Shropshire SY8 1JL. England.
Telephone: 01584 873131. Facsimile: 01584 876463. www.mcconnel.com