

Publication 903
April 2018
Part No. 24214.03
Revision: 13.02.19

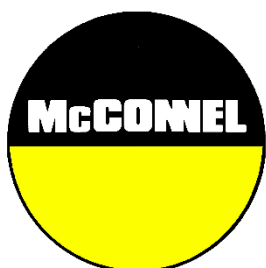

MAGNUM

MEDIUM DUTY FLAIL MOWERS

Models: 190 / 225 / 245 / 270
Front / Rear Mounted Shredder Mowers

Operator Manual



IMPORTANT

VERIFICATION OF WARRANTY REGISTRATION

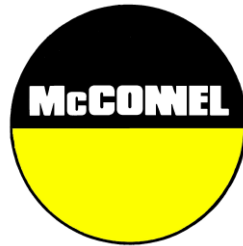

DEALER WARRANTY INFORMATION & REGISTRATION VERIFICATION

It is imperative that the selling dealer registers this machine with McConnel Limited before delivery to the end user – failure to do so may affect the validity of the machine warranty.

To register machines go to the McConnel Limited web site at www.mcconnel.com, log onto 'Dealer Inside' and select the 'Machine Registration button' which can be found in the Service Section of the site. Confirm to the customer that the machine has been registered in the section below.

Should you experience any problems registering a machine in this manner please contact the McConnel Service Department on 01584 875848.

Registration Verification

Dealer Name:
Dealer Address:
Customer Name:
Date of Warranty Registration:/...../..... Dealer Signature:

NOTE TO CUSTOMER / OWNER

Please ensure that the above section above has been completed and signed by the selling dealer to verify that your machine has been registered with McConnel Limited.

IMPORTANT: During the initial 'bedding in' period of a new machine it is the customer's responsibility to regularly inspect all nuts, bolts and hose connections for tightness and re-tighten if required. New hydraulic connections occasionally weep small amounts of oil as the seals and joints settle in – where this occurs it can be cured by re-tightening the connection – refer to torque settings chart below. The tasks stated above should be performed on an hourly basis during the first day of work and at least daily thereafter as part of the machines general maintenance procedure.

CAUTION: DO NOT OVER TORQUE HYDRAULIC FITTINGS AND HOSES

TORQUE SETTINGS FOR HYDRAULIC FITTINGS

HYDRAULIC HOSE ENDS		
BSP	Setting	Metric
1/4"	18 Nm	19 mm
3/8"	31 Nm	22 mm
1/2"	49 Nm	27 mm
5/8"	60 Nm	30 mm
3/4"	80 Nm	32 mm
1"	125 Nm	41 mm
1.1/4"	190 Nm	50 mm
1.1/2"	250 Nm	55 mm
2"	420 Nm	70 mm

PORT ADAPTORS WITH BONDED SEALS		
BSP	Setting	Metric
1/4"	34 Nm	19 mm
3/8"	47 Nm	22 mm
1/2"	102 Nm	27 mm
5/8"	122 Nm	30 mm
3/4"	149 Nm	32 mm
1"	203 Nm	41 mm
1.1/4"	305 Nm	50 mm
1.1/2"	305 Nm	55 mm
2"	400 Nm	70 mm

WARRANTY POLICY

WARRANTY REGISTRATION

All machines must be registered, by the selling dealer with McConnel Ltd, before delivery to the end user. On receipt of the goods it is the buyer's responsibility to check that the Verification of Warranty Registration in the Operator's Manual has been completed by the selling dealer.

1. LIMITED WARRANTIES

1.01. *All mounted machines supplied by McConnel Ltd are warranted to be free from defects in material and workmanship from the date of sale to the original purchaser for a period of 12 months, unless a different period is specified.*

All Self Propelled Machines supplied by McConnel Ltd are warranted to be free from defects in material and workmanship from the date of sale to the original purchaser for a period of 12 months or 1500 hours. Engine warranty will be specific to the Manufacturer of that unit.

1.02. *All spare parts supplied by McConnel Ltd and purchased by the end user are warranted to be free from defects in material and workmanship from the date of sale to the original purchaser for a period of 6 months. All parts warranty claims must be supported by a copy of the failed part invoice to the end user. We cannot consider claims for which sales invoices are not available.*

1.03. *The warranty offered by McConnel Ltd is limited to the making good by repair or replacement for the purchaser any part or parts found, upon examination at its factory, to be defective under normal use and service due to defects in material or workmanship. Returned parts must be complete and unexamined. Pack the component(s) carefully so that any transit damage is avoided. All ports on hydraulic items should be drained of oil and securely plugged to prevent seepage and foreign body ingress. Certain other components, electrical items for example, may require particular care when packing to avoid damage in transit.*

1.04. *This warranty does not extend to any product from which McConnel Ltd's serial number plate has been removed or altered.*

1.05. *The warranty policy is valid for machines registered in line with the terms and conditions detailed and on the basis that the machines do not extend a period of 24 months or greater since their original purchase date, that is the original invoice date from McConnel Limited.*

Machines that are held in stock for more than 24 months cannot be registered for warranty.

1.06. *This warranty does not apply to any part of the goods, which has been subjected to improper or abnormal use, negligence, alteration, modification, fitment of non-genuine parts, accident damage, or damage resulting from contact with overhead power lines, damage caused by foreign objects (e.g. stones, iron, material other than vegetation), failure due to lack of maintenance, use of incorrect oil or lubricants, contamination of the oil, or which has served its normal life. This warranty does not apply to any expendable items such as blades, belts, clutch linings, filter elements, flails, flap kits, skids, soil engaging parts, shields, guards, wear pads, pneumatic tyres or tracks.*

1.07. *Temporary repairs and consequential loss - i.e. oil, downtime and associated parts are specifically excluded from the warranty.*

1.08. *Warranty on hoses is limited to 12 months and does not include hoses which have suffered external damage. Only complete hoses may be returned under warranty, any which have been cut or repaired will be rejected.*

1.09. *Machines must be repaired immediately a problem arises. Continued use of the machine after a problem has occurred can result in further component failures, for which McConnel Ltd cannot be held liable, and may have safety implications.*

1.10. *If in exceptional circumstances a non McConnel Ltd part is used to effect a repair, warranty reimbursement will be at no more than McConnel Ltd's standard dealer cost for the genuine part.*

- 1.11. *Except as provided herein, no employee, agent, dealer or other person is authorised to give any warranties of any nature on behalf of McConnell Ltd.*
- 1.12. *For machine warranty periods in excess of 12 months the following additional exclusions shall apply:*
 - 1.12.1. *Hoses, exposed pipes and hydraulic tank breathers.*
 - 1.12.2. *Filters.*
 - 1.12.3. *Rubber mountings.*
 - 1.12.4. *External electric wiring.*
 - 1.12.5. *Bearings and seals*
 - 1.12.6. *External Cables, Linkages*
 - 1.12.7. *Loose/Corroded Connections, Light Units, LED's*
 - 1.12.8. *Comfort items such as Operator Seat, Ventilation, Audio Equipment*
- 1.13. *All service work, particularly filter changes, must be carried out in accordance with the manufacturer's service schedule. Failure to comply will invalidate the warranty. In the event of a claim, proof of the service work being carried out may be required.*
- 1.14. *Repeat or additional repairs resulting from incorrect diagnosis or poor quality previous repair work are excluded from warranty.*

NB Warranty cover will be invalid if any non-genuine parts have been fitted or used. Use of non-genuine parts may seriously affect the machine's performance and safety. McConnell Ltd cannot be held responsible for any failures or safety implications that arise due to the use of non-genuine parts.

2. REMEDIES AND PROCEDURES

- 2.01. *The warranty is not effective unless the Selling Dealer registers the machine, via the McConnell web site and confirms the registration to the purchaser by completing the confirmation form in the operator's manual.*
- 2.02. *Any fault must be reported to an authorised McConnell Ltd dealer as soon as it occurs. Continued use of a machine, after a fault has occurred, can result in further component failure for which McConnell Ltd cannot be held liable.*
- 2.03. *Repairs should be undertaken within two days of the failure. Claims submitted for repairs undertaken more than 2 weeks after a failure has occurred, or 2 days after the parts were supplied will be rejected, unless the delay has been authorised by McConnell Ltd. Please note that failure by the customer to release the machine for repair will not be accepted as a reason for delay in repair or submitting warranty claims.*
- 2.04. *All claims must be submitted, by an authorised McConnell Ltd Service Dealer, within 30 days of the date of repair.*
- 2.05. *Following examination of the claim and parts, McConnell Ltd will pay, at their discretion, for any valid claim the invoiced cost of any parts supplied by McConnell Ltd and appropriate labour and mileage allowances if applicable.*
- 2.06. *The submission of a claim is not a guarantee of payment.*
- 2.07. *Any decision reached by McConnell Ltd. is final.*

3. LIMITATION OF LIABILITY

- 3.01. *McConnell Ltd disclaims any express (except as set forth herein) and implied warranties with respect to the goods including, but not limited to, merchantability and fitness for a particular purpose.*
- 3.02. *McConnell Ltd makes no warranty as to the design, capability, capacity or suitability for use of the goods.*
- 3.03. *Except as provided herein, McConnell Ltd shall have no liability or responsibility to the purchaser or any other person or entity with respect to any liability, loss, or damage caused or alleged to be caused directly or indirectly by the goods including, but not limited to, any indirect, special, consequential, or incidental damages resulting from the use or operation of the goods or any breach of this warranty. Notwithstanding the above limitations and warranties, the manufacturer's liability hereunder for damages incurred by the purchaser or others shall not exceed the price of the goods.*
- 3.04. *No action arising out of any claimed breach of this warranty or transactions under this warranty may be brought more than one (1) year after the cause of the action has occurred.*

4. MISCELLANEOUS

- 4.01. McConnel Ltd may waive compliance with any of the terms of this limited warranty, but no waiver of any terms shall be deemed to be a waiver of any other term.*
- 4.02. If any provision of this limited warranty shall violate any applicable law and is held to be unenforceable, then the invalidity of such provision shall not invalidate any other provisions herein.*
- 4.03. Applicable law may provide rights and benefits to the purchaser in addition to those provided herein.*

McConnel Limited



DECLARATION OF CONFORMITY

Conforming to EU Machinery Directive 2006/42/EC

We,

McCONNEL LIMITED, Temeside Works, Ludlow, Shropshire SY8 1JL, UK

Hereby declare that:

The Product; *Tractor Mounted Flail Mower*

Product Code; *MA19, MA22, MA24, MA27*

Serial No. & Date Type

Manufactured in; *United Kingdom*

Complies with the required provisions of the Machinery Directive 2006/42/EC
The machinery directive is supported by the following harmonized standards;

- BS EN ISO 12100 (2010) Safety of machinery – General principles for design – Risk assessment and risk reduction.
- BS EN 349 (1993) + A1 (2008) Safety of machinery - Minimum distances to avoid the entrapment with human body parts.
- BS EN ISO 14120 (2015) Safety of machinery - Guards general requirements for the design and construction of fixed and movable guards.
- BS EN 4413 (2010) Hydraulic fluid power. Safety requirements for systems and their components.

McCONNEL LIMITED operates an ISO 9001:2008 quality management system, certificate number: FM25970.

This system is continually assessed by the;

British Standards Institution (BSI), Beech House, Milton Keynes, MK14 6ES, UK
BSI is accredited by UK Accreditation Service, accreditation number: UKAS 003.
The EC declaration only applies if the machine stated above is used in accordance with the operating instructions.

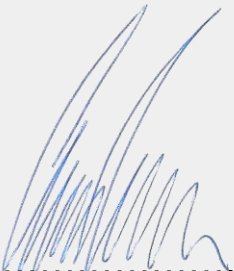
Signed  *Responsible Person*
CHRISTIAN DAVIES on behalf of McCONNEL LIMITED

Status: *General Manager*

Date: *January 2018*

FLAIL MOWER INSPECTION AND MAINTENANCE

A daily equipment inspection of the tractor and mower should be conducted before the equipment is used. You may use the inspection sheets to assist with these daily inspections. Any damaged or missing guards should be repaired or replaced before operating the mower. Failure to repair the damaged shield can result in objects being thrown from the mower and possibly hitting the operator or bystander.

Inspect the Mower for Safe Operating Condition

- Make sure the driveline guards and shielding are in place and in good repair.
- Inspect the chain guards, flexible and/or solid deflector thrown object shielding to assure that they are in place on the front and rear of the mower deck and in good repair. Repair or replace any damaged or missing thrown object shields.
- Ensure the mower cutting height is set high enough to reduce the possibility of the mower blades contacting the ground. Actual height will be dependent on the ground conditions. Increase the height when working in rough or undulating conditions.
- Inspect for broken, chipped, bent, missing, or severely worn blades. Replace damaged blades before operating the mower. Ensure the blade retaining bolts and fasteners are secure and tight.
- Lubricate the driveline universal joints and telescoping members daily.
- Inspect the wheel lug bolt/nuts to assure that they are tight.
- If mower is equipped with pneumatic tires, make sure they have the required air pressure.
- Inspect for worn or damaged decals and safety instructions. Replace unreadable, damaged or missing safety decals.
- Follow the operator's manual(s) inspection and maintenance instructions for lubricating parts, and keeping thrown object shielding, driveline guards, rotating parts shields, mower blades and decals in good repair.

Inspect the Tractor for Safe Operating Condition:

- Inspect the controls, lights, SMVs (Slow Moving Vehicle sign), seat belts, and ROPS to assure that they are in place and in good working order.
- Be sure the tires, wheels, lug bolts/nuts are in good condition.
- Make sure the tractor brakes and steering are in proper operating condition.
- Follow the operator's manual(s) inspection and maintenance procedures for keeping the tractor in good and safe condition before operating.

The inspection sheet on the following page should be kept in this book as a record. A second sheet is included for you to cut out and photocopy.



FLAIL MOWERS PRE-OPERATION Inspection

Mower ID _____ Date: _____ Shift: _____

WARNING



Before conducting the inspection, make sure the tractor engine is off, with the key removed, all rotation has stopped and the tractor is in park with the parking brake engaged. Make sure the mower is resting on the ground or is securely blocked up and supported and all hydraulic pressure has been relieved.

Item	Condition at start of shift	Specific Comments if not O.K.
The Operator's Manual is in the Canister on the mower		
All Warning Decals are in place, clean and legible		
The Hyd. Cylinder pins are tight and correctly secured		
The Hyd Cylinder hose connections are tight		
There are no oil leaks		
There are no damaged hoses		
Flails are not missing chipped, broken or excessively worn		
The Flail bolts are tight		
The Front & Rear Flaps are fitted and in good condition		
The Skid shoes are in good condition & tight		
The Rotor Bearings are in good condition and greased		
The Roller bearings are in good condition and greased		
There are no cracks or holes in flail casing		
The drive line/gearbox shaft guard is in good condition		
The drive line/gearbox shaft guard is correctly secured		
Driveline telescoping members & u-joints are lubricated		
Driveline yokes are securely attached to tractor & mower		
All linkage mounting pins are securely fastened		

Operators Signature: _____

DO NOT OPERATE an UNSAFE TRACTOR or MOWER



TRACTOR PRE-OPERATION Inspection

Power Arm ID _____ Date: _____ Shift: _____

WARNING



Before conducting the inspection, make sure the tractor engine is off, the key is removed all rotation has stopped and the tractor is in park with the parking brake engaged. Any implement attached to the tractor is firmly on the ground.

Item	Condition at start of shift	Specific Comments if not O.K.
The flashing lights function properly.		
All lights are clean and working correctly		
All cab windows are clean and wipers working correctly		
The SMV sign, where required, is clean and visible.		
The tyres are in good condition with correct pressure.		
The wheel nuts are tight.		
The tractor brakes are in good condition.		
The steering linkage is in good condition.		
There are no visible oil leaks.		
The hydraulic controls function properly.		
The ROPS or ROPS cab is in good condition.		
The seatbelt is in place and in good condition.		
The 3-point hitch is in good condition.		
The drawbar/pick up hook is secure & in good condition		
The PTO master shield is in place.		
The engine oil level is full.		
The brake fluid level is full.		
The power steering fluid level is full.		
The fuel level is adequate.		
The engine coolant fluid level is full.		
The radiator & oil cooler are free of debris.		
The air filter is in good condition		

Operators Signature: _____

DO NOT OPERATE an UNSAFE TRACTOR or MOWER



FLAIL MOWERS PRE-OPERATION Inspection

Mower ID _____ Date: _____ Shift: _____

WARNING



Before conducting the inspection, make sure the tractor engine is off, with the key removed, all rotation has stopped and the tractor is in park with the parking brake engaged. Make sure the mower is resting on the ground or is securely blocked up and supported and all hydraulic pressure has been relieved.

Item	Condition at start of shift	Specific Comments if not O.K.
The Operator's Manual is in the Canister on the mower		
All Warning Decals are in place, clean and legible		
The Hyd. Cylinder pins are tight and correctly secured		
The Hyd Cylinder hose connections are tight		
There are no oil leaks		
There are no damaged hoses		
Flails are not missing chipped, broken or excessively worn		
The Flail bolts are tight		
The Front & Rear Flaps are fitted and in good condition		
The Skid shoes are in good condition & tight		
The Rotor Bearings are in good condition and greased		
The Roller bearings are in good condition and greased		
There are no cracks or holes in flail casing		
The drive line/gearbox shaft guard is in good condition		
The drive line/gearbox shaft guard is correctly secured		
Driveline telescoping members & u-joints are lubricated		
Driveline yokes are securely attached to tractor & mower		
All linkage mounting pins are securely fastened		

Operators Signature: _____

DO NOT OPERATE an UNSAFE TRACTOR or MOWER



TRACTOR PRE-OPERATION Inspection

Power Arm ID _____ Date: _____ Shift: _____

WARNING



Before conducting the inspection, make sure the tractor engine is off, the key is removed all rotation has stopped and the tractor is in park with the parking brake engaged. Any implement attached to the tractor is firmly on the ground.

Item	Condition at start of shift	Specific Comments if not O.K.
The flashing lights function properly.		
All lights are clean and working correctly		
All cab windows are clean and wipers working correctly		
The SMV sign, where required, is clean and visible.		
The tyres are in good condition with correct pressure.		
The wheel nuts are tight.		
The tractor brakes are in good condition.		
The steering linkage is in good condition.		
There are no visible oil leaks.		
The hydraulic controls function properly.		
The ROPS or ROPS cab is in good condition.		
The seatbelt is in place and in good condition.		
The 3-point hitch is in good condition.		
The drawbar/pick up hook is secure & in good condition		
The PTO master shield is in place.		
The engine oil level is full.		
The brake fluid level is full.		
The power steering fluid level is full.		
The fuel level is adequate.		
The engine coolant fluid level is full.		
The radiator & oil cooler are free of debris.		
The air filter is in good condition		

Operators Signature: _____

DO NOT OPERATE an UNSAFE TRACTOR or MOWER

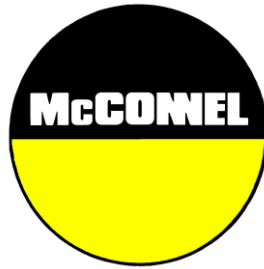

For Safety and Performance...

ALWAYS READ THE BOOK FIRST

McCONEL LIMITED

**Temeside Works
Ludlow
Shropshire
England**

**Telephone: +44 (0)1584 873131
www.mcconel.com**

▲ WARNING

Cancer and Reproductive Harm
www.P65Warnings.ca.gov

D960

Operating, servicing and maintaining this equipment can expose you to chemicals including gasoline, diesel fuel, lubricants, petroleum products, engine exhaust, carbon monoxide, and phthalates, which are known to the State of California to cause cancer and birth defects or other reproductive harm. To minimize exposure, avoid breathing exhaust, do not idle the engine except as necessary, service your vehicle in a well-ventilated area and wear gloves or wash your hands frequently when servicing your vehicle. Battery posts, terminals and related accessories contain lead and lead compounds, chemicals known to the state of California to cause cancer, birth defects or other reproductive harm. For more information go to www.P65Warnings.ca.gov. This website, operated by California's Office of Environmental Health Hazard Assessment, provides information about these chemicals and how individuals may be exposed to them.

Magnum 190 / 225 / 245 / 270 Series Medium Duty Mowers

This manual covers the Medium Duty Magnum series of flail mowers which are available in 1.9m, 2.25m, 2.45m and 2.7m cut widths.

They are all fitted with a hydraulic ram which provides 430mm of side-shift.

These medium-duty machines can be front, or rear mounted by decoupling and reversing the hitch which provides added functionality at no extra cost.

In order to cater for the front and rear mounting options, these machines can be run at 540rpm or 1000rpm. Providing the tractor front and rear drive rotation is consistent with the machine drive rotation, the two drive speeds can be achieved by swapping the drive pulleys over.

It is essential that the guards (including the roller) are always fitted during operation and that the machine is operated in line with the procedures and practices detailed in this manual.

IMPORTANT

This operator's manual should be regarded as part of the machine. Suppliers of both new and second-hand machines are advised to retain documentary evidence that this manual was provided with the machine.

This machine is designed solely for ground vegetation control and must not be used for any other purpose. Use in any other way is considered as contrary to the intended use. Compliance with, and strict adherence to, the conditions of operation, service, and repair, as specified by the manufacturer, also constitute essential elements of the intended use.

This machine should be operated, serviced, and repaired only by persons who are familiar with its characteristics and who are acquainted with the relevant safety procedures.

Accident prevention regulations, all other generally recognised regulations on safety and occupational medicine, and all road traffic regulations must always be observed.

Any arbitrary modifications carried out to this machine may relieve the manufacturer of liability for any resulting damage or injury.

It is potentially hazardous to fit or use any parts other than Genuine McConnel Parts.

The company disclaims all liability for the consequences of such use which, in addition, voids the machine warranty.

Contents List

1	Machine Description	3
1.1	Intended usage	3
1.2	General arrangement	4
1.3	Rotation Definitions and conventions	4
1.4	Machine general specification.	5
1.5	Other model specific information.	7
1.5.1	Reversing the headstock for front mount operation:.....	8
2	Safety	9
2.1	Safety warnings;	9
2.2	Stopping in an Emergency	11
2.3	Noise	11
2.4	Personal Protective Equipment	11
2.5	Guards	11
2.5.1	Mandatory guards.....	12
2.6	Tractor stability.....	12
2.7	Working on inclined ground	12
2.8	Working on embankments	13
3	Safety Decals	14
4	Machine preparation	16
4.1	Tractor requirements;	16
4.2	Tractor checks	16
4.3	Lifting the machine	16
4.4	Tractor preparation for mounting headstock:	16
4.4.1	Mounting the Medium Duty Magnum range.....	17
4.6	Fitting the PTO.....	18
4.6.1	Shortening the PTO length	18
5	Gearbox oils and Grease	19
5.1	Filling the Gearbox	19
5.2	Filling the Drive tube	19
5.3	Greasing points.....	19
6	Settings and adjustments	20
6.1	Operational settings and adjustments	20
6.1.1	Adjusting the height of cut.....	20
6.1.2	Settings for flail mower 'float'	20
6.1.3	Hydraulic side shift: (Where fitted).....	21
6.1.4	Flail types available	22
6.1.5	Tensioning of drive belts	22
6.1.6	Adjusting the roller scraper	23
7	General operation	24
7.1	Operator training.....	24
7.2	Machine Inspection records:	24
7.3	In the maintenance tool box: (Not supplied)	24
7.4	Basic control	25
7.4.1	Machine pre-start check.....	25
7.4.2	Start up:.....	25
7.4.3	Stopping:	25
7.4.4	Transportation to or from work site	25
7.5	Cutting guidelines	26
7.5.1	The Tractor.....	26
7.5.2	The work area.....	26
7.5.3	General cutting hints.....	26
7.5.4	Stalling the rotor.....	26
8	Removal, Storage and Disposal	27
8.1	Preparation for storage.....	27
8.2	Parking and removal	27
8.3	Disposal	28

9	Maintenance	29
9.1	Regular preventative maintenance:.....	29
9.2	Drive components.....	29
	9.2.1 Power-Take-Off shaft (PTO).....	29
	9.2.3 Gearbox	30
	9.2.4 Rotor shaft.....	31
	9.2.5 Flail replacement	31
9.3	Hydraulic components (if fitted)	32
	9.3.1 Rams.....	32
	9.3.2 Filter(s)	32
	9.3.3 Hoses	32
9.4	Structural components	33
	9.4.1 Pins.....	33
	9.4.2 Greasing.....	33
10	Trouble shooting	34

1 Machine Description

1.1 Intended usage.

The Medium-duty Magnum series of flail mowers was developed for farmers or small-scale contractors and is popular with local authorities. They can be used to cut grass margins, paddocks, general maintenance and scrub areas.

The Medium-duty Magnum series of flail mowers are designed for use on level, undulating or inclined ground and for a duty cycle of 200hours per annum. They will cut vegetation up to 50mm thickness.

They can be mounted to agricultural tractors with a minimum of 45-75Hp and weighing at least 2000kg dependant on the machine cutting width.

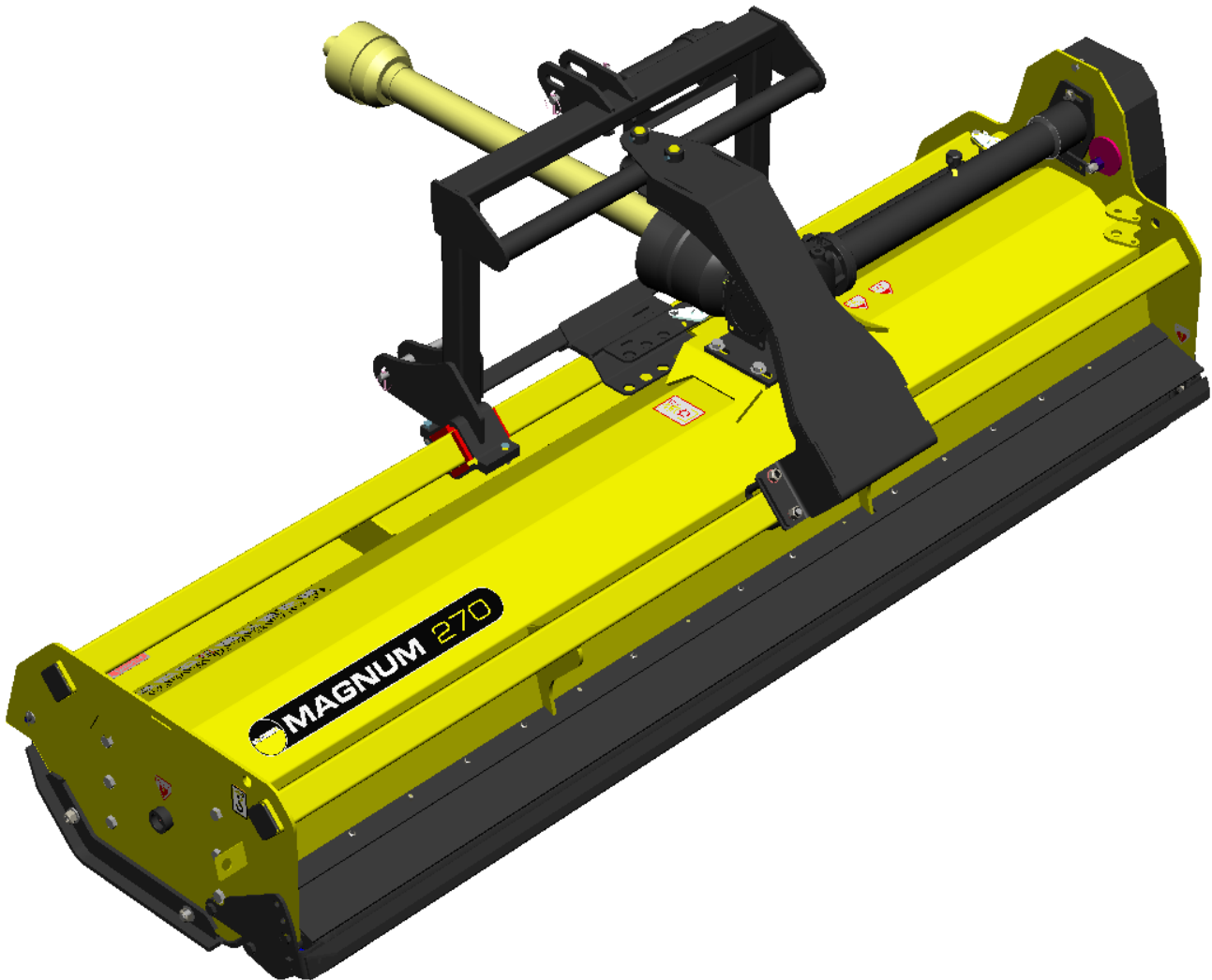

Figure 1.1 McConnell Magnum
(270 model illustrated)

1.2 General arrangement

The layout and naming convention used throughout this manual are shown in Figure 1.2 below

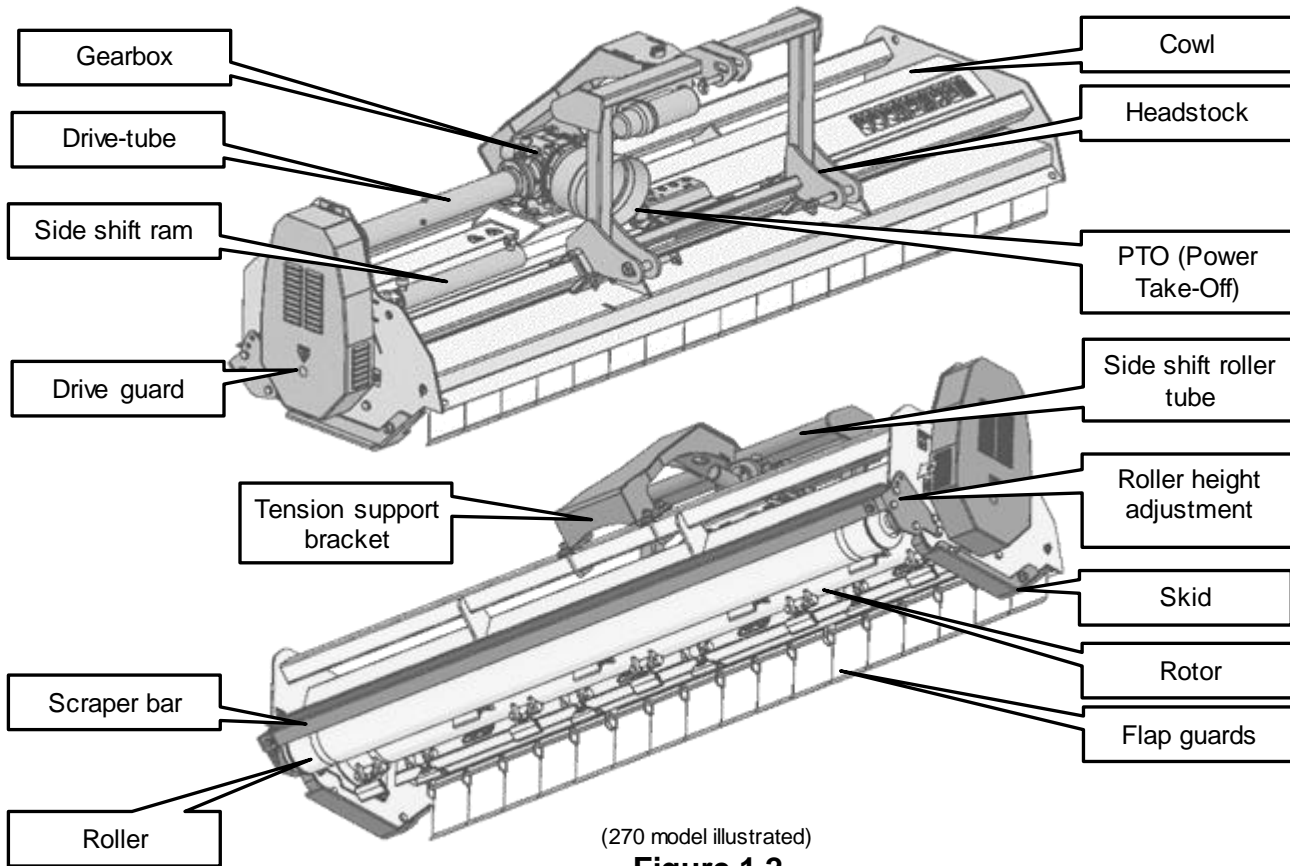

Figure 1.2

1.3 Rotation Definitions and conventions

This instruction manual refers to relative rotational directions. The terms clockwise and anti-clockwise are relative definitions and depend on the operator's viewpoint. To eliminate confusion the following definitions will be used throughout this text;

Under normal cutting conditions flail rotation in the flail mower will be the reverse of the tractor drive wheel rotation. This will be defined as '**Reverse rotation**' (RR). See Figure 1.3 (A).

[**Note:** for information only; When the direction of flail rotation in the flail mower is the same as the tractor drive wheel rotation, this is defined as '**Forward rotation**' (FR)]

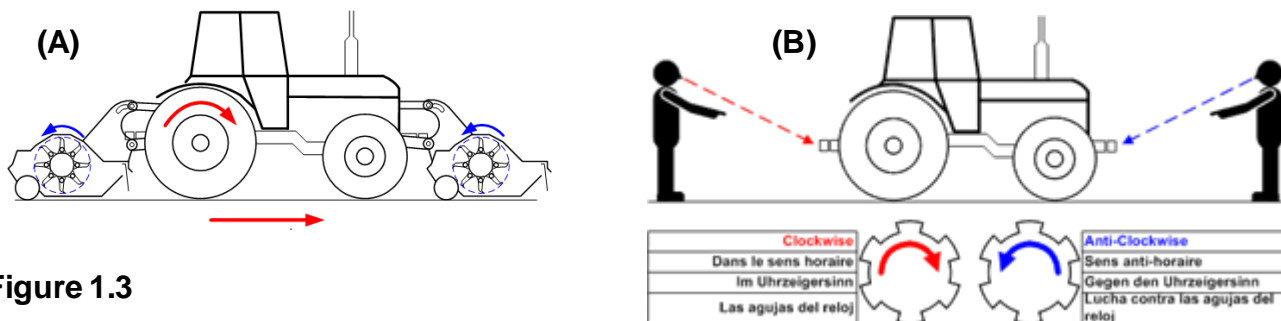

Figure 1.3

Additionally, other references to 'clockwise' and 'anti-clockwise' actions by the operator conform to international right-hand thread conventions for 'screw down' and 'un-screw' respectively.

This convention also extends to the definition of PTO drive rotation from the prime mover, see Figure 1.3 (B).

1.4 Machine general specification.

Medium Duty Magnum (1)		MD 190	MD 225	MD 245	MD 270
Tractor	Horsepower	45-60	55-75	65-90	75-100
	Weight	2000kg			
PTO	Type	Live			
	Speed	540/1000rpm (+/-5%)			
	Size	34.9mm (1 3/8inch), 6 spline			
Gearbox	Capacity	1.5Litres			
Ram	Stroke	430mm (17")	430mm (17")	430mm (17")	430mm (17")
Mower	Mass (From CAD)	620kg	716kg	747kg	795kg
Dimensions (1) (6)	Overall Width	2139mm (84")	2443mm (96")	2629mm (104")	2895mm (114")
	Cutting width	1868mm (74")	2172mm (86")	2324mm (92")	2628mm (104")
	Overall length (Behind the tractor)	1001mm (39")			
	Height to top link pin	1040mm (41")			
	Full offset (to centreline) (2)	1383mm (54")	1583mm (62")	1717mm (68")	1931mm (76")
	Max. Transport half width (3)	1186mm (47")	1290mm (51")	1342mm (53")	1501mm (59")
	Transport overhang (4)	1758mm (69")			
Drive	Rotor Drive	V Belt	V Belt	V Belt	V Belt
	Number of drive belts	3	3	3	3
Shaft speed	Nominal shaft output speed (rpm) [540rpm PTO / 1000rpm PTO.]	2147 / 2264	2147 / 2264	2147 / 2264	2147 / 2264
Flail type	Whale tail (120mm) (Quantity)	24	28	30	34
Cut height	Min (mm)	40mm (1.6")	40mm (1.6")	40mm (1.6")	40mm (1.6")
	Max (mm)	90mm (3.5")	90mm (3.5")	90mm (3.5")	90mm (3.5")

Notes:

- (1) McConnel constantly reviews and improves product designs and reserve the right to change this information. Actual machines may vary from the above specification. Contact your McConnel Sales representative if you have any queries.
- (2) The 'full offset to centreline' dimension is the larger offset to centreline when the side shift ram is fully retracted. The actual deployment distance beyond the tractor wheel is dependent on tractor width and machine transport symmetry.
- (3) When the side shift ram is fully open the machine is ready for transporting. In this position the machine centreline may not be in line with the tractor centreline. The 'transport width to centreline' is the corresponding larger half-width dimension for a machine which sits asymmetrically with respect to the tractor centreline. The largest half width may be drive or non-drive end and not necessarily as illustrated in Figure 1.5. Without taking special precautions, the maximum permissible transport width on public roads is 2.55m.
- (4) The transport overhang is indicative and will vary with the specified tractor. This figure assumes a reference dimension of 757mm (30") between rear axle centre and mower rotor centre.
- (5) Figures quoted for shaft rpm are dependent on the pulley configuration.
- (6) All dimensions are determined from computer models, so actual measurements may vary slightly.

The following figures for Reach dimensions, Transport position and Shipping position illustrate the Magnum 270 only.

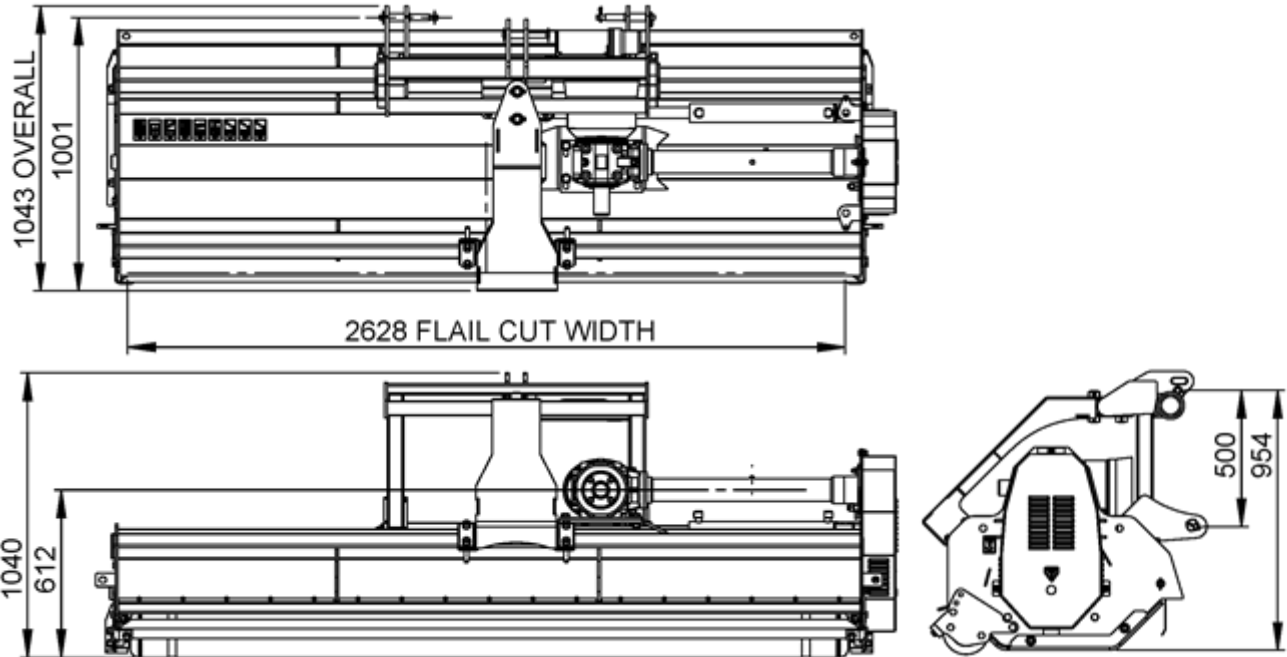

Figure 1.4 Reach dimensions

NOTE: These figures for Reach dimensions, Transport position and Shipping position illustrate the Magnum 270 only

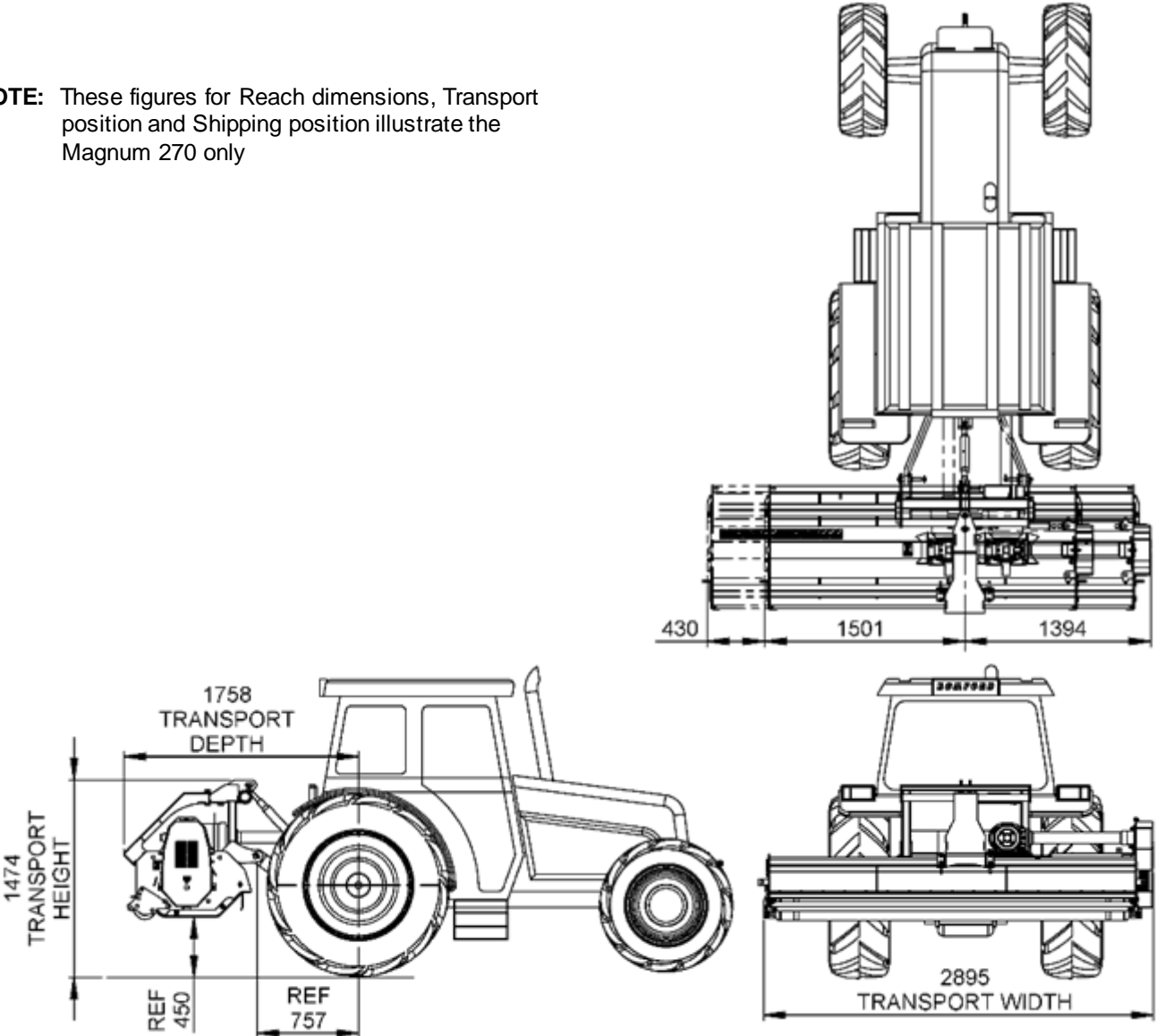
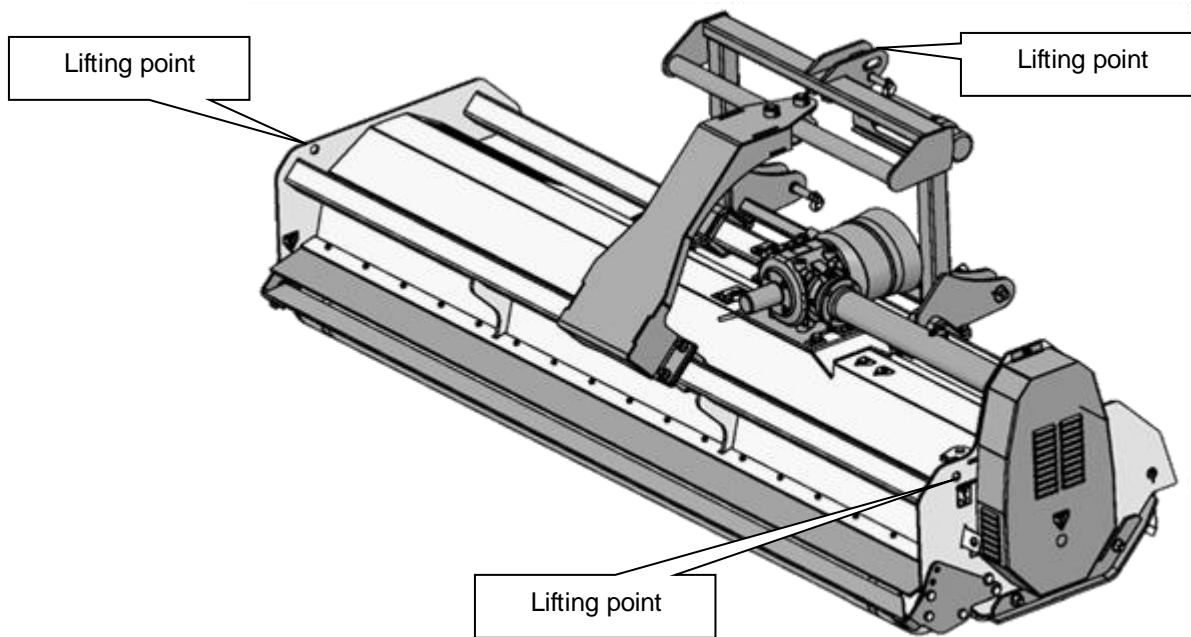

Figure 1.5 Transport position



WARNING! Do not lift by Headstock or drive tube alone. Damage may occur which will invalidate warranty.

Figure 1.6 Shipping position

1.5 Other model specific information.

Although the medium-duty Magnum series of flail mowers are rear mount as built, it is possible to turn them into front mount machines by reversing the headstock. See Figure 1.7

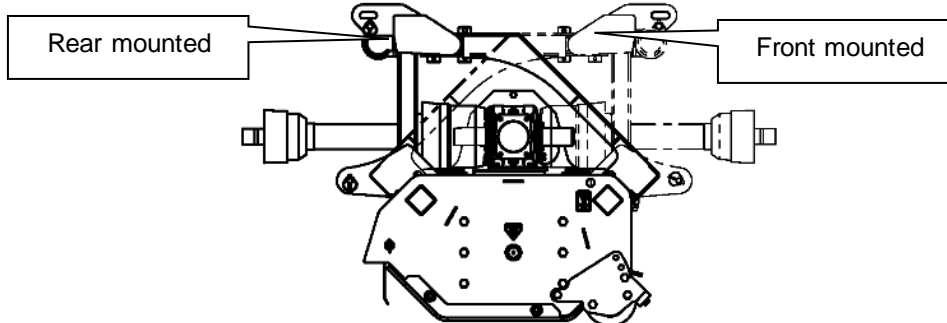

Figure 1.7

IMPORTANT! Before investing time in reversing the headstock, check that the rotation direction of the tractor front output is opposite that of the tractor rear output. (**Note:** Rotation direction is defined by the McConel PTO rotation convention, see section 1.3). Failure to check this first, may produce no rotor motion when changed because the gearbox overrun operates.

1.5.1 Reversing the headstock for front mount operation:

- 1.5.1.1 Ensure that the machine is de-mounted from the tractor and standing on firm level ground within reach of lifting equipment.
- 1.5.1.2 The machine is normally supplied configured for rear mount and 1000rpm PTO drive, see Figure 1.8.
- 1.5.1.3 Before disconnecting the stationary 'U' bolts and two sliding clamps measure and record the distance from the Tension support bracket to the drive end plate and also the distance from the nearest Headstock slider to the drive end plate.
- 1.5.1.4 Support the Headstock in readiness to lift the Headstock clear. Be prepared, once disconnected, the Tension support bracket may rotate independently of the headstock due to the sliding roller support that connects them.

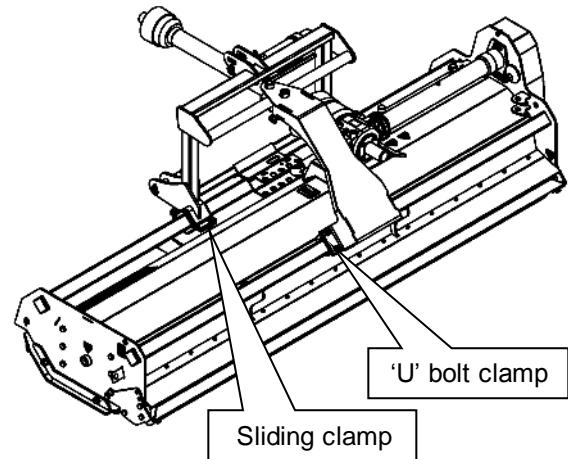

Figure 1.8



WARNING! Only personnel experienced in lift and hoist operation should be involved in lifting machines.

- 1.5.1.5 Undo the 6 setscrews holding the two Headstock slider clamps onto the cowl slide bar.
- 1.5.1.6 Retain the green-plastic linear bushes with each respective slider clamp.
- 1.5.1.7 Undo the 4 setscrews on the 2 'U' bolts holding the Tension support bracket to the cowl slide bar.
- 1.5.1.8 Lift the complete headstock and Tension support bracket assembly clear of the machine taking care to prevent the Tension support bracket swinging freely and causing impact damage.
- 1.5.1.9 Retain the two green-plastic linear bushes taking note to relate them to the same Headstock support point.
- 1.5.1.10 Rotate the assembly through 180 degrees.

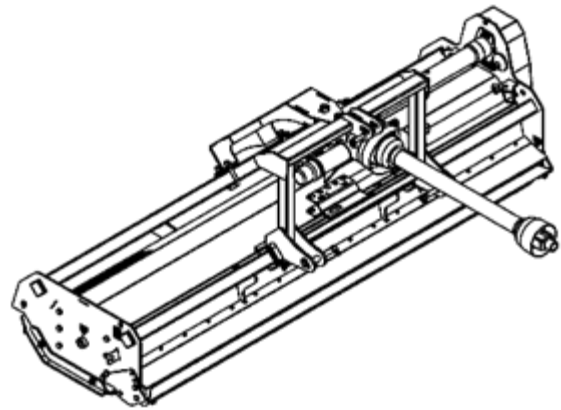

Figure 1.9

- 1.5.1.11 Lower the assembly with care to re-engage the Headstock sliders onto the cowl's rear slider bar. Ensure the appropriate green-plastic linear bushes are inserted before the Headstock contacts the slider bar. Throughout this operation, take care to support the free hanging Tension support bracket, keeping it raised above the cowl. Do not lower the assembly weight fully onto the slider bar.
- 1.5.1.12 Manually rotate and align the Tension support bracket onto the cowl's front slider bar.
- 1.5.1.13 If necessary, whilst the assembly is still supported, slide the assembly left or right to ensure that the measurements from the cowl drive end plate to the Headstock and Tension support bracket are the same as recorded earlier.
- 1.5.1.14 Re-fasten all 'U' bolts, locking the Tension support bracket in place.
- 1.5.1.15 Re-fit the green-plastic linear bushes into the slider clamps and re-fasten. Take care not to overtighten as the headstock must slide on the bushes.
- 1.5.1.16 Remove the lifting aid(s)
- 1.5.1.17 Finally unfasten the Gearbox PTO guard and the opposing Gearbox Pinion cover, swap them over and re-fasten them to the Gearbox.
- 1.5.1.18 The machine is now ready for front mounting, see Figure 1.9.

2 Safety:

2.1 Safety warnings;

The operator must read, understand and follow all of the Safety instructions. Serious injury or death may occur unless care is taken to follow the warnings and instructions provided. The level of safety is indicated in three levels and the following notation is used throughout this operator instruction book;



DANGER! Level 1; alerts for imminent death or critical injury.



WARNING! Level 2; warns of serious injury or possible death.



CAUTION! Level 3; indicates possible injury.

Never operate the tractor or machinery until you have read and completely understood this manual and the tractor operator's manual and each of the safety messages found in the manuals and those displayed on the tractor and implement.



DANGER! It is required that all operators and personnel carrying out maintenance on this machine familiarise themselves with the machine and this operator manual to ensure they are aware of the dangers of incorrect use or improper or incorrect repairs.



DANGER! **DO NOT** attempt any maintenance of or adjustment to the machine while it is running. Before carrying out any work on the machine follow the four safety instructions below:

1. Lower the cutting head on to the ground
2. Put the PTO out of gear
3. Apply the hand brake and if the ground is sloping, wedge the tractor securely
4. Stop the tractor engine, remove and pocket the starting key.



DANGER! Before starting, safety checks on tractor and flail mower must be carried out with regard to: functionality, road safety and accident prevention rules.



DANGER! The condition of flails and all guards must be checked before beginning daily work – they must be replaced if damaged or missing.



DANGER! At all times ensure that the PTO shaft guard is in position, securely fitted and in good condition and that the tractor PTO shaft shield is fitted.



DANGER! Keep a careful watch for passers-by who may inadvertently get in the way of cut material being thrown from the flail mower. Flail mowers are capable under adverse conditions of throwing objects great distances at high velocity. Stop the rotor shaft until all people are well clear.



DANGER! Do not use the machine when there is vibration in the flail mower, as this would cause breakage and serious damage. Find the cause of the vibration and eliminate it.



DANGER! **AVOID WIRE.** It can be extremely dangerous if wire catches in the rotor, and every care must be taken to ensure this will not happen. Inspect the working area before commencing. Remove all loose wire and obstructions and clearly mark those that are fixed so that you can avoid them. Any unusual noise from the cutting unit area indicates that the rotor shaft may have been fouled by an obstruction. In any such event **STOP** the tractor engine **INSTANTLY**. On no account move the cutting unit until the rotor has completely stopped. **NEVER UNDER ANY CIRCUMSTANCES** run the rotor in reverse to 'clear itself'. When the rotor has stopped, inspect it and remove any obstruction that may be present. If working under a raised machine ensure that it is safely supported. Before working on the rotor always stop the tractor engine and remove the ignition key.



DANGER! Pay special attention when working with the machine and do not to touch fixed objects such as road drains, walls, shafts, curbs, guard rails, tracks etc. as these could break the flails which could cause debris to be thrown at very high speed from the machine



DANGER! Flail mowers are capable under adverse conditions of throwing objects great distances at high velocity. CHECK the flails for wear and the attachment bolts for tightness every day during work. A few moments; whenever the machine is stopped (e.g. whenever removing obstructions); will help reduce flail wear or loss.



DANGER! Keep your forward speed to a level appropriate to the operating conditions. High-speed manoeuvres are very dangerous, particularly on uneven ground where there is risk of overturning.



DANGER! Where a flail mower is used in conjunction with tractors not fitted with a glazed safety cab, a clear polycarbonate safety screen together with a mesh guard must be fitted to the tractor between the operator and the cutting unit. A polycarbonate safety screen must be used on cabs where windows are likely to be left open for ventilation purposes. It is essential that cab windows on the operating side; through which the cutting head is observed; are intact, clean and closed, or a clear polycarbonate safety screen must be fitted where grass trimming operations are carried out.



WARNING! McConnel flail mowers have not been designed to carry towing forces. Owners or operators that fit tow hooks to McConnel machines with the intention of towing or hauling do so at their own risk.



WARNING! Do not operate machinery with guards missing. Ensure that the correct guards are properly fitted to the machine and tractor at all times and that they are in good condition. Refer to section 2.5 to ensure you have the correct guards fitted.



WARNING! While the tractor is running all personnel should keep well clear of the area around the machine as there are numerous crushing, shearing, impact dangers caused by the machine operation.



WARNING! Extreme care should be taken when operating near loose objects such as gravel, rocks, wire, and other debris. Inspect the area before mowing. Foreign objects should be removed from the site to prevent machine damage and/or bodily injury or even death. Any objects that cannot be removed must be clearly marked and carefully avoided by the operator. Stop mowing immediately if flails strike a foreign object. Repair all damage and make certain the rotor shaft is still balanced before resuming cutting operations.



WARNING! Transport the machine only at safe speeds. Serious accidents and injuries can result from operating or transporting this equipment at unsafe speeds.



WARNING! Failure to have sufficient load over the front axle or to drive at inappropriate speeds on undulating terrain may result in a loss of directional control.



WARNING! Check that the levers which operate the hydraulic lift are locked into position, to avoid the machine lowering during transport.



WARNING! When driving on public roads respect other road users and obey the Highway Code.



WARNING! Never transport the machine with the rotor moving, even for short distances



WARNING! When operating the machine do not wear loose or trailing clothing which may become snagged or entangled in moving parts.



WARNING! Never carry passengers on the tractor.



WARNING! Never carry passengers on the flail mower.



WARNING! Never connect the power takeoff unless the engine is stopped.



WARNING! Never approach the flail mower until the rotor has completely stopped.



WARNING! Do not enter the working zone of the PTO shaft. It is dangerous to approach the rotating parts of the machine.



WARNING! Immediately replace any missing safety sign or any missing or damaged decal



CAUTION! Replace the PTO shaft guard or PTO coupling guard if any of the following are evident; guard cracked or damaged, any part of the PTO shaft exposed. Ensure the PTO shaft guard is free to rotate and the anti-rotation chains are securely fitted and effective.



CAUTION! Keep the roller in position at all times. It is an essential part of the machines guarding. The machine must not be operated with the roller missing.

2.2 Stopping in an Emergency

In an emergency use the prime mover controls to disengage drive to the PTO.



DANGER! **Be aware:** The flail mower is fitted with an overrun clutch. This means that even when drive is disengaged from the PTO the rotor shaft will continue to rotate under its own inertia for some time

2.3 Noise

The sound level of this machine, as measured at the operator's ear, ranges from 74 dB to 75,8 dB when the cab is closed and from 77,3 to 81,2 dB when the rear window is open. The acoustic power level is LWA 101,2. When the sound level perceivable at the operator's ear ranges from 85 to 90 dB, the use of ear protectors is recommended.

2.4 Personal Protective Equipment

When working in an unsealed cab or where windows and apertures are open to the environment, operators are advised to wear suitable ear protectors, see section 2.3.

When handling cutting surfaces or hydraulic equipment, operators are advised to wear suitable gloves.

When clearing blockages, clearing wire, or working with pressurised hydraulic components, operators are advised to wear suitable eye protection.

When working at the work site, but off the tractor unit, operators are advised to wear a 'high-viz' garment.

2.5 Guards



DANGER! For safe operation it is essential that that all guards and the roller must be kept in position on the machine whenever the machine is running. McConnel Ltd disclaim all responsibility for any damage or injury arising as a result of guards or roller being removed, or of guards other than of McConnel manufacture having been fitted, or of operation of the machine other than in accordance with these instructions.



WARNING! Inspect guards twice daily or immediately damage is suspected.

Always replace guards that have damage or wear which could impair their performance. Typical damage to inspect for is as follows;

- **Drive guard and side skids** - distorted or with sharp outer edges.
- **PTO guards** - cracked, missing portions revealing moving parts
- **Flexible front guards** - missing portions, damaged, or worn sufficiently to permit stones or similar objects to be ejected beneath it in normal conditions.

2.5.1 Mandatory guards

The General arrangement figure in section 1 and the list below show the mandatory guards required. These along with the Danger decals and Warning decals are necessary for safe cutting operations with this flail mower;

- PTO coupling guard
- PTO shaft guard
- Drive belt guard
- Front metal flap guards
- Side guard skids
- Rear rubber flap (Where fitted)
- Rear adjustable guard (Where fitted)
- Roller

2.6 Tractor stability

To eliminate any risk of loss of directional control, imbalance or overturning, it is essential that the tractor is stable during work and transport.

If the flail mower has 'side-shift' or 'offset' capability then, before work, check that at the flail mowers furthest side-shift the rear wheel on the opposite side to the side-shift is still on the ground. It is advisable to have a helper to check this. Check that the tyre shows evidence of bearing some load.

If the tyre lifts, then add ballast in the form of wheel weights to the rear wheel of the tractor opposite to the mower movement until the tyre shows evidence of bearing some load.

Before driving in transport, place the flail mower in the transport position and again check that the front wheels of the tractor are both on the ground. Again, it is advisable to have a helper to check this. Check that the tyre shows evidence of bearing load. This is especially important to ensure forward directional control at speed on undulating terrain.

If the front tyres lift, add ballast weights to the front of the tractor. If ballast weights have been added to the tractor, check that the plated tractor axle loads have not been exceeded.



WARNING! Failure to have sufficient load over the front axle or to drive at inappropriate speeds on undulating terrain may result in a loss of directional control.

IMPORTANT: When transporting on the highway, it is the responsibility of the operator to obey all relevant local highway laws.

2.7 Working on inclined ground

The ballast instructions in section 2.6 are sufficient for level ground operation.

Be aware that when working on inclined ground changes in the tractor centre of gravity can adversely affect the overall stability. If the flail mower is side shifted and deployed downhill additional ballast may be required on the rear offside wheel to compensate. This is particularly true when raising the implement whilst turning.

There is naturally a limit to a safe amount of ballast compensation that can be applied for a given tractor unit and a given incline. If compensating ballast is applied and the compensated axle must be driven on the public highway to reach the work site the operator should ensure that the plated axle load is not exceeded.

Remember, a flail mower represents a significant mass which can generate a significant amount of inertia when moved at speed. Stopping this inertia suddenly can induce overturning reactions.



DANGER! When working on inclined ground avoid high speed manoeuvres which could cause overturning.

2.8 Working on embankments

Sudden potholes at speed can quickly cause the tractor to change direction. At the same time the weight of the implement may try to lift the front axle. This is a potentially lethal combination when working along narrow embankments or dykes and can lead to overturning and potential drowning.

When working on top of embankments it is very important to have sufficient forward stability to ensure rapid steering control. McConnell recommend 20% forward stability. This means that at least 20% of the total vehicle weight is acting on the steering axle under normal level conditions.



DANGER! When working on raised embankments ensure sufficient weight is on the steering wheels.

3 Safety Decals

Safety decals are located on various points of the machine see Figure 3.1. They can be identified by the yellow upper panel depicting the hazard, and the lower white panel indicating means of avoidance or precautions to be taken. These decals have no text. It is essential that all operators and personnel associated with the machine fully understand their meanings, which are shown in Figure 3.2.

Safety decals should be kept clean and legible at all times. Any safety decals which are found to be missing or illegible should be replaced.

Item No.	Decal Description	Quantity
1	Instruction: - Grease every 8 hours	4
2	Instruction: - PTO input speed requirement	1
3	Warning: - Driveline missing	1
4	Instruction: - 350kg lifting point	1
5	Instruction: - Oil filler location	1
6	Instruction: - Oil level location	1
7	Danger: - Safety zone keep out	2
7	Warning: - Read instruction manual	1
7	Warning: - Turn off engine and remove key	1
7	Warning: - Keep nuts tight	1
7	Danger: - Crushing hazard if unsupported	1
7	Danger: - Thrown objects hazard	1
7	Danger: - Shaft entanglement hazard	1
7	Danger: - Cutting hazard from rotating blades	1
7	Danger: - Pinch point hazard	1

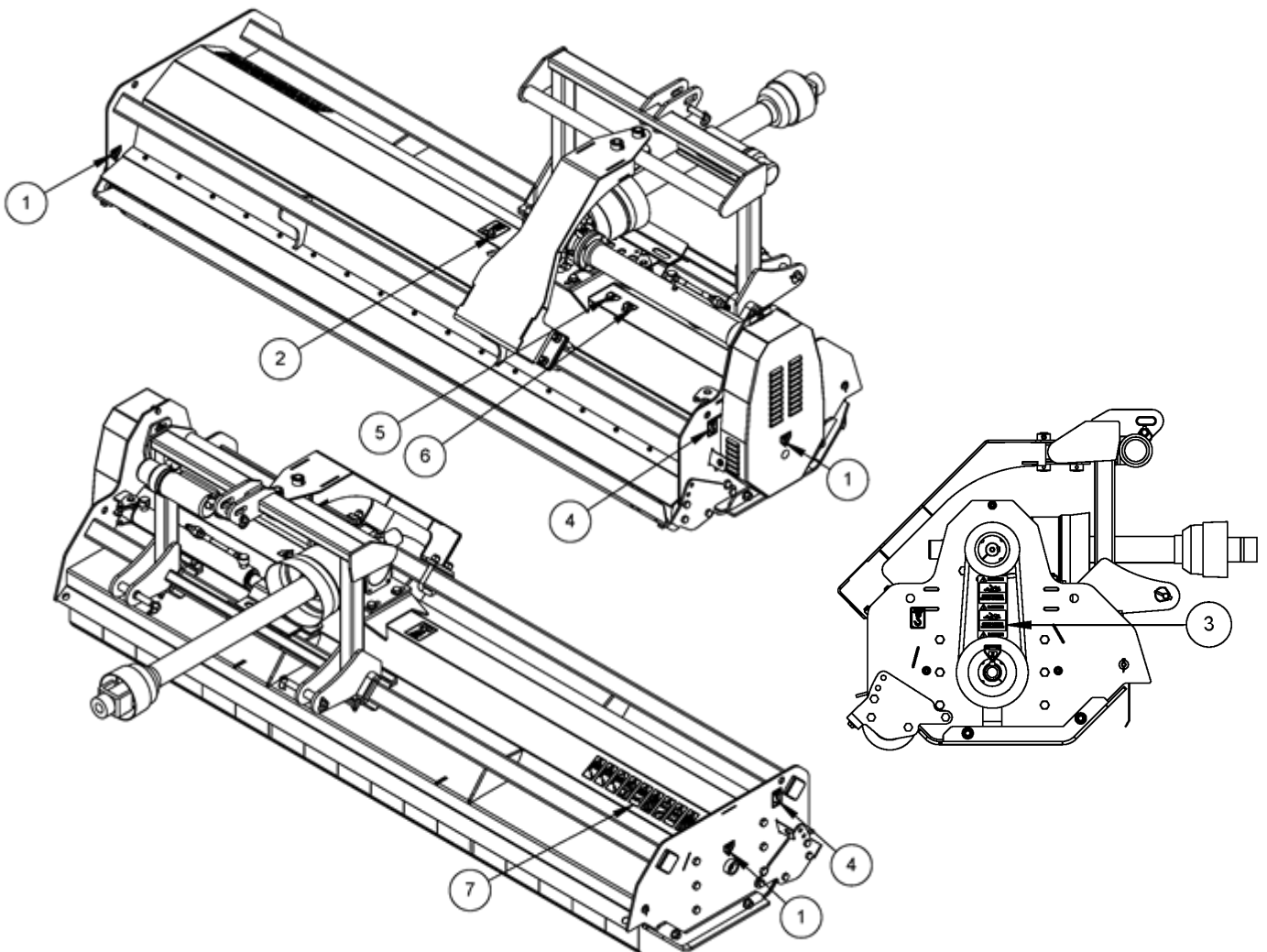

Figure 3.1



Figure 3.2

4 Machine preparation

4.1 Tractor requirements;

Before fitting the machine to the tractor ensure that specification of the tractor meets the requirements listed below.

4.2 Tractor checks

- 4.2.1.1 Availability of a PTO output shaft which conforms to the 'Machine general specification' in chapter 1.0.
- 4.2.1.2 Availability of a PTO output speed which conforms to the 'Machine general specification' in chapter 1.0.
- 4.2.1.3 A tractor top link is available if required.
- 4.2.1.4 To ensure fore aft stability ballast may need be added to the tractor front weight tray. The amount will vary depending on type of tractor used and prevailing conditions.
- 4.2.1.5 To ensure lateral stability ballast may need to be added to the rear wheel opposite the side shift or offset direction. The amount will vary depending on type of tractor used and prevailing conditions. NOTE: Some McConnell machines are capable of being deployed on both sides of the tractor, in such case lateral ballast may be required on both rear wheels.
- 4.2.1.6 Once the machine is mounted to the tractor and the tractor is correctly ballasted ensure that the maximum axle loads for the tractor have not been exceeded. Failure to meet this requirement may render the operator liable for infringement of public highway regulations.
- 4.2.1.7 Ensure that the tyres fitted to the tractor are correctly rated for the total working weight. NOTE: When the flail mower is side-shifted or offset to its maximum capability the load on the rear tyre on the cutting side increases significantly.
- 4.2.1.8 McConnell does not endorse the use of water ballast within tyres as this can have adverse effects on fore aft stability at speed.

4.3 Lifting the machine



WARNING! Only personnel experienced in lift and hoist operation should be involved in lifting machines.

The lifting points are indicated in the Machine general specification in chapter 1 'Machine description'. Use lifting equipment suitable for the weight of the machine see section 1.4 Machine general specification for machine mass. - Exercise caution!

4.4 Tractor preparation for mounting headstock:

Before mounting the flail mower to the tractor and whenever the machine is used, always conduct the following:

- Visually check the machine in general for defects
- Check that all guards are fitted and in good condition
- Confirm that all flails and bolts are fitted and in good condition
- Grease the bearings and any other part as indicated in Gearbox oils and Grease section.
- Check tractor PTO speed is correct for the machine see section 1.4.

4.4.1 Mounting the Medium Duty Magnum range

The Medium Duty Turbo-mower Elite range can be front, or rear mounted by reversing the fitment of the entire headstock, see section 1.5.

To detach the flail mower from the tractor, complete the following instructions in reverse. To mount the flail mower to the tractor; refer to Figure 4.1; and proceed as follows;

- 4.4.1.1 Position the machine on a flat, hard surface
- 4.4.1.2 Remove the pins (A) and (D) from the support lugs in the headstock.
- 4.4.1.3 Carefully reverse the tractor so that the ball joint on the lower link arm (B) lines up with the lower link pin engagement hole in the headstock.



DANGER! During reversing do not allow personnel between the tractor and the mower.

- 4.4.1.4 Insert the pins (A) and secure them with the spring clips.
- 4.4.1.5 Fit the top link to the tractor and adjust its length until pin (D) can be fitted. Pin (D) can be fitted to the fixed hole or the pitch float slot as required. See section 'Settings for flail mower 'float''. Secure pins with the spring clips.
- 4.4.1.6 Start the tractor and raise the lift arms until the machine is horizontal to the ground.
- 4.4.1.7 Fit and adjust any lateral stabilizer chains or brackets to retain the flail mower to the tractor in a central lateral position.
- 4.4.1.8 Lower the machine to the ground ensuring the lift arms are in float condition before proceeding to fit the PTO (C).

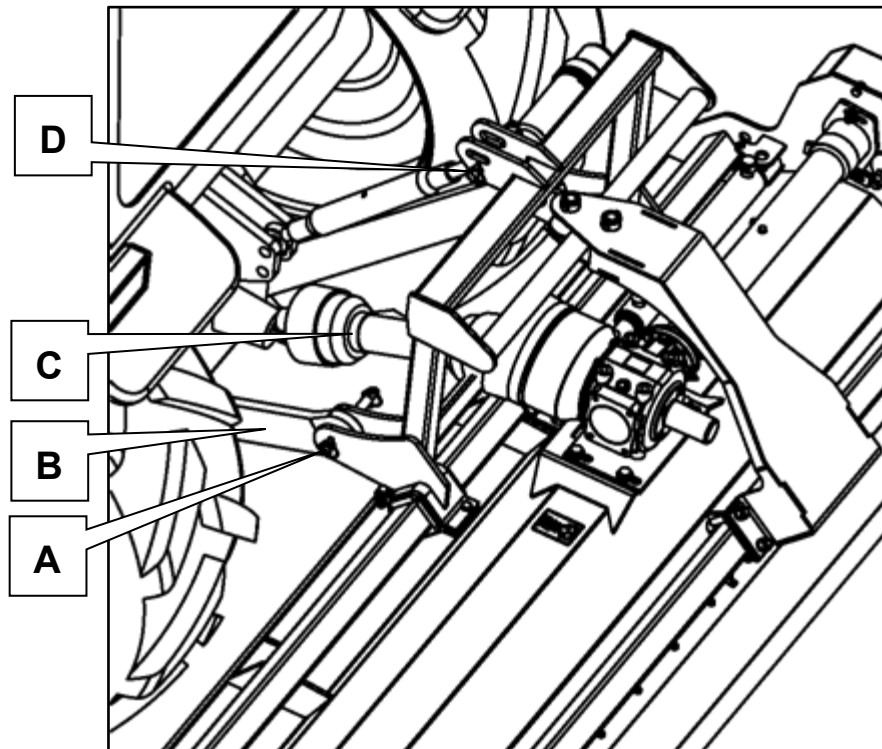

Figure 4.1

4.6 Fitting the PTO

Due to many different makes and sizes of tractor to which mowers may be fitted, a nominal length PTO shaft is supplied with the machine. In some cases, the nominal PTO shaft supplied will be too long and will have to be shortened, see below.

IMPORTANT: The recommended minimum engagement of the PTO is 150mm in the working position. This measurement must be taken into account when shortening the PTO shaft. (See Figure 4.3)

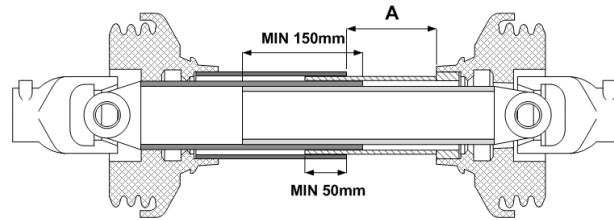

Figure 4.2

4.6.1 Shortening the PTO length

4.6.1.1 Both machinery and tractor must be parallel to one another.

4.6.1.2 Pre-assemble the PTO shaft and check that the drive tube overlap is not less than 150mm, see Figure 4.2 and Figure 4.3 a.

4.6.1.3 Check that the minimum overlap of the shaft guards is not less than 50mm, see Figure 4.2.

4.6.1.4 If the overall PTO length is likely to reduce during operation then ensure that at its minimum there is at least 40mm movement left between the guards, see dimension 'A' in Figure 4.2.

4.6.1.5 If the PTO needs to be shortened, cut both tubes as both halves must be shortened equally, see Figure 4.3 b.

4.6.1.6 Remove burrs with a file and clean any residual cutting debris from the tubes.

4.6.1.7 Before fitting the PTO shaft to the tractor, grease the sliding drive shafts and bearing units.

4.6.1.8 Fit the PTO to the tractor ensuring that the locking peg and collar on the spline-coupling is fully engaged.

4.6.1.9 Attach the PTO guard check chains to the tractor and to the machine to prevent guard rotation.

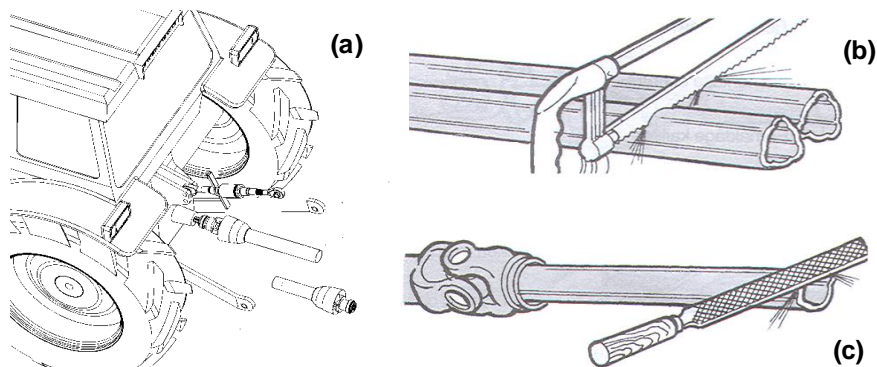

Figure 4.3

5 Gearbox oils and Grease:

5.1 Filling the Gearbox

The gearbox capacity is 1.5 litres. Always check the oil level before use and top up if necessary, see maintenance section. Use oils compatible with classification SAE 90EP (ISO VG 220, AGMA 5EP).

5.2 Filling the Drive tube

The drive tube capacity is 1.1 litres. Always check the oil level before use and top up if necessary, see maintenance section. Use oils compatible with classification SAE 90EP (ISO VG 220, AGMA 5EP).

5.3 Greasing points

See greasing locations in Figure 5.1. Use grease classification DIN 51825 (KP 2 K) or a good quality lithium based grease.

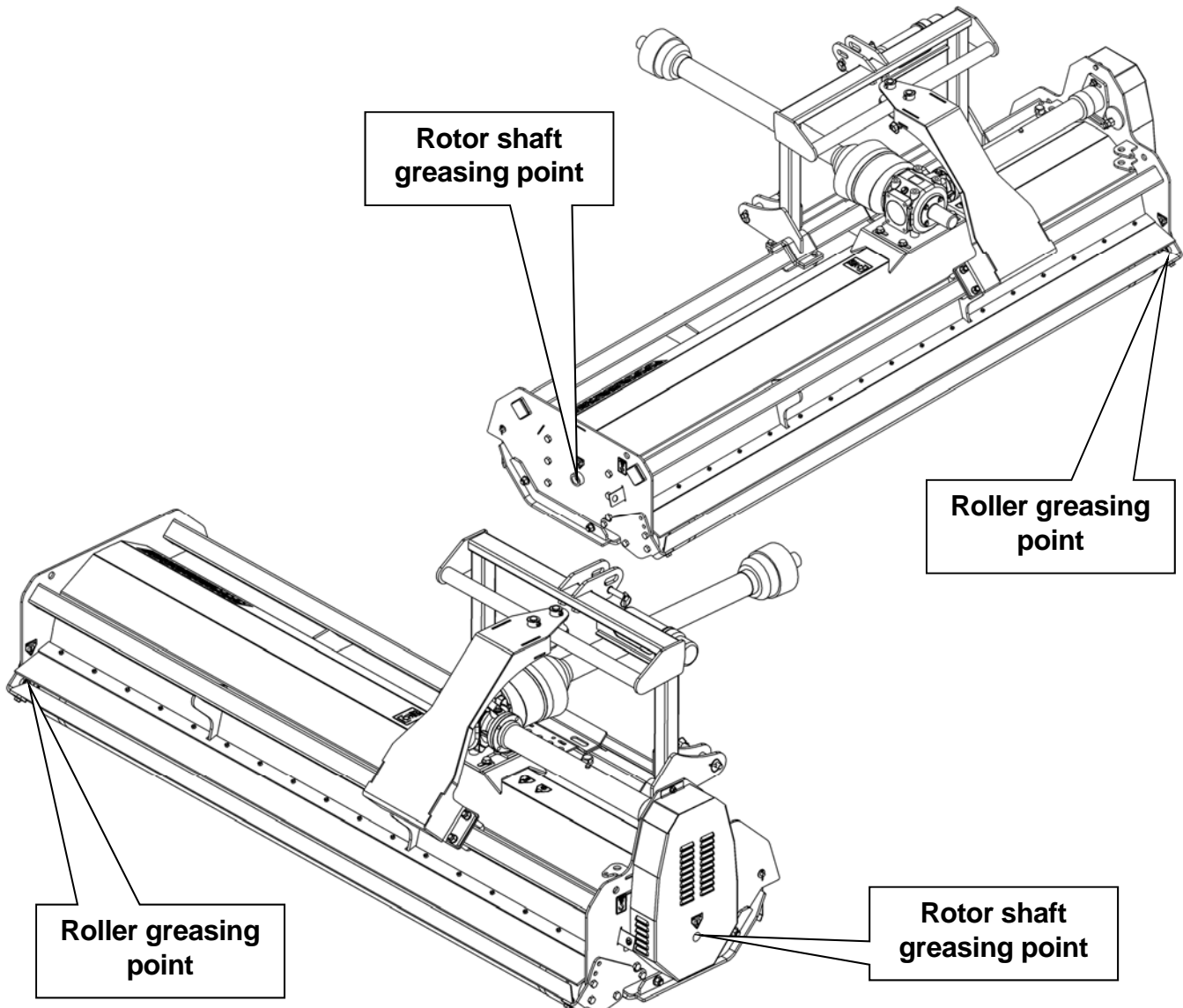

Figure 5.1

6 Settings and adjustments:

6.1 Operational settings and adjustments

6.1.1 Adjusting the height of cut

The cut height can be adjusted by raising or lowering the flail head roller to suit the material to be cut and the required degree of chopping, see Figure 6.1. Support the skids at both ends by blocks. The size of the blocks should be sufficient to give enough free movement of the roller bracket (B) to achieve the desired cut height. Ensure that the machine will not slide off the blocks. Support the roller appropriately - it is heavy! Undo setscrew (A) on the roller bracket at both ends of the machine. Raise or lower the roller to the desired height by aligning one of the roller bracket setscrew holes with the hole in the cowl side plate. Make sure that the same hole is selected at both ends. Failure to do this will produce an uneven cut. With the roller still supported, re-fit and re-tighten the setscrews on both roller brackets. Remove the roller support and the blocks to lower the machine to its new cut height.



CAUTION! Do not allow the rotor flails to contact the ground - set roller height to allow a minimum flail to ground clearance of 1 to 3cm.



CAUTION! The machine must always run on the rear roller not the side skids – side skids are a protection feature and in normal working conditions remain clear of the ground.

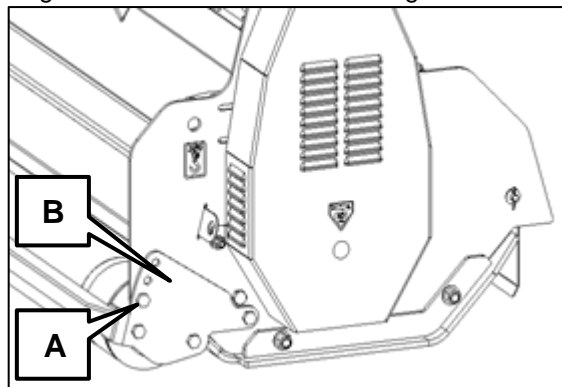

Figure 6.1

6.1.2 Settings for flail mower 'float'

The flail mower top link has two working modes; floating and fixed, see Figure 6.2. To cut and maintain flat level ground; such as playing fields and other similar areas that present a lower degree of stress on the linkage; the operator may wish to fix the flail mower parallel to the tractor footprint with the single fixed upper link hole (B). However, for hilly or uneven terrain; and to protect the machine and linkage from damage; the operator will want a degree of float between the tractor footprint and the undulating ground. This can be achieved through use of the top link mounting slot (A).



CAUTION! To prevent damage always use the top link floating position (when working on hilly, sloping or undulating terrain).

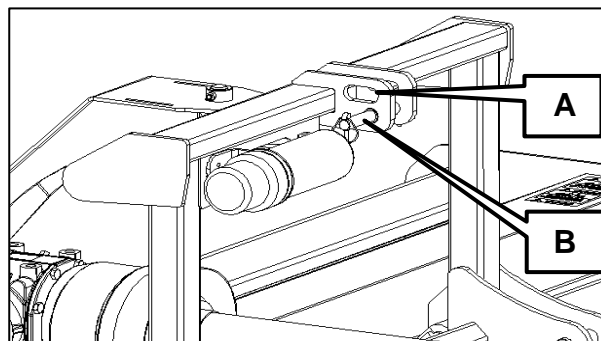

Figure 6.2

When setting the top link for float whilst on flat ground be sure to adjust the top link pin to the middle of the slot to allow for rise and fall. See Figure 6.3

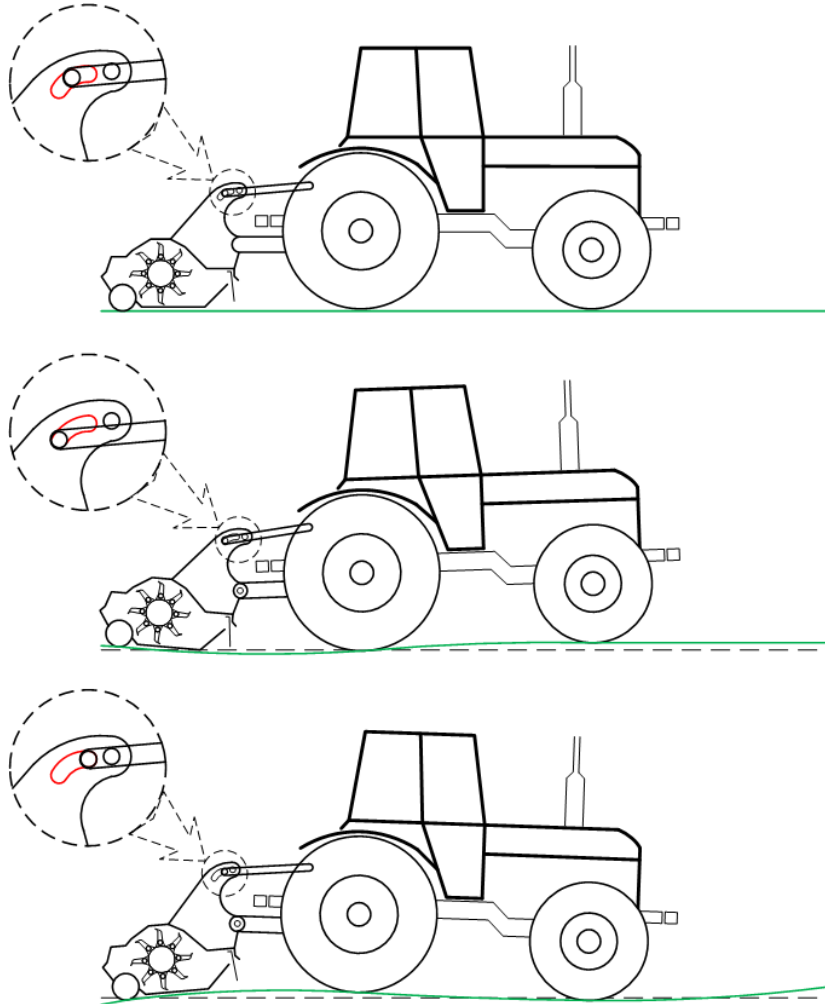

Figure 6.3

6.1.3 Hydraulic side shift: (Where fitted)

On machines fitted with hydraulic side-shift, adjustment to the required side shifted position can be carried out from the tractor cab using the tractor auxiliary controls to operate the hydraulic side-shift ram, see Figure 6.4 A. This is best achieved with the mounted unit raised clear of the ground to allow for free sideways movement.

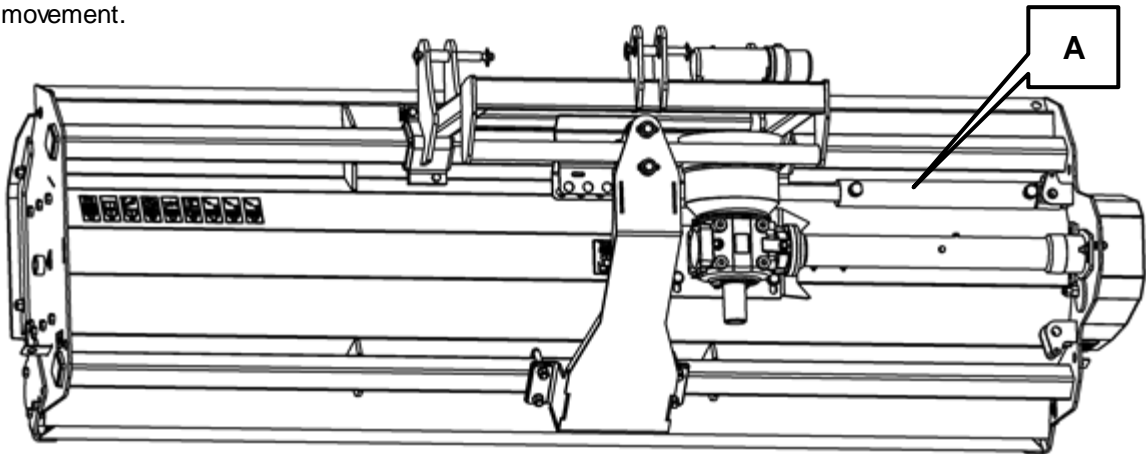

Figure 6.4

6.1.4 Flail types available

The machine is equipped with 120mm Medium 'Whale tail' flails, see Figure 6.5. The Medium 'Whale tail' flails are suited to harder working with the ability to cut materials up to 50mm (2") diameter.

The design of the mower is such that during work the rotor unit cuts in reverse rotation (See section 1.3) and raises the cut material over the rotor towards the back of the cowl. In doing so material falls back into the rotor and is cut again several times until it is small enough to be discharged from the rear of the machine.

The rotor unit should be inspected prior to work on a daily basis to check for damaged or missing flails – always replace damaged or missing flails immediately. Flail bolts should be checked for tightness on a regular basis and re-tightened as required before attempting to use the machine.



Figure 6.5



WARNING! When replacing worn or broken flails, always replace opposing pairs and use a new bolt and locknut with every installation. This minimises rotor out of balance and ensures nut retention.



WARNING! Checking of rotor components should only be carried out with tractors engine switched off, starting key removed and the PTO shaft disconnected. Always 'prop up' the machine using suitable supports before attempting to inspect or work on components underneath it.

6.1.5 Tensioning of drive belts

It is important for both optimal machine performance and long-lasting belt life that belts are correctly tensioned at all times. On the medium-duty Magnum range, the belts must be tensioned manually and re-checked periodically.



WARNING! Checking of belts and drive components should only be carried out with tractors engine switched off, starting key removed and the PTO shaft disconnected. Never attempt to run the machine with the belt guard removed – Replace guard after tensioning before starting the machine.

6.1.5.1 Checking belt tension

Tension is correct when a force of 10 kg is exerted on the belts at their mid-point between the upper and lower pulleys which deviates the belts by 15mm.

After the first 2 hours of work re-check the belt tension and taper locks, see 1 & 2 in Figure 6.6. Tighten if required, torque setting for Taper Locks is 45Nm.

Belt Tension;
15mm deviation under 10kg pressure at mid-point of belt run

Taper Locks;
Check tightness on new machines after initial 2 hours of work

The tension may vary depending on the size of the machine. To check and maintain the correct belt tension follow the instructions below;

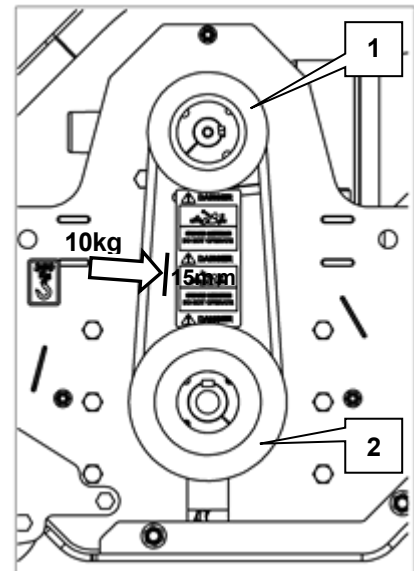

Figure 6.6

6.1.5.2 Belt adjustment – manual tension plate

Adjustment of the belt tension is performed by loosening the adjuster locking nut (A) and slackening half-shaft lock bolt (B) along with the four Gearbox mounting bolts (C), see Figure 6.7 below. Then using a spanner on the captive nut (D) rotate the cam plate (D) to increase or decrease belt tension until belt deviation matches the required measurement – see above. Belt tensioning should be performed when the belts are cold. Re-tighten bolts 'B' and 'C' and locknut 'A' when belt tension is correct.

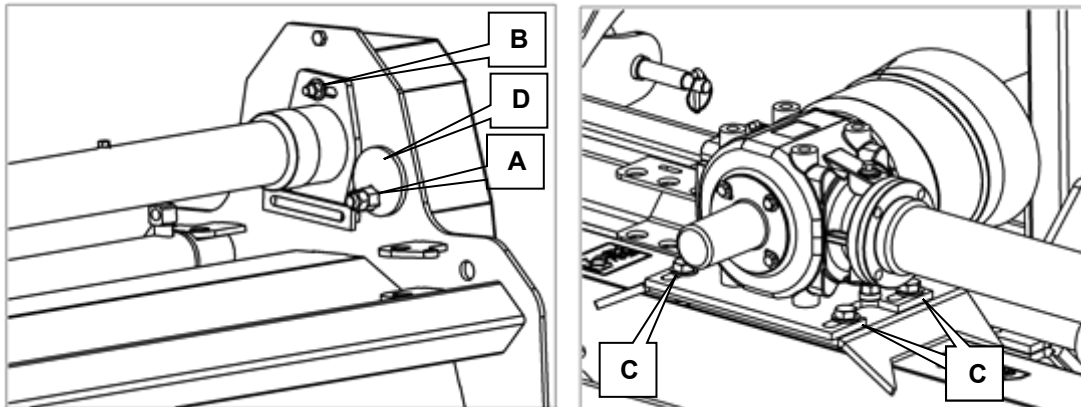

Figure 6.7

6.1.6 Adjusting the roller scraper

The scraper, mounted off the roller brackets and behind the roller, can be adjusted to control the distance from the lower leading edge of the scraper to the roller circumference. This is to enable distance setting and adjustment for any wear over time. To adjust the scraper, see Figure 6.8, and below;

- 6.1.6.1 At both ends of the roller, slacken the scraper retaining bolt (A) in the scraper captive nut.
- 6.1.6.2 Slide the scraper assembly towards the roller. (The retaining bolt moves in the slot in the roller bracket.)
- 6.1.6.3 When the desired gap is achieved re-tighten both scraper retaining bolts ensuring that the gap is consistent along the length of the scraper. (A)

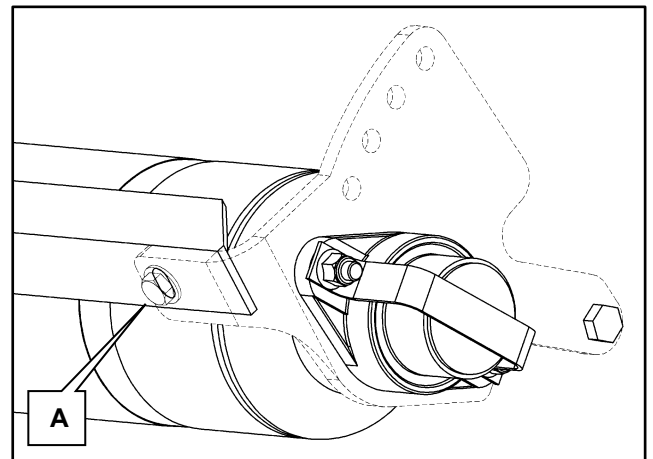

Figure 6.8

7 General operation

7.1 Operator training

These notes are produced for guidance and are intended to help the operator obtain the best results from the machine, with the minimum of trouble and downtime. The operator should read the following pages carefully and be familiar with the contents before commencing work. A familiar knowledge of the operator instruction manual forms an essential part of the training record for a competent user.

This machine is designed solely for vegetation control and must not be used for any other purpose. Use in any other way is considered as contrary to the intended use. Compliance with, and strict adherence to, the conditions of operation, service, and repair, as specified in this manual is also considered as the intended use.

This machine should be operated, serviced, and repaired only by persons who are familiar with its particular characteristics and who are acquainted with the relevant safety procedures. Accident prevention regulations, all other generally recognised regulations on safety and occupational medicine, and all road traffic regulations must be observed at all times.

This operator's manual should be regarded as part of the machine. Suppliers of both new and second-hand machines are advised to retain documentary evidence that this manual was provided with the machine. Record the serial number and product number inside the front cover of this manual. These numbers can be found on the machine serial number plate (See Figure 7.1) which is located on the front right-hand face of the cowl (See separate Parts book). Always quote these numbers in any correspondence with a dealer.



Figure 7.1

The parts manual supplied with the machine is specific to the construction of the machine. It will already contain the machine serial number on each page. Upon delivery always confirm that the parts book serial number matches the machine serial number.

7.2 Machine Inspection records:

Inspection record sheets are included in the front of this manual which can be used when inspecting the flail mower and tractor; these forms can be photocopied from the manual when further copies are required. When completed and filed in a machine log these records together with the operator training records and service records can accumulate to a useful machine ownership record.

Machines should be checked pre-delivery, post installation and prior to each work shift. Inspection should be carried out preferably by the operator or a suitably qualified responsible person.

The tractor engine must be switched off with the key removed. The cutting head must be positioned flat on the ground or suitably rested on blocks either side of the cutting head. All hydraulics must be rested, and residual pressure removed from any of the rams. Steam cleaning the machine will help with this inspection.

7.3 In the maintenance tool box: (Not supplied)

The user's own maintenance toolbox should contain a selection of replacement flails, shackles, washers and (new) fasteners matching those fitted to the flail mower prior to work. The toolbox should also contain the appropriate spanners (metric) to make the changes to flails and guarding if necessary.

7.4 Basic control

Before commencing work each day conduct a 'daily pre-work inspection' and record the findings on a copy of the 'Machine Inspection Record'. File this report safely as part of the 'Machine ownership record'.

Check that the tractor is equipped to deliver the correct rpm and rotation direction at the PTO shaft. There is a speed decal located adjacent to the gearbox input spline which will indicate the required rpm. The machine is designed to run at this speed. Check also that the machine is firmly and safely mounted.



WARNING! Under no circumstances must the PTO be run at speeds more than 5% higher than indicated. See Section 1; 'Machine general specification'.



WARNING! Increasing the PTO speed will directly increase the flail rotation speed. This can damage the rotor shaft and break flails prematurely. If the PTO speed is higher than recommended, then the flails will not be cutting at their optimum rate. This will also shorten the life of the machine.

7.4.1 Machine pre-start check

At every opportunity and before getting into the cab and starting the engine perform the following inspections;

- 7.4.1.1 Check that the rotor is free from obstructions especially pieces of wire.
- 7.4.1.2 Check that all flails are in good condition and securely attached to the rotor.
- 7.4.1.3 Check that all guards are in their correct place and in good condition (see Safety chapter).
- 7.4.1.4 Check the oil level in the gearbox before starting.

IMPORTANT: DO NOT OVERFILL. Most oils increase in volume as they warm up and aerate and can then spill out through the breather. (Refer to chapter; Gearbox oils and grease.)

7.4.2 Start up:



CAUTION! Do not start the rotor while it is under load. Always free the rotor from any obstructions first.

- 7.4.2.1 Adjust the cut height to suit the type of work to be done and the material to be cut. See section; 'Adjustments and settings'.
- 7.4.2.2 Ensure the PTO is disengaged.
- 7.4.2.3 Start the tractor unit.
- 7.4.2.4 With the tractor engine at tick-over speed engage the PTO.
- 7.4.2.5 Slowly increase engine speed to flail mower operational PTO speed. This can be found in Section 1; 'Machine general specification'.
- 7.4.2.6 Select forward working speed to suit the material to be cut and the degree of mulching required. The optimum forward speed range is 3 to 8 km per hour.



CAUTION! When executing tight turning manoeuvres, in field margins or at headlands lift the machine off the ground to avoid damaging the machine.



CAUTION! When reversing lift the machine off the ground to avoid damaging the machine.

7.4.3 Stopping:

- 7.4.3.1 Lower the cutting head on to the ground
- 7.4.3.2 Put the PTO out of gear
- 7.4.3.3 Apply the hand brake and if the ground is sloping, wedge the tractor securely
- 7.4.3.4 Stop the tractor engine, remove and pocket the starting key.



DANGER! **Be aware:** The flail mower is fitted with an overrun clutch. This means that even when drive is disengaged from the PTO the rotor shaft will continue to rotate under its own inertia for some time

7.4.4 Transportation to or from work site

Normally the machine will need to be driven to and from the work site before and after work. If necessary in order to keep the tractor and machine width to a minimum side shift the flail mower to the transport position which is illustrated in the 'Machine general specification' in section 1.

Before driving on the public highway check the following;

- 7.4.4.1 All parts of the flail mower are sufficiently clear of the tyres to prevent contact during bounce and sway on braking, turning and undulating ground.
- 7.4.4.2 Ensure sufficient ballast is added to the front of the tractor to maintain steering under bounce conditions.
- 7.4.4.3 Ensure that the axle loads do not exceed the plated axle limits for the tractor
- 7.4.4.4 Ensure the tyres are correctly inflated and rated for the axle loads.
- 7.4.4.5 Ensure all stop, tail and indicator lights are in working order are visible to road users at the rear and fit a trailer bar if appropriate.
- 7.4.4.6 Ensure that any debris; cut material, mud or stones that may have collected on the machine during work are removed before driving on the public highway. This will prevent any hazard to other road users being dropped onto the road.

IMPORTANT: When transporting on the highway, it is the responsibility of the operator to obey all relevant local highway laws.

IMPORTANT: Pay due care and attention to the driving conditions and drive accordingly. **DO NOT** travel too quickly over undulating ground. The flail head is a significant mass, thus braking, turning, sway and bounce can magnify forces and induce significant and damaging loads into the flail mower which is rigidly attached to the tractor. McConnell will not warrant damage bought about by abuse of the machines intended use or neglectful handling.

7.5 Cutting guidelines

7.5.1 The Tractor

Keep the tractor PTO speed at the indicated rpm in order to maintain the correct rotor speed for the job (see section 1.4 'Machine general specification'). Depending on the build of the fitted cutting unit this will be 2000 to 2200 rpm. Slower speeds may reduce the quality of cut obtained by the rotor.

7.5.2 The work area

- 7.5.2.1 Examine the piece of work to be cut. It is very important that the work site is inspected before cutting and all hidden obstructions removed, or their position clearly marked so that they may be avoided.
- 7.5.2.2 Check for tree stumps, drain pipes, large stones, wire etc.
- 7.5.2.3 Repeated stalling of the rotor in heavy growth is likely to cause damage to the rotor.



WARNING! Do not allow personnel near the machine while it is operating.

7.5.3 General cutting hints

- 7.5.3.1 The rotor shaft speed should ideally be between 2000 - 2200rpm.
- 7.5.3.2 Run the rotor using the indicated PTO speed.
- 7.5.3.3 Avoid rushing into the work. Remember that the unit must chop up the material as well as cut it to height.
- 7.5.3.4 Avoid taking in too much grass by regulating the forward speed of the tractor.
- 7.5.3.5 If the rotor shaft slows down or begins to choke up in grass, raise the cutting unit a little and allow grass to fall clear.
- 7.5.3.6 Before continuing with the cut let the rotor speed recover again.
- 7.5.3.7 Advantage may be gained in exceptional conditions by taking a narrow cut with part of the cutting unit clear of the work.

IMPORTANT: After the initial first 2 hours of work with a new machine, nuts and bolts should be checked for tightness and the drive belts inspected and re-tensioned if required

7.5.4 Stalling the rotor

If the rotor does become choked the tractor may stall or the belts may slip. If this occurs follow the instructions below:

- 7.5.4.1 Stop forwards motion and disengage drive to cutting unit immediately
- 7.5.4.2 Apply the hand brake and if the ground is sloping, wedge the tractor securely
- 7.5.4.3 Ensure that the rotor has stopped and lift the cutting unit.
- 7.5.4.4 Stop tractor engine, remove and pocket the starting key.
- 7.5.4.5 Remove any obstruction that may be present on the rotor.



WARNING! If working under the raised machine ensure that it is safely supported.

8 Removal, Storage and Disposal

Before removing the machine from the tractor, perform a thorough check of the machine.

8.1 Preparation for storage

Thoroughly clean all moving parts, particularly the cutting unit. Check that all flails are in place and that they are in good condition. Check any hoses for damage such as cracks, evidence of chafing and leaks. Smear all unpainted metal parts with grease and lubricate all grease nipples. Finally, in preparation for next seasons cutting make a note of any item that needs replacing so that parts can be ordered in good time.

8.2 Parking and removal

To detach the flail mower from the tractor for storage as follows;

- 8.2.1.1 To prevent the risk of rolling, locate a safe place with firm flat ground on which to store the flail mower. If necessary wedge the roller to prevent inadvertent movement, see Figure 8.1.
- 8.2.1.2 Bring the tractor to a stop in this location. If the machine has been transported to this location the PTO drive should already be disengaged. If the machine is to be demounted at the end of work, then disengage the PTO drive and side-shift the machine back into its transport position.
- 8.2.1.3 Lower the machine fully to the ground, apply the handbrake, turn off the engine and remove and pocket the ignition key.
- 8.2.1.4 When the rotor has stopped turning, decouple any lateral stabilizer chains or brackets to retaining the flail mower in a central lateral position
- 8.2.1.5 De couple and remove the PTO drive shaft (A).
- 8.2.1.6 Unwind the top link (B) to let the machine settle. The pins should not be holding any tension.
- 8.2.1.7 Remove the top link from the machine by unfastening the spring clip and withdrawing pin (C). Retain the pin and spring clip in the top link hole on the flail mower for future use.
- 8.2.1.8 Unfastening the spring clip and withdraw pins (D) from the lift arms (E). Retain the pins and spring clips in the bottom link of the flail mower for future use.
- 8.2.1.9 Start the tractor engine and drive carefully forward disengaging the machine from the tractor.
- 8.2.1.10 Store the PTO shaft in a safe place. Protect the mower PTO and spline from the effects of weather.

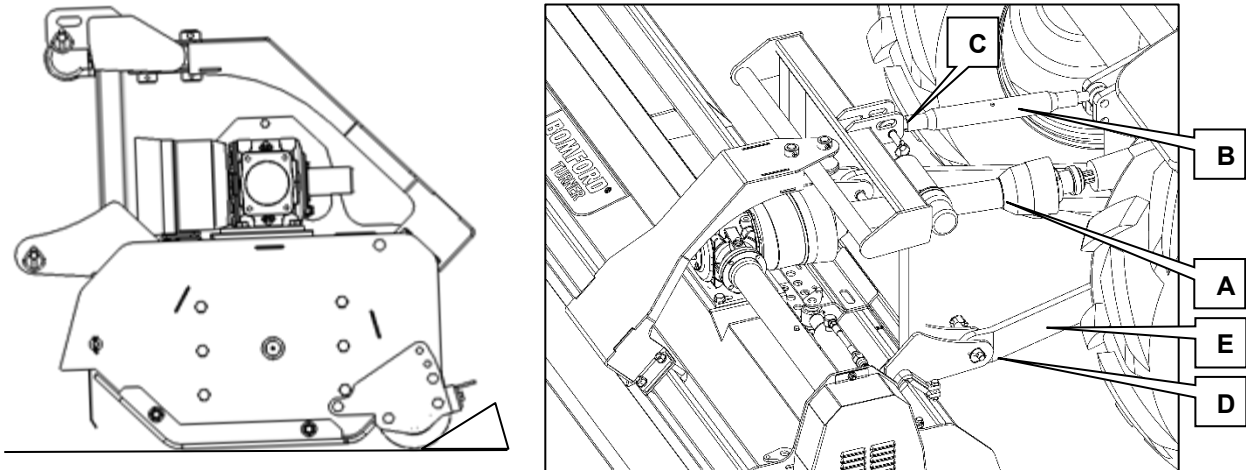

Figure 8.1

8.3 Disposal

When McConnell equipment reaches the end of its economic working life it should be disposed of responsibly, either through an approved recycling centre or by compliance with all applicable regulations in force in the destination territory.

In most instances McConnell machines can be broken into its constituent parts with the use of basic workshop equipment. Figure 8.2 contains a typical list of constituent materials, together with disposal guidelines.

When undertaking a machine breakdown, take care to ensure that heavy parts are always adequately supported to avoid injury.

To avoid environmental contamination, take containment precautions to retain control of liquids in order.

It is the owner's responsibility to ensure the machine is disposed of in accordance with all applicable regulations.

Material	Typically found in;	Disposal guideline
Steel	Structural components, fixed guards, fasteners and driveline	Can be dismantled and recycled. Take care when handling heavy and/or sharp objects
Aluminium	Pump and gearbox housings, serial number plates	Can be dismantled and recycled. Take care when handling heavy and/or sharp objects. Take appropriate actions for oil contaminated products
Copper	Wiring, electrical components	Can be recycled using appropriate recovery procedures.
Hydraulic oil	Tank, hydraulic components	Dispose of in accordance with all applicable regulations
Rubber	Hoses, flexible guards, seals, 'O' rings	Dispose of in accordance with all applicable regulations
Plastics	Clips, caps, cable ties, decals, filter housings, document holders, bushes, electrical components, plugs, connectors, wire insulation	Dispose of in accordance with all applicable regulations
Filter element	Filter housings	Dispose of in accordance with all applicable regulations
Cork / paper	Gaskets	Dispose of in accordance with all applicable regulations

Figure 8.2

9 Maintenance

For routine maintenance or repair spare parts may be obtained from the McConnel parts department.

To obtain correct part numbers; either refer to the parts manual specific to the serial number of your machine; which is supplied in a document holder attached to the machine; or, use the McConnel on-line parts books. These are available at on our website at the following address: www.mcconnel.com/support/product-support/interactive-parts-database/, you will need to enter the machine serial number. The correct part numbers must be quoted when ordering spares.

9.1 Regular preventative maintenance:

All maintenance, cleaning and repair operations must be performed with the machine firmly lowered to the ground and detached from the tractor or with the PTO disconnected, engine switched off and starting key removed. For any repairs or maintenance that requires access from underneath, the machine should be firmly and safely raised and propped using suitable purpose designed supports capable of bearing the machines full weight. Care should be adopted at all times when working with or under a raised machine.

Daily maintenance operations facilitate the removal of mud or other material from rotating parts (bearing, pins etc.) in order to avoid rust and possible seizures. This helps to prolong the service life of the machine.

Maintenance schedule			
Ref:	Interval	Function	Maintenance action
1	First 2 hrs	Belts	From new (or after fitting new belts) check belt tension and taper lock tightness – re tension and tighten if necessary
		Bolts and nuts	From new tighten
2	Every 8hrs	Bolts and nuts	Tighten
		Flails	Check wear and condition
		Guards	Check that all safety guards including the PTO guard are in good condition and replace if worn, cracked or damaged
		Belts	Check belt condition and tension
		Cowl and headstock	Check visually for damage caused by previous work
		Gearbox	Check lubrication levels
		Extension tube	Check lubrication levels
		Grease points	Grease at each grease point marked by a grease decal
		PTO shaft	Grease the PTO shaft tubes regularly
		Check chains	Ensure the guard check chains are securely attached and in good condition
3	First 50hrs	Gearbox	Drain and replace oil.
		Filters (if fitted)	Replace filter elements
4	Every week	PTO universal joints	Grease universal joints at both ends of the PTO shaft. Check bearing journals for roughness or slackness and replace if necessary.
5	Every month	Rams (if fitted)	Check ram caps for tightness and if necessary tighten immediately
		Pins	Check all pins for damage, wear and correct retention.
6	Every 500hrs	Filters (if fitted)	Replace filter elements
7	Every 1000hrs or annually (whichever is earlier)	Gearbox	Drain and replace oil.
		Drive-tube	Drain and replace oil.

9.2 Drive components

9.2.1 Power-Take-Off shaft (PTO)

The normal agricultural type of PTO shaft is used. Spares kits; comprising for example; the spider, needle bearings, circlips; are available from your dealer.

Some routine maintenance is needed to ensure a trouble-free life of the PTO shaft.

- 9.2.1.1 Grease both ends of the PTO shaft weekly.
- 9.2.1.2 Grease the PTO shaft tubes regularly.
- 9.2.1.3 Ensure the guard check chains are securely attached and in good condition.
- 9.2.1.4 Check that PTO guard is in good condition and replace it if cracked or damaged.
- 9.2.1.5 Check the universal joint bearing journals for roughness or slackness. Replace if necessary.

9.2.3 Gearbox

The gearbox (which contains a directional over run clutch) transmits the available power of the tractor PTO through a drive tube and into the rotor via a belt driven pulley system. Gearbox lubrication capacity is detailed in the 'Machine general specification' in chapter 1.0 and recommended oils are detailed in chapter 5.0. Gearbox mounting fasteners should always be torqued to at least 90-100Nm

IMPORTANT: Always check oil level before use and top up if necessary.

Drain and replace the oil after the first 50 hours' work and thereafter every 1000 hours or 12 months, whichever is the earlier. The positions of the filler plugs (F), level plugs (L), drain plugs (D) and breathers (B) are shown for both Drive-tube and gearbox in Figure 9.1 below for all Flail mower ranges.

(A) Medium-duty Magnum range

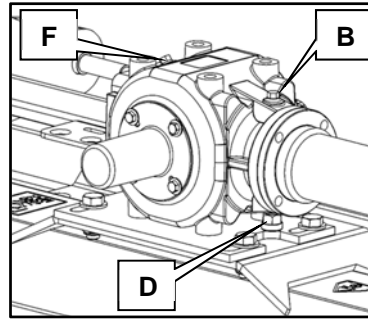
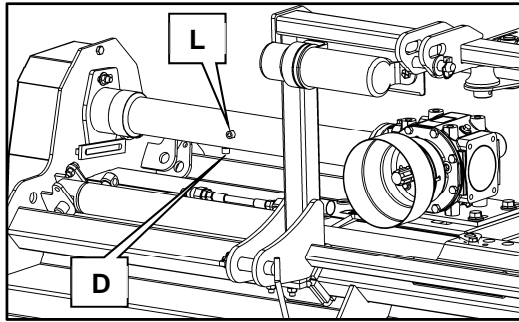

(B) Heavy-duty Magnum Combi range

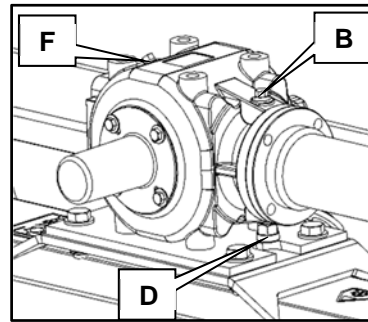
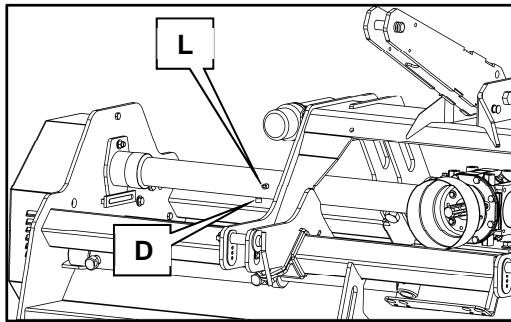

(C) Heavy-duty Magnum Open range

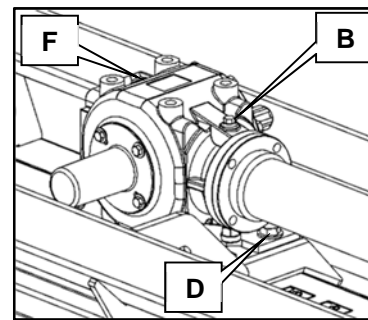
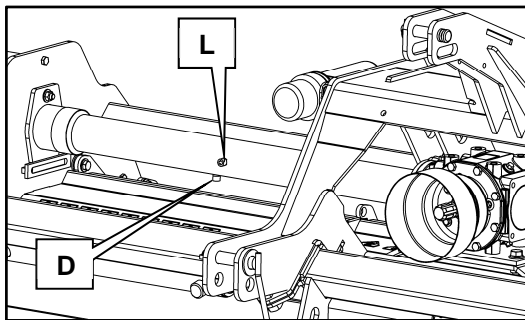

(D) Super-heavy-duty Magnum Mega range

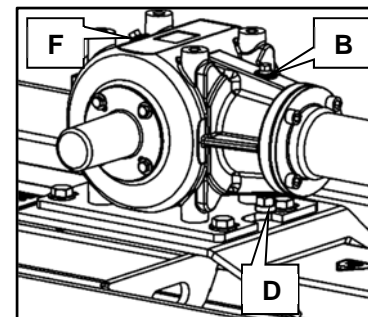
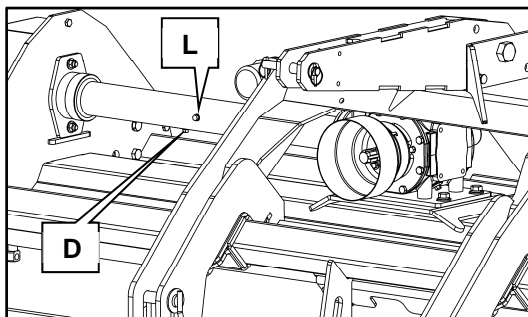

Figure 9.1

9.2.4 Rotor shaft

If vibration of the rotor occurs stop the machine immediately. This is often a sign that a flail is either missing or severely damaged. If this is the case **DO NOT** use the machine until the problem has been rectified. If vibration continues, or occurs for no apparent reason, the rotor must be checked by an authorised workshop and if necessary rebalanced before using the machine again. Contact your local dealer for further advice or assistance on this subject.



WARNING! Check flails daily. Check that flails are in good condition and securely attached to the rotor shaft. Replace any that are damaged. When replacing a flail always replace the retaining bolt and locknut at the same time.



CAUTION! Vibration of the rotor shaft will cause premature failure of the rotor shaft bearings. It is important not to operate the machine with the cutting unit vibrating.

As soon as any vibration is felt stop operating the machine and make the checks listed below:

9.2.4.1 Stop tractor engine and disengage PTO drive.

9.2.4.2 Lower the flail mower on to axle stands and ensure it is supported safely.

9.2.4.3 Check daily for missing or worn flails. Always replace missing or worn flails in pairs opposite each other to maintain shaft assembly balance.

IMPORTANT: A New flail must always be fitted with a new retaining bolt and locknut.

9.2.4.4 Check that the retaining bolts are in good condition. If any are found to be bent or in poor condition, then even if the flail is still good, replace the bolts and locknuts together.

9.2.4.5 Check that the securing locknuts are visibly tight. If any nuts are loose **do not** re-tighten the old locknut. Always replace with a new locknut and tighten. **Note:** Locknuts deform once, on fitting, to provide a prevailing torque (a torque-off resistance). The prevailing torque prevents the nut from coming loose due to vibration. If a locknut is subsequently re-tightened, then this protection is lost.

IMPORTANT: Only fit genuine McConnel spare parts.

9.2.4.6 If any flails were missing or loose and have been replaced or tightened, run the rotor and retest for vibration. If vibration is still present, check rotor shaft bearings as follows;

- Stop tractor engine and disengage PTO drive.
- Check rotor shaft bearings for roughness or signs of slackness.
- Replace the bearings if either of the above symptoms is found.
- If vibration persists it is an indication that the rotor shaft is probably bent and must therefore be replaced.

9.2.5 Flail replacement

The rotor and flails should be inspected for wear or damage on a regular basis – missing, damaged or worn flails should be replaced immediately. When replacing a flail, the diametrically opposite flail should also be replaced at the same time in order to maintain rotor balance. All replacement flails should be fitted with new retaining bolts and locknuts. The locknuts should be tightened to 300-320Nm. This is to ensure that the flail spacers are pinched tight and do not rotate. Check and confirm that the spacers are not loose after tightening the locknuts.



DANGER! Machine and tractor should be switched off and the starting key removed at all times when inspecting or maintaining the machine – Never work on a machine that is switched on and running.

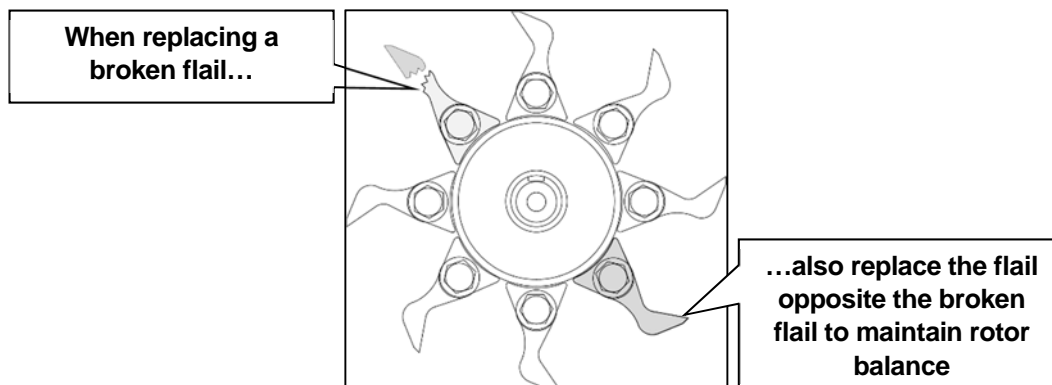

Figure 9.2

9.3 Hydraulic components (if fitted)

9.3.1 Rams

It is advisable to check all ram caps for tightness occasionally and if found to be loose tighten them immediately.

9.3.2 Filter(s)

The element(s) must be changed after the first 50 hours work and thereafter every 500 hours.

9.3.3 Hoses

It is false economy to try and make a damaged hose last a bit longer, because a failure can spill a lot of oil on the road endangering traffic, the environment and costing money. To reduce the risk of this happening and ensure a long life from the hoses, follow the guidelines below. On a weekly basis:

- 9.3.3.1** Check that all hoses and their connections are in good condition and that there are no leaks or damage. Replace any hose that is leaking or damaged.
- 9.3.3.2** Check to see that hoses are not and have not been chafing against sharp edges. If evidence of chafing is found, then inspect for damage and if found replace. Re-route any hose that has been chafing; see section on 'Hydraulic hose checks' in 'Installation' chapter.
- 9.3.3.3** Check to ensure that hoses are fitted without kinks or sharp bends.
- 9.3.3.4** If in doubt about the condition of any hose replace it. When replacing hoses, be sure to tighten to the correct torque setting, see Figure 9.3.



WARNING! Some hoses may contain residual pressure, take care when removing them.

BSP SWIVEL FEMALE TORQUE VALUES				
Thread Diameter (inch)	Metric (Nm)		Imperial (lbf.ft)	
	nominal	Min - max	nominal	Min - max
1/4	20	15 -25	14.75	11.06 - 18.44
3/8	34	27 - 41	25.07	19.91 - 30.24
1/2	60	42 - 76	44.25	30.97 - 56.05
5/8	69	44 - 94	50.88	32.45 - 69.32
3/4	115	95 - 135	84.81	70.06 - 99.56
1	140	115 - 165	103.24	84.81 - 121.68
1 1/4	210	140 - 280	154.87	103.24 - 206.49
1 1/2	290	215 - 365	213.86	158.55 - 269.17

METRIC SWIVEL FEMALE TORQUE VALUES				
Thread Diameter (mm x pitch)	Metric (Nm)		Imperial (lbf.ft)	
	nominal	Min - max	nominal	Min - max
M 16x1.5	26	25 -28	19.18	18.44 - 20.65
M 18x1.5	37	35 - 39	27.29	25.81 - 28.76
M 22x1.5	47	45 - 50	34.67	33.19 - 36.88
M 26x1.5	89	85 - 94	65.64	62.69 - 69.33
M 30x2.0	116	110 - 121	85.56	81.13 - 89.25
M 36x2.0	137	130 - 143	101.05	95.88 - 105.47
M 45x2.0	226	215 - 237	166.69	158.58 - 174.80
M 16x1.5	42	40 - 44	30.98	29.50 - 32.45
M 18x1.5	53	50 - 55	39.09	36.88 - 40.57
M 20x1.5	63	60 - 66	46.47	44.25 - 48.68
M 22x1.5	79	75 - 83	58.27	55.32 - 61.22
M 24x1.5	84	80 - 88	61.99	59.00 - 64.91
M 30x2.0	126	120 - 132	92.93	88.51 - 97.36
M 36x2.0	179	170 - 187	132.02	125.39 - 137.92
M 42x2.0	263	250 - 275	193.98	184.39 - 202.83

Figure 9.3

9.4 Structural components

9.4.1 Pins

Periodically check all pins for damage, wear and correct retention.

9.4.2 Greasing

There are a number of greasing points on the machine that need regular attention;

- 9.4.2.1 All pivot bushes on rams, offset arms and cowl linkages equipped with a grease nipple,
- 9.4.2.2 The breakaway link on the offset arm (if fitted)
- 9.4.2.3 Flail head rotor bearings
- 9.4.2.4 Flail head roller bearings
- 9.4.2.5 PTO knuckles
- 9.4.2.6 PTO engagement spline

These should all be greased after every 50hrs of work. When greasing the flail head roller and its bearings do not over grease or the carriers may be forced apart and distorted by the pressure.

IMPORTANT: Any good quality lithium-based grease may be used for lubrication of pivot pins and bearings.

Grease the rotor shaft bearings as follows:

- 9.4.2.7 Place the flail mower on the ground or support it safely.
- 9.4.2.8 Stop the tractor engine and disengage drive to the PTO shaft.
- 9.4.2.9 Rotor shaft bearing grease nipples are located behind a rubber grommet in the drive guard and within a protective boss in the non-drive side plate.
- 9.4.2.10 Roller bearing grease nipples are located in the bearing flange inside the roller side plates.
- 9.4.2.11 Apply grease to the nipples but do not grease violently as damage to the seals may result. Do not over grease or it could cause overheating.

10 Trouble shooting

Trouble shooting – Flail mower issues			
	Symptom	Possible cause	Remedy
10.1	Irregular cut	a) Worn, bent or broken flails	Replace flails immediately
		b) PTO Input speed too low	Check PTO input speed and increase to maximum indicated.
		c) Machine is not level to the ground	Level the machine. Check the roller function and condition.
		d) Clogged material due to excessive ground speed	Reduce tractor speed over ground and check correct PTO input speed.
10.2	Machine noise	a) Loose bolts	Check and tighten.
		b) Damage to cowl structure or cracks	Repair cowl in specialised workshops or replace.
		c) Vibration	See vibration below
10.3	Gearbox noise	a) Lack of oil	Fill to level
		b) Worn gears	Replace gears
		c) Worn bearings	Replace bearings
10.4	Vibration – Investigate quickly!	a) Lost flail(s)	Replace any missing flails in opposed pairs immediately
		b) Broken or worn flails	Replace flails in opposed pairs immediately
		c) Bent or Unbalanced rotor	Replace rotor or contact McConnel shaft reconditioning service.
		d) Worn rotor bearings	Replace in authorised workshops.
		e) PTO speed too high	Reduce PTO speed to the correct operating speed
10.5	Premature flail wear	Flails touching the ground	Adjust the height of cut using the roller
10.6	Excessive backlash	Worn pins	Check pin hole condition, replace pins in joints.
10.7	Roller breakage	Violent impact with ground	Lower the machine gently to the ground. Inspect damage. Replace or repair in authorised workshops.
10.8	Bearing function poor	a) Damage due to violent impact with ground	Replace in authorised workshops. Always lower machine gently.
		b) Wear due to lack of lubrication	Replace in authorised workshops. Follow grease maintenance schedule
10.9	Belts overheating	a) Belts slipping on pulleys	Check and adjust belt tension.
		b) Flail touching ground	Adjust the height of cut using the roller
		c) Working speed unsuitable for the material to be cut	Reduce tractor speed over ground and check correct PTO input speed.
10.10	Poor cutting performance	a) Flails worn out	Replace blades once the performance has dropped below an acceptable level
10.11	Poor power transmission	b) Drive belts slipping - low belt tension	Check and adjust belt tension
		c) Drive belts slipping - check for wear and or oil on drive belts	Replace when worn/oily and or shredded
10.12	Rotor continually stalls	a) Forward cutting speed too fast	Reduce forward cutting speed
		b) Cutting too close to the ground	Lower the roller to cut less. For shorter cut make more than one cut.
		c) Wrong PTO speed	If PTO speed is too low then the cutting inertia is reduced. Increase PTO rpm to correct cutting speed.
		d) Belts slipping- low belt tension	Check and adjust belt tension
		e) Belts slipping – oil on belts or belt wear	Replace when worn/oily and or shredded



McConnel Limited, Temeside Works, Ludlow, Shropshire SY8 1JL. England.
Telephone: 01584 873131. Facsimile: 01584 876463. www.mcconnel.com