

Publication 763
January 2014
Part No. 22675.63
Revision: 10.02.17



MAGNUM MULCHA 225

Heavy Duty Shredder Mower

Operator Manual



IMPORTANT

VERIFICATION OF WARRANTY REGISTRATION



Dealer Warranty Information & Registration Verification

It is imperative that the selling dealer registers this machine with McConnel Limited before delivery to the end user – failure to do so may affect the validity of the machine warranty.

To register machines; log onto <https://my.mcconnel.com> and select 'Machine Registration' which can be found in the 'Warranty' section of the site. **Confirm to the customer that the machine has been registered by completing the verification form below.**

| | |
|--|---------------------------------|
| Registration Verification | Serial No. <input type="text"/> |
| Dealer Name: | |
| Dealer Address: | |
| Customer Name: | |
| Date of Warranty Registration:/...../..... Dealer Signature: | |

Note to Customer / Owner

Please ensure the section above has been completed and signed by the dealer to verify your machine has been registered with McConnel Limited.

IMPORTANT: During the initial 'bedding in' period of a new machine it is the customer's responsibility to regularly inspect all nuts, bolts and hose connections for tightness and re-tighten if required. New hydraulic connections occasionally weep small amounts of oil as the seals and joints settle in – where this occurs it can be cured by re-tightening the connection – *refer to torque settings chart below*. The tasks stated above should be performed on an hourly basis during the first day of work and at least daily thereafter as part of the machine's general maintenance procedure.

CAUTION: DO NOT OVER TORQUE HYDRAULIC FITTINGS AND HOSES

Torque Settings for Hydraulic Fittings

| Hydraulic Hose Ends | | |
|---------------------|---------|--------|
| BSP | Setting | Metric |
| 1/4" | 18 Nm | 19 mm |
| 3/8" | 31 Nm | 22 mm |
| 1/2" | 49 Nm | 27 mm |
| 5/8" | 60 Nm | 30 mm |
| 3/4" | 80 Nm | 32 mm |
| 1" | 125 Nm | 41 mm |
| 1.1/4" | 190 Nm | 50 mm |
| 1.1/2" | 250 Nm | 55 mm |
| 2" | 420 Nm | 70 mm |

| Port Adaptors with Bonded Seals | | |
|---------------------------------|---------|--------|
| BSP | Setting | Metric |
| 1/4" | 34 Nm | 19 mm |
| 3/8" | 47 Nm | 22 mm |
| 1/2" | 102 Nm | 27 mm |
| 5/8" | 122 Nm | 30 mm |
| 3/4" | 149 Nm | 32 mm |
| 1" | 203 Nm | 41 mm |
| 1.1/4" | 305 Nm | 50 mm |
| 1.1/2" | 305 Nm | 55 mm |
| 2" | 400 Nm | 70 mm |

WARRANTY POLICY

WARRANTY REGISTRATION

All machines must be registered, by the selling dealer with McConnel Ltd, before delivery to the end user. On receipt of the goods it is the buyer's responsibility to check that the Verification of Warranty Registration in the Operator's Manual has been completed by the selling dealer.

1. LIMITED WARRANTIES

- 1.01. *All mounted machines supplied by McConnel Ltd are warranted to be free from defects in material and workmanship from the date of sale to the original purchaser for a period of 12 months, unless a different period is specified.
All Self Propelled Machines supplied by McConnel Ltd are warranted to be free from defects in material and workmanship from the date of sale to the original purchaser for a period of 12 months or 1500 hours. Engine warranty will be specific to the Manufacturer of that unit.*
- 1.02. *All spare parts supplied by McConnel Ltd and purchased by the end user are warranted to be free from defects in material and workmanship from the date of sale to the original purchaser for a period of 6 months. All parts warranty claims must be supported by a copy of the failed part invoice to the end user. We cannot consider claims for which sales invoices are not available.*
- 1.03. *The warranty offered by McConnel Ltd is limited to the making good by repair or replacement for the purchaser any part or parts found, upon examination at its factory, to be defective under normal use and service due to defects in material or workmanship. Returned parts must be complete and unexamined. Pack the component(s) carefully so that any transit damage is avoided. All ports on hydraulic items should be drained of oil and securely plugged to prevent seepage and foreign body ingress. Certain other components, electrical items for example, may require particular care when packing to avoid damage in transit.*
- 1.04. *This warranty does not extend to any product from which McConnel Ltd's serial number plate has been removed or altered.*
- 1.05. *The warranty policy is valid for machines registered in line with the terms and conditions detailed and on the basis that the machines do not extend a period of 24 months or greater since their original purchase date, that is the original invoice date from McConnel Limited.
Machines that are held in stock for more than 24 months cannot be registered for warranty.*
- 1.06. *This warranty does not apply to any part of the goods, which has been subjected to improper or abnormal use, negligence, alteration, modification, fitment of non-genuine parts, accident damage, or damage resulting from contact with overhead power lines, damage caused by foreign objects (e.g. stones, iron, material other than vegetation), failure due to lack of maintenance, use of incorrect oil or lubricants, contamination of the oil, or which has served its normal life. This warranty does not apply to any expendable items such as blades, belts, clutch linings, filter elements, flails, flap kits, skids, soil engaging parts, shields, guards, wear pads, pneumatic tyres or tracks.*
- 1.07. *Temporary repairs and consequential loss - i.e. oil, downtime and associated parts are specifically excluded from the warranty.*
- 1.08. *Warranty on hoses is limited to 12 months and does not include hoses which have suffered external damage. Only complete hoses may be returned under warranty, any which have been cut or repaired will be rejected.*
- 1.09. *Machines must be repaired immediately a problem arises. Continued use of the machine after a problem has occurred can result in further component failures, for which McConnel Ltd cannot be held liable, and may have safety implications.*
- 1.10. *If in exceptional circumstances a non McConnel Ltd part is used to effect a repair, warranty reimbursement will be at no more than McConnel Ltd's standard dealer cost for the genuine part.*

- 1.11. *Except as provided herein, no employee, agent, dealer or other person is authorised to give any warranties of any nature on behalf of McConnell Ltd.*
- 1.12. *For machine warranty periods in excess of 12 months the following additional exclusions shall apply:*
 - 1.12.1. *Hoses, exposed pipes and hydraulic tank breathers.*
 - 1.12.2. *Filters.*
 - 1.12.3. *Rubber mountings.*
 - 1.12.4. *External electric wiring.*
 - 1.12.5. *Bearings and seals*
 - 1.12.6. *External Cables, Linkages*
 - 1.12.7. *Loose/Corroded Connections, Light Units, LED's*
 - 1.12.8. *Comfort items such as Operator Seat, Ventilation, Audio Equipment*
- 1.13. *All service work, particularly filter changes, must be carried out in accordance with the manufacturer's service schedule. Failure to comply will invalidate the warranty. In the event of a claim, proof of the service work being carried out may be required.*
- 1.14. *Repeat or additional repairs resulting from incorrect diagnosis or poor quality previous repair work are excluded from warranty.*

NB Warranty cover will be invalid if any non-genuine parts have been fitted or used. Use of non-genuine parts may seriously affect the machine's performance and safety. McConnell Ltd cannot be held responsible for any failures or safety implications that arise due to the use of non-genuine parts.

2. REMEDIES AND PROCEDURES

- 2.01. *The warranty is not effective unless the Selling Dealer registers the machine, via the McConnell web site and confirms the registration to the purchaser by completing the confirmation form in the operator's manual.*
- 2.02. *Any fault must be reported to an authorised McConnell Ltd dealer as soon as it occurs. Continued use of a machine, after a fault has occurred, can result in further component failure for which McConnell Ltd cannot be held liable.*
- 2.03. *Repairs should be undertaken within two days of the failure. Claims submitted for repairs undertaken more than 2 weeks after a failure has occurred, or 2 days after the parts were supplied will be rejected, unless the delay has been authorised by McConnell Ltd. Please note that failure by the customer to release the machine for repair will not be accepted as a reason for delay in repair or submitting warranty claims.*
- 2.04. *All claims must be submitted, by an authorised McConnell Ltd Service Dealer, within 30 days of the date of repair.*
- 2.05. *Following examination of the claim and parts, McConnell Ltd will pay, at their discretion, for any valid claim the invoiced cost of any parts supplied by McConnell Ltd and appropriate labour and mileage allowances if applicable.*
- 2.06. *The submission of a claim is not a guarantee of payment.*
- 2.07. *Any decision reached by McConnell Ltd. is final.*

3. LIMITATION OF LIABILITY

- 3.01. *McConnell Ltd disclaims any express (except as set forth herein) and implied warranties with respect to the goods including, but not limited to, merchantability and fitness for a particular purpose.*
- 3.02. *McConnell Ltd makes no warranty as to the design, capability, capacity or suitability for use of the goods.*
- 3.03. *Except as provided herein, McConnell Ltd shall have no liability or responsibility to the purchaser or any other person or entity with respect to any liability, loss, or damage caused or alleged to be caused directly or indirectly by the goods including, but not limited to, any indirect, special, consequential, or incidental damages resulting from the use or operation of the goods or any breach of this warranty. Notwithstanding the above limitations and warranties, the manufacturer's liability hereunder for damages incurred by the purchaser or others shall not exceed the price of the goods.*
- 3.04. *No action arising out of any claimed breach of this warranty or transactions under this warranty may be brought more than one (1) year after the cause of the action has occurred.*

4. MISCELLANEOUS

- 4.01. McConnel Ltd may waive compliance with any of the terms of this limited warranty, but no waiver of any terms shall be deemed to be a waiver of any other term.*
- 4.02. If any provision of this limited warranty shall violate any applicable law and is held to be unenforceable, then the invalidity of such provision shall not invalidate any other provisions herein.*
- 4.03. Applicable law may provide rights and benefits to the purchaser in addition to those provided herein.*

McConnel Limited

FLAIL MOWER & TRACTOR PRE-OPERATION INSPECTION



A daily equipment inspection of machine and tractor should be conducted before the equipment is used.

Use the inspection sheets on the following pages to assist with these daily inspections. Damaged or missing guards should be repaired or replaced before operating the mower. Failure to repair or replace damaged guards can result in objects being thrown from the mower and possibly hitting the operator and/or bystanders.

Inspect the Mower for Safe Operating Condition

- Make sure the driveline guards and shielding are in place and in good repair.
- Inspect the chain guards, flexible and/or solid deflector thrown object shielding to assure that they are in place on the front and rear of the mower deck and in good repair. Repair or replace any damaged or missing thrown object shields.
- Ensure the mower cutting height is set high enough to reduce the possibility of the mower blades contacting the ground. Actual height will be dependent on the ground conditions. Increase the height when working in rough or undulating conditions.
- Inspect for broken, chipped, bent, missing, or severely worn blades. Replace damaged blades before operating the mower. Ensure the blade retaining bolts and fasteners are secure and tight.
- Lubricate the driveline universal joints and telescoping members daily.
- Inspect the wheel lug bolt/nuts to assure that they are tight.
- If mower is equipped with pneumatic tyres, make sure they have the required air pressure.
- Inspect for worn or damaged decals and safety instructions. Replace any unreadable, damaged or missing safety decals.
- Follow the operator's manual(s) inspection and maintenance instructions for lubricating parts, and keeping thrown object shielding, driveline guards, rotating parts shields, mower blades and decals in good repair.

Inspect the Tractor for Safe Operating Condition

- Inspect the controls, lights, SMV's (Slow Moving Vehicle sign), seat belts, and ROPS to ensure they are in place and in good working order.
- Ensure tyres, wheels, lug bolts/nuts are in good condition.
- Make sure the tractor brakes and steering are in proper operating condition.
- Follow the operator's manual(s) inspection and maintenance procedures for keeping the tractor in good and safe condition before operating.

Copies of the inspection sheets on the following pages should be retained in this manual for reference; two sets are included to allow removal of one set for photocopying purposes. Alternatively, these inspection sheets can be download from our website via the QR code or using the link below;
<https://my.mcconnel.com/service/pre-operation-inspection-documents/>





FLAIL MOWER PRE-OPERATION INSPECTION

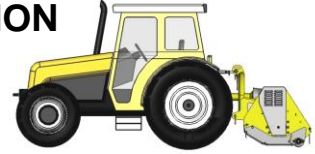

Mower ID Date: Shift:



WARNING: Before conducting the inspection, make sure the tractor engine is off, the key removed, all rotation has stopped and the tractor is in park with the parking brake engaged. Make sure the mower is resting on the ground or is securely blocked up and supported and all hydraulic pressure has been relieved.

| Item | Condition at start of shift | Specific Comments if not O.K. |
|--|-----------------------------|-------------------------------|
| The operator's manual is in the canister on the mower. | | |
| All warning decals are in place, clean and legible. | | |
| The hydraulic cylinder pins are tight and correctly secured. | | |
| The hydraulic cylinder hose connections are tight. | | |
| There are no oil leaks. | | |
| There are no damaged hoses. | | |
| Flails are not missing chipped, broken or excessively worn. | | |
| The flail bolts are tight. | | |
| The front and rear flaps are fitted and in good condition. | | |
| The skid shoes are in good condition and tight. | | |
| The rotor bearings are in good condition and greased. | | |
| The roller bearings are in good condition and greased. | | |
| There are no cracks or holes in flail casing. | | |
| The drive line/gearbox shaft guard is in good condition. | | |
| The drive line/gearbox shaft guard is correctly secured. | | |
| Driveline telescoping members & u-joints are lubricated. | | |
| Driveline yokes are securely attached to tractor and mower. | | |
| All linkage mounting pins are securely fastened. | | |

Operators Signature:

DO NOT OPERATE AN UNSAFE TRACTOR OR MACHINE



TRACTOR PRE-OPERATION INSPECTION

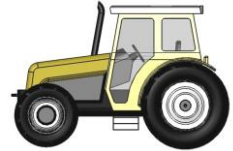

Power Arm ID Date: Shift:



WARNING: Before conducting the inspection, make sure the tractor engine is off, the key removed, all rotation has stopped and the tractor is in park with the parking brake engaged. Ensure any implement attached to the tractor is firmly on the ground.

| Item | Condition at start of shift | Specific Comments if not O.K. |
|---|-----------------------------|-------------------------------|
| The flashing lights function properly. | | |
| All lights are clean and working correctly. | | |
| All cab windows are clean and wipers working correctly. | | |
| The SMV sign, where required, is clean and visible. | | |
| The tyres are in good condition with correct pressure. | | |
| The wheel nuts are tight. | | |
| The tractor brakes are in good condition. | | |
| The steering linkage is in good condition. | | |
| There are no visible oil leaks. | | |
| The hydraulic controls function properly. | | |
| The ROPS or ROPS cab is in good condition. | | |
| The seatbelt is in place and in good condition. | | |
| The 3-point hitch is in good condition. | | |
| The drawbar/pick up hook is secure and in good condition. | | |
| The PTO master shield is in place. | | |
| The engine oil level is full. | | |
| The brake fluid level is full. | | |
| The power steering fluid level is full. | | |
| The fuel level is adequate. | | |
| The engine coolant fluid level is full. | | |
| The radiator and oil cooler are free of debris. | | |
| The air filter is in good condition. | | |

Operators Signature:

DO NOT OPERATE AN UNSAFE TRACTOR OR MACHINE



FLAIL MOWER PRE-OPERATION INSPECTION

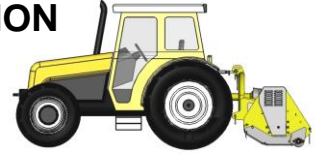

Mower ID Date: Shift:



WARNING: Before conducting the inspection, make sure the tractor engine is off, the key removed, all rotation has stopped and the tractor is in park with the parking brake engaged. Make sure the mower is resting on the ground or is securely blocked up and supported and all hydraulic pressure has been relieved.

| Item | Condition at start of shift | Specific Comments if not O.K. |
|--|-----------------------------|-------------------------------|
| The operator's manual is in the canister on the mower. | | |
| All warning decals are in place, clean and legible. | | |
| The hydraulic cylinder pins are tight and correctly secured. | | |
| The hydraulic cylinder hose connections are tight. | | |
| There are no oil leaks. | | |
| There are no damaged hoses. | | |
| Flails are not missing chipped, broken or excessively worn. | | |
| The flail bolts are tight. | | |
| The front and rear flaps are fitted and in good condition. | | |
| The skid shoes are in good condition and tight. | | |
| The rotor bearings are in good condition and greased. | | |
| The roller bearings are in good condition and greased. | | |
| There are no cracks or holes in flail casing. | | |
| The drive line/gearbox shaft guard is in good condition. | | |
| The drive line/gearbox shaft guard is correctly secured. | | |
| Driveline telescoping members & u-joints are lubricated. | | |
| Driveline yokes are securely attached to tractor and mower. | | |
| All linkage mounting pins are securely fastened. | | |

Operators Signature:

DO NOT OPERATE AN UNSAFE TRACTOR OR MACHINE



TRACTOR PRE-OPERATION INSPECTION



Power Arm ID Date: Shift:



WARNING: Before conducting the inspection, make sure the tractor engine is off, the key removed, all rotation has stopped and the tractor is in park with the parking brake engaged. Ensure any implement attached to the tractor is firmly on the ground.

| Item | Condition at start of shift | Specific Comments if not O.K. |
|---|-----------------------------|-------------------------------|
| The flashing lights function properly. | | |
| All lights are clean and working correctly. | | |
| All cab windows are clean and wipers working correctly. | | |
| The SMV sign, where required, is clean and visible. | | |
| The tyres are in good condition with correct pressure. | | |
| The wheel nuts are tight. | | |
| The tractor brakes are in good condition. | | |
| The steering linkage is in good condition. | | |
| There are no visible oil leaks. | | |
| The hydraulic controls function properly. | | |
| The ROPS or ROPS cab is in good condition. | | |
| The seatbelt is in place and in good condition. | | |
| The 3-point hitch is in good condition. | | |
| The drawbar/pick up hook is secure and in good condition. | | |
| The PTO master shield is in place. | | |
| The engine oil level is full. | | |
| The brake fluid level is full. | | |
| The power steering fluid level is full. | | |
| The fuel level is adequate. | | |
| The engine coolant fluid level is full. | | |
| The radiator and oil cooler are free of debris. | | |
| The air filter is in good condition. | | |

Operators Signature:

DO NOT OPERATE AN UNSAFE TRACTOR OR MACHINE

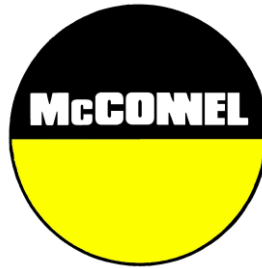

For Safety and Performance...

ALWAYS READ THE BOOK FIRST

McCONEL LIMITED

**Temeside Works
Ludlow
Shropshire
England**

**Telephone: +44 (0)1584 873131
www.mcconel.com**

- NOISE STATEMENT -

The equivalent daily personal noise exposure from this machine measured at the operators' ear is within the range 78 – 85 dB, these figures apply to a normal distribution of use where the noise fluctuates between zero and maximum. The figures assume that the machine is fitted to a tractor with a 'quiet' cab with the windows closed in a generally open environment. We recommend that the windows are kept closed. With the cab rear window open the equivalent daily personal noise exposure will increase to a figure within the range 82 – 88 dB. At an equivalent daily noise exposure level of 85 – 90 dB ear protection is recommended and must always be used if any window is left open.



Operating, servicing and maintaining this equipment can expose you to chemicals including gasoline, diesel fuel, lubricants, petroleum products, engine exhaust, carbon monoxide, and phthalates, which are known to the State of California to cause cancer and birth defects or other reproductive harm. To minimize exposure, avoid breathing exhaust, do not idle the engine except as necessary, service your vehicle in a well-ventilated area and wear gloves or wash your hands frequently when servicing your vehicle. Battery posts, terminals and related accessories contain lead and lead compounds, chemicals known to the state of California to cause cancer, birth defects or other reproductive harm. For more information go to www.P65Warnings.ca.gov. This website, operated by California's Office of Environmental Health Hazard Assessment, provides information about these chemicals and how individuals may be exposed to them.

LIST OF CONTENTS

| | |
|--------------------------------------|----|
| General Information | 1 |
| Machine Description & Purpose of Use | 2 |
| Machine Identification | 2 |
| Technical Specifications | 3 |
| Safety Information | 4 |
| Safety Decals | 5 |
| Vehicle / Tractor Preparation | 6 |
| Machine Attachment | 7 |
| PTO Shaft | 7 |
| Pre-Operational Checks | 8 |
| Transport | 8 |
| Operation | 8 |
| Detachment and Storage | 9 |
| Drive Belts | 10 |
| Belt Adjustment | 10 |
| Maintenance | 12 |
| Troubleshooting | 14 |
| Torque Settings | 15 |

GENERAL INFORMATION

Always read this manual before fitting or operating the machine – whenever any doubt exists contact your dealer or the McConnel Service Department for advice and assistance.

Use only McConnel Genuine Service Parts on McConnel Equipment and Machines

DEFINITIONS – The following definitions apply throughout this manual:

WARNING

An operating procedure, technique etc., which –
can result in personal injury or loss of life if not observed carefully.

CAUTION

An operating procedure, technique etc., which –
can result in damage to either machine or equipment if not observed carefully.

NOTE

An operating procedure, technique etc., which –
is considered essential to emphasis.

LEFT AND RIGHT HAND

This term is applicable to the machine when attached to the tractor and is viewed
from the rear – this also applies to tractor references.

MACHINE & DEALER INFORMATION

Record the Serial Number of your machine on this page and always quote this number when ordering parts. Whenever information concerning the machine is requested remember also to state the make and model of tractor to which the machine is fitted.

| | |
|------------------------|--------------------|
| Machine Serial Number: | Installation Date: |
| Machine Model details: | |
| Dealer Name: | |
| Dealer Address: | |
| Dealer Telephone No: | |
| Dealer Email Address: | |

MACHINE DESCRIPTION & PURPOSE OF USE

The Magnum 'Mulcha 225' is a tractor mounted universal heavy duty mower/shredder designed primarily for the mulching of standing or cut vegetation and stumps up to a maximum thickness of 300mm (12").

It's robust construction and working width of 2.25 metres makes it the ideal machine for high performance heavy duty maintenance work on scrubland areas, or in orchards, woods and forests.

Machines are available with a choice of either hard faced swinging hammer flails mounted on a heavy duty shaft, or alternatively for extra heavy duty work fixed hammers with replaceable tungsten carbide teeth can be specified that act to incorporate the mulched materials into the soil.

This machine should only be used to perform the tasks for which it was designed – use of the machine for any other function is both dangerous to persons and damaging to components.



MACHINE IDENTIFICATION

Each machine is fitted with an identification plate which includes the following information:

1. **Model/Code** (Part Number)
2. **Serial Number**

When ordering spares or replacement parts from your local dealer it is important to quote machine part number and serial number as stated on the identification plate so the machine and model can be quickly and correctly identified.



Machine Identification Plate

TECHNICAL SPECIFICATIONS

| SPECIFICATION | Mulcha 225 |
|--|-------------------------|
| Working Width | 2250mm |
| Tractor Power Requirement | 90 HP |
| PTO RPM – Machines to 2015 (Standard Build) | 540RPM |
| PTO RPM – Machines 2015 onwards (Standard Build) | 1000RPM |
| PTO RPM – Machines 2015 onwards (Optional Build only) | 540RPM |
| Hammers (No.) | 36 |
| Machine Weight (Swing Hammer Build) | 1280kg |
| Machine Weight (Fixed Hammer Build) | 1305kg |
| Linkage Type | 3-Point (Cat. II & III) |
| Machine Width | 2500mm |

Rotor Shaft Speeds

Machines 2015 onwards – Standard 1000RPM Builds

When running at 1000RPM tractor speed - rotor shaft speed is 2275RPM

Machines 2015 onwards – Optional 540RPM Builds

When running at 540RPM tractor speed - rotor shaft speed is 1230RPM

Machines up to 2015 – Standard 540RPM Builds

When running at 540RPM tractor speed - rotor shaft speed is 1750RPM

Machine Features

- Hydraulic Flap
- Heavy Duty Replaceable Skids
- 3-Point Linkage Mounted
- Cat II or Cat III Linkage
- Front 'Double Row' Chain Guard
- Front Mountable
- Rear Pushbar

Noise Level

The sound level of this machine, as measured at the operator's ear, is within the range of 70 to 90 dB when the rear window of the tractor is open. We recommend that ear protectors are worn and the tractor windows kept closed at all times when operating this machine.

SAFETY INFORMATION

General safety rules:

- ▲ Always read and follow the instructions for the use and maintenance of the machine before carrying out any work operations or servicing tasks.
- ▲ Improper use of the machine is both highly dangerous to persons and damaging to the machine components – only use the machine for its designated task.
- ▲ Both operators and the maintenance fitters should be familiar with the machine and fully aware of dangers surrounding improper use or incorrect repairs.
- ▲ Before starting, checks to both tractor and machine must be carried out as regards: functionality, road safety, accident prevention rules.
- ▲ Even when using the machine correctly, stones or other objects may be thrown a long distance. Therefore nobody must stand within the danger area. Special attention must be paid when working near roads or buildings.
- ▲ Use tractor's fitted with safety cabs.
- ▲ The condition of flails and of machine guards must be checked before beginning the daily work - they must be replaced if damaged or missing before you use the machine.
- ▲ During checks or repairs, make sure nobody could start the machine by mistake.
- ▲ Never carry passengers on the tractor.
- ▲ Never carry passengers on the machine.
- ▲ Never connect the power takeoff with the engine running.
- ▲ Never approach the machine until the rotor has completely stopped.
- ▲ Do not enter the working zone of the PTO shaft. It is dangerous to approach the rotating parts of a machine.
- ▲ Keep the PTO shaft guard in good condition.
- ▲ Before starting, check the surrounding area for the likely presence of children and/or animals.
- ▲ Do not stand near the machine when it is operating.
- ▲ Take care when working on rough or uneven terrain as lower protection is reduced.
- ▲ The PTO shaft must be assembled and disassembled only with the engine stopped and the starting key removed.
- ▲ Before connecting the power takeoff, check that the speed and the rotational direction correspond to those of the machine.
- ▲ Immediately replace missing or damaged safety decals.
- ▲ Before leaving the tractor with the machine attached, proceed as follows:
 1. Disconnect the power takeoff,
 2. Put the machine steadily on the ground using the tractor's hydraulic lift.
 3. Apply the hand brake and, if the ground is steeply sloping, wedge the tractor.
 4. Remove the starting key.

Transportation Safety

- ▲ In transport, reduce speed, especially on bumpy roads, the weight of the machine may render driving difficult and damage the machine itself.
- ▲ Ensure the levers that operate the hydraulic lift are locked, to avoid the lowering of the machine during transport.
- ▲ When driving on public roads, respect all road rules in force.
- ▲ Never transport the machine with the rotor running, even for short distances.

Operating Safety

- ▲ Pay special attention when working with the machine not to touch fixed objects such as drains, walls, shafts, kerbs, guard rails, tracks etc. This could cause the breakage of the components, which could be thrown out of the machine at very high speed.
- ▲ If wires, ropes or chains should become entangled in the rotor stop immediately to prevent damage or dangerous situations; stop the rotor and the tractor, take out the starting key. Put working gloves on; clear the rotor with the aid of pliers or shears. Do not try to disentangle by inverting the rotational direction of the rotor.
- ▲ Do not use the machine when excessive vibration is experienced, as this may cause breakage and serious damage - find the cause of the vibration and eliminate it before using the machine again.

Although the information given here covers a wide range of safety subjects, it is impossible to predict every eventuality that can occur under differing circumstances whilst operating this machine. No advice given here can replace 'good common sense' and 'total awareness' at all times, but will go a long way towards the safe use of your McConnell machine.

SAFETY DECALS



1. Danger; do not work under a raised or unsupported machine.
2. Danger zone, keep clear; risk from crushing.
3. Keep clear of working machine; risk from projection of objects.
4. Keep a safe distance from the machine at all times; risk from raised machine.
5. Always switch machine off, remove starting key and read instruction manual before performing service or maintenance work on the machine.
6. Risk of hand or feet injuries; always ensure all machine safety guards are in place when the machine is running.
7. Keep a safe distance from the machine at all times; risk of entanglement.
8. Ensure nuts and bolts are kept tight.
9. Read the manual first before attempting to operate or service the machine.

VEHICLE / TRACTOR PREPARATION

We recommend vehicles are fitted with cabs using 'safety glass' windows and protective guarding when used with our machines.

Fit Operator Guard (Part No. 7313324) using the hooks provided. Shape the mesh to cover all vulnerable areas.

Remember the driver must be looking through mesh and/or polycarbonate

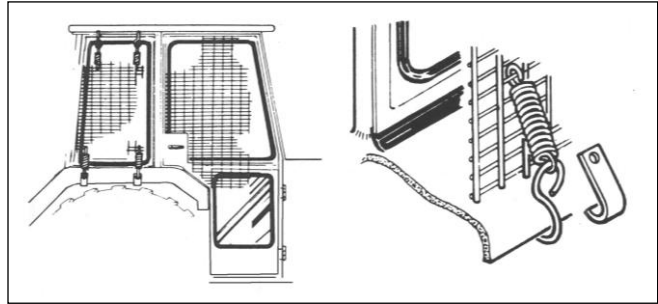

glazing when viewing the machine in all positions - unless the vehicle/ cab manufacturer can demonstrate that the penetration resistance is equivalent to, or higher than, that provided by mesh/polycarbonate glazing. If the tractor has a roll bar only, a frame must be made to carry both mesh and polycarbonate glazing. The operator should also use personal protective equipment to reduce the risk of serious injury such as; eye protection (mesh visor to EN1731 or safety glasses to EN166), hearing protection to EN352, safety helmet to EN297, gloves, filter mask and high visibility clothing.

Vehicle Ballast

It is imperative when attaching 'third-party' equipment to a vehicle that the maximum possible stability of the machine and vehicle combination is achieved – this can be accomplished by the utilisation of 'ballast' in order to counter-balance the additional equipment added.

Front weights may be required for rear mounted machines to place 15% of total outfit weight on the front axle for stable transport on the road and to reduce 'crabbing' due to the drag of the cutting unit when working on the ground.

Where a machine works to the side of the tractor rear weights may be required to maintain a reasonable amount of rear axle load on the opposing wheel.

All factors must be addressed in order to match the type and nature of the equipment added to the circumstances under which it will be used - factors that effect stability are:

- *Centre of gravity of the tractor/machine combination.*
- *Geometric conditions, e.g. position of the cutting head and ballast.*
- *Weight, track width and wheelbase of the tractor.*
- *Acceleration, braking, turning and the relative position of the cutting unit during these operations.*
- *Ground conditions, e.g. slope, grip, load capability of the soil/surface.*
- *Rigidity of implement mounting.*

Suggestions to increase stability:

- *Increasing rear wheel track - a vehicle with a wider wheel track is more stable.*
- *Ballasting the wheel; it is preferable to use external weights but liquid can be added to around 75% of the tyre volume – water with anti-freeze or the heavier Calcium Chloride alternative can be used.*
- *Addition of weights – care should be taken in selecting the location of the weights to ensure they are added to a position that offers the greatest advantage.*
- *Front axle locking, check with tractor manufacturer.*

The advice above is offered as a guide for stability only and is not a guide to vehicle strength. It is therefore recommended that you consult your vehicle manufacturer or local dealer to obtain specific advice on this subject, additionally advice should be sought from a tyre specialist with regard to tyre pressures and ratings suitable for the type and nature of the machine you intend to fit.

ATTACHING THE MACHINE TO THE TRACTOR

Attachment of machine to tractor should always be performed on a firm level site.

Attachment to Tractor

Position the tractor's lower linkage at the same height as the machine's lower attachment points.

Carefully drive the tractor squarely up to the machine and attach the tractor's lower linkage points to the machine using pins that match the tractor's linkage (Cat. II or III).

Fit top link to upper attachment point.

Raise the machine on the tractor's hydraulics and adjust the top link so that the machine is parallel to the ground.

Fit and adjust check chains and/or stabiliser bars if applicable to lock the machine into a central position on the tractor.

Connect machine's hydraulic hoses to the tractor's hydraulic service.

Fit PTO Shaft and attach torque chains to a suitable location – refer below for details of PTO measurement and shaft length adjustment.

PTO Shaft Measurement

Measure the PTO shaft and cut to the dimension shown – the finished length of the PTO shaft should be 75mm (3") less than the measured distance 'A' - between tractor shaft and gearbox stub shaft - to enable fitting.

NOTE: For subsequent use on different tractor measure again; there must be a minimum shaft overlap of 150mm (6").

Fit PTO in position and attach the torque chains to a convenient location to prevent the shaft guards from rotating.

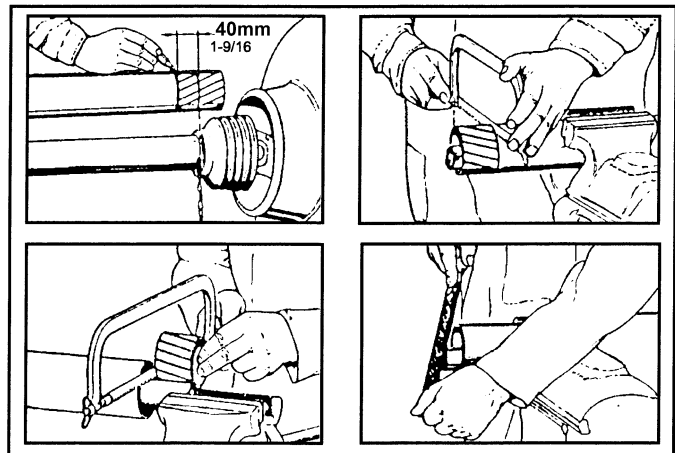

PTO Shaft Length Adjustment

1. Shorten outer plastic tube to 40mm less than the shortest envisaged shaft length.
2. Remove the marked tube.
3. Remove same length from inner plastic tube and metal shaft profiles (inner and outer).
4. De-burr all edges and remove 'swarf' to ensure smooth operation.

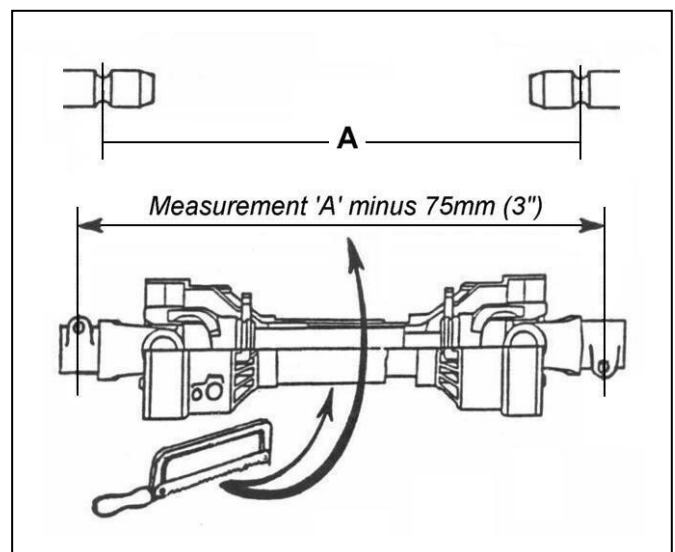

Start the machine to check it runs correctly.



WARNING!

Ensure any bystanders, onlookers or animals are at a safe distance before attempting to start and run the machine.

OPERATION



Ensure that the operator is suitably qualified to use a machine of this nature and that they have fully read and understood this manual - they should be aware of all safety aspects relating to the safe use of the machine.

It is advisable that all 'first time' operators practice using the machine in a clear safe area prior to work in order to familiarise themselves with its operation.

After the initial first 2 hours of work with a new machine, nuts and bolts should be checked for tightness and tightened if required.

Pre-Operational Checks

Before commencing work with the machine the following checks should be performed;

- Make a visual inspection of the machine to ensure it is in good operational condition.
- Check all safety guarding is in position and in full working order.
- Check rotor for missing or damaged flails and replace if required.
- Check all greasing points are well lubricated.
- Check gearbox oil level.
- Check belt tension and adjust if required.
- Check PTO speed and direction match that of the machine.

Transport

The following must be observed at all times when transporting the machine;

- Machine must always be switched off.
- Machine must be raised to a suitable transportation height.
- Speed must be kept to a minimum especially on bumpy roads or terrain.
- Local laws and road regulations must be respected at all times.
- Be aware of the machines width at all times and drive with due care and attention.

Pre-Work

Prior to starting work the area should be checked for dangerous objects such as large stones, wire, glass etc. and any hazardous objects removed from the area prior to operation with the machine. The location of unmovable or natural hazards should be noted, or if necessary 'marked', to indicate to the operator that the area should either be avoided or additional caution adopted whilst working around the hazard.

Starting Work

With the machine switched off, lower it into a position approximately 10cm above the ground, start the machine and allow it to build up to the correct working speed before gently lowering the it onto the ground - the machine is now in its working position and forward travel into the work can begin.

Working Speed

The working speed will depend on the working conditions and nature of the material being cut. Optimal speed will be in the region of 2 to 3 km/h at an engine speed of 1800 to 2000rpm.

Reversing & Turning

When reversing or turning the unit the machine should be stopped and lifted clear of the ground to protect components.

Hydraulic Flap

The machine features a hydraulically operated flap which can be opened as required for working with denser materials. Extra care should be adopted when the flap is in the open position as projectiles from the working machine will be ejected to a greater distance.

Stopping the Machine

When stopping the machine, forward travel should be halted before disengaging the PTO; leave the machine on the ground until the rotor has stopped turning completely before attempting to raise the machine.

Machine Parking

When parking the machine it should be placed at rest on the ground on a level firm site. Always remove and pocket the tractor's starting key when leaving the unit unattended.

DETACHMENT & STORAGE

Detaching the machine from the tractor

Removal of the machine should be performed on a firm level site.

The procedure for detachment is as follows:

- Gently lower the machine fully to the ground.
- Switch off the tractor and remove its starting key.
- Detach hydraulic hoses from the tractor service and stow them neatly on the machine.
- Remove the PTO driveshaft.
- Remove the top link and both pins from the lower attachment points.
- Carefully and slowly drive the tractor clear of the machine.
- Clean and lubricate the machine in preparation for next use.
- Ensure the machine is left in a safe stable condition.

Storage

For extended periods of storage it is advisable that the machine be kept in a clean dry environment protected from the elements to avoid risk of corrosion. The machine should be thoroughly cleaned and lubricated prior to storage. At this point it is good practice to check the machine for worn or damaged components - any parts that require replacing should be ordered and fitted at the earliest opportunity so the machine is fully prepared for the next season's work.

DRIVE BELTS

Power from the tractor via the machines gearbox and half-shaft is transferred to the rotor via a 4-belt pulley system.

Belt Tension

It is important that the belts are kept correctly tensioned for both optimal operation of the machine and long lasting belt life. Belts are correctly tensioned when they deflect by 11mm under a load of 7.5kg (16.5lbs.). Refer below for details of the belt adjustment procedure.

In addition to the belt tension the tightness of the taper lock bolts should be checked on a regular basis; the correct torque setting is 45Nm (33ft.lbs).

No other adjustment or maintenance will be required on the belt tensioning system other than routine inspection and general cleaning of components when checking the belts for wear.

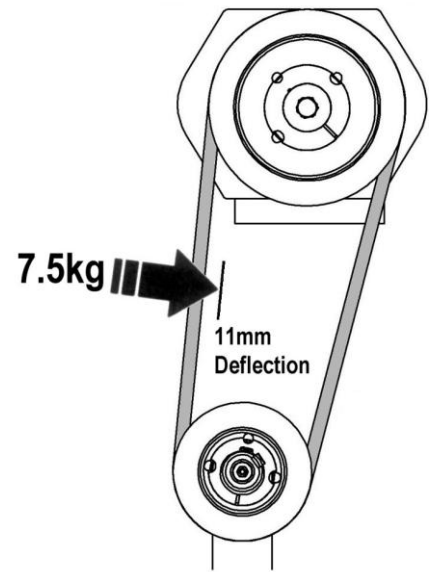

Belt Replacement

When fitting new belts they should be replaced as a complete set to ensure uniform drive tension; always use genuine McConnell replacement parts.

When replacing belt sets they must be correctly tensioned as shown below - inspect the belts after the first 2 hours of work and re-tension if necessary.

Belt Adjustment



WARNING: Checking of belts and drive components should only be carried out with tractors engine switched off, starting key removed and the PTO shaft disconnected. Never attempt to run the machine with the belt guard removed.

The procedure for adjusting belt tension is stated below. The adjustment components referred to are shown on the following page to aid identification.

- Remove belt cover.
- Slacken off the 4 gearbox mounting bolts.
- Slacken off the 2 upper pulley mounting bolts.
- Slacken adjuster bolt locknuts on each adjuster.
- Regulate adjusters to achieve the correct belt tension.
Turning the adjuster clockwise will decrease belt tension, anti-clockwise will increase tension. Ensure half-shaft is kept parallel to the machines frame during and after the tensioning procedure.
- Re-tighten adjuster bolt locknuts on both adjusters.
- Re-tighten fully the 2 upper pulley mounting bolts.
- Re-tighten fully the 4 gearbox mounting bolts.
- Re-check belt tension to ensure correct setting. *Repeat the procedure above if further adjustment is required.*
- Replace drive belt cover before starting the machine.

Belt Adjustment Components

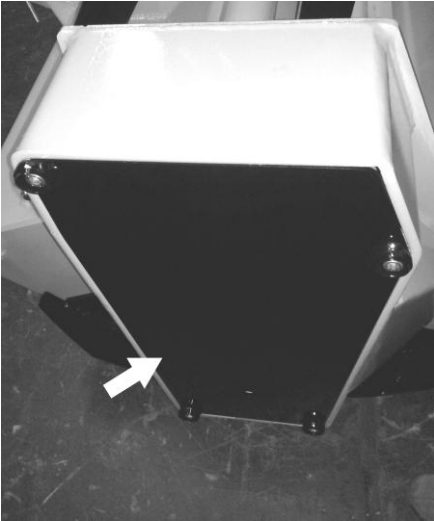

Belt Cover



Gearbox Mounting Bolts



Upper Pulley Mounting Bolts

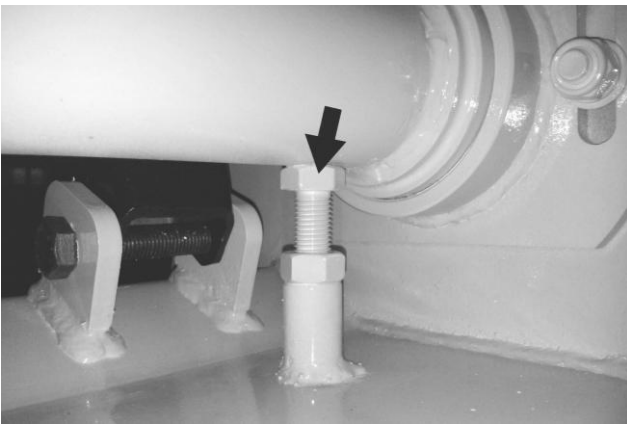

Belt Tension Adjuster (Pulley End)

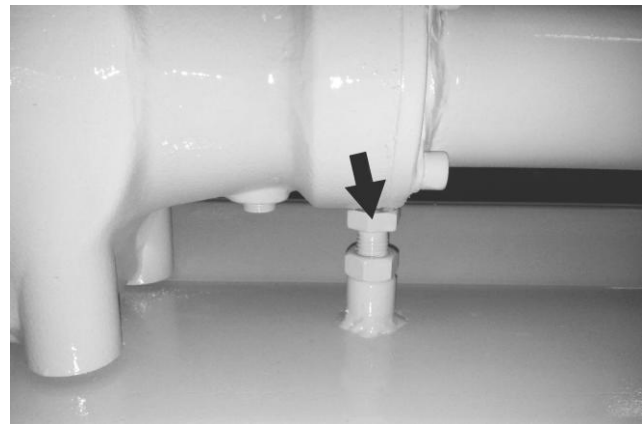

Belt Tension Adjuster (Gearbox End)

IMPORTANT: When adjusting belt tension always ensure that the gearbox is moved by the same distance, and in the same direction, as the upper belt pulley; this will ensure that the half-shaft remains parallel to the rotor allowing the belts to run true – *failure to observe this may result in rapid belt wear, excess vibration and possible damage to components.*

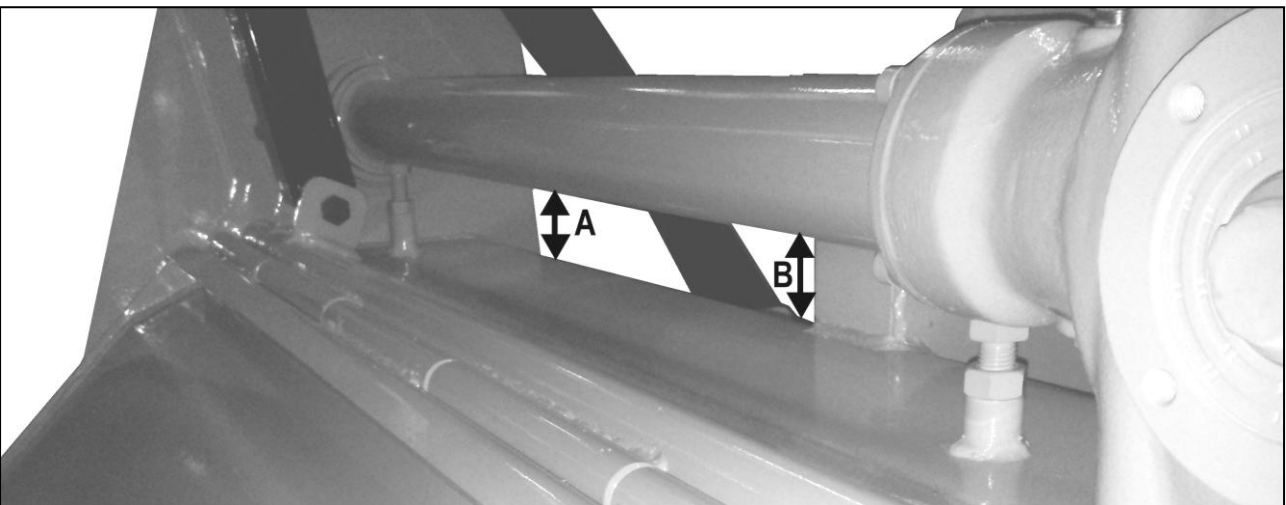

Half-shaft must always be set parallel to the frame to ensure belts run true. Distances A & B should be equal.

MAINTENANCE

All maintenance, cleaning and repair operations must be performed with the machine firmly lowered to the ground and detached from the tractor or with the PTO disconnected, engine switched off and starting key removed. For any repairs or maintenance that requires access from underneath; the machine should be firmly and safely raised and propped using suitable purpose designed supports capable of bearing the machines full weight. Care should be adopted at all times when working with or under a raised machine.

MAINTENANCE TASKS

The following preventative maintenance tasks should be performed at the timescales stated to both maximise efficiency and prolong the working life of the machine.

After first 2 hours of work - new machine or machine fitted with new belts.

- ✓ Check all nuts and bolt for tightness – *retighten if required.*
- ✓ Check belt tension and adjust if required – *refer to belt section for details of adjustment.*

Every 4 hours of work

- ✓ Lubricate grease points – *preferably whilst the machine is still warm.*

After every 8 hours of work

- ✓ Check all nuts and bolt for tightness – *retighten if required.*
- ✓ Check belt tension and adjust if required – *refer to belt section for details of adjustment.*
- ✓ Check wear and condition of flails – *replacing missing, or damaged flails immediately.*
- ✓ Check condition of safety guards – *repair or replace if not performing their function.*
- ✓ Lubricate grease points – *preferably whilst the machine is still warm.*
- ✓ Check gearbox oil level – *top up if required.*
- ✓ Check rotor – *remove foreign objects that may be fouling or lodged in the rotor.*
- ✓ Check frame and 3-point hitch – *ensure all components are in a safe working condition.*

After initial 100 hours of work with a new machine.

- ✓ Replace gearbox oil.

After every 100 hours

- ✓ Grease PTO driveshaft – *separate telescopic drive and apply grease to internal shaft.*

Every 400 hours of work or every 12 months (whichever is soonest)

- ✓ Replace gearbox oil.

Transmission Lubrication

Lubricant level should be checked on a daily basis during work and topped up if required. Checking the level is by removal of the oil level plug; if oil emerges from the plug hole the level is correct, if it does not refill to a point where the oil emerges. Replace plug and tighten before using the machine.

Gearbox oil should be replaced every 400 working hours or on an annual basis (*which ever occurs first*).

Transmission Capacity & Lubricant

Capacity; *1.7 Litres* Recommended Oil; *SAE-90 EP*

Grease Points

All grease points should be lubricated prior to work and after every 4 hours of duty using a good quality grease containing Mollbdenum Disulphate.

Recommended Grease; *Molikote or BR-II (Black or Green)*

Flail replacement

The rotor and flails should be inspected for wear or damage on a regular basis – missing, damaged or worn flails should be replaced immediately.



DANGER: Machine and tractor should be switched off and the starting key removed at all times when inspecting or maintaining the machine – Never work on a machine that is switch on and running.

Rotor Vibration

If vibration of the rotor is experienced the machine should be stopped immediately – this is often a sign that a flail is either missing or severely damaged, if this is the case do not use the machine until the problem has been rectified. If vibration continues, or occurs for no apparent reason, the rotor must be checked and, if necessary, rebalanced before using the machine again. Contact your local dealer for further advice or assistance on this subject.

TROUBLESHOOTING

| PROBLEM | POSSIBLE CAUSES | REMEDIES |
|-------------------------------------|--|------------------------------------|
| Irregular Cut | Worn, broken or missing flails | <i>Replace flails</i> |
| | RPM too low | <i>Increase RPM</i> |
| | Machine not level to the ground | <i>Correct mounting on tractor</i> |
| | Clogged material caused by excessive forward speed | <i>Reduce forward speed</i> |
| Noise | Loose bolts | <i>Check and tighten bolts</i> |
| | Damaged components | <i>Repair or replace</i> |
| Noisy gearbox | Lack of lubrication | <i>Top up oil to correct level</i> |
| | Worn gears | <i>Replace worn components</i> |
| | Worn bearings | <i>Replace worn components</i> |
| Vibration | Broken, worn or missing flails | <i>Replace flails</i> |
| | Rotor out of balance | <i>Balance or replace rotor</i> |
| | Worn rotor bearings | <i>Replace rotor bearings</i> |
| Excessive backlash in joints | Worn pins | <i>Replace pins</i> |
| Tight bearings | Bearings dirty or ungreased | <i>Clean and grease</i> |
| | Violent lowering down of machine | <i>Lower machine gently</i> |
| Belts overheating | Belts slipping on pulleys | <i>Tension belts</i> |
| | Flails contacting the ground | <i>Raise cutting height</i> |
| | Working speed too high | <i>Reduce working speed</i> |

Machine Disposal

Disposal of this machine and any of its component parts must be performed in a responsible and inoffensive manner respecting all current laws relating to this subject. Materials forming this machine that must undergo differentiated division and disposal are:

- Steel
- Mineral Oil
- Rubber
- Plastic

TORQUE SETTINGS FOR FASTENERS

The Chart below lists the correct tightening torque for fasteners. The Chart should be referred to when tightening or replacing bolts in order to determine the grade of bolt and the correct torque unless specific torque values are assigned in the text of the manual.

Recommended torque is quoted in Foot-Pounds and Newton-Metres within this manual.

The equation for conversion is 1 Nm. = 0.7376 ft.lbs.

TORQUE VALUES FOR IMPERIAL BOLTS

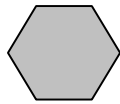
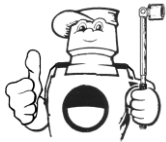

Head Marking
No Marks
Grade Two

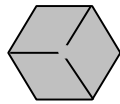

Head Marking
Three Lines
Grade Five

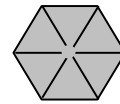

Head Marking
Six Lines
Grade Eight

NOTE:

The values in the chart apply to fasteners as received from the supplier, dry or when lubricated with normal engine oil. They DO NOT apply if special graphited, molydisulphide greases, or other extreme pressure lubricants are used. This applies to both UNF and UNC coarse threads.

| Bolt Dia. |
|-----------|
| 1/4" |
| 5/16" |
| 3/8" |
| 7/16" |
| 1/2" |
| 9/16" |
| 5/8" |
| 3/4" |
| 7/8" |
| 1" |
| 1-1/8" |
| 1-1/4" |
| 1-3/8" |
| 1-1/2" |

| Value (Dry) | |
|-------------|--------|
| ft.lb. | Nm. |
| 5.5 | 7.5 |
| 11 | 15.0 |
| 20 | 27.0 |
| 32 | 43.0 |
| 50 | 68.0 |
| 70 | 95.0 |
| 100 | 135.0 |
| 175 | 240.0 |
| 175 | 240.0 |
| 270 | 360.0 |
| 375 | 510.0 |
| 530 | 720.0 |
| 700 | 950.0 |
| 930 | 1250.0 |

| Value (Dry) | |
|-------------|--------|
| ft.lb. | Nm. |
| 9 | 12.2 |
| 18 | 25.0 |
| 33 | 45.0 |
| 52 | 70.0 |
| 80 | 110.0 |
| 115 | 155.0 |
| 160 | 220.0 |
| 280 | 380.0 |
| 450 | 610.0 |
| 675 | 915.0 |
| 850 | 115.0 |
| 1200 | 1626.0 |
| 1550 | 2100.0 |
| 2100 | 2850.0 |

| Value (Dry) | |
|-------------|--------|
| ft.lb. | Nm. |
| 12.5 | 17.0 |
| 26 | 35.2 |
| 46 | 63.0 |
| 75 | 100.0 |
| 115 | 155.0 |
| 160 | 220.0 |
| 225 | 305.0 |
| 400 | 540.0 |
| 650 | 880.0 |
| 975 | 1325.0 |
| 1350 | 1830.0 |
| 1950 | 2650.0 |
| 2550 | 3460.0 |
| 3350 | 4550.0 |

TORQUE VALUES FOR METRIC BOLTS.



Head Marking
4.8



Head Marking
8.8



Head Marking
10.9



Head Marking
12.9

| Bolt Dia. |
|-----------|
| 6mm |
| 8mm |
| 10mm |
| 12mm |
| 14mm |
| 16mm |
| 18mm |
| 20mm |
| 22mm |
| 24mm |
| 27mm |
| 30mm |

| Value (Dry) | |
|-------------|-------|
| ft.lb. | Nm. |
| 4.5 | 6.1 |
| 11 | 14.9 |
| 21 | 28.5 |
| 37 | 50.2 |
| 60 | 81.4 |
| 92 | 125.0 |
| 125 | 170.0 |
| 180 | 245.0 |
| 250 | 340.0 |
| 310 | 420.0 |
| 450 | 610.0 |
| 625 | 850.0 |

| Value (Dry) | |
|-------------|--------|
| ft.lb. | Nm. |
| 8.5 | 11.5 |
| 20 | 27.1 |
| 40 | 54.2 |
| 70 | 95.0 |
| 110 | 150.0 |
| 175 | 240.0 |
| 250 | 340.0 |
| 350 | 475.0 |
| 475 | 645.0 |
| 600 | 810.0 |
| 875 | 1180.0 |
| 1200 | 1626.0 |

| Value (Dry) | |
|-------------|--------|
| ft.lb. | Nm. |
| 12 | 16.3 |
| 30 | 40.1 |
| 60 | 81.4 |
| 105 | 140.0 |
| 165 | 225.0 |
| 255 | 350.0 |
| 350 | 475.0 |
| 500 | 675.0 |
| 675 | 915.0 |
| 850 | 1150.0 |
| 1250 | 1700.0 |
| 1700 | 2300.0 |

| Value (Dry) | |
|-------------|--------|
| ft.lb. | Nm. |
| 14.5 | 20.0 |
| 35 | 47.5 |
| 70 | 95.0 |
| 120 | 160.0 |
| 190 | 260.0 |
| 300 | 400.0 |
| 410 | 550.0 |
| 580 | 790.0 |
| 800 | 1090.0 |
| 1000 | 1350.0 |
| 1500 | 2000.0 |
| 2000 | 2700.0 |



McConnel Limited, Temeside Works, Ludlow, Shropshire SY8 1JL. England.
Telephone: 01584 873131. Facsimile: 01584 876463. www.mcconnel.com