

Publication 533
March 2008
Part No. 41571.33
Revised: 15.04.14



MAGNUM

SHREDDER MOWERS

HEAVY DUTY SERIES: 245, 270 & 300
2008 Models

Operator Manual



IMPORTANT

VERIFICATION OF WARRANTY REGISTRATION



Dealer Warranty Information & Registration Verification

It is imperative that the selling dealer registers this machine with McConnel Limited before delivery to the end user – failure to do so may affect the validity of the machine warranty.

To register machines; log onto <https://my.mcconnel.com> and select 'Machine Registration' which can be found in the 'Warranty' section of the site. **Confirm to the customer that the machine has been registered by completing the verification form below.**

Registration Verification	Serial No. <input type="text"/>
Dealer Name:	
Dealer Address:	
Customer Name:	
Date of Warranty Registration:/...../..... Dealer Signature:	

Note to Customer / Owner

Please ensure the section above has been completed and signed by the dealer to verify your machine has been registered with McConnel Limited.

IMPORTANT: During the initial 'bedding in' period of a new machine it is the customer's responsibility to regularly inspect all nuts, bolts and hose connections for tightness and re-tighten if required. New hydraulic connections occasionally weep small amounts of oil as the seals and joints settle in – where this occurs it can be cured by re-tightening the connection – *refer to torque settings chart below*. The tasks stated above should be performed on an hourly basis during the first day of work and at least daily thereafter as part of the machine's general maintenance procedure.

CAUTION: DO NOT OVER TORQUE HYDRAULIC FITTINGS AND HOSES

Torque Settings for Hydraulic Fittings

Hydraulic Hose Ends		
BSP	Setting	Metric
1/4"	18 Nm	19 mm
3/8"	31 Nm	22 mm
1/2"	49 Nm	27 mm
5/8"	60 Nm	30 mm
3/4"	80 Nm	32 mm
1"	125 Nm	41 mm
1.1/4"	190 Nm	50 mm
1.1/2"	250 Nm	55 mm
2"	420 Nm	70 mm

Port Adaptors with Bonded Seals		
BSP	Setting	Metric
1/4"	34 Nm	19 mm
3/8"	47 Nm	22 mm
1/2"	102 Nm	27 mm
5/8"	122 Nm	30 mm
3/4"	149 Nm	32 mm
1"	203 Nm	41 mm
1.1/4"	305 Nm	50 mm
1.1/2"	305 Nm	55 mm
2"	400 Nm	70 mm

WARRANTY POLICY

WARRANTY REGISTRATION

All machines must be registered, by the selling dealer with McConnel Ltd, before delivery to the end user. On receipt of the goods it is the buyer's responsibility to check that the Verification of Warranty Registration in the Operator's Manual has been completed by the selling dealer.

1. LIMITED WARRANTIES

1.01. *All mounted machines supplied by McConnel Ltd are warranted to be free from defects in material and workmanship from the date of sale to the original purchaser for a period of 12 months, unless a different period is specified.*

All Self Propelled Machines supplied by McConnel Ltd are warranted to be free from defects in material and workmanship from the date of sale to the original purchaser for a period of 12 months or 1500 hours. Engine warranty will be specific to the Manufacturer of that unit.

1.02. *All spare parts supplied by McConnel Ltd and purchased by the end user are warranted to be free from defects in material and workmanship from the date of sale to the original purchaser for a period of 6 months. All parts warranty claims must be supported by a copy of the failed part invoice to the end user. We cannot consider claims for which sales invoices are not available.*

1.03. *The warranty offered by McConnel Ltd is limited to the making good by repair or replacement for the purchaser any part or parts found, upon examination at its factory, to be defective under normal use and service due to defects in material or workmanship. Returned parts must be complete and unexamined. Pack the component(s) carefully so that any transit damage is avoided. All ports on hydraulic items should be drained of oil and securely plugged to prevent seepage and foreign body ingress. Certain other components, electrical items for example, may require particular care when packing to avoid damage in transit.*

1.04. *This warranty does not extend to any product from which McConnel Ltd's serial number plate has been removed or altered.*

1.05. *The warranty policy is valid for machines registered in line with the terms and conditions detailed and on the basis that the machines do not extend a period of 24 months or greater since their original purchase date, that is the original invoice date from McConnel Limited.*

Machines that are held in stock for more than 24 months cannot be registered for warranty.

1.06. *This warranty does not apply to any part of the goods, which has been subjected to improper or abnormal use, negligence, alteration, modification, fitment of non-genuine parts, accident damage, or damage resulting from contact with overhead power lines, damage caused by foreign objects (e.g. stones, iron, material other than vegetation), failure due to lack of maintenance, use of incorrect oil or lubricants, contamination of the oil, or which has served its normal life. This warranty does not apply to any expendable items such as blades, belts, clutch linings, filter elements, flails, flap kits, skids, soil engaging parts, shields, guards, wear pads, pneumatic tyres or tracks.*

1.07. *Temporary repairs and consequential loss - i.e. oil, downtime and associated parts are specifically excluded from the warranty.*

1.08. *Warranty on hoses is limited to 12 months and does not include hoses which have suffered external damage. Only complete hoses may be returned under warranty, any which have been cut or repaired will be rejected.*

1.09. *Machines must be repaired immediately a problem arises. Continued use of the machine after a problem has occurred can result in further component failures, for which McConnel Ltd cannot be held liable, and may have safety implications.*

1.10. *If in exceptional circumstances a non McConnel Ltd part is used to effect a repair, warranty reimbursement will be at no more than McConnel Ltd's standard dealer cost for the genuine part.*

- 1.11. *Except as provided herein, no employee, agent, dealer or other person is authorised to give any warranties of any nature on behalf of McConnell Ltd.*
- 1.12. *For machine warranty periods in excess of 12 months the following additional exclusions shall apply:*
 - 1.12.1. *Hoses, exposed pipes and hydraulic tank breathers.*
 - 1.12.2. *Filters.*
 - 1.12.3. *Rubber mountings.*
 - 1.12.4. *External electric wiring.*
 - 1.12.5. *Bearings and seals*
 - 1.12.6. *External Cables, Linkages*
 - 1.12.7. *Loose/Corroded Connections, Light Units, LED's*
 - 1.12.8. *Comfort items such as Operator Seat, Ventilation, Audio Equipment*
- 1.13. *All service work, particularly filter changes, must be carried out in accordance with the manufacturer's service schedule. Failure to comply will invalidate the warranty. In the event of a claim, proof of the service work being carried out may be required.*
- 1.14. *Repeat or additional repairs resulting from incorrect diagnosis or poor quality previous repair work are excluded from warranty.*

NB Warranty cover will be invalid if any non-genuine parts have been fitted or used. Use of non-genuine parts may seriously affect the machine's performance and safety. McConnell Ltd cannot be held responsible for any failures or safety implications that arise due to the use of non-genuine parts.

2. REMEDIES AND PROCEDURES

- 2.01. *The warranty is not effective unless the Selling Dealer registers the machine, via the McConnell web site and confirms the registration to the purchaser by completing the confirmation form in the operator's manual.*
- 2.02. *Any fault must be reported to an authorised McConnell Ltd dealer as soon as it occurs. Continued use of a machine, after a fault has occurred, can result in further component failure for which McConnell Ltd cannot be held liable.*
- 2.03. *Repairs should be undertaken within two days of the failure. Claims submitted for repairs undertaken more than 2 weeks after a failure has occurred, or 2 days after the parts were supplied will be rejected, unless the delay has been authorised by McConnell Ltd. Please note that failure by the customer to release the machine for repair will not be accepted as a reason for delay in repair or submitting warranty claims.*
- 2.04. *All claims must be submitted, by an authorised McConnell Ltd Service Dealer, within 30 days of the date of repair.*
- 2.05. *Following examination of the claim and parts, McConnell Ltd will pay, at their discretion, for any valid claim the invoiced cost of any parts supplied by McConnell Ltd and appropriate labour and mileage allowances if applicable.*
- 2.06. *The submission of a claim is not a guarantee of payment.*
- 2.07. *Any decision reached by McConnell Ltd. is final.*

3. LIMITATION OF LIABILITY

- 3.01. *McConnell Ltd disclaims any express (except as set forth herein) and implied warranties with respect to the goods including, but not limited to, merchantability and fitness for a particular purpose.*
- 3.02. *McConnell Ltd makes no warranty as to the design, capability, capacity or suitability for use of the goods.*
- 3.03. *Except as provided herein, McConnell Ltd shall have no liability or responsibility to the purchaser or any other person or entity with respect to any liability, loss, or damage caused or alleged to be caused directly or indirectly by the goods including, but not limited to, any indirect, special, consequential, or incidental damages resulting from the use or operation of the goods or any breach of this warranty. Notwithstanding the above limitations and warranties, the manufacturer's liability hereunder for damages incurred by the purchaser or others shall not exceed the price of the goods.*
- 3.04. *No action arising out of any claimed breach of this warranty or transactions under this warranty may be brought more than one (1) year after the cause of the action has occurred.*

4. MISCELLANEOUS

- 4.01. McConnel Ltd may waive compliance with any of the terms of this limited warranty, but no waiver of any terms shall be deemed to be a waiver of any other term.*
- 4.02. If any provision of this limited warranty shall violate any applicable law and is held to be unenforceable, then the invalidity of such provision shall not invalidate any other provisions herein.*
- 4.03. Applicable law may provide rights and benefits to the purchaser in addition to those provided herein.*

McConnel Limited

FLAIL MOWER & TRACTOR PRE-OPERATION INSPECTION



A daily equipment inspection of machine and tractor should be conducted before the equipment is used.

Use the inspection sheets on the following pages to assist with these daily inspections. Damaged or missing guards should be repaired or replaced before operating the mower. Failure to repair or replace damaged guards can result in objects being thrown from the mower and possibly hitting the operator and/or bystanders.

Inspect the Mower for Safe Operating Condition

- Make sure the driveline guards and shielding are in place and in good repair.
- Inspect the chain guards, flexible and/or solid deflector thrown object shielding to assure that they are in place on the front and rear of the mower deck and in good repair. Repair or replace any damaged or missing thrown object shields.
- Ensure the mower cutting height is set high enough to reduce the possibility of the mower blades contacting the ground. Actual height will be dependent on the ground conditions. Increase the height when working in rough or undulating conditions.
- Inspect for broken, chipped, bent, missing, or severely worn blades. Replace damaged blades before operating the mower. Ensure the blade retaining bolts and fasteners are secure and tight.
- Lubricate the driveline universal joints and telescoping members daily.
- Inspect the wheel lug bolt/nuts to assure that they are tight.
- If mower is equipped with pneumatic tyres, make sure they have the required air pressure.
- Inspect for worn or damaged decals and safety instructions. Replace any unreadable, damaged or missing safety decals.
- Follow the operator's manual(s) inspection and maintenance instructions for lubricating parts, and keeping thrown object shielding, driveline guards, rotating parts shields, mower blades and decals in good repair.

Inspect the Tractor for Safe Operating Condition

- Inspect the controls, lights, SMV's (Slow Moving Vehicle sign), seat belts, and ROPS to ensure they are in place and in good working order.
- Ensure tyres, wheels, lug bolts/nuts are in good condition.
- Make sure the tractor brakes and steering are in proper operating condition.
- Follow the operator's manual(s) inspection and maintenance procedures for keeping the tractor in good and safe condition before operating.

Copies of the inspection sheets on the following pages should be retained in this manual for reference; two sets are included to allow removal of one set for photocopying purposes. Alternatively, these inspection sheets can be download from our website via the QR code or using the link below;
<https://my.mcconnel.com/service/pre-operation-inspection-documents/>





FLAIL MOWER PRE-OPERATION INSPECTION

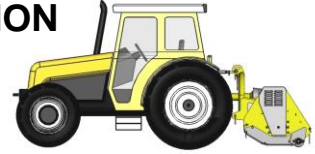

Mower ID Date: Shift:



WARNING: Before conducting the inspection, make sure the tractor engine is off, the key removed, all rotation has stopped and the tractor is in park with the parking brake engaged. Make sure the mower is resting on the ground or is securely blocked up and supported and all hydraulic pressure has been relieved.

Item	Condition at start of shift	Specific Comments if not O.K.
The operator's manual is in the canister on the mower.		
All warning decals are in place, clean and legible.		
The hydraulic cylinder pins are tight and correctly secured.		
The hydraulic cylinder hose connections are tight.		
There are no oil leaks.		
There are no damaged hoses.		
Flails are not missing chipped, broken or excessively worn.		
The flail bolts are tight.		
The front and rear flaps are fitted and in good condition.		
The skid shoes are in good condition and tight.		
The rotor bearings are in good condition and greased.		
The roller bearings are in good condition and greased.		
There are no cracks or holes in flail casing.		
The drive line/gearbox shaft guard is in good condition.		
The drive line/gearbox shaft guard is correctly secured.		
Driveline telescoping members & u-joints are lubricated.		
Driveline yokes are securely attached to tractor and mower.		
All linkage mounting pins are securely fastened.		

Operators Signature:

DO NOT OPERATE AN UNSAFE TRACTOR OR MACHINE



TRACTOR PRE-OPERATION INSPECTION



Power Arm ID Date: Shift:



WARNING: Before conducting the inspection, make sure the tractor engine is off, the key removed, all rotation has stopped and the tractor is in park with the parking brake engaged. Ensure any implement attached to the tractor is firmly on the ground.

Item	Condition at start of shift	Specific Comments if not O.K.
The flashing lights function properly.		
All lights are clean and working correctly.		
All cab windows are clean and wipers working correctly.		
The SMV sign, where required, is clean and visible.		
The tyres are in good condition with correct pressure.		
The wheel nuts are tight.		
The tractor brakes are in good condition.		
The steering linkage is in good condition.		
There are no visible oil leaks.		
The hydraulic controls function properly.		
The ROPS or ROPS cab is in good condition.		
The seatbelt is in place and in good condition.		
The 3-point hitch is in good condition.		
The drawbar/pick up hook is secure and in good condition.		
The PTO master shield is in place.		
The engine oil level is full.		
The brake fluid level is full.		
The power steering fluid level is full.		
The fuel level is adequate.		
The engine coolant fluid level is full.		
The radiator and oil cooler are free of debris.		
The air filter is in good condition.		

Operators Signature:

DO NOT OPERATE AN UNSAFE TRACTOR OR MACHINE



FLAIL MOWER PRE-OPERATION INSPECTION

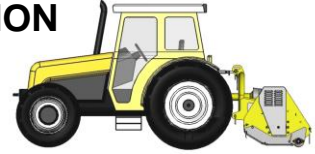

Mower ID Date: Shift:



WARNING: Before conducting the inspection, make sure the tractor engine is off, the key removed, all rotation has stopped and the tractor is in park with the parking brake engaged. Make sure the mower is resting on the ground or is securely blocked up and supported and all hydraulic pressure has been relieved.

Item	Condition at start of shift	Specific Comments if not O.K.
The operator's manual is in the canister on the mower.		
All warning decals are in place, clean and legible.		
The hydraulic cylinder pins are tight and correctly secured.		
The hydraulic cylinder hose connections are tight.		
There are no oil leaks.		
There are no damaged hoses.		
Flails are not missing chipped, broken or excessively worn.		
The flail bolts are tight.		
The front and rear flaps are fitted and in good condition.		
The skid shoes are in good condition and tight.		
The rotor bearings are in good condition and greased.		
The roller bearings are in good condition and greased.		
There are no cracks or holes in flail casing.		
The drive line/gearbox shaft guard is in good condition.		
The drive line/gearbox shaft guard is correctly secured.		
Driveline telescoping members & u-joints are lubricated.		
Driveline yokes are securely attached to tractor and mower.		
All linkage mounting pins are securely fastened.		

Operators Signature:

DO NOT OPERATE AN UNSAFE TRACTOR OR MACHINE



TRACTOR PRE-OPERATION INSPECTION



Power Arm ID Date: Shift:



WARNING: Before conducting the inspection, make sure the tractor engine is off, the key removed, all rotation has stopped and the tractor is in park with the parking brake engaged. Ensure any implement attached to the tractor is firmly on the ground.

Item	Condition at start of shift	Specific Comments if not O.K.
The flashing lights function properly.		
All lights are clean and working correctly.		
All cab windows are clean and wipers working correctly.		
The SMV sign, where required, is clean and visible.		
The tyres are in good condition with correct pressure.		
The wheel nuts are tight.		
The tractor brakes are in good condition.		
The steering linkage is in good condition.		
There are no visible oil leaks.		
The hydraulic controls function properly.		
The ROPS or ROPS cab is in good condition.		
The seatbelt is in place and in good condition.		
The 3-point hitch is in good condition.		
The drawbar/pick up hook is secure and in good condition.		
The PTO master shield is in place.		
The engine oil level is full.		
The brake fluid level is full.		
The power steering fluid level is full.		
The fuel level is adequate.		
The engine coolant fluid level is full.		
The radiator and oil cooler are free of debris.		
The air filter is in good condition.		

Operators Signature:

DO NOT OPERATE AN UNSAFE TRACTOR OR MACHINE

LIST OF CONTENTS

General Information	1
Machine Description & Purpose of Use	2
Machine Identification	2
Technical Data	2
Technical Specifications	3
Safety Information	4
Safety Decals	5
Vehicle / Tractor Preparation	6
Machine Attachment	7
PTO Shaft	8
Pre-Operational Checks	8
Setting Up and Adjustment	9
Drive Belts	10
Operation	11
Detachment and Storage	12
Maintenance	13
Troubleshooting	15

GENERAL INFORMATION

Always read this manual before fitting or operating the machine – whenever any doubt exists contact your dealer or the McConnel Service Department for advice and assistance.

Use only McConnel Genuine Service Parts on McConnel Equipment and Machines

DEFINITIONS – The following definitions apply throughout this manual:

WARNING

An operating procedure, technique etc., which –
can result in personal injury or loss of life if not observed carefully.

CAUTION

An operating procedure, technique etc., which –
can result in damage to either machine or equipment if not observed carefully.

NOTE

An operating procedure, technique etc., which –
is considered essential to emphasis.

LEFT AND RIGHT HAND

This term is applicable to the machine when attached to the tractor and is viewed
from the rear – this also applies to tractor references.

MACHINE & DEALER INFORMATION

Record the Serial Number of your machine on this page and always quote this number when ordering parts. Whenever information concerning the machine is requested remember also to state the make and model of tractor to which the machine is fitted.

Machine Serial Number:	Installation Date:
Machine Model details:	
Dealer Name:	
Dealer Address:	
Dealer Telephone No:	
Dealer Email Address:	

MACHINE DESCRIPTION & PURPOSE OF USE

The Magnum 245, 270 & 300 series of machines are '3-point linkage' tractor mounted heavy duty professional mowers designed primarily for the mulching of maize, grasses, bushes, branches, vines, and general crop residues. Their strong, tough construction with working widths of 2.4, 2.7 or 3.0m and offset capability of over 0.5m makes them ideal for maintenance use in all green areas, vineyards, orchards, on verges and in scrubland by farmers and contractors alike.

These machines should only be used to perform tasks for which they were designed – use of the machine for any other function may be both dangerous to persons and damaging to components and is therefore not advisable.

MACHINE IDENTIFICATION

Each machine is fitted with an identification plate with the following information:

1. Machine (Part Number)
2. Machine Serial No.
3. Machine Weight

When ordering spares or replacement parts from your local dealer it is important to quote both Part Number and Serial Number as stated on the identification plate so the machine and model can be quickly and correctly identified.



Machine Identification Plate

TECHNICAL DATA

COMPONENT IDENTIFICATION

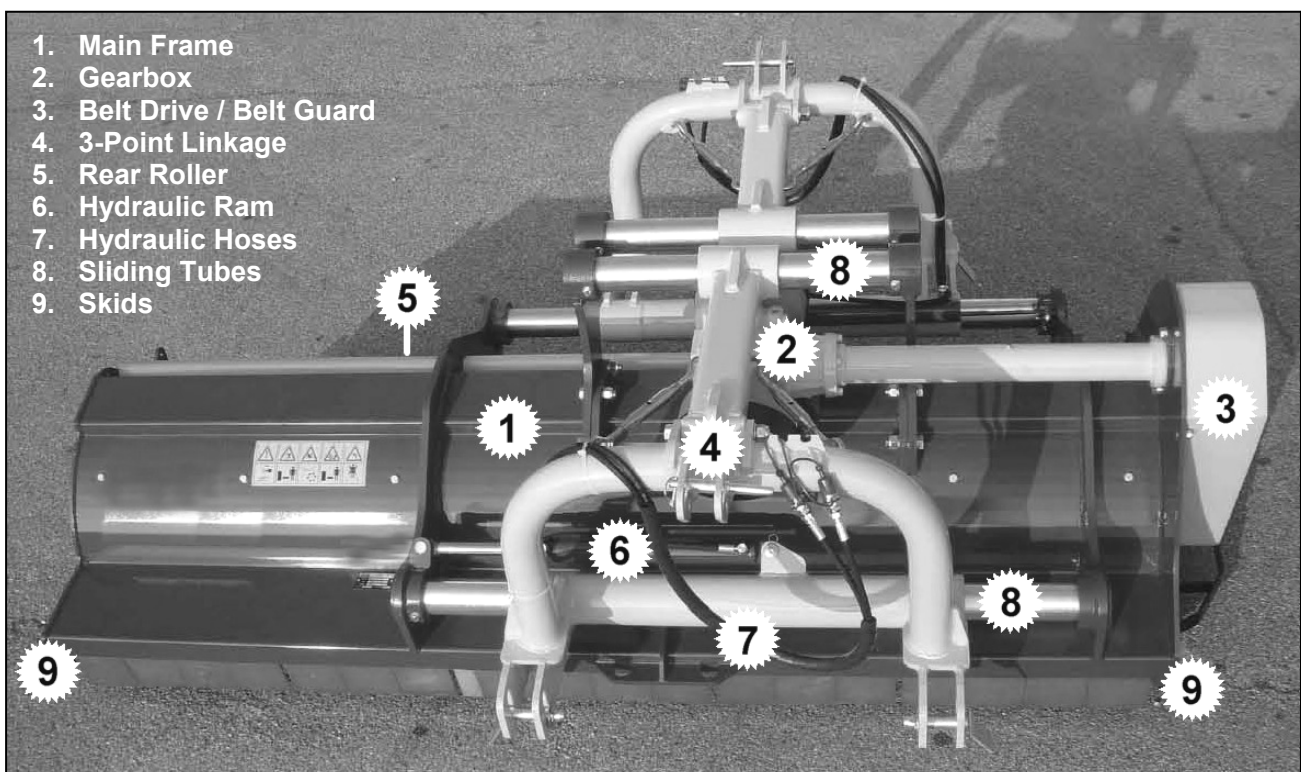

Combi model with double linkage option illustrated

TECHNICAL SPECIFICATIONS

SPECIFICATION	Model 245	Model 270	Model 300
Working Width	2450mm	2700mm	3000mm
Tractor Power Requirement	68-80 HP	75-100 HP	90-130 HP
PTO RPM (* Option)	540 /1000* RPM	540 /1000* RPM	540 /1000* RPM
Hammer Blades	26	28	32
Y-Blades	78	84	96
Machine Weight	880kg	950kg	1020kg
Offset Capability	530mm	530mm	530mm
Linkage Type	3-Point (Cat. II)	3-Point (Cat. II)	3-Point (Cat. II)
Machine Width (Total)	2510mm	2670mm	3000mm

MACHINE BUILDS

Standard machines are rear mounted left hand build, optional builds right handed, front mounted or Combi models.

MACHINE RPM

Standard machines are 540RPM with 1000RPM optional on request.

OPTIONAL EQUIPMENT

The standard flails fitted to the machine are the hammer blade type, Y-blade flails are optional. The cutting capability of the each particular type of flail will be dependant on the sort, hardness, and density of the material being cut, but in general the following cutting thicknesses apply:

Y-blade flails – for materials up to a maximum of 30mm diameter.

Hammer flails – for materials up to a maximum of 50mm diameter.

NOISE LEVEL

The sound level of this machine, as measured at the operator's ear, is within the range of 70 to 90 dB when the rear window of the tractor is open. We recommend that ear protectors are worn and the tractor windows kept closed at all times when operating this machine.

SAFETY GUARDS

The photo opposite indicates the locations of the machine safety guards – *the machine must never be operated with any of these guards missing or damaged.*

1. PTO Shaft Guard
2. Belt Guard
3. Front Flap Guard
4. Side Guard
5. Rear Rubber Guard

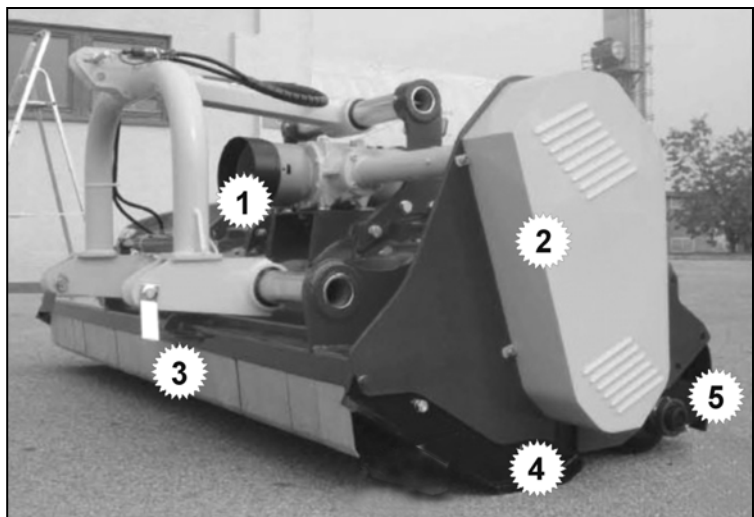

SAFETY INFORMATION

General safety rules:

- ▲ Always read and follow the instructions for the use and maintenance of the machine before carrying out any work operations or servicing tasks.
- ▲ Improper use of the machine is both highly dangerous to persons and damaging to the machine components – only use the machine for its designated task.
- ▲ Both operators and the maintenance fitters should be familiar with the machine and fully aware of dangers surrounding improper use or incorrect repairs.
- ▲ Before starting, checks to both tractor and machine must be carried out as regards: functionality, road safety, accident prevention rules.
- ▲ Even when using the machine correctly, stones or other objects may be thrown a long distance. Therefore nobody must stand within the danger area. Special attention must be paid when working near roads or buildings.
- ▲ Use tractor's fitted with safety cabs.
- ▲ The condition of flails and of machine guards must be checked before beginning the daily work - they must be replaced if damaged or missing before you use the machine.
- ▲ During checks or repairs, make sure nobody could start the machine by mistake.
- ▲ Never wear loose or fluttering clothes.
- ▲ Never carry passengers on the tractor.
- ▲ Never carry passengers on the machine.
- ▲ Never connect the power takeoff with the engine running.
- ▲ Never approach the machine until the rotor has completely stopped.
- ▲ Do not enter the working zone of the PTO shaft. It is dangerous to approach the rotating parts of a machine.
- ▲ Keep the PTO shaft guard in good condition.
- ▲ Before starting, check the surrounding area for the likely presence of children and/or animals.
- ▲ Do not stand near the machine when it is operating.
- ▲ The PTO shaft must be assembled and disassembled only with the engine stopped and the starting key removed.
- ▲ Before connecting the power takeoff, check that the speed and the rotational direction correspond to those of the machine.
- ▲ Immediately replace missing or damaged safety decals.
- ▲ Before leaving the tractor with the machine attached, proceed as follows:
 1. Disconnect the power takeoff,
 2. Put the machine steadily on the ground using the tractor's hydraulic lift.
 3. Apply the hand brake and, if the ground is steeply sloping, wedge the tractor.
 4. Remove the starting key.

Transportation Safety

- ▲ In transport, reduce speed, especially on bumpy roads, the weight of the machine may render driving difficult and damage the machine itself.
- ▲ Ensure the levers that operate the hydraulic lift are locked, to avoid the lowering of the machine during transport.
- ▲ When driving on public roads, respect all road rules in force.
- ▲ Never transport the machine with the rotor running, even for short distances.

Operating Safety

- ▲ Pay special attention when working with the machine not to touch fixed objects such as road drain, walls, shafts, kerbs, guard rails, tracks etc. This could cause the breakage of the flails, which would be thrown out of the machine at very high speed.
- ▲ If wires, ropes or chains should become entangled in the rotor stop immediately to prevent damage or dangerous situations; stop the rotor and the tractor, take out the starting key. Put working gloves on; clear the rotor with the aid of pliers or shears. Do not try to disentangle by inverting the rotational direction of the rotor.
- ▲ Do not use the machine when excessive vibration is experienced, as this may cause breakage and serious damage - find the cause of the vibration and eliminate it before using the machine again.

Although the information given here covers a wide range of safety subjects, it is impossible to predict every eventuality that can occur under differing circumstances whilst operating this machine. No advice given here can replace 'good common sense' and 'total awareness' at all times, but will go a long way towards the safe use of your McConnel machine.

SAFETY DECALS



1.

1. Always switch machine off, remove starting key and read instruction manual before performing service or maintenance work on the machine.



2.

2. Keep a safe distance from the machine at all times - risk from projection of objects.



3.

3. Risk of hand injury – always ensure all guard are fitted and in place when machine is operating.



4.

4. Risk of feet injury – keep at a safe distance from the machine when it is operating.



5.

5. Never stand or ride on the machine.

VEHICLE / TRACTOR PREPARATION

We recommend vehicles are fitted with cabs using 'safety glass' windows and protective guarding when used with our machines.

Fit Operator Guard (part no. 73 13 324) using the hooks provided. Shape the mesh to cover all vulnerable areas.

Remember the driver must be looking through mesh and/or polycarbonate glazing when viewing the machine in all positions - unless the vehicle/ cab manufacturer can demonstrate that the penetration resistance is equivalent to, or higher than, that provided by mesh/polycarbonate glazing. If the tractor has a roll bar only, a frame must be made to carry both mesh and polycarbonate glazing. The operator should also use personal protective equipment to reduce the risk of serious injury such as; eye protection (mesh visor to EN1731 or safety glasses to EN166), hearing protection to EN352, safety helmet to EN297, gloves, filter mask and high visibility clothing.

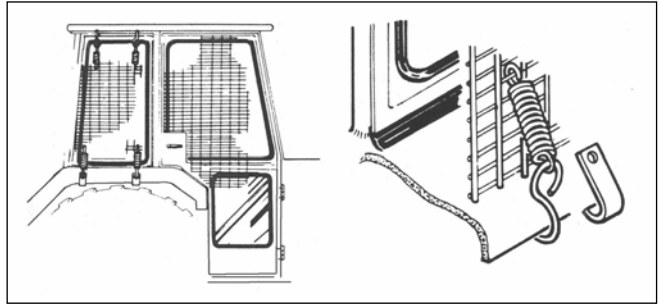

Vehicle Ballast

It is imperative when attaching 'third-party' equipment to a vehicle that the maximum possible stability of the machine and vehicle combination is achieved – this can be accomplished by the utilisation of 'ballast' in order to counter-balance the additional equipment added.

Front weights may be required for rear mounted machines to place 15% of total outfit weight on the front axle for stable transport on the road and to reduce 'crabbing' due to the drag of the cutting unit when working on the ground.

Where a machine works to the side of the tractor rear weights may be required to maintain a reasonable amount of rear axle load on the opposing wheel.

All factors must be addressed in order to match the type and nature of the equipment added to the circumstances under which it will be used - factors that effect stability are:

- Centre of gravity of the tractor/machine combination.
- Geometric conditions, e.g. position of the cutting head and ballast.
- Weight, track width and wheelbase of the tractor.
- Acceleration, braking, turning and the relative position of the cutting unit during these operations.
- Ground conditions, e.g. slope, grip, load capability of the soil/surface.
- Rigidity of implement mounting.

Suggestions to increase stability:

- Increasing rear wheel track - *a vehicle with a wider wheel track is more stable.*
- Ballasting the wheel; it is preferable to use external weights but liquid can be added to around 75% of the tyre volume – water with anti-freeze or the heavier Calcium Chloride alternative can be used.
- Addition of weights – care should be taken in selecting the location of the weights to ensure they are added to a position that offers the greatest advantage.
- Front axle locking, check with tractor manufacturer.

The advice above is offered as a guide for stability only and is not a guide to vehicle strength. It is therefore recommended that you consult your vehicle manufacturer or local dealer to obtain specific advice on this subject, additionally advice should be sought from a tyre specialist with regard to tyre pressures and ratings suitable for the type and nature of the machine you intend to fit.

ATTACHING THE MACHINE TO THE TRACTOR

Attachment of the machine to the tractor should always be performed on a firm level site.

Linkage Points

A – Lower Attachment Points (Linkage Arms)

B – Upper Attachment Point (Top Link)

Attachment to Tractor

Position the tractor's lower linkage at the same height as the machine's lower attachment points – indicated 'A' in the photo opposite.

Remove the machine lower linkage pins from location 'A'.

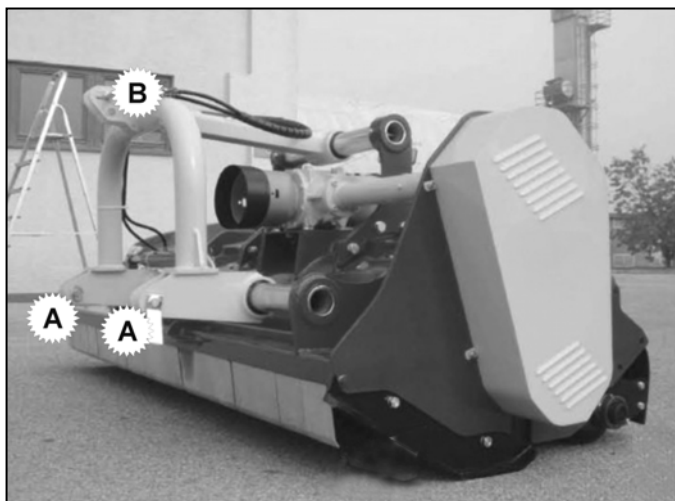

Carefully manoeuvre the tractor squarely to the machine and into its position within the attachment points – fine adjustment of the tractor lower linkage height may be necessary to correctly position the linkage and permit refitting of the linkage pins.

Insert linkage pins at location 'A' and secure in position with locking clips.

Fit top link to upper attachment point 'B'.

Important Note: The upper linkage offers the choice of 2 attachment points for differing working conditions; fixed or floating – select the correct attachment point for the working mode required. Refer to Setup and Adjustment section for additional details on this subject.

Raise the machine on the tractor's hydraulics and adjust top link so that the machine is parallel to the ground.

Fit and adjust check chains and/or stabiliser bars to lock the machine into a central position on the tractor.

Connect hydraulic hoses to the tractor's service.

Fit PTO Shaft and attach torque chains to a suitable location – refer to following page for details of PTO measurement and shaft length adjustment.

Pre-Operational Checks

Before commencing work with the machine the following checks should be performed:

- Make a visual inspection of the machine to ensure it is in good operational condition.
- Check all safety guarding is in position and in full working order.
- Check rotor for missing or damaged flails and replace if required.
- Check all greasing points are well lubricated.
- Check gearbox oil level.
- Check belt tension and adjust if required.
- Check PTO speed and direction match that of the machine.

PTO SHAFT

PTO SHAFT MEASUREMENT

Measure the PTO shaft and cut to the dimension shown – the finished length of the PTO shaft should be 75mm (3") less than the measured distance 'A' - between tractor shaft and gearbox stub shaft - to enable fitting.

NOTE: For subsequent use with different tractors measure again, there must be a minimum shaft overlap of 150mm (6").

Fit PTO in position and attach the torque chains to a convenient location to prevent the shaft guards from rotating.

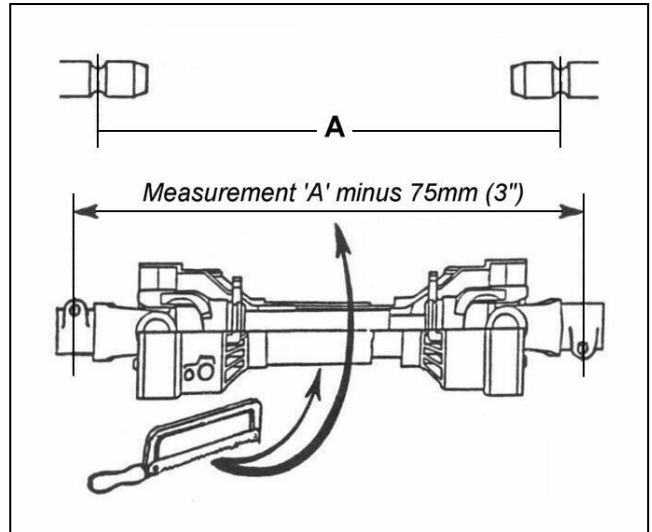

PTO SHAFT LENGTH ADJUSTMENT

1. Shorten outer plastic tube to 40mm less than the shortest envisaged shaft length.
2. Remove the marked tube.
3. Remove same length from inner plastic tube and metal shaft profiles (inner and outer).
4. De-burr all edges and remove 'swarf' to ensure smooth operation.

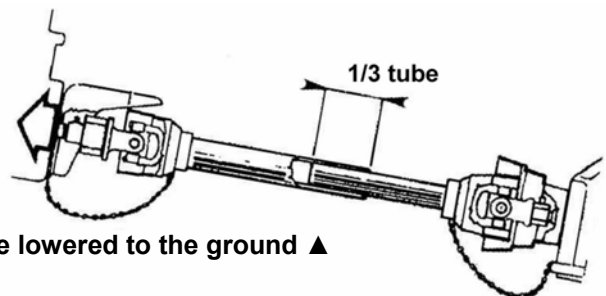
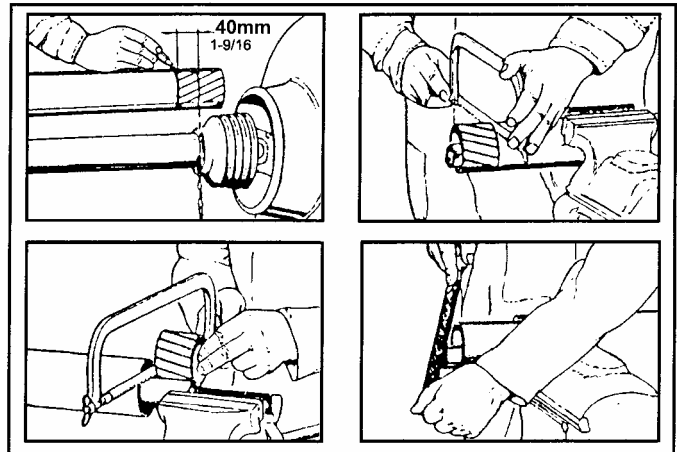

Approximate overlap length of PTO shaft with machine lowered to the ground ▲

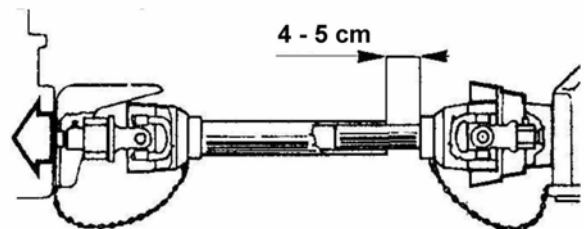

Approximate gap length of PTO protection tube with machine in working position ▲

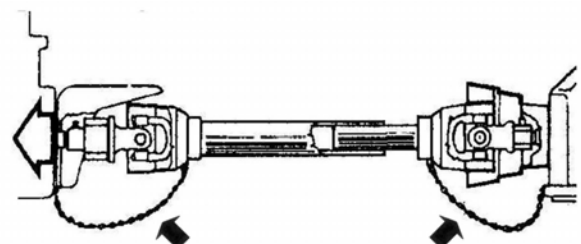

Fit torque chains to shaft guards to prevent rotation ►

SETTING UP AND ADJUSTMENT

TOP LINKAGE

The upper linkage of the machine offers the choice of 2 attachment points for specific types of working conditions; the choices allow either fixed or floating attachment – refer to photo below.

Floating position (B1) should always be used when working on hilly or uneven terrain to protect the machine and linkage from damage.

Fixed position (B2) may be used when working on even level terrain such as playing fields and other similar areas that present a lower degree of stress on the linkage.

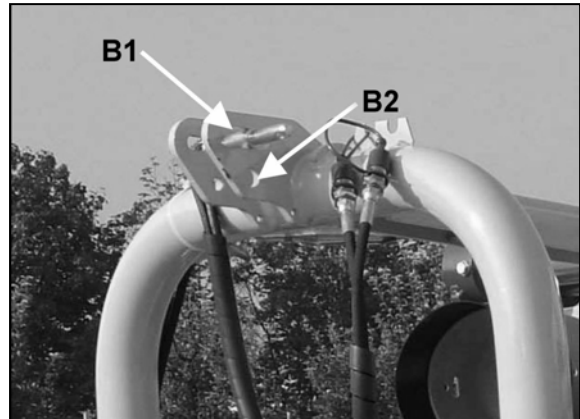

Upper linkage connection positions ►

WARNING: Always use top linkage floating position (B1) when working on hilly, sloping or undulating terrain.

CUTTING HEIGHT

The height of cut is dependent on working conditions and volume of material. The cutting height can be regulated with the hydraulic system on the tractor and/or rear roller adjustment – see photo opposite. The minimum height of cut should be between 1 – 3cm.

NOTE: The machine must always run on the rear roller not the side skids – side skids are a protection feature and in normal working conditions remain clear of the ground.

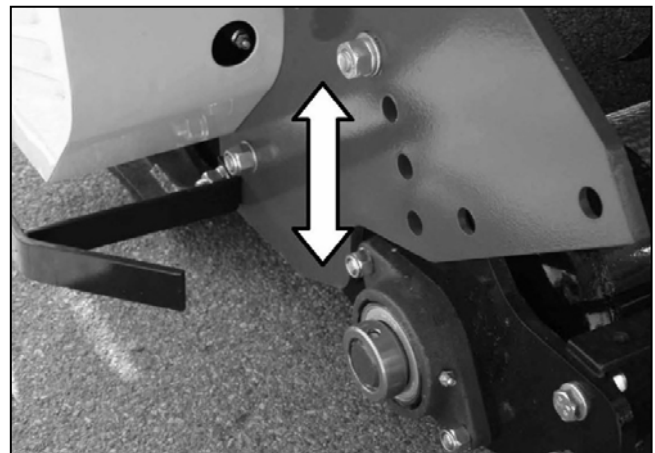

WARNING: Do not allow the rotor flails to contact the ground - set roller height to allow a minimum flail to ground clearance of 1 to 3cm.

OFFSETTING

As standard these machines are equipped with hydraulic offsetting to allow for work beyond the width of the tractor - adjustment to the required position can be carried out from the tractor cab by operation of the hydraulic sideshift ram. The maximum offset capability is 530mm. When operating the offset feature the machine must be raised clear of the ground to allow for free sideways movement.

Hydraulic Offsetting Ram ►



WARNING: Always raise the machine clear of the ground before operation of the offset feature.

DRIVE BELTS

Power from the tractor via the machines gearbox and half-shaft is transferred to the rotor through sets of belts - *the 245 model employs a 4 belt system and the 270 and 300 models employ a 5 belt system.* Correct tensioning of the belts is required for both optimal operation of the machine and long lasting belt life – in order to ensure correct belt tension the machines are fitted with automatic belt tensioning.

Belt Tensioner

Machines are fitted as standard with an automatic belt tensioning system. The system consists of a spring tensioned arm and strain pulley that permanently runs on the belts exerting sufficient pressure to keep the belts correctly tensioned.

No adjustment or maintenance will be required on the belt tensioning system other than routine inspection and general cleaning of components when inspecting belt wear.

WARNING: Checking of belts and drive components should only be carried out with tractors engine switched off, starting key removed and the PTO shaft disconnected. Never attempt to run the machine with the belt guard removed.

Belt Tensioning System ►

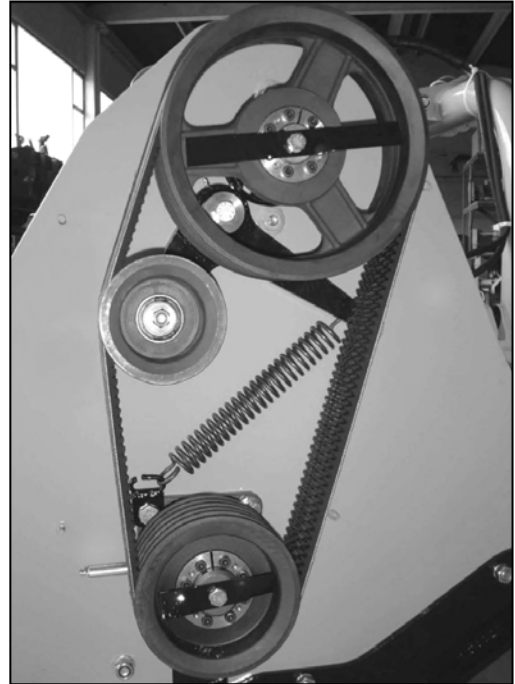

Machine RPM

As standard all units are built as 540rpm machines, but on request can be built and supplied as 1000rpm. The particular build required should be specified when ordering the machine.

Before operating the machine always ensure the machine rpm is compatible with the tractor PTO speed – this is particularly important on tractors that have different PTO speeds front and rear.

WARNING: Always check machine and tractor PTO speeds are compatible before using the machine.

Flail Types

Two types of flails are available for use with these machines – as standard machines are supplied with hammer flails, Y-Blade flails are an option. The photos below show the two types of flails:

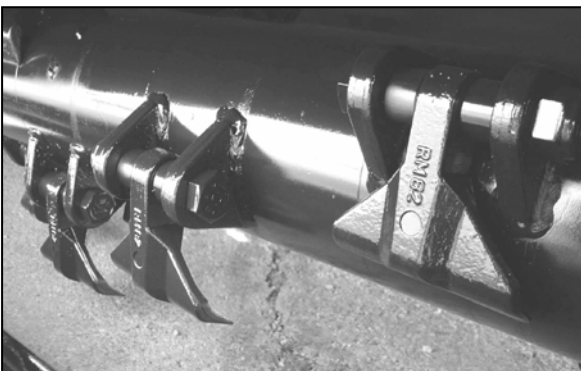

Hammer Flails

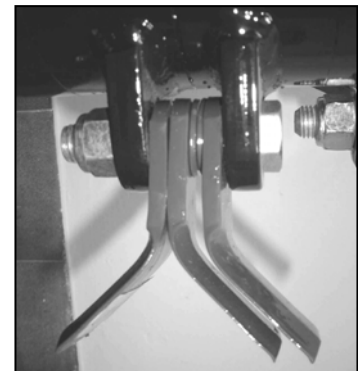

Y-Blade Flails

OPERATION

Ensure that the operator is suitably qualified to use a machine of this nature and that they have fully read and understood this manual - they should be aware of all safety aspects relating to the safe use of the machine. It is advisable that all 'first time' operators practice using the machine in a clear safe area prior to work in order to familiarise themselves with its operation.

After the initial first 2 hours of work with a new machine, nuts and bolts should be checked for tightness – *tightened if required.*

Prior to starting work the area should be checked for dangerous objects such as large stones, wood, wire, glass etc. – hazardous objects should be removed from the area prior to operation with the machine. The location of unmovable or natural hazards should be noted, or if necessary 'marked', to indicate to the operator that the area should either be avoided or additional caution adopted whilst working around the hazard.

Starting Work

With the machine switched off, lower it into a position approximately 10cm above the ground, start the machine and allow it to build up to the correct working speed before gently lowering the it onto the ground - the machine is now in its work position and forward travel can begin.

Forward Speed

The forward working speed will depend on the working conditions and nature of the material being cut. Optimal speed will be in the region of 3-8 km/h (2-5 mph).



Optimal forward working speed 3-8 km/h (2-5mph)



Raise the machine before turning or reversing

Reversing & Turning

When reversing or turning the unit the machine must always be lifted clear of the ground to avoid damage.

Transport

The following must be observed at all times when transporting the machine:

- Machine must always be switched off.
- Machine must be raised and placed into its central position.
- Speed must be kept to a minimum especially on bumpy roads or terrain.
- Always abide with local laws and road regulations.
- Be aware of the machines width.

DETACHMENT & STORAGE

Detaching the machine from the tractor

- Removal of the machine should be performed on a firm level site. The procedure for detachment is as follows:
- Place the machine in its central position.
- Gently lower the machine fully to the ground.
- Switch off the tractor and remove its starting key.
- Detach hydraulic hoses from the tractor service and stow them neatly on the machine.
- Remove the PTO driveshaft.
- 'Chock' the rear roller to prevent movement of the machine during the detachment procedure and whilst in storage.
- Remove the top link and both pins from the lower attachment points.
- Carefully and slowly drive the tractor clear of the machine.
- Clean and lubricate the machine in preparation for next use.

Storage

For extended periods of storage it is advisable that the machine be kept in a clean dry environment protected from the elements to avoid risk of corrosion. The machine should be thoroughly cleaned and lubricated prior to storage. At this point it is good practice to check the machine for worn or damaged components - any parts that require replacing should be ordered and fitted at the earliest opportunity so the machine is fully prepared for the next seasons work.

MAINTENANCE

All maintenance, cleaning and repair operations must be performed with the machine firmly lowered to the ground and detached from the tractor or with the PTO disconnected, engine switched off and starting key removed. For any repairs or maintenance that requires access from underneath, the machine should be firmly and safely raised and propped using suitable purpose designed supports capable of bearing the machines full weight. Care should be adopted at all times when working with or under a raised machine.

MAINTENANCE TASKS

The following preventative maintenance tasks should be performed at the timescales stated to both maximise efficiency and prolong the working life of the machine.

After first 2 hours of work - new machine or machine fitted with new belts.

- ✓ Check all nuts and bolt for tightness – *retighten if required.*
- ✓ Check belts condition and taper locks– *retighten if required.*

After every 8 hours of work

- ✓ Check all nuts and bolt for tightness – *retighten if required.*
- ✓ Check belts and taper locks – *retighten if required.*
- ✓ Check wear and condition of flails – *replacing missing, or damaged flails immediately.*
- ✓ Check condition of safety guards – *repair or replace if not performing their function.*
- ✓ Lubricate grease points – *see below for locations of the machines grease points.*
- ✓ Check gearbox oil level – *top up if required.*
- ✓ Check rotor – *remove foreign objects that may be fouling or lodged in the rotor.*
- ✓ Check frame and 3-point hitch – *ensure all components are in a safe working condition.*

After every 100 hours

- ✓ Grease PTO driveshaft – *separate telescopic drive and apply grease to internal shaft.*

Every 12 months

- ✓ Change gearbox oil

Grease Points

Lubricate the points indicated below using type LIS 3 grease.

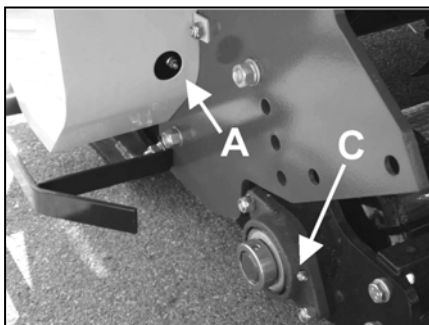

A. Rotor Shaft L/H Bearing
C. Rear Roller L/H Bearing

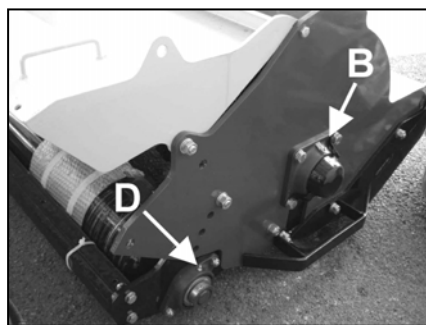

B. Rotor Shaft R/H Bearing
D. Rear Roller R/H Bearing
E. Tension Pulley Bearing ▶

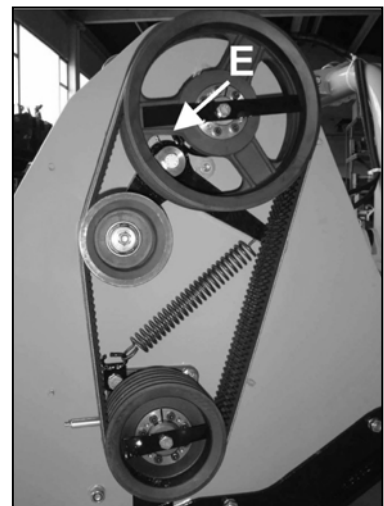

Right hand build machine illustrated

Gearbox Lubrication

The photo opposite show the lubrication access points for the gearbox and half shaft drive.

Lubricant level should be checked on a daily basis during work and topped up only if required.

Checking the level is by removal of the level plug – lubricant should be inline with the bottom of this aperture. Topping up the lubricant is performed via filler plugs to a point where the oil starts to drip out of level plug aperture. Replace and tighten the plugs before using the machine.

Gearbox oil should be replaced annually – draining the oil is via the drain plug under the gearbox as indicated in the photo above.

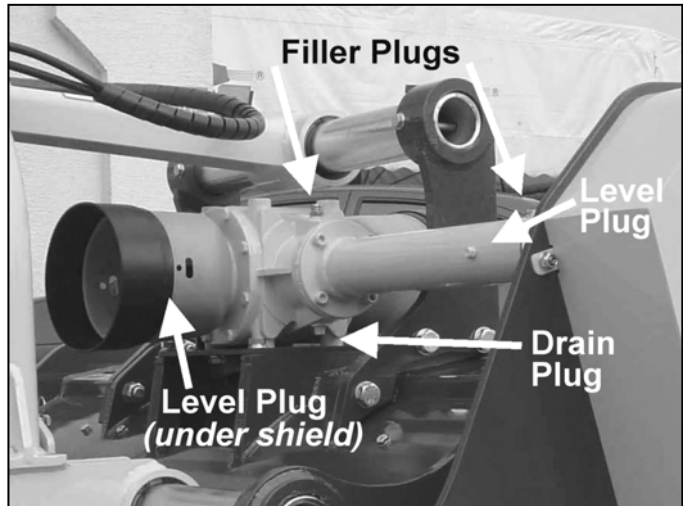

Capacities & Lubricant

4.2 Litre SAE90 – 245 & 270 models.

4.5 Litre SAE90 – 300 models.

Flail replacement

The rotor and flails should be inspected for wear or damage on a regular basis – missing, damaged or worn flails should be replaced immediately. When replacing a flail the diametrically opposite flail should also be replaced at the same time in order to maintain rotor balance.

DANGER: Machine and tractor should be switched off and the starting key removed at all times when inspecting or maintaining the machine – Never work on a machine that is switch on and running.

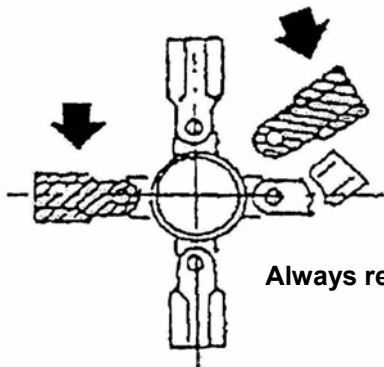

Always replace flails in opposing pairs

Rotor Vibration

If vibration of the rotor is experienced the machine should be stopped immediately – this is often a sign that a flail is either missing or severely damaged, if this is the case do not use the machine until the problem has been rectified. If vibration continues, or occurs for no apparent reason, the rotor must be checked and, if necessary, rebalanced before using the machine again. Contact your local dealer for further advice or assistance on this subject.

TROUBLESHOOTING

PROBLEM	POSSIBLE CAUSES	REMEDIES
Irregular Cut	Worn, bent or broken flails	<i>Replace flails</i>
	RPM too low	<i>Increase RPM</i>
	Machine not level to the ground	<i>Correct mounting on tractor</i>
	Clogged material caused by excessive forward speed	<i>Reduce forward speed</i>
Noise	Loose bolts	<i>Check and tighten bolts</i>
	Damaged components	<i>Repair or replace</i>
Noisy gearbox	Lack of lubrication	<i>Top up oil to correct level</i>
	Worn gears	<i>Replace worn components</i>
	Worn bearings	<i>Replace worn components</i>
Vibration	Broken, worn or missing flails	<i>Replace flails</i>
	Rotor out of balance	<i>Balance or replace rotor</i>
	Worn rotor bearings	<i>Replace rotor bearings</i>
Excessive backlash in joints	Worn pins	<i>Replace pins</i>
Tight bearings	Bearings dirty or ungreased	<i>Clean and grease</i>
	Violent lowering down of machine	<i>Lower machine gently</i>
Belts overheating	Belts slipping on pulleys	<i>Tension belts</i>
	Flails contacting the ground	<i>Raise cutting height</i>
	Working speed too high	<i>Reduce working speed</i>

Machine Disposal

Disposal of this machine and any of its component parts must be performed in a responsible and inoffensive manner respecting all current laws relating to this subject. Materials forming this machine that must undergo differentiated division and disposal are:

- Steel
- Mineral Oil
- Rubber
- Plastic



McConnel Limited, Temeside Works, Ludlow, Shropshire SY8 1JL. England.
Telephone: 01584 873131. Facsimile: 01584 876463. www.mcconnel.com