

Publication 527
January 2008
Part No. 41571.27
Revised: 20.06.17

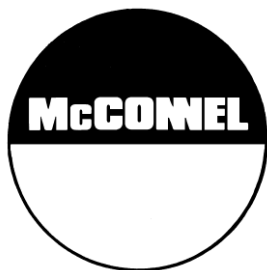

MAGNUM

EURO & EURO OPEN Models 230 / 250 / 280

Front / Rear Mounted Shredder Mowers

Operator & Parts Manual

For machines 04/09 - 03/14



IMPORTANT

VERIFICATION OF WARRANTY REGISTRATION



DEALER WARRANTY INFORMATION & REGISTRATION VERIFICATION

It is imperative that the selling dealer registers this machine with McConnel Limited before delivery to the end user – failure to do so may affect the validity of the machine warranty.

To register machines go to the McConnel Limited web site at www.mcconnel.com, log onto 'Dealer Inside' and select the 'Machine Registration button' which can be found in the Service Section of the site. Confirm to the customer that the machine has been registered in the section below.

Should you experience any problems registering a machine in this manner please contact the McConnel Service Department on 01584 875848.

Registration Verification

| |
|--|
| Dealer Name: |
| Dealer Address: |
| Customer Name: |
| Date of Warranty Registration:/...../..... Dealer Signature: |

NOTE TO CUSTOMER / OWNER

Please ensure that the above section above has been completed and signed by the selling dealer to verify that your machine has been registered with McConnel Limited.

IMPORTANT: During the initial 'bedding in' period of a new machine it is the customer's responsibility to regularly inspect all nuts, bolts and hose connections for tightness and re-tighten if required. New hydraulic connections occasionally weep small amounts of oil as the seals and joints settle in – where this occurs it can be cured by re-tightening the connection – *refer to torque settings chart below*. The tasks stated above should be performed on an hourly basis during the first day of work and at least daily thereafter as part of the machines general maintenance procedure.

TORQUE SETTINGS FOR HYDRAULIC FITTINGS

| HYDRAULIC HOSE ENDS | | |
|---------------------|---------|--------|
| BSP | Setting | Metric |
| 1/4" | 18 Nm | 19 mm |
| 3/8" | 31 Nm | 22 mm |
| 1/2" | 49 Nm | 27 mm |
| 5/8" | 60 Nm | 30 mm |
| 3/4" | 80 Nm | 32 mm |
| 1" | 125 Nm | 41 mm |
| 1.1/4" | 190 Nm | 50 mm |
| 1.1/2" | 250 Nm | 55 mm |
| 2" | 420 Nm | 70 mm |

| PORT ADAPTORS WITH BONDED SEALS | | |
|---------------------------------|---------|--------|
| BSP | Setting | Metric |
| 1/4" | 34 Nm | 19 mm |
| 3/8" | 47 Nm | 22 mm |
| 1/2" | 102 Nm | 27 mm |
| 5/8" | 122 Nm | 30 mm |
| 3/4" | 149 Nm | 32 mm |
| 1" | 203 Nm | 41 mm |
| 1.1/4" | 305 Nm | 50 mm |
| 1.1/2" | 305 Nm | 55 mm |
| 2" | 400 Nm | 70 mm |

WARRANTY POLICY

WARRANTY REGISTRATION

All machines must be registered, by the selling dealer with McConnel Ltd, before delivery to the end user. On receipt of the goods it is the buyer's responsibility to check that the Verification of Warranty Registration in the Operator's Manual has been completed by the selling dealer.

1. LIMITED WARRANTIES

- 1.01. *All machines supplied by McConnel Ltd are warranted to be free from defects in material and workmanship from the date of sale to the original purchaser for a period of 12 months, unless a different period is specified.*
- 1.02. *All spare parts supplied by McConnel Ltd and purchased by the end user are warranted to be free from defects in material and workmanship from the date of sale to the original purchaser for a period of 6 months. All parts warranty claims must be supported by a copy of the failed part invoice to the end user. We cannot consider claims for which sales invoices are not available.*
- 1.03. *The warranty offered by McConnel Ltd is limited to the making good by repair or replacement for the purchaser any part or parts found, upon examination at its factory, to be defective under normal use and service due to defects in material or workmanship. Returned parts must be complete and unexamined. Pack the component(s) carefully so that any transit damage is avoided. All ports on hydraulic items should be drained of oil and securely plugged to prevent seepage and foreign body ingress. Certain other components, electrical items for example, may require particular care when packing to avoid damage in transit.*
- 1.04. *This warranty does not extend to any product from which McConnel Ltd's serial number plate has been removed or altered.*
- 1.05. *This warranty does not apply to any part of the goods, which has been subjected to improper or abnormal use, negligence, alteration, modification, fitment of non-genuine parts, accident damage, or damage resulting from contact with overhead power lines, damage caused by foreign objects (e.g. stones, iron, material other than vegetation), failure due to lack of maintenance, use of incorrect oil or lubricants, contamination of the oil, or which has served its normal life. This warranty does not apply to any expendable items such as blades, belts, clutch linings, filter elements, flails, flap kits, skids, soil engaging parts, shields, guards, wear pads, pneumatic tyres or tracks.*
- 1.06. *Temporary repairs and consequential loss - i.e. oil, downtime and associated parts are specifically excluded from the warranty.*
- 1.07. *Warranty on hoses is limited to 12 months and does not include hoses which have suffered external damage. Only complete hoses may be returned under warranty, any which have been cut or repaired will be rejected.*
- 1.08. *Machines must be repaired immediately a problem arises. Continued use of the machine after a problem has occurred can result in further component failures, for which McConnel Ltd cannot be held liable, and may have safety implications.*
- 1.09. *If in exceptional circumstances a non McConnel Ltd part is used to effect a repair, warranty reimbursement will be at no more than McConnel Ltd's standard dealer cost for the genuine part.*
- 1.10. *Except as provided herein, no employee, agent, dealer or other person is authorised to give any warranties of any nature on behalf of McConnel Ltd.*
- 1.11. *For machine warranty periods in excess of 12 months the following additional exclusions shall apply:*
 - 1.11.1. *Hoses, exposed pipes and hydraulic tank breathers.*
 - 1.11.2. *Filters.*
 - 1.11.3. *Rubber mountings.*
 - 1.11.4. *External electric wiring.*
 - 1.11.5. *Bearings and seals.*

- 1.12. *All service work, particularly filter changes, must be carried out in accordance with the manufacturer's service schedule. Failure to comply will invalidate the warranty. In the event of a claim, proof of the service work being carried out may be required.*
- 1.13. *Repeat or additional repairs resulting from incorrect diagnosis or poor quality previous repair work are excluded from warranty.*

NB Warranty cover will be invalid if any non-genuine parts have been fitted or used. Use of non-genuine parts may seriously affect the machine's performance and safety. McConnel Ltd cannot be held responsible for any failures or safety implications that arise due to the use of non-genuine parts.

2. REMEDIES AND PROCEDURES

- 2.01. *The warranty is not effective unless the Selling Dealer registers the machine, via the McConnel Ltd web site and confirms the registration to the purchaser by completing the confirmation form in the operator's manual.*
- 2.02. *Any fault must be reported to an authorised McConnel Ltd dealer as soon as it occurs. Continued use of a machine, after a fault has occurred, can result in further component failure for which McConnel Ltd cannot be held liable.*
- 2.03. *Repairs should be undertaken within two days of the failure. Claims submitted for repairs undertaken more than 2 weeks after a failure has occurred, or 2 days after the parts were supplied will be rejected, unless the delay has been authorised by McConnel Ltd. Please note that failure by the customer to release the machine for repair will not be accepted as a reason for delay in repair or submitting warranty claims.*
- 2.04. *All claims must be submitted, by an authorised McConnel Ltd Service Dealer, within 30 days of the date of repair.*
- 2.05. *Following examination of the claim and parts, McConnel Ltd will pay, at their discretion, for any valid claim the invoiced cost of any parts supplied by McConnel Ltd and appropriate labour and mileage allowances if applicable.*
- 2.06. *The submission of a claim is not a guarantee of payment.*
- 2.07. *Any decision reached by McConnel Ltd is final.*

3. LIMITATION OF LIABILITY

- 3.01. *McConnel Ltd disclaims any express (except as set forth herein) and implied warranties with respect to the goods including, but not limited to, merchantability and fitness for a particular purpose.*
- 3.02. *McConnel Ltd makes no warranty as to the design, capability, capacity or suitability for use of the goods.*
- 3.03. *Except as provided herein, McConnel Ltd shall have no liability or responsibility to the purchaser or any other person or entity with respect to any liability, loss, or damage caused or alleged to be caused directly or indirectly by the goods including, but not limited to, any indirect, special, consequential, or incidental damages resulting from the use or operation of the goods or any breach of this warranty. Notwithstanding the above limitations and warranties, the manufacturer's liability hereunder for damages incurred by the purchaser or others shall not exceed the price of the goods.*
- 3.04. *No action arising out of any claimed breach of this warranty or transactions under this warranty may be brought more than one (1) year after the cause of the action has occurred.*

4. MISCELLANEOUS

- 4.01. *McConnel Ltd may waive compliance with any of the terms of this limited warranty, but no waiver of any terms shall be deemed to be a waiver of any other term.*
- 4.02. *If any provision of this limited warranty shall violate any applicable law and is held to be unenforceable, then the invalidity of such provision shall not invalidate any other provisions herein.*
- 4.03. *Applicable law may provide rights and benefits to the purchaser in addition to those provided herein.*



DECLARATION OF CONFORMITY

Conforming to EU Machinery Directive 2006/42/EC

We,

McCONNEL LIMITED, Temeside Works, Ludlow, Shropshire SY8 1JL, UK

Hereby declare that:

The Product; Tractor Mounted Flail Mower

Product Code; MU23, MU25, MU28

Serial No. & Date Type

Manufactured in; Slovenija

Complies with the required provisions of the Machinery Directive 2006/42/EC
The machinery directive is supported by the following harmonized standards;

- BS EN ISO 14121-1 (2007) Safety of machinery - Risk assessment, Part 1: Principles Part 2: practical guide and examples of methods.
- BS EN ISO 12100-1 (2010) Safety of machinery - Part 1: Basic terminology and methodology Part 2: Technical principles.
- BS EN 349(1993)+ A1 (2008) Safety of machinery - Minimum distances to avoid the entrapment with human body parts.
- BS EN 953 (1998) Safety of machinery - Guards General requirements for the design and construction of fixed and movable guards.
- BS EN 982(1996)+ A1 (2008) Safety requirements for fluid power systems and their components. Hydraulics

McCONNEL LIMITED operates an ISO 9001:2008 quality management system, certificate number: FM25970.

This system is continually assessed by the;
British Standards Institution (BSI), Beech House, Milton Keynes, MK14 6ES, UK
BSI is accredited by UK Accreditation Service, accreditation number: UKAS 003.
The EC declaration only applies if the machine stated above is used in accordance with the operating instructions.

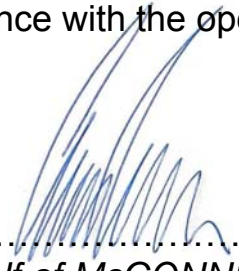
Signed *Responsible Person*
on behalf of McCONNEL LIMITED

Status: General Manager

Date: May 2011

FLAIL MOWER INSPECTION AND MAINTENANCE

A daily equipment inspection of the tractor and mower should be conducted before the equipment is used. You may use the inspection sheets to assist with these daily inspections. Any damaged or missing guards should be repaired or replaced before operating the mower. Failure to repair the damaged shield can result in objects being thrown from the mower and possibly hitting the operator or bystander.

Inspect the Mower for Safe Operating Condition

- Make sure the driveline guards and shielding are in place and in good repair.
- Inspect the chain guards, flexible and/or solid deflector thrown object shielding to assure that they are in place on the front and rear of the mower deck and in good repair. Repair or replace any damaged or missing thrown object shields.
- Ensure the mower cutting height is set high enough to reduce the possibility of the mower blades contacting the ground. Actual height will be dependent on the ground conditions. Increase the height when working in rough or undulating conditions.
- Inspect for broken, chipped, bent, missing, or severely worn blades. Replace damaged blades before operating the mower. Ensure the blade retaining bolts and fasteners are secure and tight.
- Lubricate the driveline universal joints and telescoping members daily.
- Inspect the wheel lug bolt/nuts to assure that they are tight.
- If mower is equipped with pneumatic tires, make sure they have the required air pressure.
- Inspect for worn or damaged decals and safety instructions. Replace unreadable, damaged or missing safety decals.
- Follow the operator's manual(s) inspection and maintenance instructions for lubricating parts, and keeping thrown object shielding, driveline guards, rotating parts shields, mower blades and decals in good repair.

Inspect the Tractor for Safe Operating Condition:

- Inspect the controls, lights, SMVs (Slow Moving Vehicle sign), seat belts, and ROPS to assure that they are in place and in good working order.
- Be sure the tires, wheels, lug bolts/nuts are in good condition.
- Make sure the tractor brakes and steering are in proper operating condition.
- Follow the operator's manual(s) inspection and maintenance procedures for keeping the tractor in good and safe condition before operating.

The inspection sheet on the following page should be kept in this book as a record. A second sheet is included for you to cut out and photocopy or the inspection sheets can be downloaded from our website at;

<http://www.mcconnel.com/support/aftersales/default.aspx?nav=After Sales>



FLAIL MOWERS PRE-OPERATION Inspection

Mower ID _____ Date: _____ Shift: _____

WARNING



Before conducting the inspection, make sure the tractor engine is off, with the key removed, all rotation has stopped and the tractor is in park with the parking brake engaged. Make sure the mower is resting on the ground or is securely blocked up and supported and all hydraulic pressure has been relieved.

| Item | Condition at start of shift | Specific Comments if not O.K. |
|--|-----------------------------|-------------------------------|
| The Operator's Manual is in the Canister on the mower | | |
| All Warning Decals are in place, clean and legible | | |
| The Hyd. Cylinder pins are tight and correctly secured | | |
| The Hyd Cylinder hose connections are tight | | |
| There are no oil leaks | | |
| There are no damaged hoses | | |
| Flails are not missing chipped, broken or excessively worn | | |
| The Flail bolts are tight | | |
| The Front & Rear Flaps are fitted and in good condition | | |
| The Skid shoes are in good condition & tight | | |
| The Rotor Bearings are in good condition and greased | | |
| The Roller bearings are in good condition and greased | | |
| There are no cracks or holes in flail casing | | |
| The drive line/gearbox shaft guard is in good condition | | |
| The drive line/gearbox shaft guard is correctly secured | | |
| Driveline telescoping members & u-joints are lubricated | | |
| Driveline yokes are securely attached to tractor & mower | | |
| All linkage mounting pins are securely fastened | | |
| | | |
| | | |

Operators Signature: _____

DO NOT OPERATE an UNSAFE TRACTOR or MOWER



TRACTOR PRE-OPERATION Inspection

Power Arm ID _____ Date: _____ Shift: _____

WARNING



Before conducting the inspection, make sure the tractor engine is off, the key is removed all rotation has stopped and the tractor is in park with the parking brake engaged. Any implement attached to the tractor is firmly on the ground.

| Item | Condition at start of shift | Specific Comments if not O.K. |
|--|-----------------------------|-------------------------------|
| The flashing lights function properly. | | |
| All lights are clean and working correctly | | |
| All cab windows are clean and wipers working correctly | | |
| The SMV sign, where required, is clean and visible. | | |
| The tyres are in good condition with correct pressure. | | |
| The wheel nuts are tight. | | |
| The tractor brakes are in good condition. | | |
| The steering linkage is in good condition. | | |
| There are no visible oil leaks. | | |
| The hydraulic controls function properly. | | |
| The ROPS or ROPS cab is in good condition. | | |
| The seatbelt is in place and in good condition. | | |
| The 3-point hitch is in good condition. | | |
| The drawbar/pick up hook is secure & in good condition | | |
| The PTO master shield is in place. | | |
| The engine oil level is full. | | |
| The brake fluid level is full. | | |
| The power steering fluid level is full. | | |
| The fuel level is adequate. | | |
| The engine coolant fluid level is full. | | |
| The radiator & oil cooler are free of debris. | | |
| The air filter is in good condition | | |
| | | |
| | | |

Operators Signature: _____

DO NOT OPERATE an UNSAFE TRACTOR or MOWER



FLAIL MOWERS PRE-OPERATION Inspection

Mower ID _____ Date: _____ Shift: _____

WARNING



Before conducting the inspection, make sure the tractor engine is off, with the key removed, all rotation has stopped and the tractor is in park with the parking brake engaged. Make sure the mower is resting on the ground or is securely blocked up and supported and all hydraulic pressure has been relieved.

| Item | Condition at start of shift | Specific Comments if not O.K. |
|--|-----------------------------|-------------------------------|
| The Operator's Manual is in the Canister on the mower | | |
| All Warning Decals are in place, clean and legible | | |
| The Hyd. Cylinder pins are tight and correctly secured | | |
| The Hyd Cylinder hose connections are tight | | |
| There are no oil leaks | | |
| There are no damaged hoses | | |
| Flails are not missing chipped, broken or excessively worn | | |
| The Flail bolts are tight | | |
| The Front & Rear Flaps are fitted and in good condition | | |
| The Skid shoes are in good condition & tight | | |
| The Rotor Bearings are in good condition and greased | | |
| The Roller bearings are in good condition and greased | | |
| There are no cracks or holes in flail casing | | |
| The drive line/gearbox shaft guard is in good condition | | |
| The drive line/gearbox shaft guard is correctly secured | | |
| Driveline telescoping members & u-joints are lubricated | | |
| Driveline yokes are securely attached to tractor & mower | | |
| All linkage mounting pins are securely fastened | | |
| | | |
| | | |

Operators Signature: _____

DO NOT OPERATE an UNSAFE TRACTOR or MOWER



TRACTOR PRE-OPERATION Inspection

Power Arm ID _____ Date: _____ Shift: _____

WARNING



Before conducting the inspection, make sure the tractor engine is off, the key is removed all rotation has stopped and the tractor is in park with the parking brake engaged. Any implement attached to the tractor is firmly on the ground.

| Item | Condition at start of shift | Specific Comments if not O.K. |
|--|-----------------------------|-------------------------------|
| The flashing lights function properly. | | |
| All lights are clean and working correctly | | |
| All cab windows are clean and wipers working correctly | | |
| The SMV sign, where required, is clean and visible. | | |
| The tyres are in good condition with correct pressure. | | |
| The wheel nuts are tight. | | |
| The tractor brakes are in good condition. | | |
| The steering linkage is in good condition. | | |
| There are no visible oil leaks. | | |
| The hydraulic controls function properly. | | |
| The ROPS or ROPS cab is in good condition. | | |
| The seatbelt is in place and in good condition. | | |
| The 3-point hitch is in good condition. | | |
| The drawbar/pick up hook is secure & in good condition | | |
| The PTO master shield is in place. | | |
| The engine oil level is full. | | |
| The brake fluid level is full. | | |
| The power steering fluid level is full. | | |
| The fuel level is adequate. | | |
| The engine coolant fluid level is full. | | |
| The radiator & oil cooler are free of debris. | | |
| The air filter is in good condition | | |
| | | |
| | | |

Operators Signature: _____

DO NOT OPERATE an UNSAFE TRACTOR or MOWER

LIST OF CONTENTS

OPERATOR SECTION

| | |
|--------------------------------------|----|
| General Information | 1 |
| Machine Description & Purpose of Use | 2 |
| Machine Identification | 2 |
| Technical Data | 2 |
| Technical Specifications | 3 |
| Safety Information | 4 |
| Safety Decals | 5 |
| Vehicle / Tractor Preparation | 6 |
| Machine Attachment | 7 |
| PTO Shaft | 8 |
| Pre-Operational Checks | 8 |
| Setting Up and Adjustment | 9 |
| Drive Belts | 10 |
| Operation | 11 |
| Detachment and Storage | 12 |
| Maintenance | 13 |
| Troubleshooting | 15 |

PARTS SECTION

| | |
|---------------------------|----|
| Magnum Euro Assembly | 18 |
| Magnum Euro Open Assembly | 24 |
| Support Wheels Option | 30 |
| Decal Kit – 230 Models | 32 |
| Decal Kit – 250 Models | 33 |
| Decal Kit – 280 Models | 34 |

GENERAL INFORMATION

Always read this manual before fitting or operating the machine – whenever any doubt exists contact your dealer or the McConnel Service Department for advice and assistance.

Use only McConnel Genuine Service Parts on McConnel Equipment and Machines

DEFINITIONS – The following definitions apply throughout this manual:

WARNING

An operating procedure, technique etc., which –
can result in personal injury or loss of life if not observed carefully.

CAUTION

An operating procedure, technique etc., which –
can result in damage to either machine or equipment if not observed carefully.

NOTE

An operating procedure, technique etc., which –
is considered essential to emphasis.

LEFT AND RIGHT HAND

This term is applicable to the machine when attached to the tractor and is viewed
from the rear – this also applies to tractor references.

MACHINE & DEALER INFORMATION

Record the Serial Number of your machine on this page and always quote this number when ordering parts. Whenever information concerning the machine is requested remember also to state the make and model of tractor to which the machine is fitted.

| | |
|-------------------------------|---------------------------|
| Machine Serial Number: | Installation Date: |
| Machine Model details: | |
| Dealer Name: | |
| Dealer Address: | |
| Dealer Telephone No: | |
| Dealer Email Address: | |

MACHINE DESCRIPTION & PURPOSE OF USE

The Magnum Euro series of machines are '3-point linkage' tractor mounted universal flail mower/shredders designed primarily for the mulching of grasses, brambles, small bushes, branches, vines, and general crop residues. Their tough construction, working widths of 2.3, 2.5 or 2.8m and offset capability of up to 0.5m makes them ideal for maintenance use in all green areas, vineyards, orchards, on verges and in scrubland by farmers and contractors alike. Open models feature an opening rear cover that allows for quicker discharge of materials when working in denser vegetation.

These machines should only be used to perform tasks for which they were designed – use of the machine for any other function may be both dangerous to persons and damaging to components and is therefore not advisable.

MACHINE IDENTIFICATION

Each machine is fitted with an identification plate with the following information:

1. Machine (Part Number)
2. Machine Serial No.
3. Machine Weight

When ordering spares or replacement parts from your local dealer it is important to quote both Part Number and Serial Number as stated on the identification plate so the machine and model can be quickly and correctly identified.



Machine Identification Plate

TECHNICAL DATA

COMPONENT IDENTIFICATION

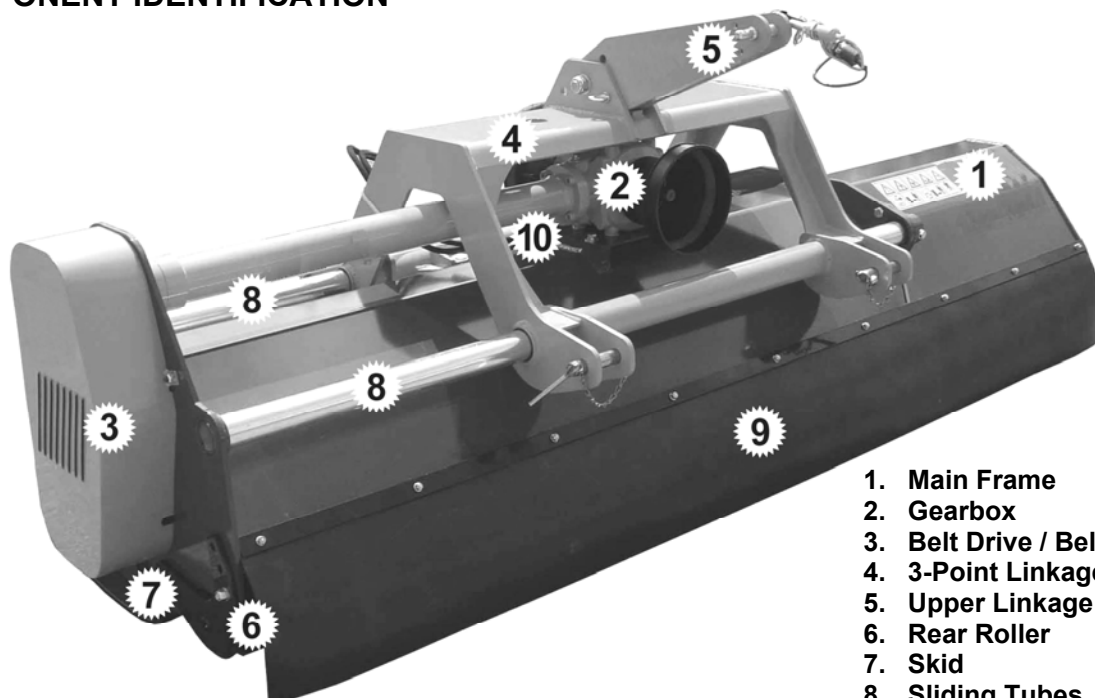

1. Main Frame
2. Gearbox
3. Belt Drive / Belt Guard
4. 3-Point Linkage
5. Upper Linkage
6. Rear Roller
7. Skid
8. Sliding Tubes
9. Rubber Guard
10. Hydraulic Ram

TECHNICAL SPECIFICATIONS

Euro Models

| SPECIFICATION | 230 | 250 | 280 |
|---------------------------|-------------------|-------------------|-------------------|
| Working Width | 2280mm | 2440mm | 2770mm |
| Tractor Power Requirement | 55-60 HP | 65-75 HP | 75-85 HP |
| PTO RPM | 1000 RPM | 1000 RPM | 1000 RPM |
| Rotor Shaft RPM | 2243 RPM | 2243 RPM | 2243 RPM |
| Hammer Blades | 26 | 28 | 32 |
| Y-Blades | 78 | 84 | 96 |
| Machine Weight | 750kg | 785kg | 850kg |
| Offset Capability | 500mm | 500mm | 500mm |
| Linkage Type | 3-Point (Cat. II) | 3-Point (Cat. II) | 3-Point (Cat. II) |
| Machine Width | 2510mm | 2670mm | 3000mm |
| Machine Length | 1010mm | 1010mm | 1010mm |
| Machine Height | 1050mm | 1050mm | 1050mm |

Euro Open Models

| SPECIFICATION | 230 | 250 | 280 |
|---------------------------|-------------------|-------------------|-------------------|
| Working Width | 2280mm | 2440mm | 2770mm |
| Tractor Power Requirement | 55-60 HP | 65-75 HP | 75-85 HP |
| PTO RPM | 1000 RPM | 1000 RPM | 1000 RPM |
| Rotor Shaft RPM | 2243 RPM | 2243 RPM | 2243 RPM |
| Hammer Blades | 26 | 28 | 32 |
| Y-Blades | 78 | 84 | 96 |
| Machine Weight | 780kg | 815kg | 865kg |
| Offset Capability | 500mm | 500mm | 500mm |
| Linkage Type | 3-Point (Cat. II) | 3-Point (Cat. II) | 3-Point (Cat. II) |
| Machine Width | 2510mm | 2670mm | 3000mm |
| Machine Length | 1010mm | 1010mm | 1010mm |
| Machine Height | 1050mm | 1050mm | 1050mm |

OPTIONAL EQUIPMENT

The standard flails fitted to the machine are the hammer blade type, Y-blade flails are optional. The cutting capability of the each particular type of flail will be dependant on the sort and hardness of the material being cut, but in general the following cutting thicknesses apply:

Y-blade flails – for materials up to a maximum of 30mm diameter.

Hammer flails – for materials up to a maximum of 50mm diameter.

NOISE LEVEL

The sound level of this machine, as measured at the operator's ear, is within the range of 70 to 90 dB when the rear window of the tractor is open. We recommend that ear protectors are worn and the tractor windows kept closed at all times when operating this machine.

SAFETY INFORMATION

General safety rules:

- ▲ Always read and follow the instructions for the use and maintenance of the machine before carrying out any work operations or servicing tasks.
- ▲ Improper use of the machine is both highly dangerous to persons and damaging to the machine components – only use the machine for its designated task.
- ▲ Both operators and the maintenance fitters should be familiar with the machine and fully aware of dangers surrounding improper use or incorrect repairs.
- ▲ Before starting, checks to both tractor and machine must be carried out as regards: functionality, road safety, accident prevention rules.
- ▲ Even when using the machine correctly, stones or other objects may be thrown a long distance. Therefore nobody must stand within the danger area. Special attention must be paid when working near roads or buildings.
- ▲ Use tractor's fitted with safety cabs.
- ▲ The condition of flails and of machine guards must be checked before beginning the daily work - they must be replaced if damaged or missing before you use the machine.
- ▲ During checks or repairs, make sure nobody could start the machine by mistake.
- ▲ Never wear loose or fluttering clothes.
- ▲ Never carry passengers on the tractor.
- ▲ Never carry passengers on the machine.
- ▲ Never connect the power takeoff with the engine running.
- ▲ Never approach the machine until the rotor has completely stopped.
- ▲ Do not enter the working zone of the PTO shaft. It is dangerous to approach the rotating parts of a machine.
- ▲ Keep the PTO shaft guard in good condition.
- ▲ Before starting, check the surrounding area for the likely presence of children and/or animals.
- ▲ Do not stand near the machine when it is operating.
- ▲ The PTO shaft must be assembled and disassembled only with the engine stopped and the starting key removed.
- ▲ Before connecting the power takeoff, check that the speed and the rotational direction correspond to those of the machine.
- ▲ Immediately replace missing or damaged safety decals.
- ▲ Before leaving the tractor with the machine attached, proceed as follows:
 1. Disconnect the power takeoff,
 2. Put the machine steadily on the ground using the tractor's hydraulic lift.
 3. Apply the hand brake and, if the ground is steeply sloping, wedge the tractor.
 4. Remove the starting key.

Transportation Safety

- ▲ In transport, reduce speed, especially on bumpy roads, the weight of the machine may render driving difficult and damage the machine itself.
- ▲ Ensure the levers that operate the hydraulic lift are locked, to avoid the lowering of the machine during transport.
- ▲ When driving on public roads, respect all road rules in force.
- ▲ Never transport the machine with the rotor running, even for short distances.

Operating Safety

- ▲ Pay special attention when working with the machine not to touch fixed objects such as road drain, walls, shafts, kerbs, guard rails, tracks etc. This could cause the breakage of the flails, which would be thrown out of the machine at very high speed.
- ▲ If wires, ropes or chains should become entangled in the rotor stop immediately to prevent damage or dangerous situations; stop the rotor and the tractor, take out the starting key. Put working gloves on; clear the rotor with the aid of pliers or shears. Do not try to disentangle by inverting the rotational direction of the rotor.
- ▲ Do not use the machine when excessive vibration is experienced, as this may cause breakage and serious damage - find the cause of the vibration and eliminate it before using the machine again.

Although the information given here covers a wide range of safety subjects, it is impossible to predict every eventuality that can occur under differing circumstances whilst operating this machine. No advice given here can replace 'good common sense' and 'total awareness' at all times, but will go a long way towards the safe use of your McConnel machine.

SAFETY DECALS

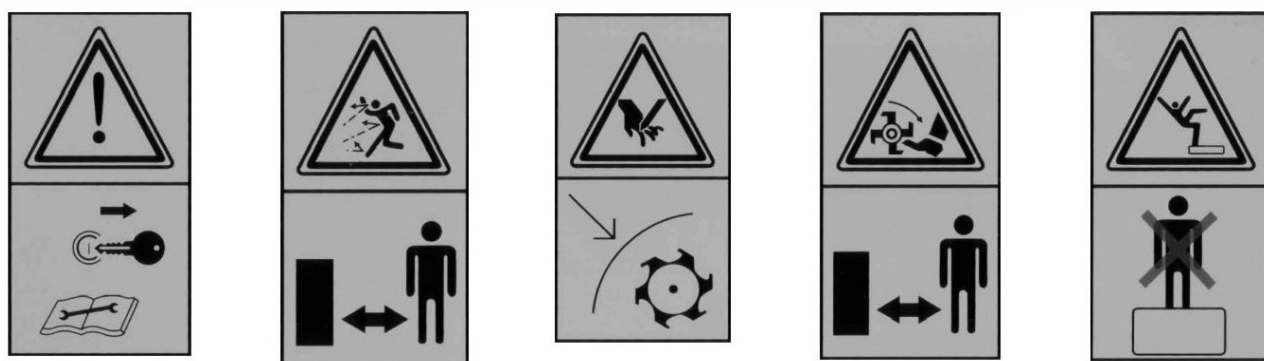

1.

2.

3.

4.

5.

1. Always switch machine off, remove starting key and read instruction manual before performing service or maintenance work on the machine.
2. Keep a safe distance from the machine at all times - risk from projection of objects.
3. Risk of hand injury – always ensure all guard are fitted and in place when machine is operating.
4. Risk of feet injury – keep at a safe distance from the machine when it is operating.
5. Never stand or ride on the machine.

VEHICLE / TRACTOR PREPARATION

We recommend vehicles are fitted with cabs using 'safety glass' windows and protective guarding when used with our machines.

Fit Operator Guard (part no. 73 13 324) using the hooks provided. Shape the mesh to cover all vulnerable areas.

Remember the driver must be looking through mesh and/or polycarbonate glazing when viewing the machine in all positions - unless the vehicle/ cab manufacturer can demonstrate that the penetration resistance is equivalent to, or higher than, that provided by mesh/polycarbonate glazing. If the tractor has a roll bar only, a frame must be made to carry both mesh and polycarbonate glazing. The operator should also use personal protective equipment to reduce the risk of serious injury such as; eye protection (mesh visor to EN1731 or safety glasses to EN166), hearing protection to EN352, safety helmet to EN297, gloves, filter mask and high visibility clothing.

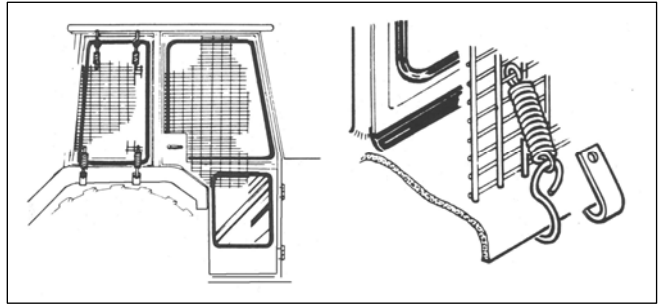

Vehicle Ballast

It is imperative when attaching 'third-party' equipment to a vehicle that the maximum possible stability of the machine and vehicle combination is achieved – this can be accomplished by the utilisation of 'ballast' in order to counter-balance the additional equipment added.

Front weights may be required for rear mounted machines to place 15% of total outfit weight on the front axle for stable transport on the road and to reduce 'crabbing' due to the drag of the cutting unit when working on the ground.

Where a machine works to the side of the tractor rear weights may be required to maintain a reasonable amount of rear axle load on the opposing wheel.

All factors must be addressed in order to match the type and nature of the equipment added to the circumstances under which it will be used - factors that effect stability are:

- Centre of gravity of the tractor/machine combination.
- Geometric conditions, e.g. position of the cutting head and ballast.
- Weight, track width and wheelbase of the tractor.
- Acceleration, braking, turning and the relative position of the cutting unit during these operations.
- Ground conditions, e.g. slope, grip, load capability of the soil/surface.
- Rigidity of implement mounting.

Suggestions to increase stability:

- Increasing rear wheel track - *a vehicle with a wider wheel track is more stable.*
- Ballasting the wheel; it is preferable to use external weights but liquid can be added to around 75% of the tyre volume – water with anti-freeze or the heavier Calcium Chloride alternative can be used.
- Addition of weights – care should be taken in selecting the location of the weights to ensure they are added to a position that offers the greatest advantage.
- Front axle locking, check with tractor manufacturer.

The advice above is offered as a guide for stability only and is not a guide to vehicle strength. It is therefore recommended that you consult your vehicle manufacturer or local dealer to obtain specific advice on this subject, additionally advice should be sought from a tyre specialist with regard to tyre pressures and ratings suitable for the type and nature of the machine you intend to fit.

ATTACHING THE MACHINE TO THE TRACTOR

Attachment of the machine to the tractor should always be performed on a firm level site.

Upper Linkage Position

The upper linkage of the machine has two working modes to allow the machine to be mounted and operated either on the front of the tractor or on the rear:

1. Front Mounted Linkage Position
2. Rear Mounted Linkage Position

To swap the linkage position, remove the position locking pin and swing the linkage over to the opposing side of the machine, replace the position locking pin and secure in place with a locking clip

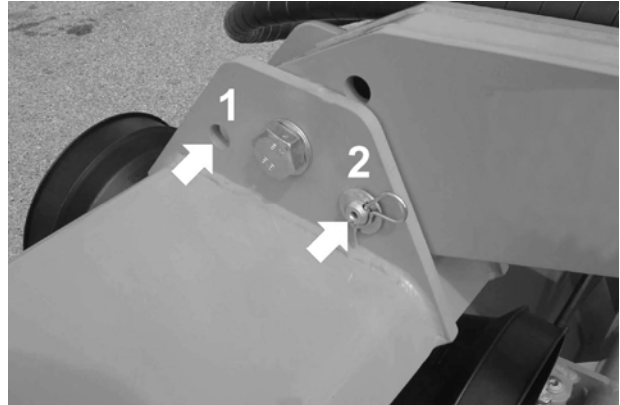

NOTE: The position locking pin must always be in position during attachment and transportation of the machine but can be removed during work for a floating position. Always remember to replace the pin before re-transporting the machine.

Linkage Points

- A – Lower Attachment Points (Linkage Arms)
- B – Upper Attachment Point (Top Link)

Attachment to Tractor

Determine if the machine is to be front mounted or rear mounted and set the upper linkage into the required position as described above.

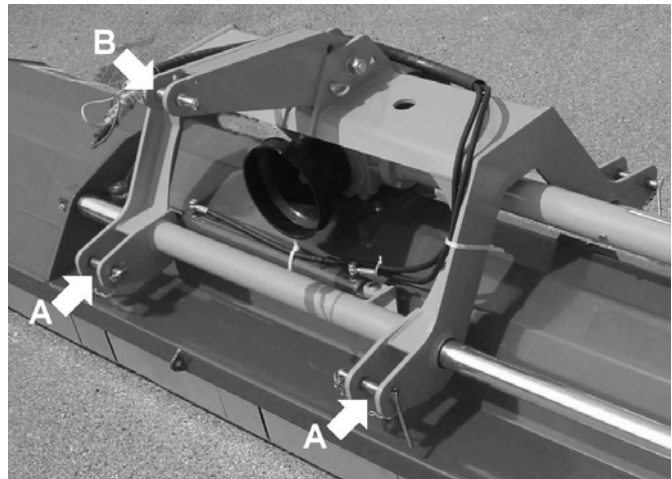

Position the tractor's lower linkage at the same height as the machines lower attachment points – indicated 'A' in the diagram above.

Remove the machine lower linkage pins from location 'A'.

Carefully manoeuvre the tractor squarely to the machine and into its position within the attachment points – fine adjustment of the tractor lower linkage height may be necessary to correctly position the linkage and permit refitting of the linkage pins.

Insert linkage pins at location 'A' and secure in position with locking clips.

Fit top link to upper attachment point 'B'.

Raise the machine on the tractors hydraulics and adjust top link so that the machine is parallel to the ground.

Fit and adjust check chains and/or stabiliser bars to lock the machine into a central position on the tractor.

Connect hydraulics.

Fit PTO Shaft and attach torque chains to a suitable location – refer to following page for details of PTO measurement and shaft length adjustment.

PTO Shaft Measurement

Measure the PTO shaft and cut to the dimension shown – the finished length of the PTO shaft should be 75mm (3”) less than the measured distance ‘A’ - between tractor shaft and gearbox stub shaft - to enable fitting.

NOTE:

For subsequent use with different tractors measure again, there must be a minimum shaft overlap of 150mm (6”).

Fit PTO in position and attach the torque chains to a convenient location to prevent the shaft guards from rotating.

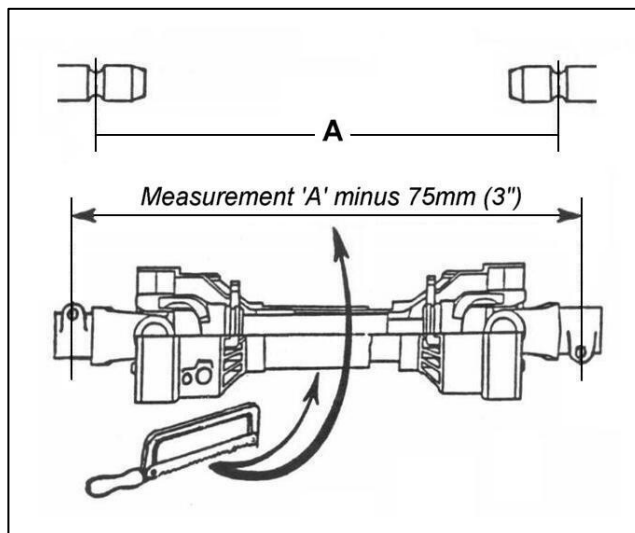

PTO Shaft Length Adjustment

1. Shorten outer plastic tube to 40mm less than the shortest envisaged shaft length.
2. Remove the marked tube.
3. Remove same length from inner plastic tube and metal shaft profiles (inner and outer).
4. De-burr all edges and remove ‘swarf’ to ensure smooth operation.

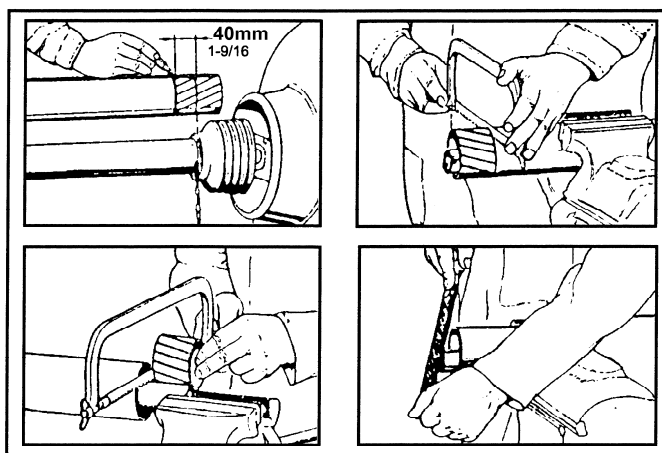

Pre-Operational Checks

Before commencing work with the machine the following checks should be performed:

- Make a visual inspection of the machine to ensure it is in good operational condition.
- Check all safety guarding is in position and in full working order.
- Check rotor for missing or damaged flails and replace if required.
- Check all greasing points are well lubricated.
- Check gearbox oil level.
- Check belt tension and adjust if required.
- Check PTO speed and direction match that of the machine.

SETTING UP AND ADJUSTMENT

The height of cut is dependent on working conditions and volume of material. The cutting height can be regulated with the hydraulic system on the tractor and/or rear roller adjustment. The minimum height of cut should be between 1 – 3cm.

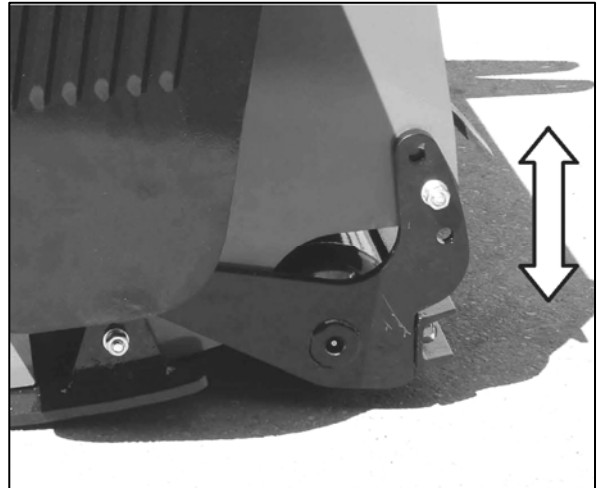

NOTE: The machine must always run on the rear roller not the side skids – side skids are a protection feature and in normal working conditions remain clear of the ground. Do not allow the rotor flails to contact the ground - set roller height to allow a minimum flail to ground clearance of 1 to 3cm.

Offsetting

The machine features a hydraulically operated offsetting capability of up to 500mm allowing the machine to cut larger areas of material beyond the wheel tracks of the tractor – this is particularly useful for verge mowing duties and work in areas of limited or restricted accessibility.

The machine offsets to the right hand side of the tractor.

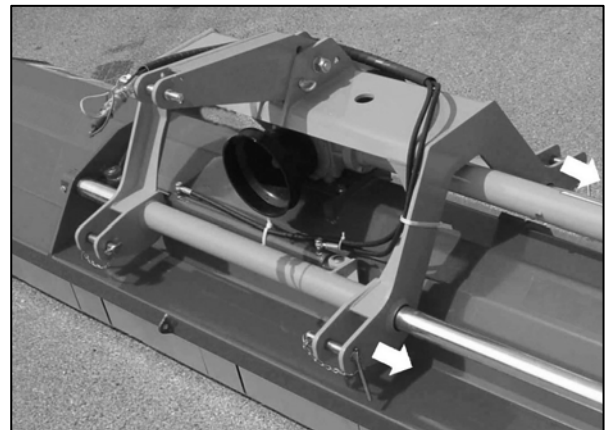

Hydraulically operated offset of up to 500mm

DRIVE BELTS

Power from the tractor via the machines gearbox and half-shaft is transferred to the rotor through sets of belts - *the Euro 230 models employ a 4 belt system and Euro 250 & 280 models employ a 5 belt system.* Correct tensioning of the belts is required for both optimal operation of the machine and long lasting belt life – in order to ensure correct belt tension the machines are fitted with automatic belt tensioning.

Check tightness of the taper lock bolts on a regular basis, the torque setting is 45Nm.

Belt Tensioner

Machines are fitted as standard with an automatic belt tensioning system. The system consists of a pre-tensioned arm and strain pulley set at 22° that permanently runs on the belts exerting sufficient pressure to keep the belts correctly tensioned.

For correct tension the system must be set at an angle of 22° – an arrow is marked on the tension device to aid its setting, which should always be performed when the belts are cold.

No other adjustment or maintenance will be required on the belt tensioning system other than routine inspection and general cleaning of components when inspecting belt wear.

WARNING: Checking of belts and drive components should only be carried out with tractors engine switched off, starting key removed and the PTO shaft disconnected. Never attempt to run the machine with the belt guard removed.

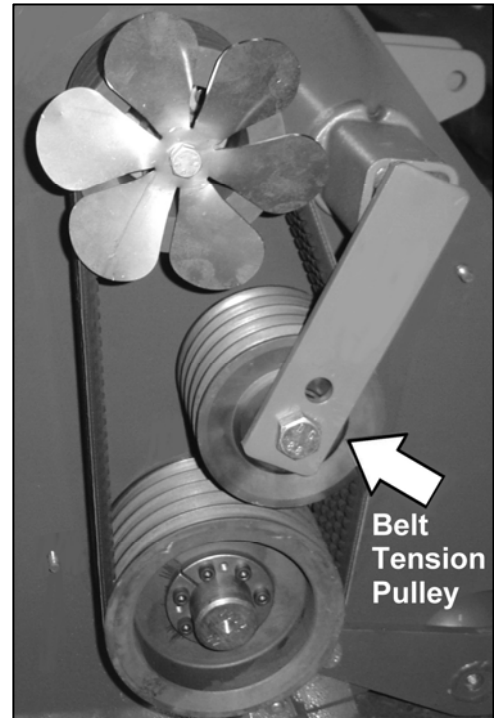

Belt Tensioner ►

Machine RPM

These machines are all 1000 RPM - before operating the machine always ensure the RPM is compatible with the tractor PTO speed – this is particularly important on tractors that have different PTO speeds front and rear.

WARNING: Always check machine and tractor PTO speeds are compatible before using the machine.

Flail Types

Two types of flails are available for use with these machines, these are shown below;

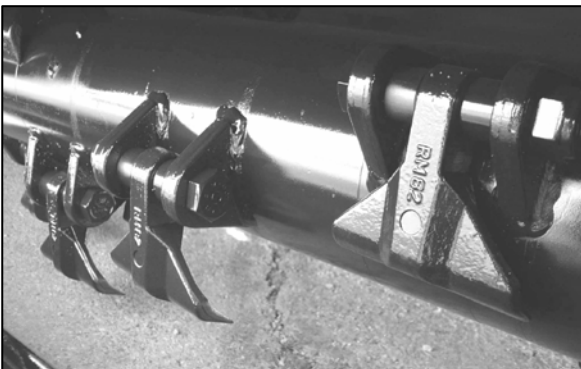

Hammer Flails

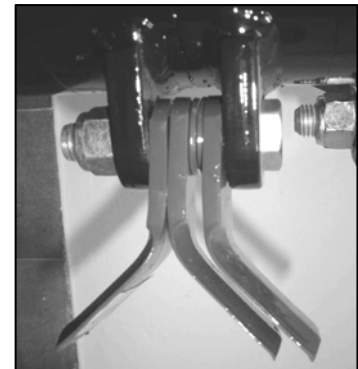

Y-Flails

OPERATION

Ensure that the operator is suitably qualified to use a machine of this nature and that they have fully read and understood this manual - they should be aware of all safety aspects relating to the safe use of the machine. It is advisable that all 'first time' operators practice using the machine in a clear safe area prior to work in order to familiarise themselves with its operation.

After the initial first 2 hours of work with a new machine, nuts and bolts should be checked for tightness and the drive belts inspected and re-tensioned if required – refer to belt section for details.

Prior to starting work the area should be checked for dangerous objects such as large stones, wood, wire, glass etc. – hazardous objects should be removed from the area prior to operation with the machine. The location of unmovable or natural hazards should be noted, or if necessary 'marked', to indicate to the operator that the area should either be avoided or additional caution adopted whilst working around the hazard.

Starting Work

With the machine switched off, lower it into a position approximately 10cm above the ground, start the machine and allow it to build up to the correct working speed before gently lowering it onto the ground - the machine is now in its work position and forward travel can begin.

Forward Speed

The forward working speed will depend on the working conditions and nature of the material being cut. Optimal speed will be in the region of 3-8 km/h (2-5 mph).



Optimal forward working speed 3-8 km/h



Raise the machine before turning or reversing

Reversing & Turning

When reversing or turning the unit the machine must always be lifted clear of the ground to avoid damage.

Transport

The following must be observed at all times when transporting the machine:

- Machine must always be switched off.
- Machine must be raised and placed into its central position.
- Speed must be kept to a minimum especially on bumpy roads or terrain.
- Always abide with local laws and road regulations.
- Be aware of the machines width.

DETACHMENT & STORAGE

Detaching the machine from the tractor

- Removal of the machine should be performed on a firm level site. The procedure for detachment is as follows:
- Place the machine in its central position.
- Gently lower the machine fully to the ground.
- Switch off the tractor and remove its starting key.
- Detach hydraulic hoses from the tractor service and stow them neatly on the machine.
- Remove the PTO driveshaft.
- 'Chock' the rear roller to prevent movement of the machine during the detachment procedure and whilst in storage.
- Remove the top link and both pins from the lower attachment points.
- Carefully and slowly drive the tractor clear of the machine.
- Clean and lubricate the machine in preparation for next use.

Storage

For extended periods of storage it is advisable that the machine be kept in a clean dry environment protected from the elements to avoid risk of corrosion. The machine should be thoroughly cleaned and lubricated prior to storage. At this point it is good practice to check the machine for worn or damaged components - any parts that require replacing should be ordered and fitted at the earliest opportunity so the machine is fully prepared for the next seasons work.

MAINTENANCE

All maintenance, cleaning and repair operations must be performed with the machine firmly lowered to the ground and detached from the tractor or with the PTO disconnected, engine switched off and starting key removed. For any repairs or maintenance that requires access from underneath, the machine should be firmly and safely raised and propped using suitable purpose designed supports capable of bearing the machines full weight. Care should be adopted at all times when working with or under a raised machine.

MAINTENANCE TASKS

The following preventative maintenance tasks should be performed at the timescales stated to both maximise efficiency and prolong the working life of the machine.

After first 2 hours of work - new machine or machine fitted with new belts.

- ✓ Check all nuts and bolt for tightness – *retighten if required.*
- ✓ Check belt tension and adjust if required – *refer to belt section for details of adjustment.*

After every 8 hours of work

- ✓ Check all nuts and bolt for tightness – *retighten if required.*
- ✓ Check belt tension and adjust if required – *refer to belt section for details of adjustment.*
- ✓ Check wear and condition of flails – *replacing missing, or damaged flails immediately.*
- ✓ Check condition of safety guards – *repair or replace if not performing their function.*
- ✓ Lubricate grease points – *see below for locations of the machines grease points.*
- ✓ Check gearbox oil level – *top up if required.*
- ✓ Check rotor – *remove foreign objects that may be fouling or lodged in the rotor.*
- ✓ Check frame and 3-point hitch – *ensure all components are in a safe working condition.*

After every 100 hours

- ✓ Grease PTO driveshaft – *separate telescopic drive and apply grease to internal shaft.*

Every 12 months

- ✓ Change gearbox oil

Grease Points

Lubricate the points indicated below using type LIS 3 grease.

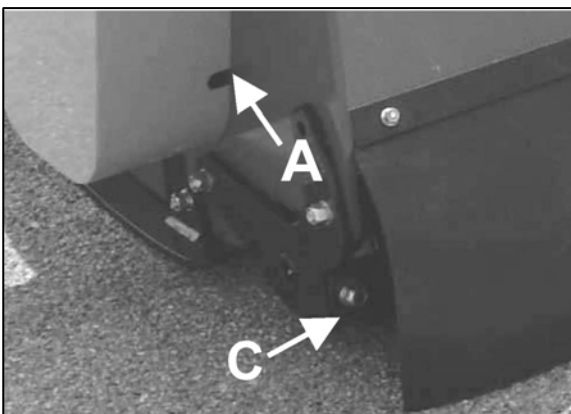

A. Rotor Shaft L/H Bearing
C. Rear Roller L/H Bearing

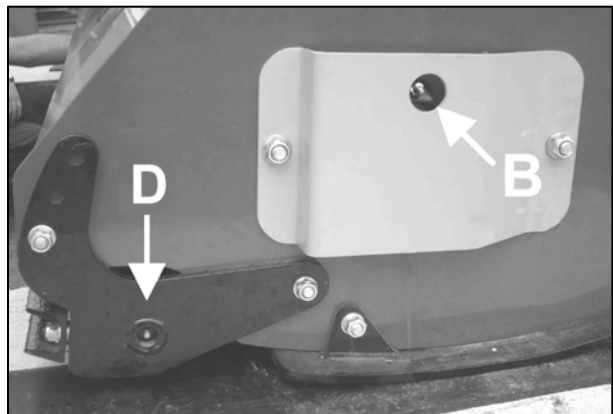

B. Rotor Shaft R/H Bearing
D. Rear Roller R/H Bearing

Gearbox Lubrication

The illustrations opposite show the lubrication access points for the gearbox and the half shaft drive.

- A. Filler Plug
- B. Level Plug
- C. Drain Plug

Lubricant level should be checked on a daily basis during work and topped up only if required.

Checking the level is by removal of plug 'B' – lubricant should be inline with the bottom of this aperture. Topping up the lubricant is performed via filler plug 'A' to a point where the oil starts to drip out of plug 'B' aperture. Replace and tighten the plugs before using the machine.

Gearbox oil should be replaced annually – draining the gearbox is via plug 'C'.

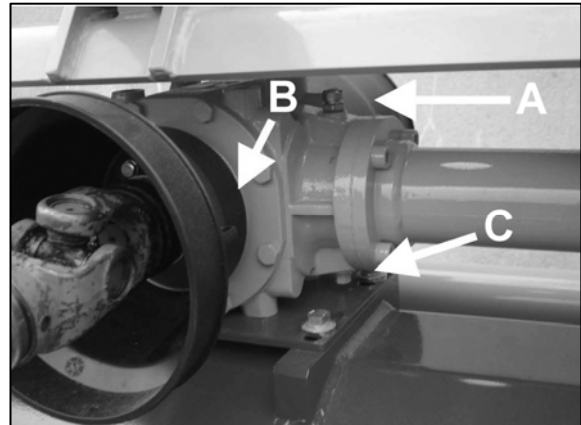

Gearbox - lubrication access points

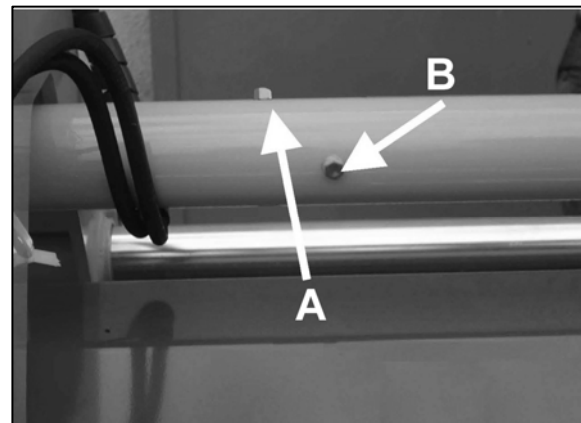

Half Shaft - lubrication access points

Capacities & Lubricant

Gearbox

1.5 Litre SAE90 – *All models*

Half Shaft

0.9 Litre SAE90 – *Euro 230 & Euro 250 models*

1.3 Litre SAE90 – *Euro 280 model*

Flail replacement

The rotor and flails should be inspected for wear or damage on a regular basis – missing, damaged or worn flails should be replaced immediately. When replacing a flail the diametrically opposite flail should also be replaced at the same time in order to maintain rotor balance.

DANGER: Machine and tractor should be switched off and the starting key removed at all times when inspecting or maintaining the machine – Never work on a machine that is switch on and running.

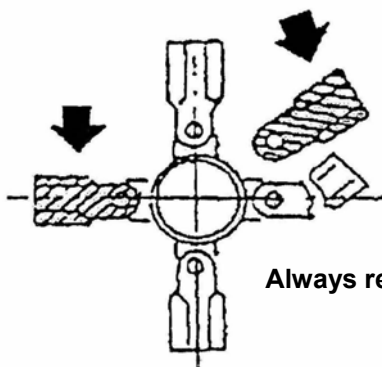

Always replace flails in opposing pairs

Rotor Vibration

If vibration of the rotor is experienced the machine should be stopped immediately – this is often a sign that a flail is either missing or severely damaged, if this is the case do not use the machine until the problem has been rectified. If vibration continues, or occurs for no apparent reason, the rotor must be checked and, if necessary, rebalanced before using the machine again. Contact your local dealer for further advice or assistance on this subject.

TROUBLESHOOTING

| PROBLEM | POSSIBLE CAUSES | REMEDIES |
|-------------------------------------|--|------------------------------------|
| Irregular Cut | Worn, bent or broken flails | <i>Replace flails</i> |
| | RPM too low | <i>Increase RPM</i> |
| | Machine not level to the ground | <i>Correct mounting on tractor</i> |
| | Clogged material caused by excessive forward speed | <i>Reduce forward speed</i> |
| Noise | Loose bolts | <i>Check and tighten bolts</i> |
| | Damaged components | <i>Repair or replace</i> |
| Noisy gearbox | Lack of lubrication | <i>Top up oil to correct level</i> |
| | Worn gears | <i>Replace worn components</i> |
| | Worn bearings | <i>Replace worn components</i> |
| Vibration | Broken, worn or missing flails | <i>Replace flails</i> |
| | Rotor out of balance | <i>Balance or replace rotor</i> |
| | Worn rotor bearings | <i>Replace rotor bearings</i> |
| Excessive backlash in joints | Worn pins | <i>Replace pins</i> |
| Tight bearings | Bearings dirty or ungreased | <i>Clean and grease</i> |
| | Violent lowering down of machine | <i>Lower machine gently</i> |
| Belts overheating | Belts slipping on pulleys | <i>Tension belts</i> |
| | Flails contacting the ground | <i>Raise cutting height</i> |
| | Working speed too high | <i>Reduce working speed</i> |

Machine Disposal

Disposal of this machine and any of its component parts must be performed in a responsible and inoffensive manner respecting all current laws relating to this subject. Materials forming this machine that must undergo differentiated division and disposal are:

- Steel
- Mineral Oil
- Rubber
- Plastic

MAGNUM

**EURO & EURO OPEN
230 / 250 / 280 Series**

**Parts Manual
Builds 04/09 - 03/14**

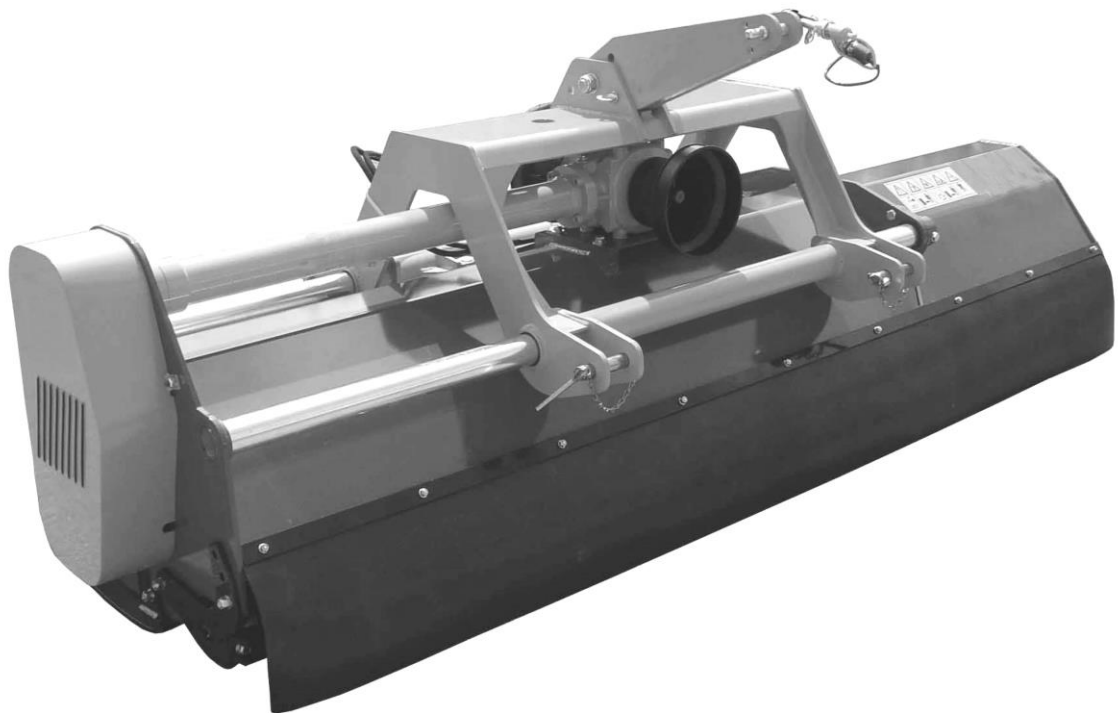

Module(s): 1061970, 1061971, 1061972

Taper Lock torque setting = 45Nm

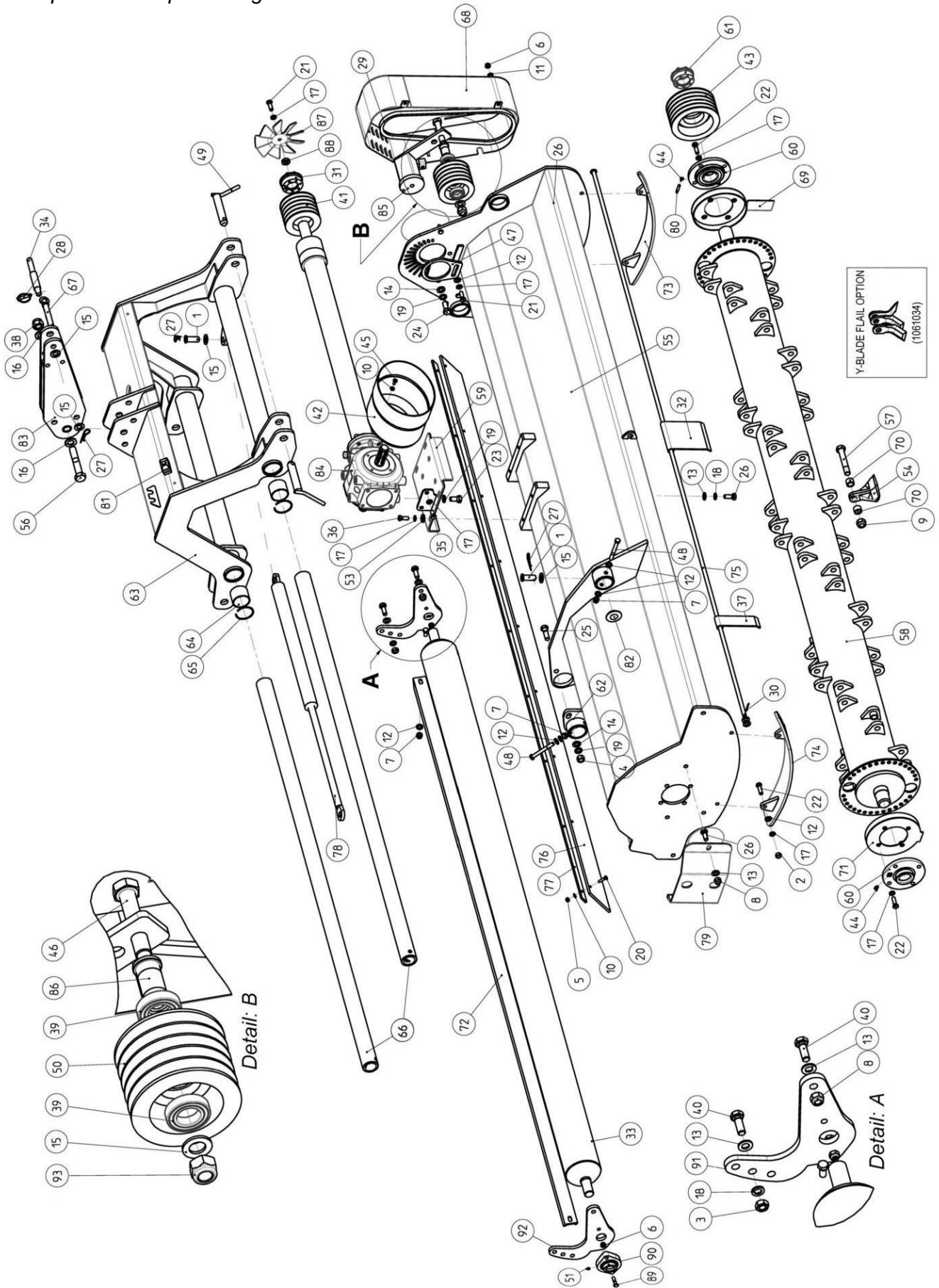

Module(s): 1061970, 1061971, 1061972

| REF. | DESCRIPTION | PART No. | QUANTITY | | |
|------|------------------|-----------|----------|-----|-----|
| | | | 230 | 250 | 280 |
| 1 | PIVOT PIN | 1061532 | 2 | 2 | 2 |
| 2 | NUT | 9163006 | 4 | 4 | 4 |
| 3 | NUT | 1061121 | 2 | 2 | 2 |
| 4 | NUT | 9163007 | 2 | 2 | 2 |
| 5 | SELF-LOCKING NUT | 9143004 | 7 | 8 | 9 |
| 6 | SELF-LOCKING NUT | 9143005 | 3 | 3 | 3 |
| 7 | SELF-LOCKING NUT | 9163006 | 4 | 4 | 4 |
| 8 | SELF-LOCKING NUT | 1061042 | 4 | 4 | 4 |
| 9 | NUT | 1062306 | 26 | 28 | 32 |
| 10 | WASHER | 9100104 | 15 | 16 | 17 |
| 11 | WASHER | 9100105 | 3 | 3 | 3 |
| 12 | WASHER | 9100106 | 11 | 11 | 11 |
| 13 | WASHER | 05.281.14 | 17 | 17 | 17 |
| 14 | WASHER | 0100106 | 3 | 3 | 3 |
| 15 | WASHER | 9100108 | 5 | 5 | 5 |
| 16 | WASHER | 9100109 | 2 | 2 | 2 |
| 17 | SPRING WASHER | 9100206 | 10 | 10 | 10 |
| 18 | SPRING WASHER | 05.282.08 | 20 | 20 | 20 |
| 19 | SPRING WASHER | 9100207 | 7 | 7 | 7 |
| 20 | BOLT | 9213064 | 7 | 8 | 9 |
| 21 | BOLT | 9313076 | 2 | 2 | 2 |
| 22 | BOLT | 9213086 | 12 | 12 | 12 |
| 23 | BOLT | 1061533 | 4 | 4 | 4 |
| 24 | BOLT | 1061047 | 1 | 1 | 1 |
| 25 | BOLT | 9213107 | 2 | 2 | 2 |
| 26 | BOLT | 9313148 | 10 | 10 | 12 |
| 27 | PIN | 1061076 | 3 | 3 | 3 |
| 28 | PIVOT PIN | 1061097 | 1 | 1 | 1 |
| 29 | BELT | 21233.01 | 4 | 5 | 5 |
| 30 | SPLIT PIN | 1061077 | 1 | 1 | 1 |
| 31 | CLUTCH ELVE | 1061165 | 1 | 1 | 1 |
| 32 | FLAP (140mm) | 1061171 | 16 | 12 | 19 |
| 33 | REAR ROLLER 280 | 1061696 | - | - | 1 |
| | REAR ROLLER 250 | 1061697 | - | 1 | - |
| | REAR ROLLER 230 | 1061698 | 1 | - | - |
| 34 | PIVOT PIN | 1061168 | 1 | 1 | 1 |
| 35 | BOLT | 9313056 | 2 | 2 | 2 |
| 36 | BOLT | 9213066 | 4 | 4 | 4 |
| 37 | FLAP 50 | 1061482 | - | - | 1 |
| | FLAP 130 | 1061098 | - | 5 | - |
| | FLAP 70 | 1061170 | - | 1 | - |
| 38 | SELF-LOCKING NUT | 9143009 | 1 | 1 | 1 |
| 39 | BEARING | 1061336 | 2 | 2 | 2 |
| 40 | BOLT | 1061092 | 4 | 4 | 4 |
| 41 | PULLEY 130/80-5 | 1061479 | - | 1 | 1 |
| | PULLEY 130/80-4 | 1061113 | 1 | - | - |

Taper Lock torque setting = 45Nm

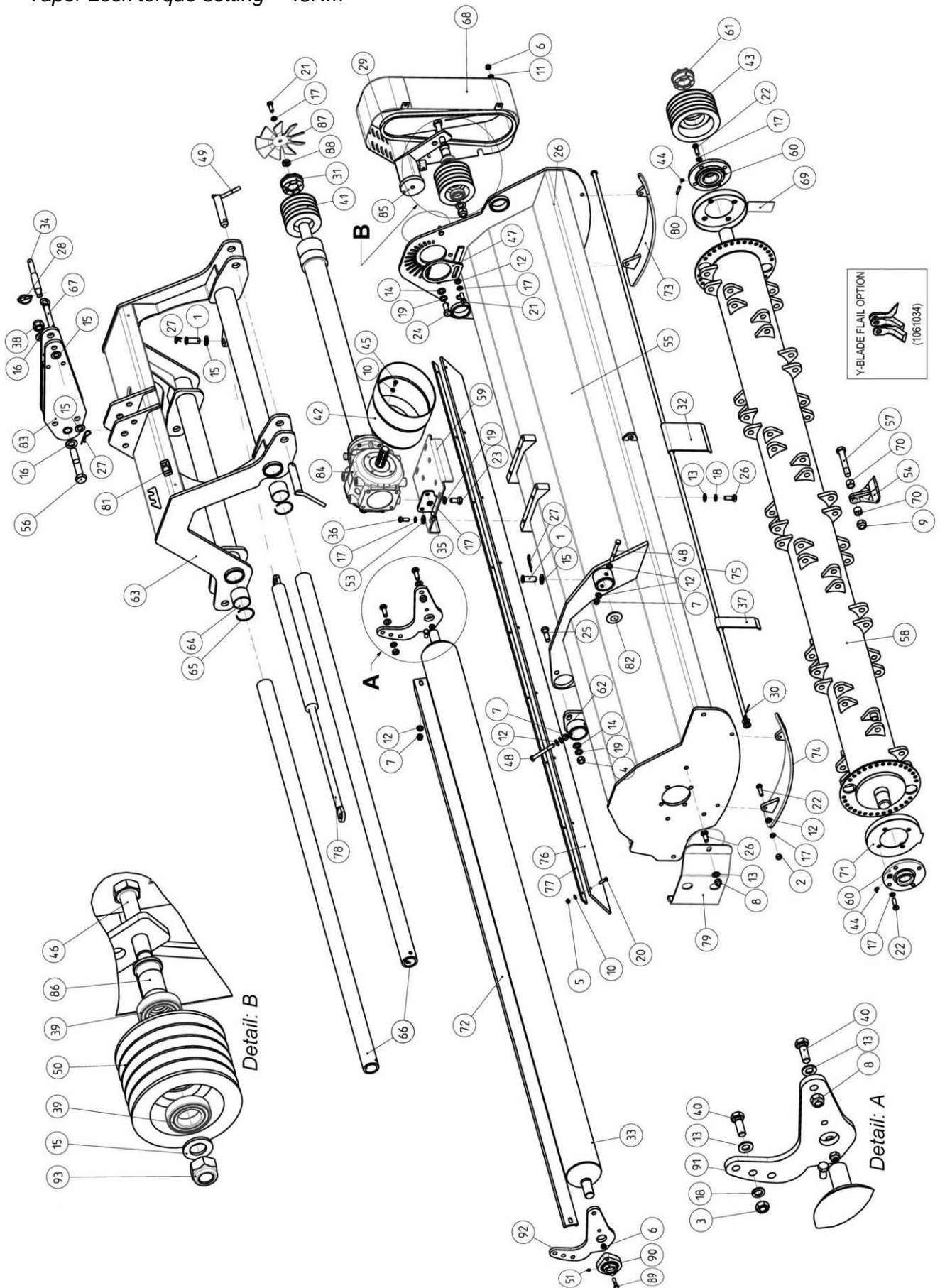

Module(s): 1061970, 1061971, 1061972

| REF. | DESCRIPTION | PART No. | QUANTITY | | |
|------|-----------------------------|----------|----------|-----|-----|
| | | | 230 | 250 | 280 |
| 42 | PTO SHAFT SHIELD | 1061484 | 2 | 2 | 2 |
| 43 | PULLEY 180/80-5 | 1061414 | - | 1 | 1 |
| | PULLEY 180/80-4 | 1061114 | 1 | - | - |
| 44 | GREASER | 1061483 | 2 | 2 | 2 |
| 45 | BOLT | 9313034 | 8 | 8 | 8 |
| 46 | BOLT | 1061555 | - | 1 | 1 |
| | BOLT | 1061556 | 1 | - | - |
| 47 | GEARBOX FLANGE | 1061142 | 1 | 1 | 1 |
| 48 | BOLT | 9213206 | 2 | 2 | 2 |
| 49 | PIVOT PIN c/w CHAIN & PIN | 1061268 | 2 | 2 | 2 |
| 50 | PULLEY 130/5 | 1061335 | - | 1 | 1 |
| | PULLEY 130/4 | 1061049 | 1 | - | - |
| 51 | GREASER | 1061674 | 2 | 2 | 2 |
| 52 | STRAINER | 1061539 | 1 | 1 | 1 |
| 53 | WASHER | 1062112 | 4 | 4 | 4 |
| 54 | HAMMER FLAIL | 1061371 | 26 | 28 | 32 |
| | Y-BLADE FLAIL (OPTION) | 1061034 | 78 | 84 | 96 |
| 55 | FRAME - EURO 280 | 1061488 | - | - | 1 |
| | FRAME - EURO 250 | 1061487 | - | 1 | - |
| | FRAME - EURO 230 | 1061486 | 1 | - | - |
| 56 | BOLT | 1061557 | 1 | 1 | 1 |
| 57 | BOLT | 1062305 | 26 | 28 | 32 |
| 58 | ROTOR SHAFT - EURO 280 | 1061528 | - | - | 1 |
| | ROTOR SHAFT - EURO 250 | 1061527 | - | 1 | - |
| | ROTOR SHAFT - EURO 230 | 1061526 | 1 | - | - |
| 59 | GEARBOX PLATE | 1061694 | 1 | 1 | 1 |
| 60 | BEARING WITH CASING | 1061489 | 2 | 2 | 2 |
| 61 | CLUTCH ELVE | 1061490 | 1 | 1 | 1 |
| 62 | SLEEVE | 1061491 | 1 | 1 | 1 |
| 63 | LINKAGE | 1061492 | 1 | 1 | 1 |
| 64 | BUSHING | 1061493 | 4 | 4 | 4 |
| 65 | SPRING RING | 1061494 | 4 | 4 | 4 |
| 66 | SLIDING TUBE | 1061496 | - | - | 2 |
| | SLIDING TUBE | 1061495 | 2 | 2 | - |
| 67 | PIVOT PIN | 1061498 | 1 | 1 | 1 |
| 68 | BELT SHIELD | 1061529 | 1 | 1 | 1 |
| 69 | FIXING RING (ROTOR SHAFT L) | 1061499 | 1 | 1 | 1 |
| 70 | SPACER | 1061501 | 52 | 56 | 64 |
| 71 | FIXING RING (ROTOR SHAFT R) | 1061500 | 1 | 1 | 1 |
| 72 | SCRAPER - EURO 280 | 1061509 | - | - | 1 |
| | SCRAPER - EURO 250 | 1061508 | - | 1 | - |
| | SCRAPER - EURO 230 | 1061507 | 1 | - | - |
| 73 | SKID (LEFT) | 1061510 | 1 | 1 | 1 |
| 74 | SKID (RIGHT) | 1061511 | 1 | 1 | 1 |
| 75 | FLAP BAR 280 | 1061514 | - | - | 1 |
| | FLAP BAR 250 | 1061513 | - | 1 | - |
| | FLAP BAR 230 | 1061512 | 1 | - | - |

Taper Lock torque setting = 45Nm

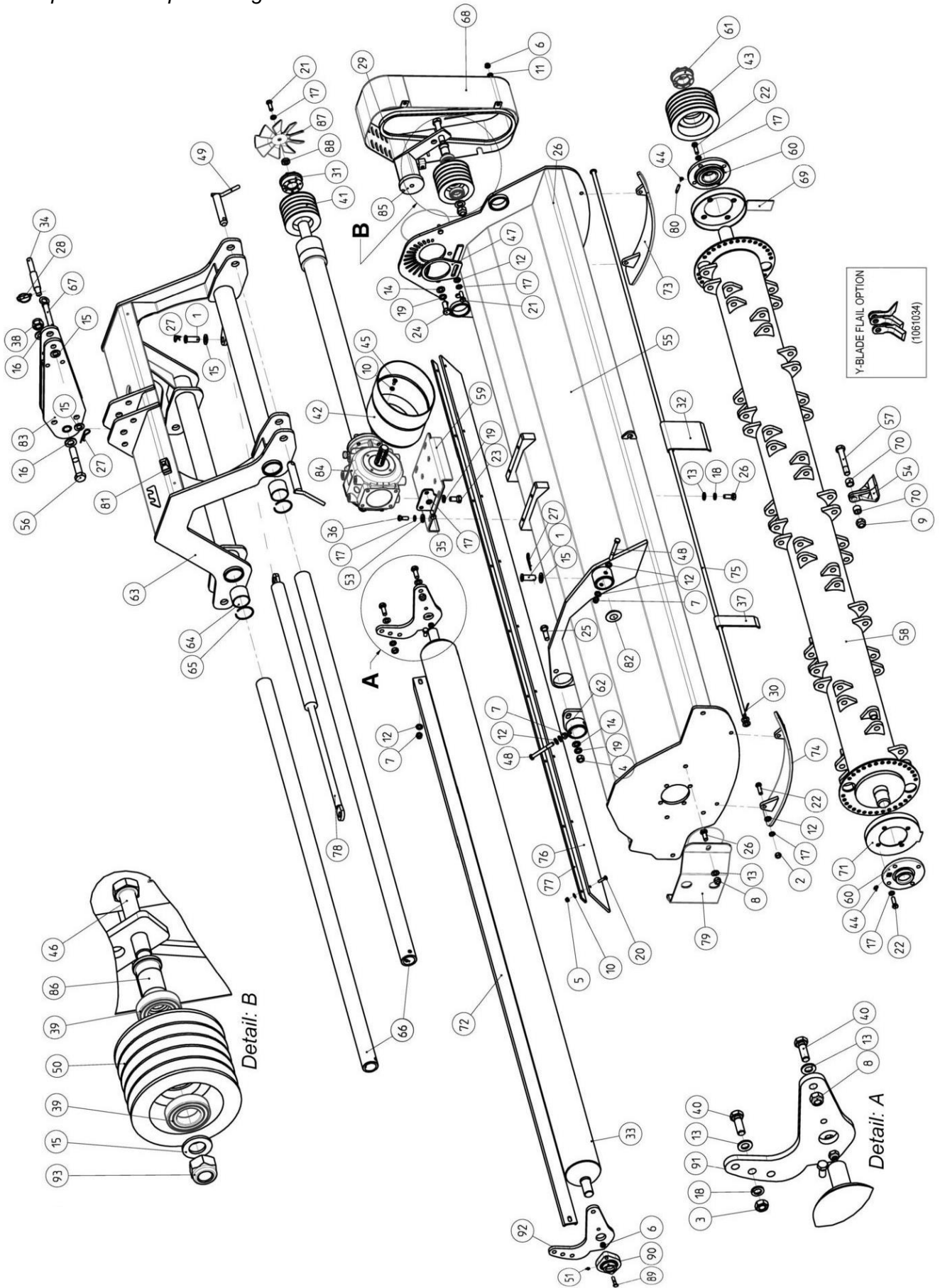

Module(s): 1061970, 1061971, 1061972

| REF. | DESCRIPTION | PART No. | QUANTITY | | |
|------|-----------------------------------|----------|----------|-----|-----|
| | | | 230 | 250 | 280 |
| 76 | RUBBER GUARD - EURO 280 | 1061517 | - | - | 1 |
| | RUBBER GUARD - EURO 250 | 1061516 | - | 1 | - |
| | RUBBER GUARD - EURO 230 | 1061515 | 1 | - | - |
| 77 | BAR (RUBBER GUARD) - 280 | 1061520 | - | - | 1 |
| | BAR (RUBBER GUARD) - 250 | 1061519 | - | 1 | - |
| | BAR (RUBBER GUARD) - 230 | 1061518 | 1 | - | - |
| 78 | HYDRAULIC CYLINDER | 1061523 | 1 | 1 | 1 |
| 79 | BEARING GUARD | 1061522 | 1 | 1 | 1 |
| 80 | GREASE NIPPLE EXTENSION | 1061558 | 1 | 1 | 1 |
| 81 | CLAMP | 1061559 | 1 | 1 | 1 |
| 82 | CAP | 1061561 | 4 | 4 | 4 |
| 83 | UPPER LINKAGE | 1061562 | 1 | 1 | 1 |
| 84 | GEARBOX 312 1200 | 1061692 | - | - | 1 |
| | GEARBOX 312 950 | 1061693 | 1 | 1 | - |
| 85 | STRAINER | 1061563 | - | 1 | 1 |
| | STRAINER | 1061564 | 1 | - | - |
| 86 | BUSHING FOR STRAIN PULLEY | 1061565 | - | 1 | 1 |
| | BUSHING FOR STRAIN PULLEY | 1061622 | 1 | - | - |
| 87 | FAN | 1061566 | 1 | 1 | 1 |
| 88 | BUSH | 1061573 | 1 | 1 | 1 |
| 89 | BOLT | 9213105 | 4 | 4 | 4 |
| 90 | BEARING BLOCK | 1061695 | 2 | 2 | 2 |
| 91 | REAR ROLLER BRACKET LH | 1061699 | 1 | 1 | 1 |
| 92 | REAR ROLLER BRACKET RH | 1062001 | 1 | 1 | 1 |
| 93 | NUT | 1061343 | 1 | 1 | 1 |
| * | HYDRAULIC OFFSETTING PIPES (2000) | 1061581 | 1 | 1 | 1 |
| * | HYDRAULIC OFFSETTING PIPES (2500) | 1061582 | 1 | 1 | 1 |
| * | PTO SHAFT | 1061690 | 1 | 1 | 1 |

* *Components not illustrated*

Module(s): 1061980, 1061981, 1061982

Taper Lock torque setting = 45Nm

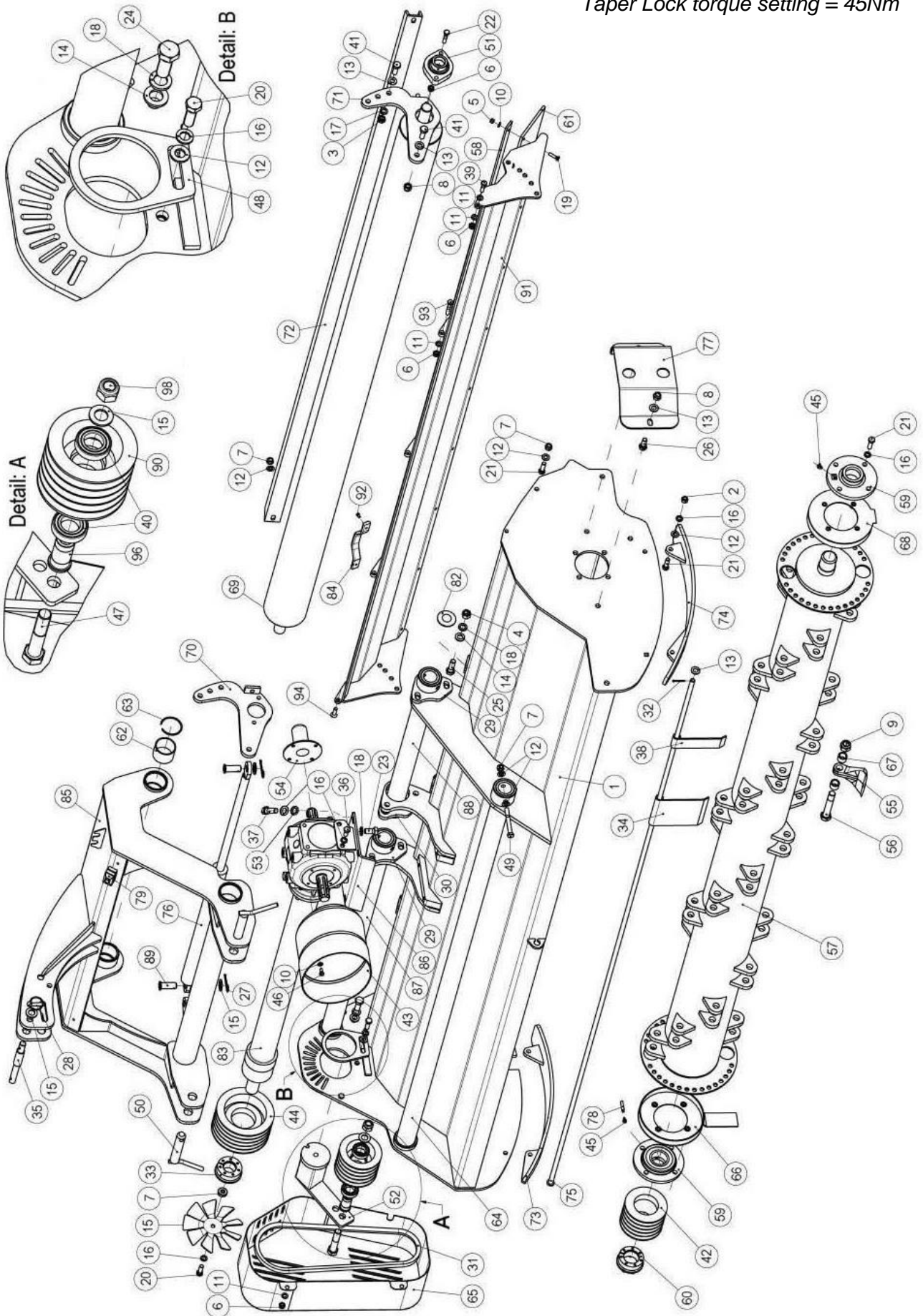

Module(s): 1061980, 1061981, 1061982

| REF. | DESCRIPTION | PART No. | QUANTITY | | |
|------|-----------------|-----------|----------|-----|-----|
| | | | 230 | 250 | 280 |
| 1 | FRAME 230 | 1062122 | 1 | - | - |
| | FRAME 250 | 1062123 | - | 1 | - |
| | FRAME 280 | 1062124 | - | - | 1 |
| 2 | NUT | 9163006 | 11 | 11 | 11 |
| 3 | NUT | 1061121 | 2 | 2 | 2 |
| 4 | NUT | 9163007 | 2 | 2 | 2 |
| 5 | NUT | 9163004 | 7 | 8 | 9 |
| 6 | NUT | 9163005 | 6 | 6 | 6 |
| 7 | BUSHING | 1061573 | 1 | 1 | 1 |
| 8 | NUT | 1061042 | 6 | 6 | 6 |
| 9 | NUT | 1062306 | 26 | 28 | 32 |
| 10 | WASHER | 9100104 | 15 | 16 | 17 |
| 11 | WASHER | 9100105 | 12 | 12 | 12 |
| 12 | WASHER | 9100106 | 19 | 19 | 19 |
| 13 | WASHER | 9100108 | 23 | 23 | 25 |
| 14 | WASHER | 1000106 | 7 | 7 | 7 |
| 15 | FAN | 1062128 | 1 | 1 | 1 |
| 16 | WASHER | 9100206 | 18 | 18 | 18 |
| 17 | WASHER | 05.282.08 | 12 | 12 | 12 |
| 18 | WASHER | 9100207 | 11 | 11 | 11 |
| 19 | BOLT | 9213064 | 7 | 8 | 9 |
| 20 | BOLT | 9313076 | 2 | 2 | 2 |
| 21 | BOLT | 9213086 | 12 | 12 | 12 |
| 22 | BOLT | 9213105 | 4 | 4 | 4 |
| 23 | BOLT | 9313067 | 4 | 4 | 4 |
| 24 | BOLT | 1061047 | 1 | 1 | 1 |
| 25 | BOLT | 9213107 | 2 | 2 | 2 |
| 26 | BOLT | 9313148 | 10 | 10 | 12 |
| 27 | PIN | 1061076 | 2 | 2 | 2 |
| 28 | PIN | 1061097 | 1 | 1 | 1 |
| 29 | BUSHING - LEFT | 1062136 | 2 | 2 | 2 |
| 30 | BUSHING - RIGHT | 1062137 | 1 | 1 | 1 |
| 31 | BELT | 21233.01 | 4 | 5 | 5 |
| 32 | SPLIT PIN | 1061077 | 1 | 1 | 1 |
| 33 | CLUTCH ELVE | 1061165 | 1 | 1 | 1 |
| 34 | FLAP | 1061171 | 16 | 12 | 19 |
| 35 | CONNECTION PIN | 1061168 | 1 | 1 | 1 |
| 36 | BOLT | 9313056 | 2 | 2 | 2 |
| 37 | BOLT | 9213066 | 4 | 4 | 4 |
| 38 | FLAP 50 | 1061482 | - | - | 1 |
| | FLAP 70 | 1061170 | - | 1 | - |
| | FLAP 130 | 1061098 | - | 5 | - |
| 39 | BOLT | 9213085 | 1 | 1 | 1 |

Module(s): 1061980, 1061981, 1061982

Taper Lock torque setting = 45Nm

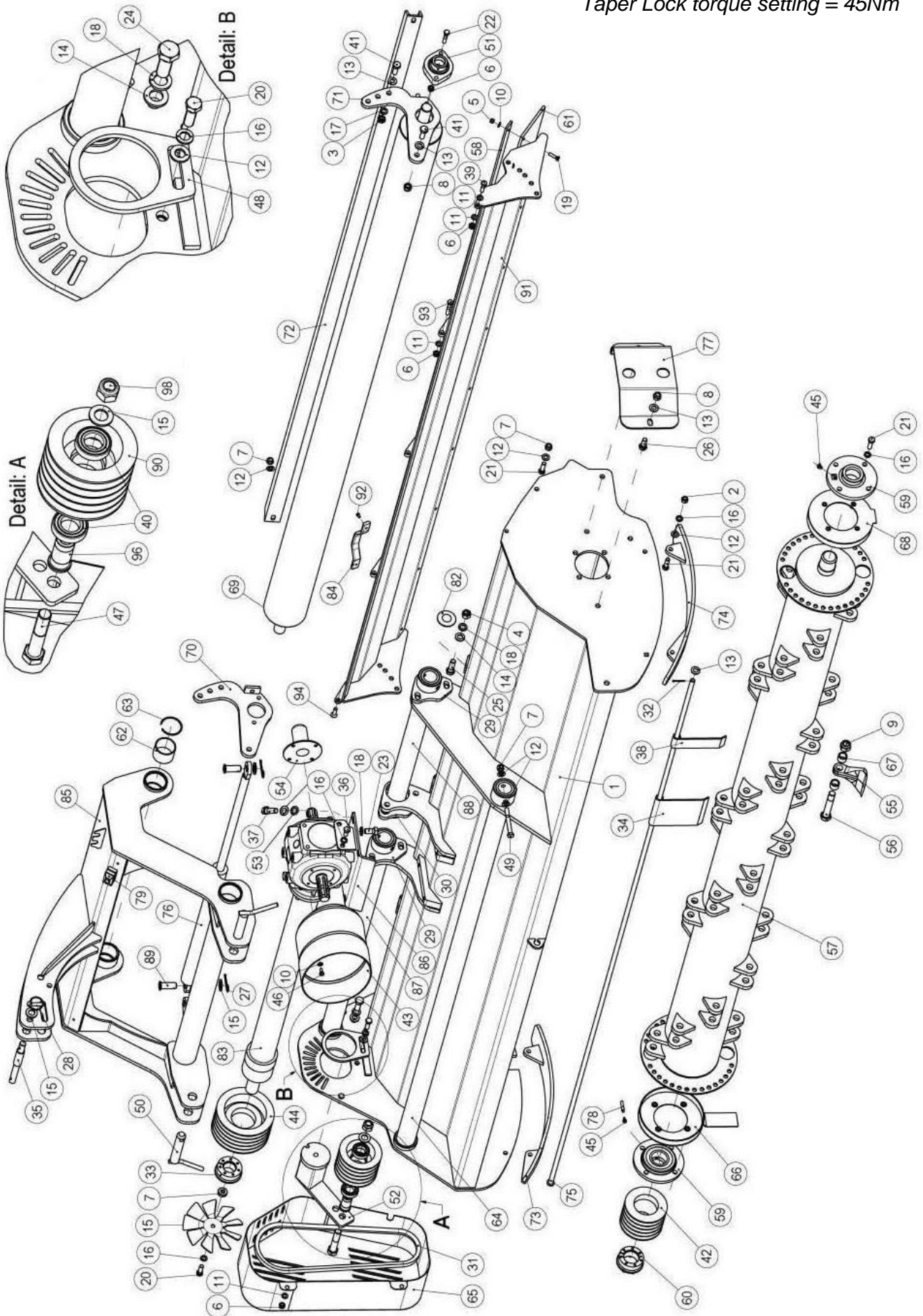

Module(s): 1061980, 1061981, 1061982

| REF. | DESCRIPTION | PART No. | QUANTITY | | |
|------|----------------------|----------|----------|-----|-----|
| | | | 230 | 250 | 280 |
| 40 | BEARING | 1061336 | 2 | 2 | 2 |
| 41 | BOLT | 1061687 | 4 | 4 | 4 |
| 42 | PULLEY | 1061113 | 1 | - | - |
| | PULLEY | 1061479 | - | 1 | 1 |
| 43 | PTO SHAFT SHIELD | 1061246 | 2 | 2 | 2 |
| 44 | PULLEY | 1061114 | 1 | - | - |
| | PULLEY | 1061414 | - | 1 | 1 |
| 45 | GREASE NIPPLE | 1061483 | 2 | 2 | 2 |
| 46 | BOLT | 1061531 | 8 | 8 | 8 |
| 47 | BOLT | 1061556 | 1 | - | - |
| | BOLT | 1061555 | - | 1 | 1 |
| 48 | FLANGE | 1061142 | 1 | 1 | 1 |
| 49 | BOLT | 9213206 | 2 | 2 | 2 |
| 50 | PIN | 1061268 | 2 | 2 | 2 |
| 51 | BEARING WITH CASING | 1062138 | 2 | 2 | 2 |
| 52 | BELT TENSIONER | 1061539 | 1 | 1 | 1 |
| 53 | WASHER | 1062112 | 4 | 4 | 4 |
| 54 | CAP | 1061552 | 1 | 1 | 1 |
| 55 | HAMMER | 1061371 | 26 | 28 | 32 |
| 56 | BOLT | 1062305 | 26 | 28 | 32 |
| 57 | ROTOR SHAFT 230 | 1061580 | 1 | - | - |
| | ROTOR SHAFT 250 | 1061579 | - | 1 | - |
| | ROTOR SHAFT 280 | 1061578 | - | - | 1 |
| 58 | BAR 230 | 1062133 | 1 | - | - |
| | BAR 250 | 1062134 | - | 1 | - |
| | BAR 280 | 1062135 | - | - | 1 |
| 59 | BEARING WITH CASING | 1061489 | 2 | 2 | 2 |
| 60 | CLUTCH ELVE | 1061490 | 1 | 1 | 1 |
| 61 | RUBBER GUARD 230 | 1062130 | 1 | - | - |
| | RUBBER GUARD 250 | 1062131 | - | 1 | - |
| | RUBBER GUARD 280 | 1062132 | - | - | 1 |
| 62 | BUSHING | 1061493 | 4 | 4 | 4 |
| 63 | SPRING RING | 1061494 | 4 | 4 | 4 |
| 64 | SLIDING TUBE 230/250 | 1061495 | 1 | 1 | - |
| | SLIDING TUBE 280 | 1061496 | - | - | 1 |
| 65 | BELT SHIELD | 1061571 | 1 | 1 | 1 |
| 66 | FIXING RING - L | 1061499 | 1 | 1 | 1 |
| 67 | SPACER | 1061501 | 52 | 56 | 64 |
| 68 | FIXING RING - R | 1061500 | 1 | 1 | 1 |
| 69 | REAR ROLLER 230 | 1061502 | 1 | - | - |
| | REAR ROLLER 250 | 1061503 | - | 1 | - |
| | REAR ROLLER 280 | 1061504 | - | - | 1 |

Module(s): 1061980, 1061981, 1061982

Taper Lock torque setting = 45Nm

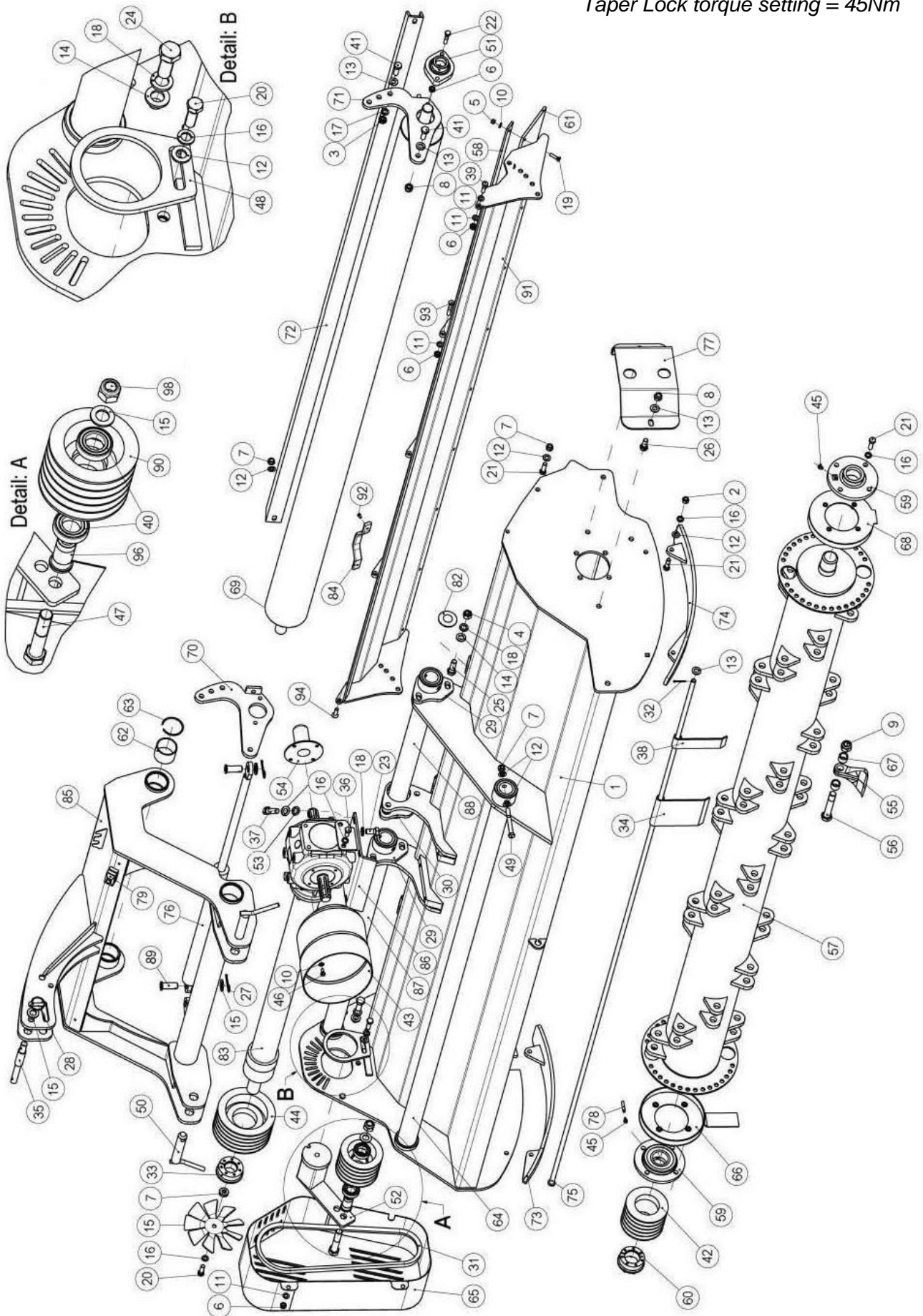

Module(s): 1061980, 1061981, 1061982

| REF. | DESCRIPTION | PART No. | QUANTITY | | |
|------|---|----------|----------|-----|-----|
| | | | 230 | 250 | 280 |
| 70 | ROLLER BRACKET RH | 1062001 | 1 | 1 | 1 |
| 71 | ROLLER BRACKET LH | 1061699 | 1 | 1 | 1 |
| 72 | SCRAPER 230 | 1061507 | 1 | - | - |
| | SCRAPER 250 | 1061508 | - | 1 | - |
| | SCRAPER 280 | 1061509 | - | - | 1 |
| 73 | SKID - RIGHT | 1061511 | 1 | 1 | 1 |
| 74 | SKID - LEFT | 1061510 | 1 | 1 | 1 |
| 75 | FLAP BAR 230 | 1061512 | 1 | - | - |
| | FLAP BAR 250 | 1061513 | - | 1 | - |
| | FLAP BAR 280 | 1061514 | - | - | 1 |
| 76 | HYDRAULIC RAM | 1061523 | 1 | 1 | 1 |
| 77 | BEARING SHIELD | 1061522 | 1 | 1 | 1 |
| 78 | NIPPLE EXTENSION | 1061558 | 1 | 1 | 1 |
| 79 | CLAMP | 1061559 | 1 | 1 | 1 |
| 80 | HYDRAULIC HOSE - <i>not illustrated</i> | 1061581 | 1 | 1 | 1 |
| 81 | HYDRAULIC HOSE - <i>not illustrated</i> | 1061582 | 1 | 1 | 1 |
| 82 | CAP | 1061561 | 4 | 4 | 4 |
| 83 | GEARBOX | 1061575 | 1 | 1 | - |
| | GEARBOX | 1061574 | - | - | 1 |
| 84 | HANDLE | 1062152 | 1 | 1 | 1 |
| 85 | LINKAGE | 1062153 | 1 | 1 | 1 |
| 86 | GEARBOX PLATE | 1062118 | 1 | 1 | 1 |
| 87 | SLIDING TUBE 280 | 1062119 | - | - | 1 |
| 88 | SLIDING TUBE 230/250 | 1062120 | 2 | 2 | - |
| | SLIDING TUBE 280 | 1062121 | - | - | 1 |
| 89 | PIN | 1061532 | 2 | 2 | 2 |
| 90 | STRAIN PULLEY | 1061049 | 1 | - | - |
| | STRAIN PULLEY | 1061335 | - | 1 | 1 |
| 91 | REAR GATE 230 | 1062125 | 1 | - | - |
| | REAR GATE 250 | 1062126 | - | 1 | - |
| | REAR GATE 280 | 1062127 | - | - | 1 |
| 92 | BOLT | 9313013 | 4 | 4 | 4 |
| 93 | BOLT | 1062129 | 3 | 3 | 3 |
| 94 | BOLT | 9313075 | 1 | 1 | 1 |
| 95 | BELT TENSIONER ASSEMBLY 230 | 1061564 | 1 | - | - |
| | BELT TENSIONER ASSEMBLY 250/280 | 1061563 | - | 1 | 1 |
| 96 | PIVOT PIN | 1061622 | 1 | - | - |
| | PIVOT PIN | 1061565 | - | 1 | 1 |
| 97 | DECAL KIT - MAGNUM EURO 230 | 1061710 | 1 | - | - |
| | DECAL KIT - MAGNUM EURO 250 | 1061711 | - | 1 | - |
| | DECAL KIT - MAGNUM EURO 280 | 1061712 | - | - | 1 |
| 98 | NUT | 1061343 | 1 | 1 | 1 |
| * | PTO SHAFT | 1062246 | 1 | - | - |
| * | PTO SHAFT | 1061690 | - | 1 | 1 |

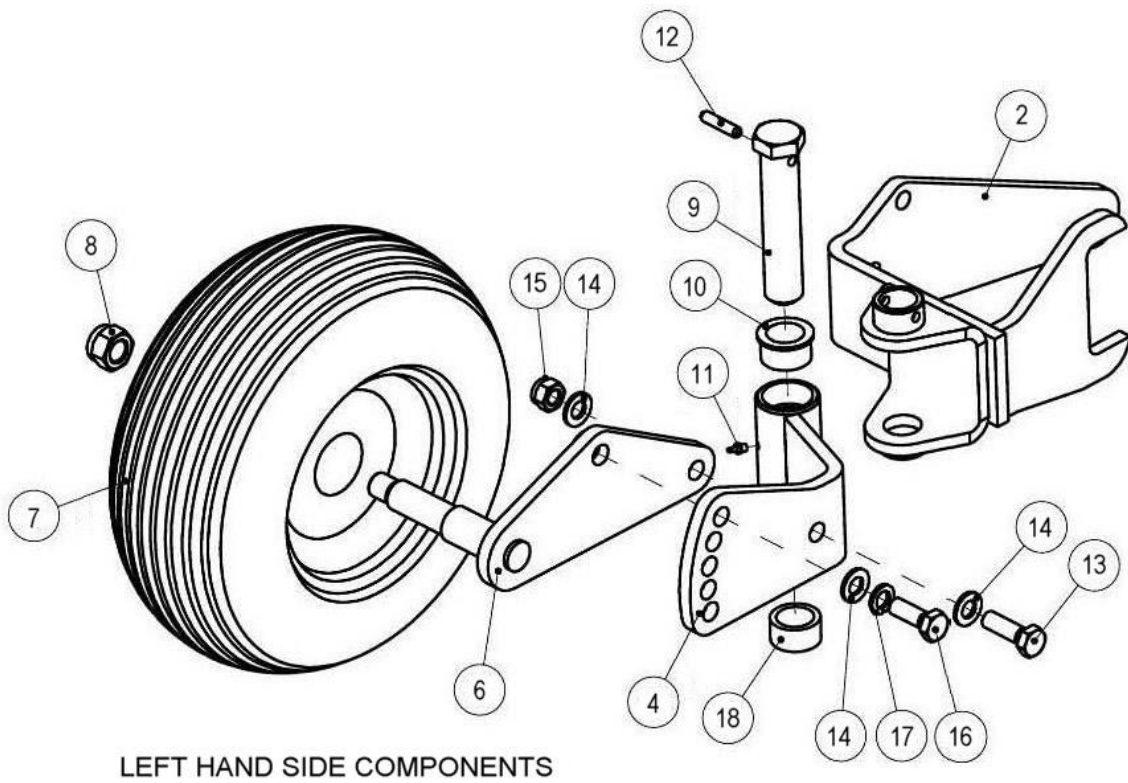
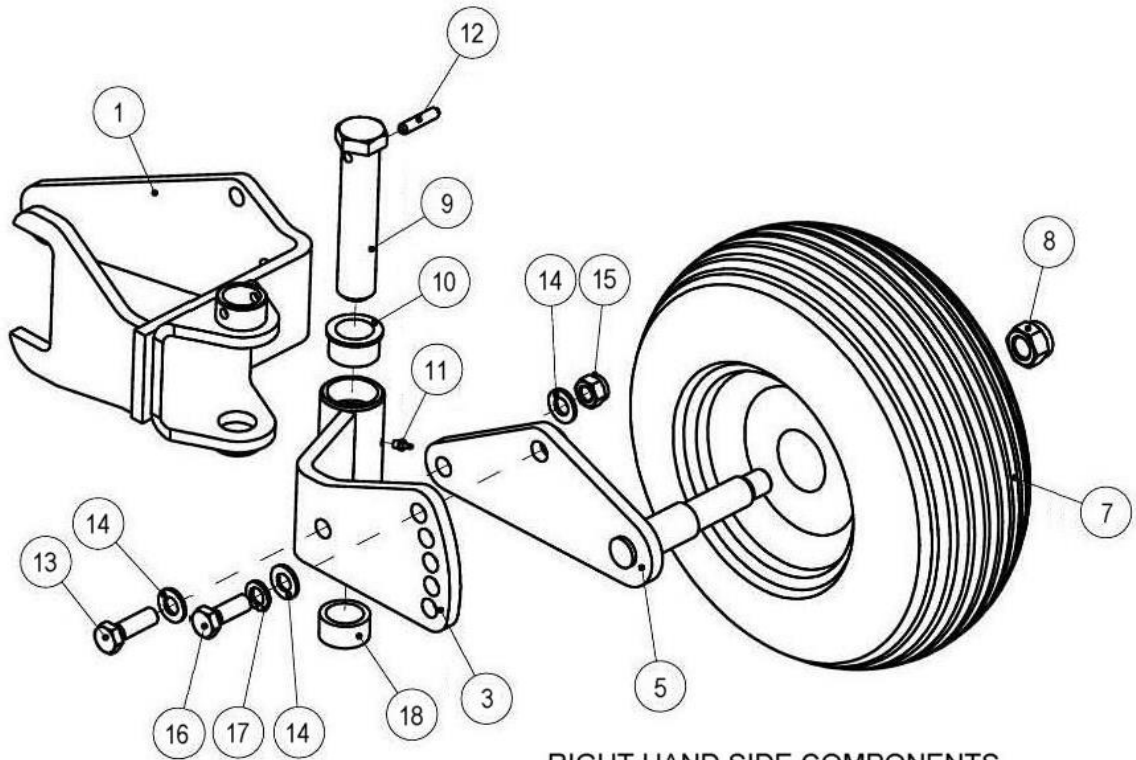

| REF. | DESCRIPTION | PART No. | QUANTITY | | |
|------|--------------------------------------|----------------|----------|-----|-----|
| | | | 230 | 250 | 280 |
| | SUPPORT WHEEL MODULE (OPTION) | 1062150 | | | |
| 1 | BRACKET SUPPORT RH | 1062147 | 1 | 1 | 1 |
| 2 | BRACKET SUPPORT LH | 1062148 | 1 | 1 | 1 |
| 3 | WHEEL BRACKET RH | 1062143 | 1 | 1 | 1 |
| 4 | WHEEL BRACKET LH | 1062144 | 1 | 1 | 1 |
| 5 | WHEEL AXLE RH | 1062145 | 1 | 1 | 1 |
| 6 | WHEEL AXLE LH | 1062146 | 1 | 1 | 1 |
| 7 | WHEEL | 1062139 | 2 | 2 | 2 |
| 8 | NUT | 9113008 | 2 | 2 | 2 |
| 9 | PIN | 1062141 | 2 | 2 | 2 |
| 10 | BUSHING | 1062142 | 2 | 2 | 2 |
| 11 | GREASE NIPPLE | 1061554 | 2 | 2 | 2 |
| 12 | PIN | 1062149 | 2 | 2 | 2 |
| 13 | BOLT | 1062140 | 2 | 2 | 2 |
| 14 | WASHER | 05.281.14 | 6 | 6 | 6 |
| 15 | NUT | 1062108 | 2 | 2 | 2 |
| 16 | BOLT | 1061687 | 2 | 2 | 2 |
| 17 | WASHER | 05.282.08 | 2 | 2 | 2 |
| 18 | BUSHING | 1061337 | 2 | 2 | 2 |

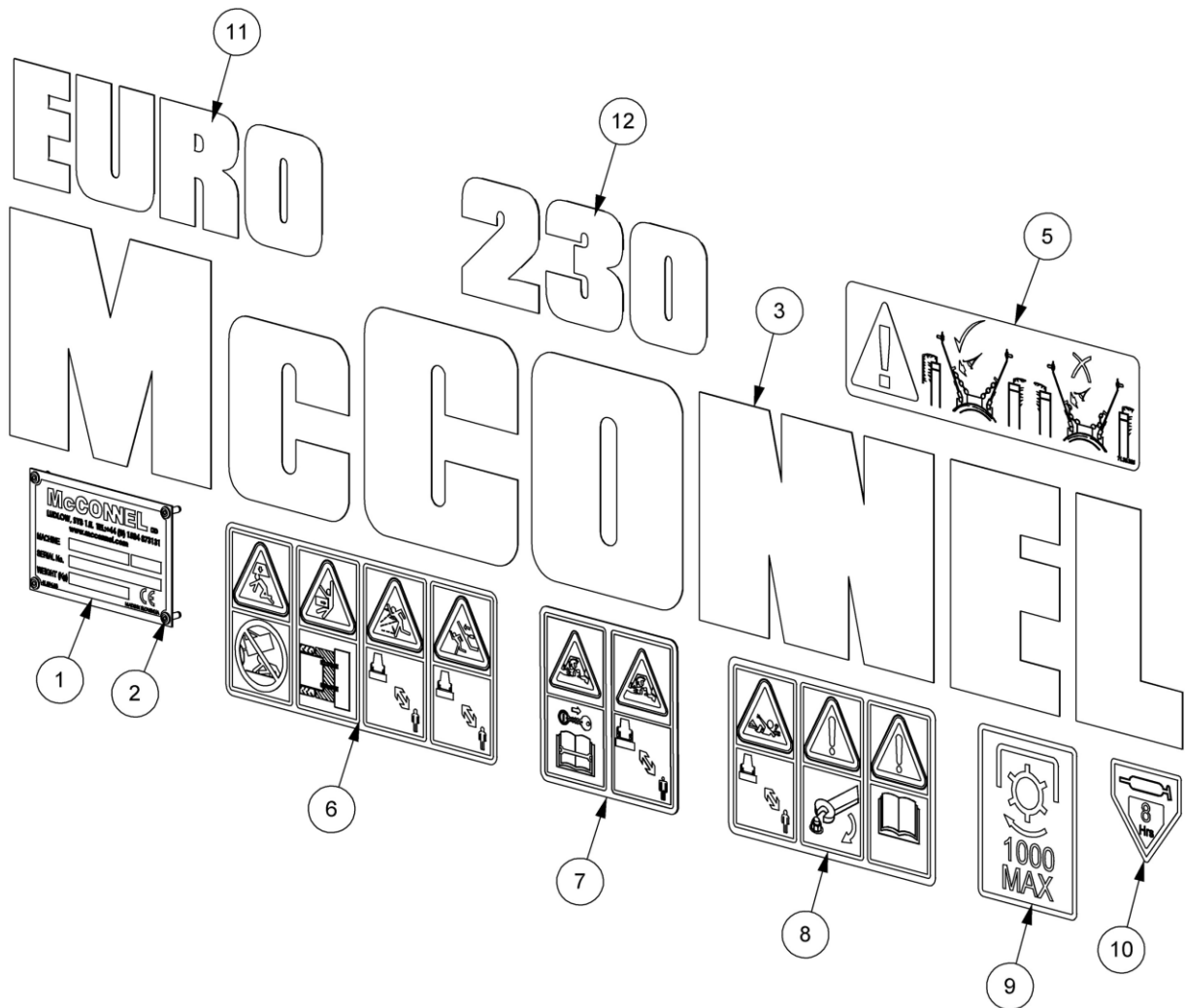

| REF. | QTY. | PART No. | DESCRIPTION |
|------|------|----------------|------------------------------------|
| | | 1061710 | DECAL KIT - MAGNUM 230 EURO |
| 1 | 1 | 41.094.03 | SERIAL NUMBER PLATE |
| 2 | 4 | 7103230 | POP RIVET |
| 3 | 1 | 1290527 | DECAL - McCONNEL (BLACK) |
| 4 | 1 | 1290558 | DECAL - MAGNUM (BLACK) |
| 5 | 1 | 7135295 | DECAL - TIGHTEN CHECK CHAINS |
| 6 | 1 | 09.821.29 | DECAL - COMBINED EURODECAL |
| 7 | 1 | 09.821.31 | DECAL - COMBINED EURODECAL |
| 8 | 1 | 09.821.34 | DECAL - COMBINED EURODECAL |
| 9 | 1 | 09.811.02 | DECAL - 1000 MAX (CW) |
| 10 | 4 | 09.810.01 | DECAL - GREASE 8 HRS |
| 11 | 1 | 1290730 | DECAL - EURO |
| 12 | 1 | 1290727 | DECAL - 230 |

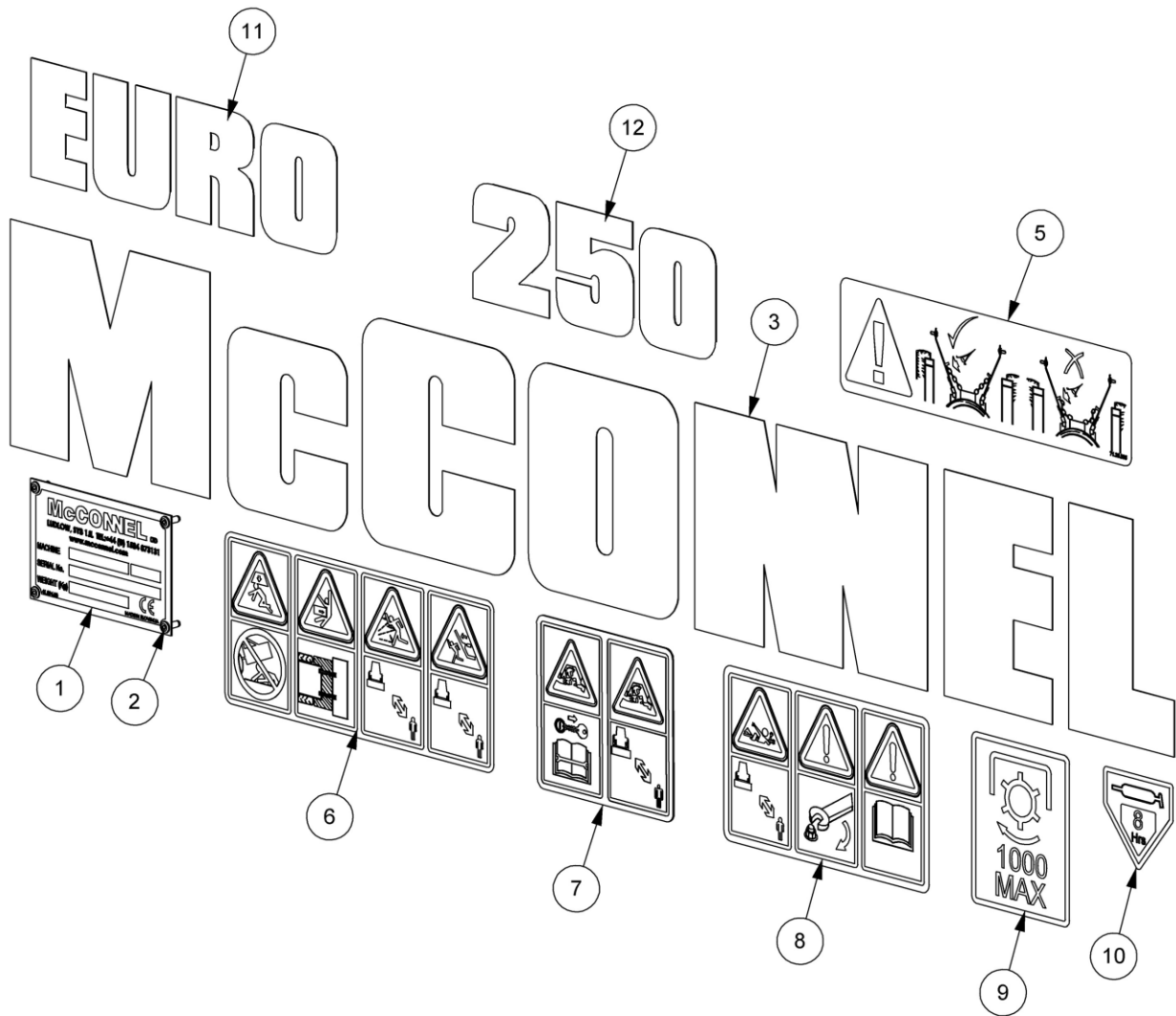

| REF. | QTY. | PART No. | DESCRIPTION |
|------|------|----------------|------------------------------------|
| | | 1061711 | DECAL KIT - MAGNUM 250 EURO |
| 1 | 1 | 41.094.03 | SERIAL NUMBER PLATE |
| 2 | 4 | 7103230 | POP RIVET |
| 3 | 1 | 1290527 | DECAL - McCONNEL (BLACK) |
| 4 | 1 | 1290558 | DECAL - MAGNUM (BLACK) |
| 5 | 1 | 7135295 | DECAL - TIGHTEN CHECK CHAINS |
| 6 | 1 | 09.821.29 | DECAL - COMBINED EURODECAL |
| 7 | 1 | 09.821.31 | DECAL - COMBINED EURODECAL |
| 8 | 1 | 09.821.34 | DECAL - COMBINED EURODECAL |
| 9 | 1 | 09.811.02 | DECAL - 1000 MAX (CW) |
| 10 | 4 | 09.810.01 | DECAL - GREASE 8 HRS |
| 11 | 1 | 1290730 | DECAL - EURO |
| 12 | 1 | 1290728 | DECAL - 250 |

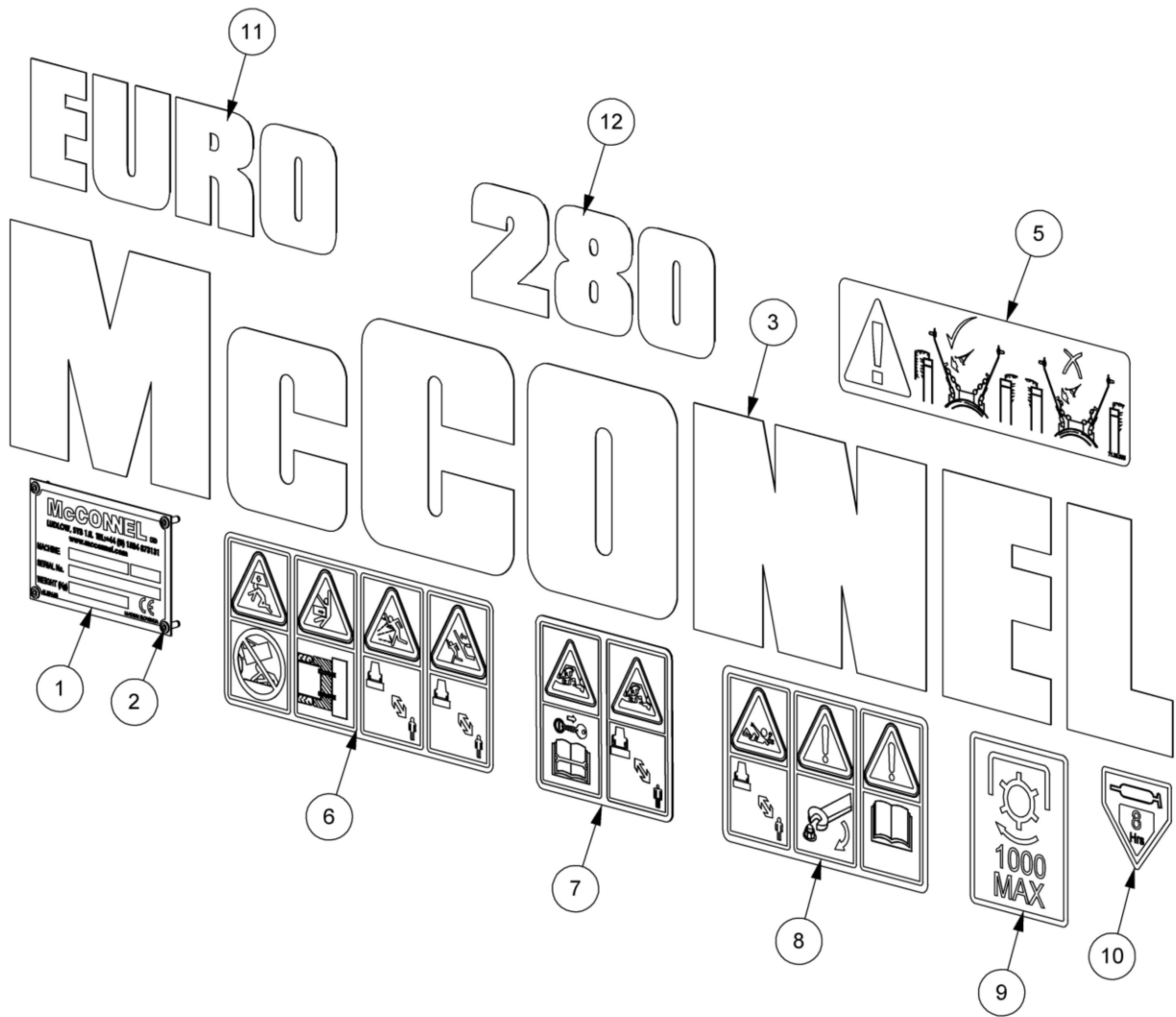

| REF. | QTY. | PART No. | DESCRIPTION |
|------|------|----------------|------------------------------------|
| | | 1061712 | DECAL KIT - MAGNUM 280 EURO |
| 1 | 1 | 41.094.03 | SERIAL NUMBER PLATE |
| 2 | 4 | 7103230 | POP RIVET |
| 3 | 1 | 1290527 | DECAL - McCONNEL (BLACK) |
| 4 | 1 | 1290558 | DECAL - MAGNUM (BLACK) |
| 5 | 1 | 7135295 | DECAL - TIGHTEN CHECK CHAINS |
| 6 | 1 | 09.821.29 | DECAL - COMBINED EURODECAL |
| 7 | 1 | 09.821.31 | DECAL - COMBINED EURODECAL |
| 8 | 1 | 09.821.34 | DECAL - COMBINED EURODECAL |
| 9 | 1 | 09.811.02 | DECAL - 1000 MAX (CW) |
| 10 | 4 | 09.810.01 | DECAL - GREASE 8 HRS |
| 11 | 1 | 1290730 | DECAL - EURO |
| 12 | 1 | 1290729 | DECAL - 280 |



McConnel Limited, Temeside Works, Ludlow, Shropshire SY8 1JL. England.
Telephone: 01584 873131. Facsimile: 01584 876463. www.mcconnel.com