

Publication: 745
June 2013
Part No. 22675.45
Revised: 28.08.14

MAGNUM ELITE OFFSET FLAIL MOWER/SHREDDER

Models 160, 190 & 225
Builds 2013-2014



For machines prior to S/N: M1538189

Operation & Parts Manual



IMPORTANT VERIFICATION OF WARRANTY REGISTRATION



DEALER WARRANTY INFORMATION & REGISTRATION VERIFICATION

It is imperative that the selling dealer registers this machine with McConnel Limited before delivery to the end user – failure to do so may affect the validity of the machine warranty.

To register machines go to the McConnel Limited web site at www.mcconnel.com, log onto 'Dealer Inside' and select the 'Machine Registration button' which can be found in the Service Section of the site. Confirm to the customer that the machine has been registered in the section below.

Should you experience any problems registering a machine in this manner please contact the McConnel Service Department on 01584 875848.

Registration Verification

Dealer Name:
Dealer Address:
Customer Name:
Date of Warranty Registration:/...../..... Dealer Signature:

NOTE TO CUSTOMER / OWNER

Please ensure that the above section above has been completed and signed by the selling dealer to verify that your machine has been registered with McConnel Limited.

IMPORTANT: During the initial 'bedding in' period of a new machine it is the customer's responsibility to regularly inspect all nuts, bolts and hose connections for tightness and re-tighten if required. New hydraulic connections occasionally weep small amounts of oil as the seals and joints settle in – where this occurs it can be cured by re-tightening the connection – *refer to torque settings chart below*. The tasks stated above should be performed on an hourly basis during the first day of work and at least daily thereafter as part of the machines general maintenance procedure.

TORQUE SETTINGS FOR HYDRAULIC FITTINGS

HYDRAULIC HOSE ENDS		
BSP	Setting	Metric
1/4"	18 Nm	19 mm
3/8"	31 Nm	22 mm
1/2"	49 Nm	27 mm
5/8"	60 Nm	30 mm
3/4"	80 Nm	32 mm
1"	125 Nm	41 mm
1.1/4"	190 Nm	50 mm
1.1/2"	250 Nm	55 mm
2"	420 Nm	70 mm

PORT ADAPTORS WITH BONDED SEALS		
BSP	Setting	Metric
1/4"	34 Nm	19 mm
3/8"	47 Nm	22 mm
1/2"	102 Nm	27 mm
5/8"	122 Nm	30 mm
3/4"	149 Nm	32 mm
1"	203 Nm	41 mm
1.1/4"	305 Nm	50 mm
1.1/2"	305 Nm	55 mm
2"	400 Nm	70 mm

WARRANTY POLICY

WARRANTY REGISTRATION

All machines must be registered, by the selling dealer with McConnel Ltd, before delivery to the end user. On receipt of the goods it is the buyer's responsibility to check that the Verification of Warranty Registration in the Operator's Manual has been completed by the selling dealer.

1. LIMITED WARRANTIES

- 1.01. *All machines supplied by McConnel Ltd are warranted to be free from defects in material and workmanship from the date of sale to the original purchaser for a period of 12 months, unless a different period is specified.*
- 1.02. *All spare parts supplied by McConnel Ltd and purchased by the end user are warranted to be free from defects in material and workmanship from the date of sale to the original purchaser for a period of 6 months. All parts warranty claims must be supported by a copy of the failed part invoice to the end user. We cannot consider claims for which sales invoices are not available.*
- 1.03. *The warranty offered by McConnel Ltd is limited to the making good by repair or replacement for the purchaser any part or parts found, upon examination at its factory, to be defective under normal use and service due to defects in material or workmanship. Returned parts must be complete and unexamined. Pack the component(s) carefully so that any transit damage is avoided. All ports on hydraulic items should be drained of oil and securely plugged to prevent seepage and foreign body ingress. Certain other components, electrical items for example, may require particular care when packing to avoid damage in transit.*
- 1.04. *This warranty does not extend to any product from which McConnel Ltd's serial number plate has been removed or altered.*
- 1.05. *This warranty does not apply to any part of the goods, which has been subjected to improper or abnormal use, negligence, alteration, modification, fitment of non-genuine parts, accident damage, or damage resulting from contact with overhead power lines, damage caused by foreign objects (e.g. stones, iron, material other than vegetation), failure due to lack of maintenance, use of incorrect oil or lubricants, contamination of the oil, or which has served its normal life. This warranty does not apply to any expendable items such as blades, belts, clutch linings, filter elements, flails, flap kits, skids, soil engaging parts, shields, guards, wear pads, pneumatic tyres or tracks.*
- 1.06. *Temporary repairs and consequential loss - i.e. oil, downtime and associated parts are specifically excluded from the warranty.*
- 1.07. *Warranty on hoses is limited to 12 months and does not include hoses which have suffered external damage. Only complete hoses may be returned under warranty, any which have been cut or repaired will be rejected.*
- 1.08. *Machines must be repaired immediately a problem arises. Continued use of the machine after a problem has occurred can result in further component failures, for which McConnel Ltd cannot be held liable, and may have safety implications.*
- 1.09. *If in exceptional circumstances a non McConnel Ltd part is used to effect a repair, warranty reimbursement will be at no more than McConnel Ltd's standard dealer cost for the genuine part.*
- 1.10. *Except as provided herein, no employee, agent, dealer or other person is authorised to give any warranties of any nature on behalf of McConnel Ltd.*
- 1.11. *For machine warranty periods in excess of 12 months the following additional exclusions shall apply:*
 - 1.11.1. *Hoses, exposed pipes and hydraulic tank breathers.*
 - 1.11.2. *Filters.*
 - 1.11.3. *Rubber mountings.*
 - 1.11.4. *External electric wiring.*
 - 1.11.5. *Bearings and seals.*

- 1.12. All service work, particularly filter changes, must be carried out in accordance with the manufacturer's service schedule. Failure to comply will invalidate the warranty. In the event of a claim, proof of the service work being carried out may be required.
- 1.13. Repeat or additional repairs resulting from incorrect diagnosis or poor quality previous repair work are excluded from warranty.

NB Warranty cover will be invalid if any non-genuine parts have been fitted or used. Use of non-genuine parts may seriously affect the machine's performance and safety. McConnell Ltd cannot be held responsible for any failures or safety implications that arise due to the use of non-genuine parts.

2. REMEDIES AND PROCEDURES

- 2.01. The warranty is not effective unless the Selling Dealer registers the machine, via the McConnell Ltd web site and confirms the registration to the purchaser by completing the confirmation form in the operator's manual.
- 2.02. Any fault must be reported to an authorised McConnell Ltd dealer as soon as it occurs. Continued use of a machine, after a fault has occurred, can result in further component failure for which McConnell Ltd cannot be held liable.
- 2.03. Repairs should be undertaken within two days of the failure. Claims submitted for repairs undertaken more than 2 weeks after a failure has occurred, or 2 days after the parts were supplied will be rejected, unless the delay has been authorised by McConnell Ltd. Please note that failure by the customer to release the machine for repair will not be accepted as a reason for delay in repair or submitting warranty claims.
- 2.04. All claims must be submitted, by an authorised McConnell Ltd Service Dealer, within 30 days of the date of repair.
- 2.05. Following examination of the claim and parts, McConnell Ltd will pay, at their discretion, for any valid claim the invoiced cost of any parts supplied by McConnell Ltd and appropriate labour and mileage allowances if applicable.
- 2.06. The submission of a claim is not a guarantee of payment.
- 2.07. Any decision reached by McConnell Ltd is final.

3. LIMITATION OF LIABILITY

- 3.01. McConnell Ltd disclaims any express (except as set forth herein) and implied warranties with respect to the goods including, but not limited to, merchantability and fitness for a particular purpose.
- 3.02. McConnell Ltd makes no warranty as to the design, capability, capacity or suitability for use of the goods.
- 3.03. Except as provided herein, McConnell Ltd shall have no liability or responsibility to the purchaser or any other person or entity with respect to any liability, loss, or damage caused or alleged to be caused directly or indirectly by the goods including, but not limited to, any indirect, special, consequential, or incidental damages resulting from the use or operation of the goods or any breach of this warranty. Notwithstanding the above limitations and warranties, the manufacturer's liability hereunder for damages incurred by the purchaser or others shall not exceed the price of the goods.
- 3.04. No action arising out of any claimed breach of this warranty or transactions under this warranty may be brought more than one (1) year after the cause of the action has occurred.

4. MISCELLANEOUS

- 4.01. McConnell Ltd may waive compliance with any of the terms of this limited warranty, but no waiver of any terms shall be deemed to be a waiver of any other term.
- 4.02. If any provision of this limited warranty shall violate any applicable law and is held to be unenforceable, then the invalidity of such provision shall not invalidate any other provisions herein.
- 4.03. Applicable law may provide rights and benefits to the purchaser in addition to those provided herein.



DECLARATION OF CONFORMITY

Conforming to EU Machinery Directive 2006/42/EC

We,

McCONNEL LIMITED, Temeside Works, Ludlow, Shropshire SY8 1JL, UK

Hereby declare that:

The Product; Tractor Mounted Flail Mower

Product Code; MA16, MA19, MA22

Serial No. & Date Type

Manufactured in; Slovenija

Complies with the required provisions of the Machinery Directive 2006/42/EC
The machinery directive is supported by the following harmonized standards;

- BS EN ISO 14121-1 (2007) Safety of machinery - Risk assessment, Part 1: Principles Part 2: practical guide and examples of methods.
- BS EN ISO 12100-1 (2010) Safety of machinery - Part 1: Basic terminology and methodology Part 2: Technical principles.
- BS EN 349(1993)+ A1 (2008) Safety of machinery - Minimum distances to avoid the entrapment with human body parts.
- BS EN 953 (1998) Safety of machinery - Guards General requirements for the design and construction of fixed and movable guards.
- BS EN 982(1996)+ A1 (2008) Safety requirements for fluid power systems and their components. Hydraulics

McCONNEL LIMITED operates an ISO 9001:2008 quality management system, certificate number: FM25970.

This system is continually assessed by the;
British Standards Institution (BSI), Beech House, Milton Keynes, MK14 6ES, UK
BSI is accredited by UK Accreditation Service, accreditation number: UKAS 003.
The EC declaration only applies if the machine stated above is used in accordance with the operating instructions.

Signed *Responsible Person*
CHRISTIAN DAVIES on behalf of McCONNEL LIMITED

Status: General Manager

Date: May 2011

FLAIL MOWER INSPECTION AND MAINTENANCE

A daily equipment inspection of the tractor and mower should be conducted before the equipment is used. You may use the inspection sheets to assist with these daily inspections. Any damaged or missing guards should be repaired or replaced before operating the mower. Failure to repair the damaged shield can result in objects being thrown from the mower and possibly hitting the operator or bystander.

Inspect the Mower for Safe Operating Condition

- Make sure the driveline guards and shielding are in place and in good repair.
- Inspect the chain guards, flexible and/or solid deflector thrown object shielding to assure that they are in place on the front and rear of the mower deck and in good repair. Repair or replace any damaged or missing thrown object shields.
- Ensure the mower cutting height is set high enough to reduce the possibility of the mower blades contacting the ground. Actual height will be dependent on the ground conditions. Increase the height when working in rough or undulating conditions.
- Inspect for broken, chipped, bent, missing, or severely worn blades. Replace damaged blades before operating the mower. Ensure the blade retaining bolts and fasteners are secure and tight.
- Lubricate the driveline universal joints and telescoping members daily.
- Inspect the wheel lug bolt/nuts to assure that they are tight.
- If mower is equipped with pneumatic tires, make sure they have the required air pressure.
- Inspect for worn or damaged decals and safety instructions. Replace unreadable, damaged or missing safety decals.
- Follow the operator's manual(s) inspection and maintenance instructions for lubricating parts, and keeping thrown object shielding, driveline guards, rotating parts shields, mower blades and decals in good repair.

Inspect the Tractor for Safe Operating Condition:

- Inspect the controls, lights, SMVs (Slow Moving Vehicle sign), seat belts, and ROPS to assure that they are in place and in good working order.
- Be sure the tires, wheels, lug bolts/nuts are in good condition.
- Make sure the tractor brakes and steering are in proper operating condition.
- Follow the operator's manual(s) inspection and maintenance procedures for keeping the tractor in good and safe condition before operating.

The inspection sheet on the following page should be kept in this book as a record. A second sheet is included for you to cut out and photocopy or the inspection sheets can be downloaded from our website at;

<http://www.mcconnel.com/support/aftersales/default.aspx?nav=After Sales>



FLAIL MOWERS PRE-OPERATION Inspection

Mower ID _____ Date: _____ Shift: _____

WARNING



Before conducting the inspection, make sure the tractor engine is off, with the key removed, all rotation has stopped and the tractor is in park with the parking brake engaged. Make sure the mower is resting on the ground or is securely blocked up and supported and all hydraulic pressure has been relieved.

Item	Condition at start of shift	Specific Comments if not O.K.
The Operator's Manual is in the Canister on the mower		
All Warning Decals are in place, clean and legible		
The Hyd. Cylinder pins are tight and correctly secured		
The Hyd Cylinder hose connections are tight		
There are no oil leaks		
There are no damaged hoses		
Flails are not missing chipped, broken or excessively worn		
The Flail bolts are tight		
The Front & Rear Flaps are fitted and in good condition		
The Skid shoes are in good condition & tight		
The Rotor Bearings are in good condition and greased		
The Roller bearings are in good condition and greased		
There are no cracks or holes in flail casing		
The drive line/gearbox shaft guard is in good condition		
The drive line/gearbox shaft guard is correctly secured		
Driveline telescoping members & u-joints are lubricated		
Driveline yokes are securely attached to tractor & mower		
All linkage mounting pins are securely fastened		

Operators Signature: _____

DO NOT OPERATE an UNSAFE TRACTOR or MOWER



TRACTOR PRE-OPERATION Inspection

Power Arm ID _____ Date: _____ Shift: _____

WARNING



Before conducting the inspection, make sure the tractor engine is off, the key is removed all rotation has stopped and the tractor is in park with the parking brake engaged. Any implement attached to the tractor is firmly on the ground.

Item	Condition at start of shift	Specific Comments if not O.K.
The flashing lights function properly.		
All lights are clean and working correctly		
All cab windows are clean and wipers working correctly		
The SMV sign, where required, is clean and visible.		
The tyres are in good condition with correct pressure.		
The wheel nuts are tight.		
The tractor brakes are in good condition.		
The steering linkage is in good condition.		
There are no visible oil leaks.		
The hydraulic controls function properly.		
The ROPS or ROPS cab is in good condition.		
The seatbelt is in place and in good condition.		
The 3-point hitch is in good condition.		
The drawbar/pick up hook is secure & in good condition		
The PTO master shield is in place.		
The engine oil level is full.		
The brake fluid level is full.		
The power steering fluid level is full.		
The fuel level is adequate.		
The engine coolant fluid level is full.		
The radiator & oil cooler are free of debris.		
The air filter is in good condition		

Operators Signature: _____

DO NOT OPERATE an UNSAFE TRACTOR or MOWER



FLAIL MOWERS PRE-OPERATION Inspection

Mower ID _____ Date: _____ Shift: _____

WARNING



Before conducting the inspection, make sure the tractor engine is off, with the key removed, all rotation has stopped and the tractor is in park with the parking brake engaged. Make sure the mower is resting on the ground or is securely blocked up and supported and all hydraulic pressure has been relieved.

Item	Condition at start of shift	Specific Comments if not O.K.
The Operator's Manual is in the Canister on the mower		
All Warning Decals are in place, clean and legible		
The Hyd. Cylinder pins are tight and correctly secured		
The Hyd Cylinder hose connections are tight		
There are no oil leaks		
There are no damaged hoses		
Flails are not missing chipped, broken or excessively worn		
The Flail bolts are tight		
The Front & Rear Flaps are fitted and in good condition		
The Skid shoes are in good condition & tight		
The Rotor Bearings are in good condition and greased		
The Roller bearings are in good condition and greased		
There are no cracks or holes in flail casing		
The drive line/gearbox shaft guard is in good condition		
The drive line/gearbox shaft guard is correctly secured		
Driveline telescoping members & u-joints are lubricated		
Driveline yokes are securely attached to tractor & mower		
All linkage mounting pins are securely fastened		

Operators Signature: _____

DO NOT OPERATE an UNSAFE TRACTOR or MOWER



TRACTOR PRE-OPERATION Inspection

Power Arm ID _____ Date: _____ Shift: _____

WARNING



Before conducting the inspection, make sure the tractor engine is off, the key is removed all rotation has stopped and the tractor is in park with the parking brake engaged. Any implement attached to the tractor is firmly on the ground.

Item	Condition at start of shift	Specific Comments if not O.K.
The flashing lights function properly.		
All lights are clean and working correctly		
All cab windows are clean and wipers working correctly		
The SMV sign, where required, is clean and visible.		
The tyres are in good condition with correct pressure.		
The wheel nuts are tight.		
The tractor brakes are in good condition.		
The steering linkage is in good condition.		
There are no visible oil leaks.		
The hydraulic controls function properly.		
The ROPS or ROPS cab is in good condition.		
The seatbelt is in place and in good condition.		
The 3-point hitch is in good condition.		
The drawbar/pick up hook is secure & in good condition		
The PTO master shield is in place.		
The engine oil level is full.		
The brake fluid level is full.		
The power steering fluid level is full.		
The fuel level is adequate.		
The engine coolant fluid level is full.		
The radiator & oil cooler are free of debris.		
The air filter is in good condition		

Operators Signature: _____

DO NOT OPERATE an UNSAFE TRACTOR or MOWER

LIST OF CONTENTS

Operator Section

General Information	1
Machine Description & Purpose Of Use	2
Machine Identification	2
Component Identification	2
Technical Specifications	3
Safety Information	4
Safety Decals	5
Protection Features	6
Handling The Machine	6
Tractor Preparation	7
Machine Attachment	8
PTO Shaft	9
Setup & Adjustment	10
Pre-Operational Checks	10
Operation	11
Transport	13
Drive Belts	14
Flails	15
Maintenance	16
Troubleshooting	19

Parts Section

Mower Assembly	21
----------------	----

GENERAL INFORMATION

Always read this manual before fitting or operating the machine – whenever any doubt exists contact your dealer or the McConnel Service Department for advice and assistance.

Use only McConnel Genuine Service Parts on McConnel Equipment and Machines

DEFINITIONS – The following definitions apply throughout this manual:

WARNING

An operating procedure, technique etc., which –
can result in personal injury or loss of life if not observed carefully.

CAUTION

An operating procedure, technique etc., which –
can result in damage to either machine or equipment if not observed carefully.

NOTE

An operating procedure, technique etc., which –
is considered essential to emphasis.

LEFT AND RIGHT HAND

This term is applicable to the machine when attached to the tractor and is viewed
from the rear – this also applies to tractor references.

MACHINE & DEALER INFORMATION

Record the Serial Number of your machine on this page and always quote this number when ordering parts. Whenever information concerning the machine is requested remember also to state the make and model of tractor to which the machine is fitted.

Machine Serial Number:	Installation Date:
Machine Model details:	
Dealer Name:	
Dealer Address:	
Dealer Telephone No:	
Dealer Email Address:	

MACHINE DESCRIPTION & PURPOSE OF USE

The Magnum Elite Offset series of machines are '3-point linkage' tractor mounted universal flail mower/shredders designed primarily for the mulching of grasses, brambles, small bushes, branches, vines, and general crop residues. Their tough construction, adjustable working position and ability to work at any angle of between +90° and - 65° makes them the ideal machine for maintenance use in difficult to access green areas as well as general use in vineyards, orchards, on verges and in scrubland. Available in working widths of 1.6, 1.9 & 2.25m with breakback protection on all models they are suitable for use by farmers and contractors alike.

These machines should only be used to perform tasks for which they were designed – use of the machine for any other function may be both dangerous to persons and damaging to components and is therefore not advisable.

MACHINE IDENTIFICATION

Each machine is fitted with an identification plate with the following information:

1. Machine (Part Number)
2. Machine Serial No.
3. Machine Weight

When ordering spares or replacement parts from your local dealer it is important to quote both Part Number and Serial Number as stated on the identification plate so the machine and model can be quickly and correctly identified.



COMPONENT IDENTIFICATION

Components

1. Main Frame
2. Gearbox
3. Belt Drive
4. 3-Point Linkage
5. Rear Roller
6. Support Foot
7. Skid
8. Hydraulic Rams
9. Mower Arm

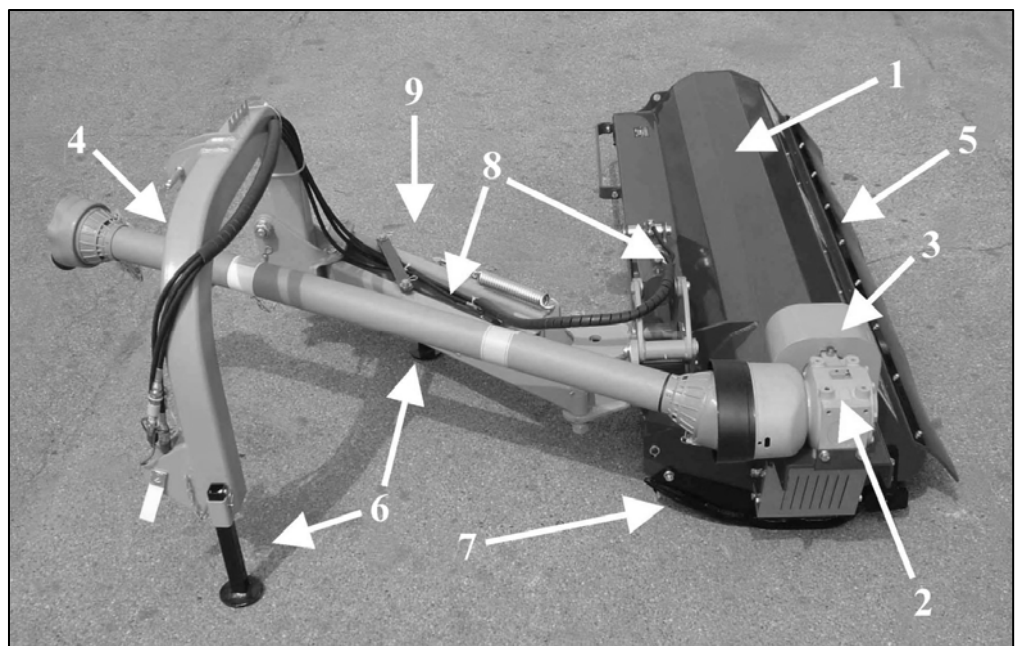

TECHNICAL SPECIFICATIONS

SPECIFICATION	160 Model	190 Model	225 Model
Working Width	156cm	186cm	220cm
Tractor Power Requirement (kW/KM)	50/80	70/90	80/100
Minimum Tractor Weight	2200kg	2400kg	2600kg
Minimum Tractor Width	180cm	200cm	200cm
Linkage	Cat. II, III	Cat. II, III	Cat. II, III
PTO Speed	540RPM	540RPM	540RPM
Machine Weight	653kg	755kg	777kg
Machine Width	210cm	240cm	275cm
Machine Height	100cm	100cm	100cm
Machine Length	210cm	210cm	210cm
Machine Transport Length	165cm	165cm	165cm
No. Cutting Blades (Hammer type)	20	24	28
No. Cutting Blades (Y-Blade type)	40	48	56
Working Angle Capability	+90°/-65°	+90°/-65°	+90°/-65°

MACHINE POSITION	160 Model	190 Model	225 Model
A	160cm	190cm	225cm
B	200cm	200cm	200cm
C	34cm	34cm	34cm
D	274cm	304cm	339cm
E	-	190cm	225cm

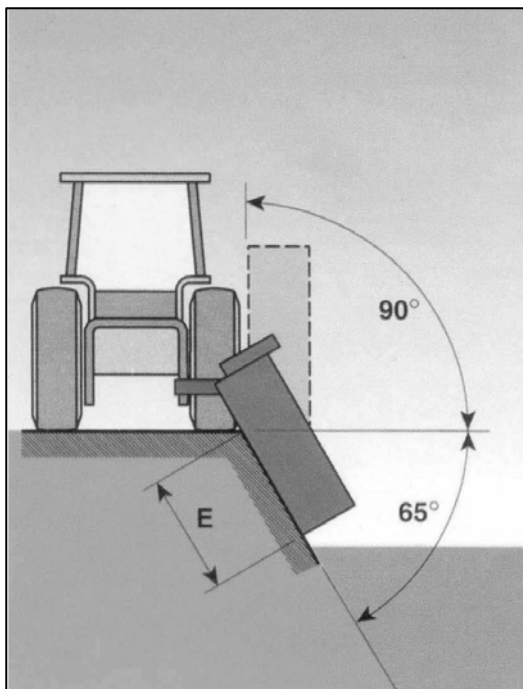

Working Angles from +90° to -65°

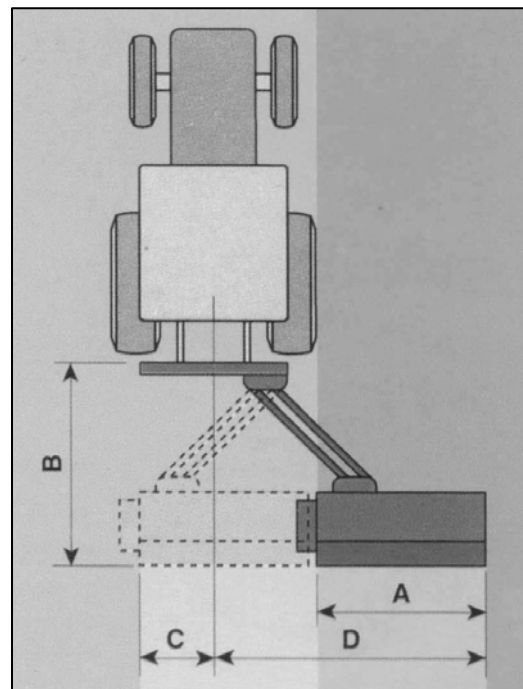

Positional Working Widths (see above)

OPTIONAL EQUIPMENT

The standard flails fitted to the machine are the hammer blade type; Y-blade flails are optional. The cutting capability of the each particular type of flail will be dependant on the sort and hardness of the material being cut, but in general the following cutting thicknesses apply:

Y-blade flails – for materials up to a maximum of 30mm diameter.

Hammer flails – for materials up to a maximum of 50mm diameter.

SAFETY INFORMATION

General safety rules:

- ▲ Always read and follow the instructions for the use and maintenance of the machine before carrying out any work operations or servicing tasks.
- ▲ Improper use of the machine is both highly dangerous to persons and damaging to the machine components – only use the machine for its designated task.
- ▲ Both operators and the maintenance fitters should be familiar with the machine and fully aware of dangers surrounding improper use or incorrect repairs.
- ▲ Before starting, checks to both tractor and machine must be carried out as regards: functionality, road safety, accident prevention rules.
- ▲ Even when using the machine correctly, stones or other objects may be thrown a long distance. Therefore nobody must stand within the danger area. Special attention must be paid when working near roads or buildings.
- ▲ Use tractor's fitted with safety cabs.
- ▲ The condition of flails and of machine guards must be checked before beginning the daily work - they must be replaced if damaged or missing before you use the machine.
- ▲ During checks or repairs, make sure nobody could start the machine by mistake.
- ▲ Never wear loose or fluttering clothes.
- ▲ Never carry passengers on the tractor.
- ▲ Never carry passengers on the machine.
- ▲ Never connect the power takeoff with the engine running.
- ▲ Never approach the machine until the rotor has completely stopped.
- ▲ Do not enter the working zone of the PTO shaft. It is dangerous to approach the rotating parts of a machine.
- ▲ Keep the PTO shaft guard in good condition.
- ▲ Before starting, check the surrounding area for the likely presence of children and/or animals.
- ▲ Do not stand near the machine when it is operating.
- ▲ The PTO shaft must be assembled and disassembled only with the engine stopped and the starting key removed.
- ▲ Before connecting the power takeoff, check that the speed and the rotational direction correspond to those of the machine.
- ▲ Immediately replace missing or damaged safety decals.
- ▲ Before leaving the tractor with the machine attached, proceed as follows:
 1. Disconnect the power takeoff,
 2. Put the machine steadily on the ground using the tractor's hydraulic lift.
 3. Apply the hand brake and, if the ground is steeply sloping, wedge the tractor.
 4. Remove the starting key.

Transportation Safety

- ▲ In transport, reduce speed, especially on bumpy roads, the weight of the machine may render driving difficult and damage the machine itself.
- ▲ Ensure the levers that operate the hydraulic lift are locked, to avoid the lowering of the machine during transport.
- ▲ When driving on public roads, respect all road rules in force.
- ▲ Never transport the machine with the rotor running, even for short distances.

Operating Safety

- ▲ Pay special attention when working with the machine not to touch fixed objects such as road drain, walls, shafts, kerbs, guard rails, tracks etc. This could cause the breakage of the flails, which would be thrown out of the machine at very high speed.
- ▲ If wires, ropes or chains should become entangled in the rotor stop immediately to prevent damage or dangerous situations; stop the rotor and the tractor, take out the starting key. Put working gloves on; clear the rotor with the aid of pliers or shears. Do not try to disentangle by inverting the rotational direction of the rotor.
- ▲ Do not use the machine when excessive vibration is experienced, as this may cause breakage and serious damage - find the cause of the vibration and eliminate it before using the machine again.

Although the information given here covers a wide range of safety subjects, it is impossible to predict every eventuality that can occur under differing circumstances whilst operating this machine. No advice given here can replace 'good common sense' and 'total awareness' at all times, but will go a long way towards the safe use of your Twose machine.

SAFETY DECALS

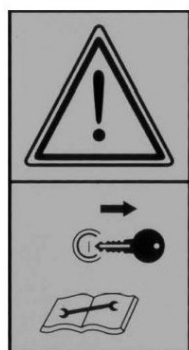

1.

1. Always switch machine off, remove starting key and read instruction manual before performing service or maintenance work on the machine.



2.

2. Keep a safe distance from the machine at all times - risk from projection of objects.



3.

3. Risk of hand injury – always ensure all guard are fitted and in place when machine is operating.



4.

4. Risk of feet injury – keep at a safe distance from the machine when it is operating.



5.

5. Never stand or ride on the machine.

PROTECTION FEATURES

1. PTO Shaft Shield
2. Belt Shield (Upper)
3. Belt Shield (Lower)
4. Warning Decals
5. Side Guard
6. Flaps
7. Horizontal Hydraulic Lock
8. Vertical Hydraulic Lock
9. Frame Guard
10. Mechanical Breakaway
11. Transport Lock
12. Float Mechanism

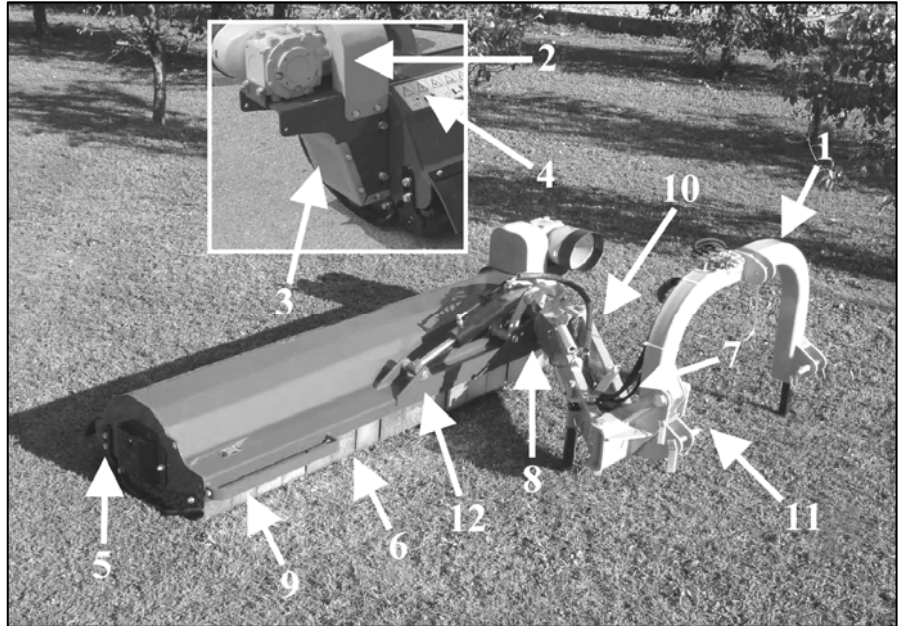

HANDLING THE MACHINE

Care must always be adopted when handling or lifting the machine to avoid personal injury and/or machine damage. Lifting points are located on each side of the machine as shown below. Suitable overhead lifting gear and lifting chains with a minimum SWL in excess of the machines weight should be used. Keep bystanders at a safe distance from the raised machine at all times.

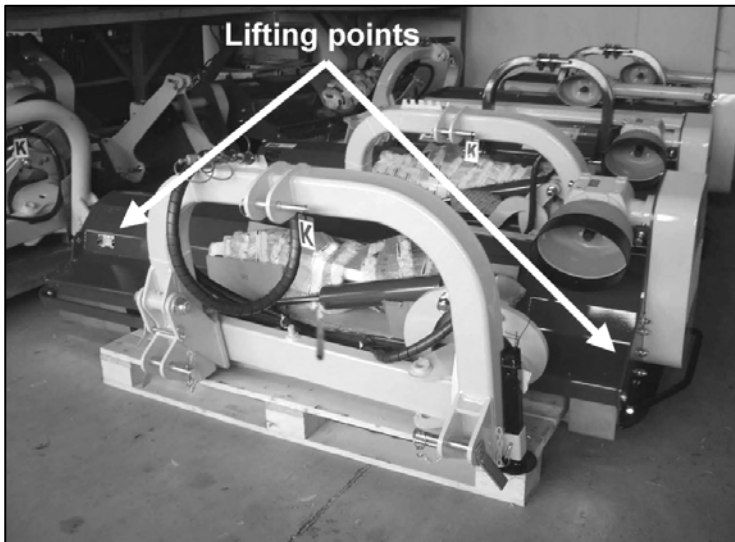

Location of Lifting Points

On delivery of the machine and prior to initial use check all nuts and bolts for tightness, especially those on the blades and arm to frame connection.

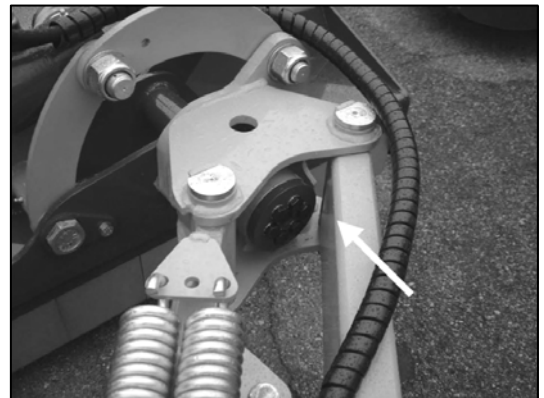

Arm to Frame Connection

VEHICLE / TRACTOR PREPARATION

We recommend vehicles are fitted with cabs using 'safety glass' windows and protective guarding when used with our machines.

Fit Operator Guard (*Part No. 7313324*) using the hooks provided. Shape the mesh to cover all vulnerable areas.

Remember the driver must be looking through mesh and/or polycarbonate

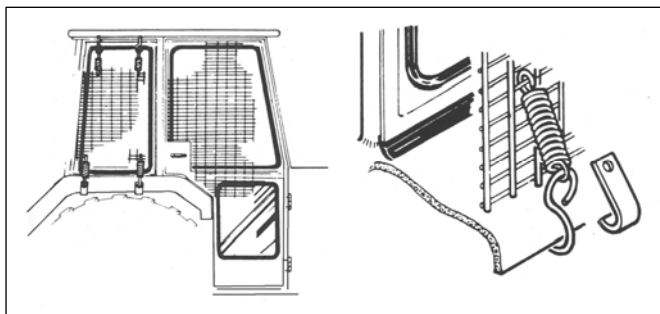

glazing when viewing the machine in all positions - unless the vehicle/ cab manufacturer can demonstrate that the penetration resistance is equivalent to, or higher than, that provided by mesh/polycarbonate glazing. If the tractor has a roll bar only, a frame must be made to carry both mesh and polycarbonate glazing. The operator should also use personal protective equipment to reduce the risk of serious injury such as; eye protection (mesh visor to EN1731 or safety glasses to EN166), hearing protection to EN352, safety helmet to EN297, gloves, filter mask and high visibility clothing.

Vehicle Ballast

It is imperative when attaching 'third-party' equipment to a vehicle that the maximum possible stability of the machine and vehicle combination is achieved – this can be accomplished by the utilisation of 'ballast' in order to counter-balance the additional equipment added.

Front weights may be required for rear mounted machines to place 15% of total outfit weight on the front axle for stable transport on the road and to reduce 'crabbing' due to the drag of the cutting unit when working on the ground.

Where a machine works to the side of the tractor rear weights may be required to maintain a reasonable amount of rear axle load on the opposing wheel.

All factors must be addressed in order to match the type and nature of the equipment added to the circumstances under which it will be used - factors that effect stability are:

- Centre of gravity of the tractor/machine combination.
- Geometric conditions, e.g. position of the cutting head and ballast.
- Weight, track width and wheelbase of the tractor.
- Acceleration, braking, turning and the relative position of the cutting unit during these operations.
- Ground conditions, e.g. slope, grip, load capability of the soil/surface.
- Rigidity of implement mounting.

Suggestions to increase stability:

- Increasing rear wheel track - *a vehicle with a wider wheel track is more stable.*
- Ballasting the wheel; it is preferable to use external weights but liquid can be added to around 75% of the tyre volume – water with anti-freeze or the heavier Calcium Chloride alternative can be used.
- Addition of weights – care should be taken in selecting the location of the weights to ensure they are added to a position that offers the greatest advantage.
- Front axle locking, check with tractor manufacturer.

The advice above is offered as a guide for stability only and is not a guide to vehicle strength. It is therefore recommended that you consult your vehicle manufacturer or local dealer to obtain specific advice on this subject, additionally advice should be sought from a tyre specialist with regard to tyre pressures and ratings suitable for the type and nature of the machine you intend to fit.

ATTACHING THE MACHINE TO THE TRACTOR

Attachment of the machine to the tractor should always be performed on a firm level site.

Attachment to Tractor

Position the tractor's lower linkage at the same height as the machine's lower attachment points.

Remove the lower linkage pins from location 'A' on both sides of the machine. Ensure transport pin 'B' is fitted and secured to lock the arm and linkage in the transport mode – refer to picture opposite ►

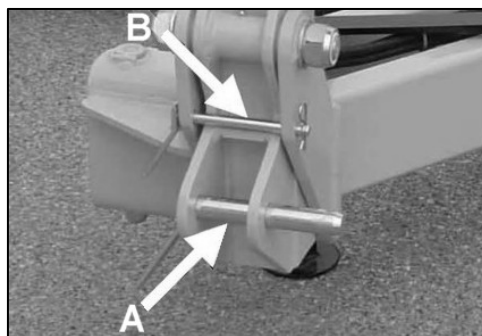

Carefully manoeuvre the tractor squarely to the machine and into its position within the attachment points – fine adjustment of the tractor lower linkage height may be necessary to correctly position the linkage and permit refitting of the linkage pins.

Insert linkage pins at location 'A' and secure in position with locking clips.

Fit top link to upper linkage attachment - indicated 'C' opposite ►

Lift the machine on the tractor's hydraulics and adjust the top link so that the machine is perpendicular to the ground.

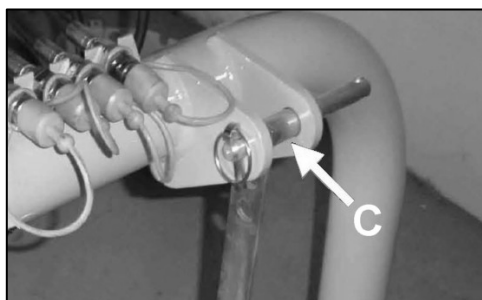

Raise the support legs into the stowed position.

Fit and adjust check chains and/or stabiliser bars to lock the machine into a central position on the tractor.

Connect hoses and test hydraulics to ensure correct operation.

Fit PTO Shaft and attach torque chains to a suitable location – refer to following page for details of PTO measurement and shaft length adjustment.



IMPORTANT! Machines must always be placed into the correct position for transportation; for 160 models this will be horizontal and centrally positioned on the tractor, for 190 & 225 models it will be in the vertical position due to their additional width beyond the tractor.



160 Models are transported horizontally



190 & 225 Models are transported vertically

PTO DRIVESHAFT INSTALLATION

The PTO driveshaft attaches between the tractor and the machine gearbox to transfer the power required to run and operate the machine – it is important to achieve the correct shaft length to avoid risk of it ‘bottoming out’ when raising or lowering the machine.

The procedure for measuring and cutting the shaft is as follows:

Measuring the PTO Shaft

With the machine attached to the tractor in the working position measure the horizontal distance ‘A’ from the tractor’s PTO to the input shaft on the machines gearbox and subtract 75mm (3”) – *this figure is the required shaft length.*

Place the fully closed PTO shaft on the ground and measure its overall length, if the shaft is shorter than the required length you can use it without the need to shorten - *providing it allows for a minimum 150mm (6”) overlap when fitted.*

If the shaft is longer subtract the required shaft length plus an additional 75mm (3”) - *the resulting figure is the excess length that will need to be removed from each half of the shaft.*

Cutting the PTO Shaft

Separate the two halves and using the measurement obtained above shorten both the plastic guarding and the inner steel profile tubes of each shaft by this same amount. De-burr the cut tubes with a file to remove rough or sharp edges and thoroughly clean to remove swarf before greasing, assembling and fitting the shaft.

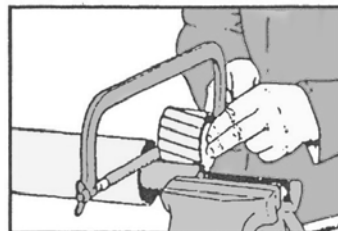
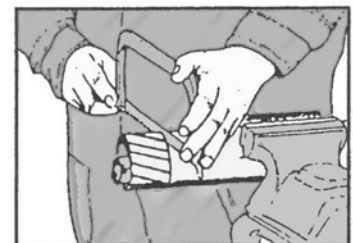
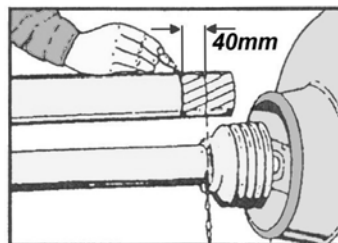
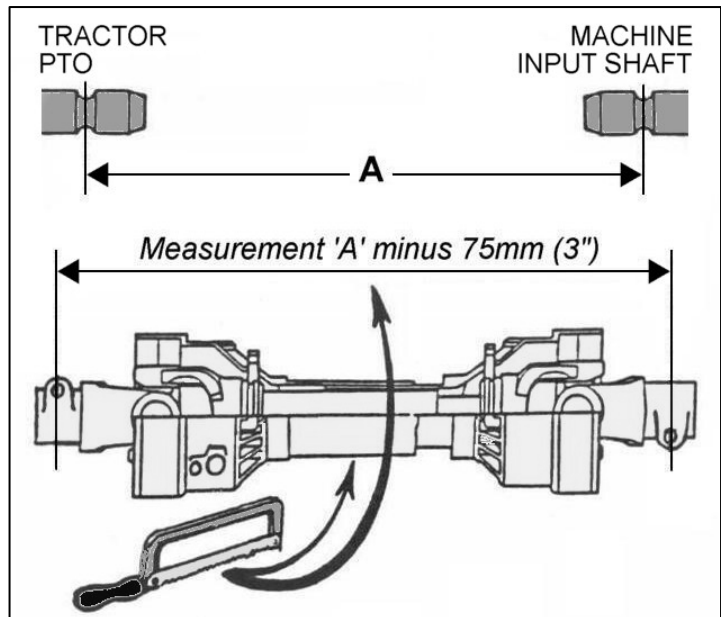

NOTE: For subsequent use with different tractors the shaft should be measured again to check suitability – *there must be a minimum shaft overlap of 150mm (6”).*

Maintenance

To increase the working life of the PTO shaft it should be periodically checked, cleaned and lubricated – *refer to the PTO maintenance section for further details on this subject.*

SETTING UP AND ADJUSTMENT

The height of cut is dependent on working conditions and volume of material. The cutting height can be regulated with the hydraulic system on the tractor and/or rear roller adjustment. The minimum height of cut should be between 1 – 3cm.

NOTE: The machine must always run on the rear roller not the side skids – side skids are a protection feature and in normal working conditions remain clear of the ground. Do not allow the rotor flails to contact the ground - set roller height to allow a minimum flail to ground clearance of 1 to 3cm.

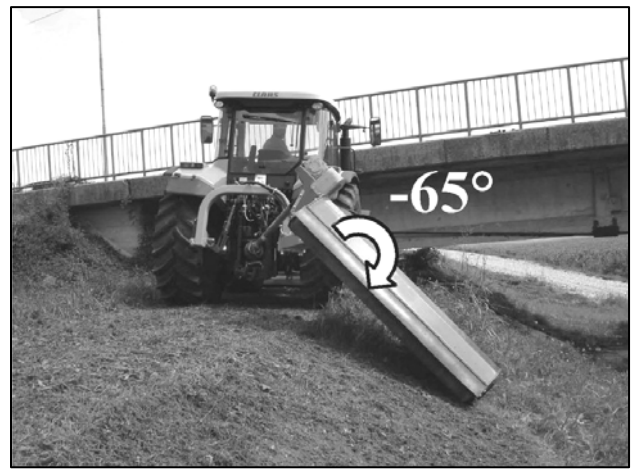
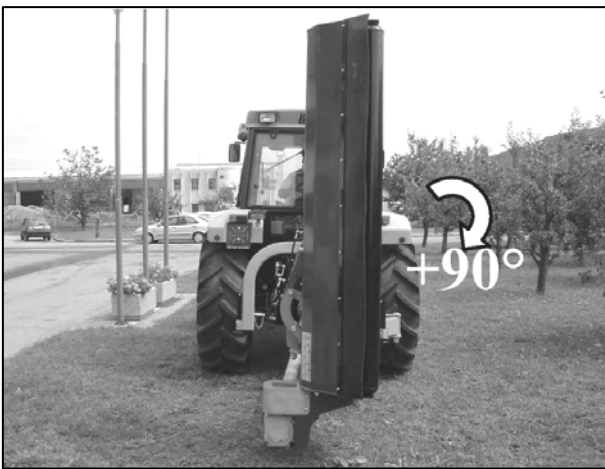
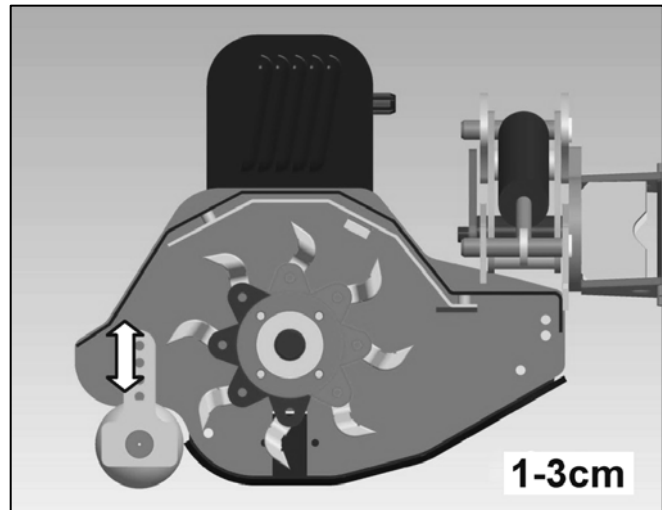

The machines are capable of working at angles from + 90° to - 65°, always ensure when working in the upright position that the machine remains sufficiently clear of the ground, failure to observe this will result in damage to the belt guard. When working in these positions extra care must always be adopted as debris will be ejected outwards or inwards from the machine. Keep persons and animals at a safe distance at all times.

PRE-OPERATIONAL CHECKS

Before commencing work with the machine the following checks should be performed:

- Make a visual inspection of the machine to ensure it is in good operational condition.
- Check all safety guarding is in position and in full working order.
- Check rotor for missing or damaged flails and replace if required.
- Check all greasing points are well lubricated.
- Check gearbox oil level.
- Check belt tension and adjust if required.
- Check PTO speed and direction match that of the machine.

OPERATION

Ensure that the operator is suitably qualified to use a machine of this nature and that they have fully read and understood this manual - they should be aware of all safety aspects relating to the safe use of the machine. It is advisable that all 'first time' operators practice using the machine in a clear safe area prior to work in order to familiarise themselves with its operation.

After the initial first 2 hours of work with a new machine, nuts and bolts should be checked for tightness and the drive belts inspected and re-tensioned if required – refer to belt section for details.

Prior to starting work the area should be checked for dangerous objects such as large stones, wood, wire, glass etc. – hazardous objects should be removed from the area prior to operation with the machine. The location of unmovable or natural hazards should be noted, or if necessary 'marked', to indicate to the operator that the area should either be avoided or additional caution adopted whilst working around the hazard.

Preparing the Machine for Work

Before commencing operation with the machine it must be moved from transport to work mode; models 130, 160 & 190 will already be in the horizontal position but 225 models will first need to be operated to move it from the vertical position into the horizontal.

With the machine horizontal;

Remove the transport locking pin from the lower linkage position ►
- This will allow the mechanical breakback freedom to function.



Place transport pin in stowage location on the machines beam ►



Ensure support legs are in the raised and secured in work position ►

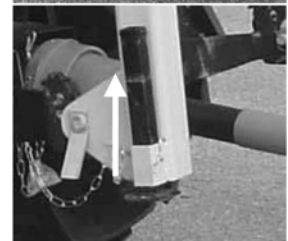

Float Selection

If the terrain of the work area is uneven remove the insert plate from the location indicated to allow float ►

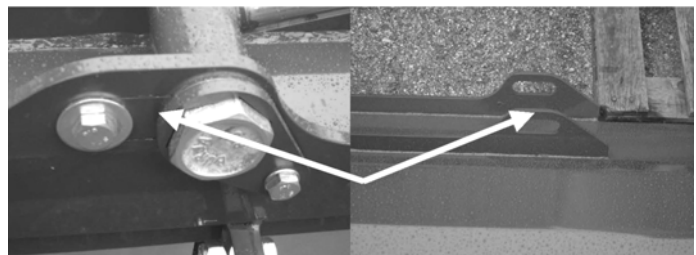

TRANSPORT

The following must be observed at all times when transporting the machine:

- Machine must always be switched off.
- The PTO shaft disconnected.
- Machine must be raised and placed into a central position, 160 models are transported horizontally and 190 & 225 models are transported vertically.
- Transport locks/pins fitted and secured.
- Speed kept to a minimum especially on bumpy roads or terrain.
- Local laws and road regulations respected.
- Awareness of the machines width.

DETACHMENT & STORAGE

Detaching the machine from the tractor

Removal of the machine should be performed on a firm level site, the procedure for detachment is as follows:

- Place the machine in its central position.
- Lower and secure stand legs.
- Lower the machine fully to the ground.
- Switch off the tractor and remove its starting key.
- Detach hydraulic hoses from the tractor service and stow them neatly on the machine.
- Remove the PTO driveshaft.
- 'Chock' the rear roller to prevent movement of the machine during the detachment procedure and whilst in storage.
- Remove the top link and both pins from the lower attachment points.
- Carefully and slowly drive the tractor clear of the machine.
- Clean and lubricate the machine in preparation for next use.

Storage

For extended periods of storage it is advisable that the machine be kept in a clean dry environment protected from the elements to avoid risk of corrosion. The machine should be thoroughly cleaned and lubricated prior to storage. At this point it is good practice to check the machine for worn or damaged components - any parts that require replacing should be ordered and fitted at the earliest opportunity so the machine is fully prepared for the next seasons work.

DRIVE BELTS

Power from the tractor via the machines gearbox is transferred to the rotor through sets of belts – 160 models employ a 3 belt system and 190/225 models employ a 4 belt system. It is important for both optimal machine performance and long lasting belt life that belts are correctly tensioned at all times. Tension is correct when a force of 10 kg exerted on the belts at their mid-point between the upper and lower pulleys deviates the belts by 15mm. If the belts require tensioning follow the procedure stated below.

NOTE:

After an initial first 2 hours of work check belt tension and taper locks (*indicated 1 & 2 in the photos below right*) – tighten if required. The torque setting for Taper Lock bolts is 45Nm.

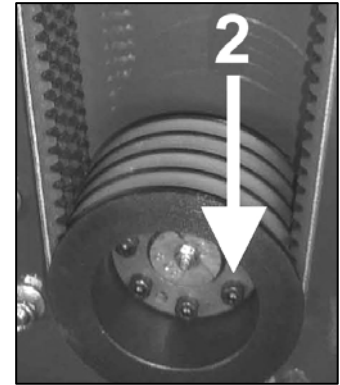
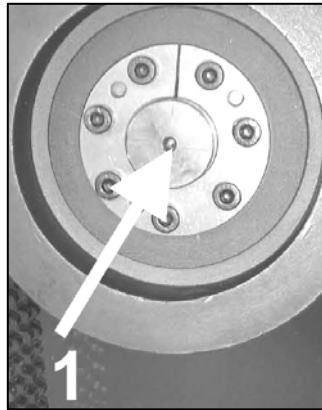
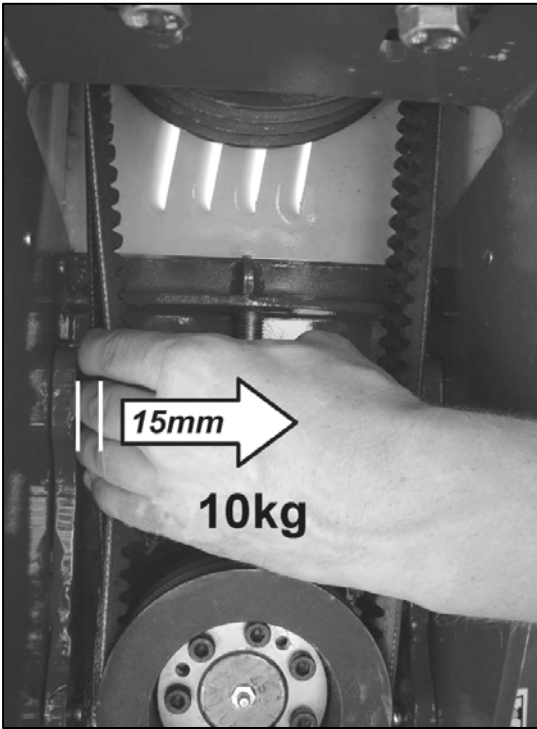

▲ Taper Locks

Check tightness on new machine after an initial 2 hours of work and at regular intervals thereafter.

Tighten taper locks using a circular sequence repeating at least 4 times until fully tightened.

◀ Belt Tension – 15mm deviation under 10kg pressure at mid-point of belt run

Belt Tension Adjustment

To adjust belt tension, remove the upper belt shield 'A' and release the four gearbox support bolts 'B' and adjuster lock nut 'C' (*indicated below and opposite*), adjuster bolt 'D' can then be turned to increase or decrease belt tension until belt deviation matches the required measurement (*refer above*).

Belt tensioning should be performed when the belts are cold.

Re-tighten lock nut 'C' and bolts 'B' when the correct tension is achieved. Replace belt shield before attempting to start the machine.

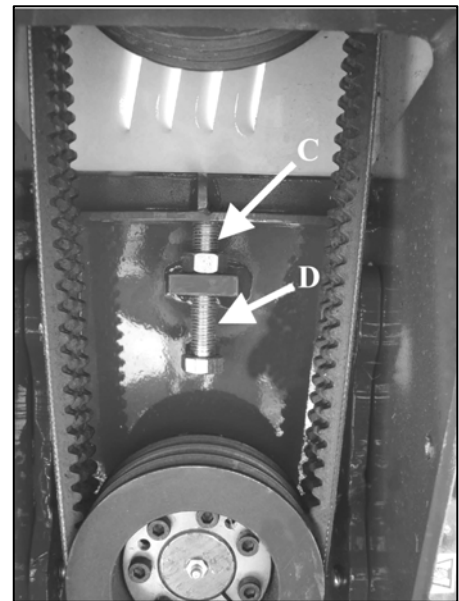
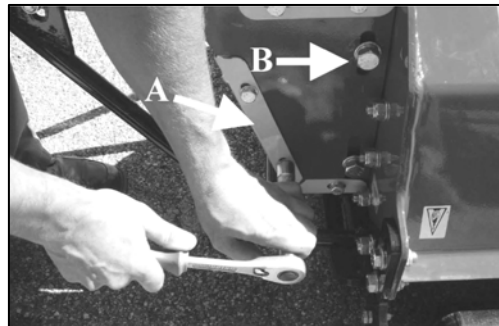

WARNING: Checking of belts and drive components should only be carried out with tractors engine switched off, starting key removed and the PTO shaft disconnected. Never attempt to run the machine with the belt guard removed.

FLAILS

As standard the machine is equipped with hammer type flails or Y-blades as an option. Hammer flails are best suited for work with harder types of materials up to 50mm diameter whereas the Y-blades are more suited to lighter duty work with materials up to 30mm. As the rotor spins the tools cut and lift the material into the frame of the machine, as the materials fall they are 'chopped' several times by the rotating blades before finally exiting the rear of the mower.

Two types of flails are available for use with these machines, these are shown below;

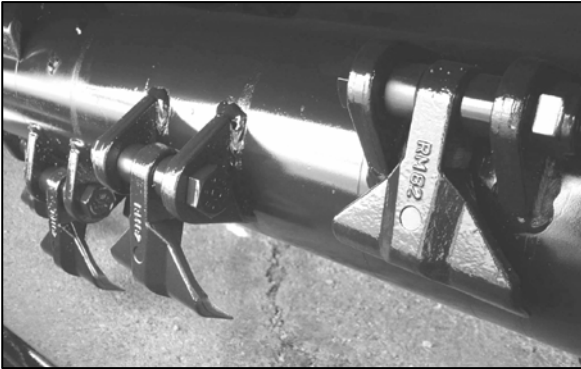

Hammer Flails

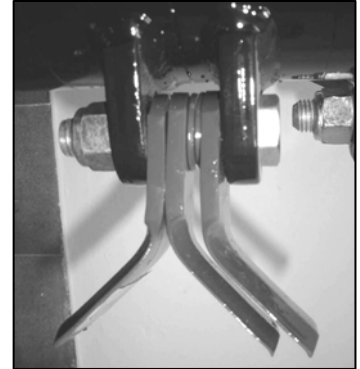

Y-blade Flails

Head Connection Bolts

All nuts and bolts on the machine should be regularly checked for tightness especially those connecting the head to the arm of the machine – *indicated opposite* ►

Always check these prior to starting and at regular intervals during work.

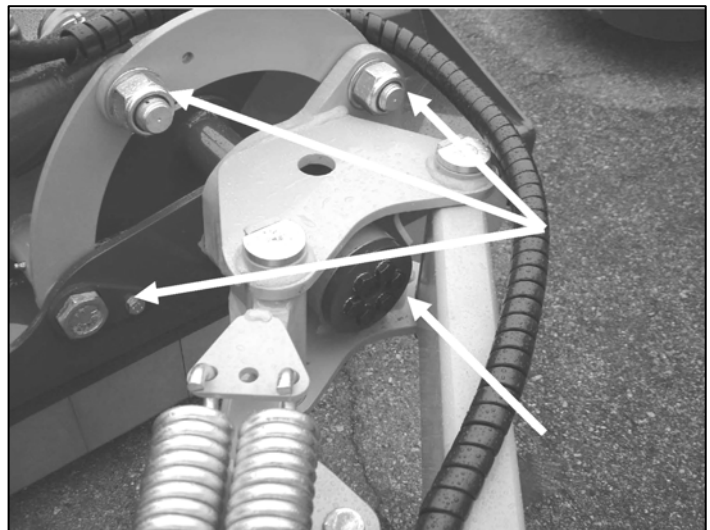

MAINTENANCE

All maintenance, cleaning and repair operations must be performed with the machine firmly lowered to the ground and detached from the tractor or with the PTO disconnected, engine switched off and starting key removed. For any repairs or maintenance that requires access from underneath, the machine should be firmly and safely raised and propped using suitable purpose designed supports capable of bearing the machines full weight. Care should be adopted at all times when working with or under a raised machine.

Maintenance Tasks

The following preventative maintenance tasks should be performed at the timescales stated to both maximise efficiency and prolong the working life of the machine.

After first 2 hours of work - new machine or machine fitted with new belts.

- ✓ Check all nuts and bolt for tightness – *retighten if required.*
- ✓ Check belt tension and adjust if required – *refer to belt section for details of adjustment.*

After every 8 hours of work

- ✓ Check all nuts and bolt for tightness – *retighten if required.*
- ✓ Check belt tension and adjust if required – *refer to belt section for details of adjustment.*
- ✓ Check wear and condition of flails – *replacing missing, or damaged flails immediately.*
- ✓ Check condition of safety guards – *repair or replace if not performing their function.*
- ✓ Lubricate grease points – *see below for locations of the machines grease points.*
- ✓ Check gearbox oil level – *top up if required.*
- ✓ Check rotor – *remove foreign objects that may be fouling or lodged in the rotor.*
- ✓ Check frame and 3-point hitch – *ensure all components are in a safe working condition.*

After every 100 hours

- ✓ Grease PTO driveshaft – *separate telescopic drive and apply grease to internal shaft.*

Every 12 months

- ✓ Change gearbox oil.

Gearbox Lubrication

Access to the gearbox for filling or 'topping up' with oil is via upper plug (1) indicated in the photo opposite. Remove level plug (2) and fill via the upper plug to a point where the oil starts to 'dribble' from the level plug, replace and tighten both plugs. For oil changes a drain plug is located under the fixing plate (3), removal of the plate will allow access to the plug.

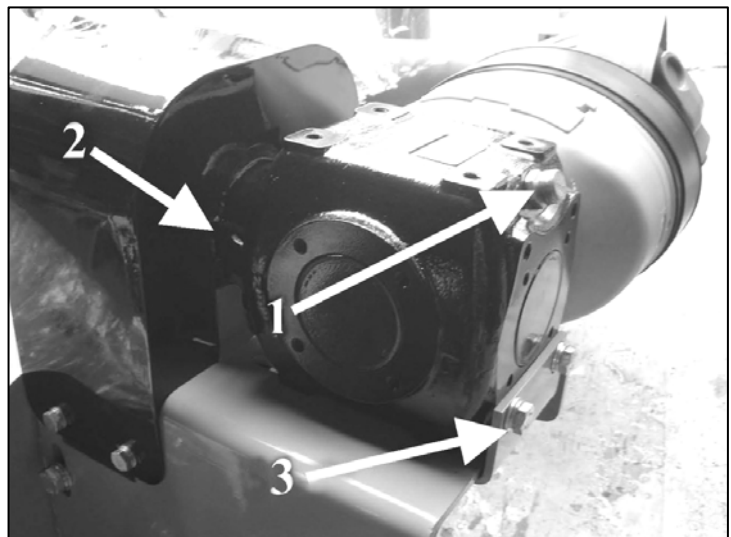

Oil Capacity and Type

1.2 Litres approx.
SAE 90 Lubricant

Grease Points - Lubricate the points indicated below using type LIS 3 grease.

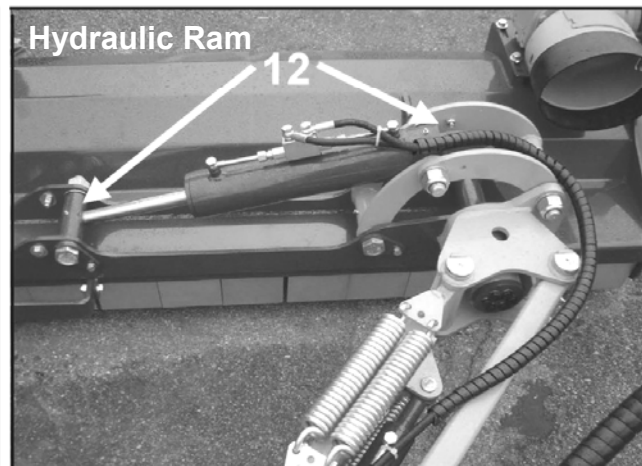
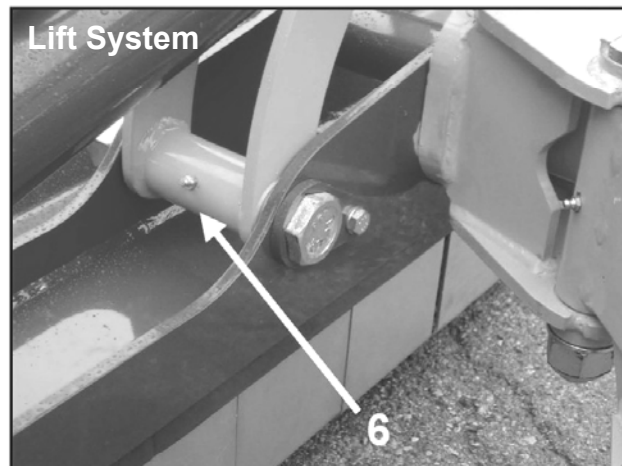
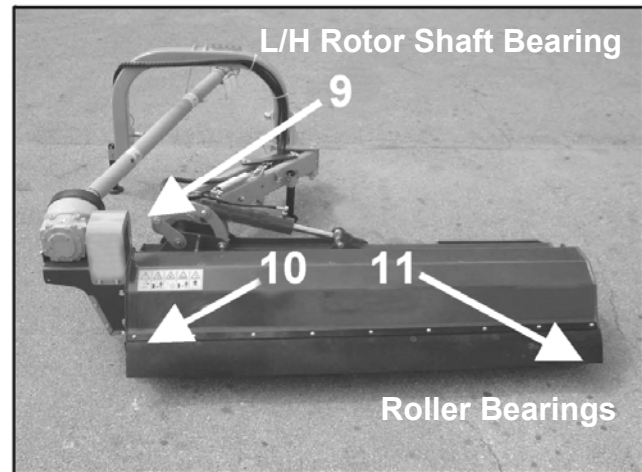
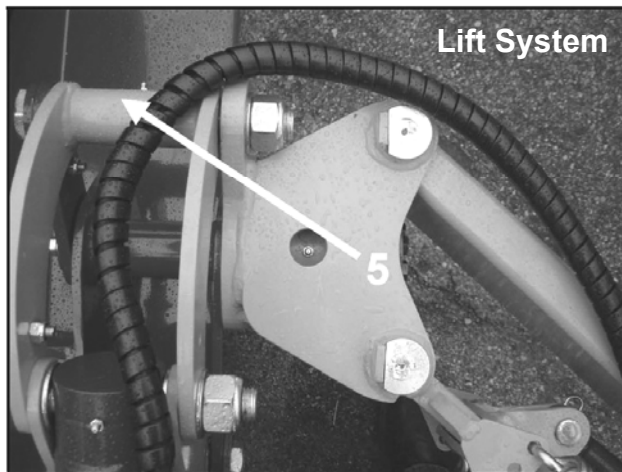
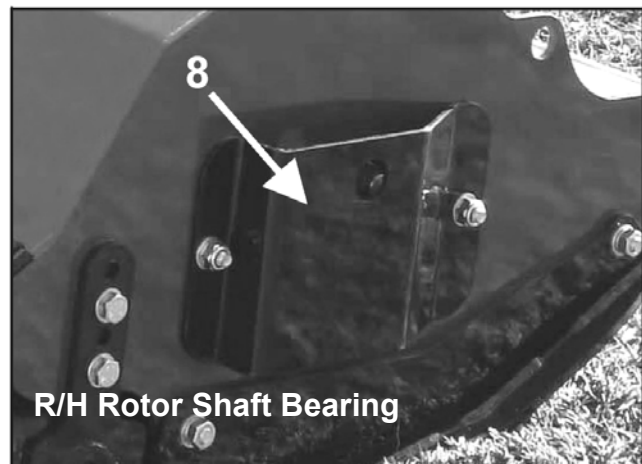
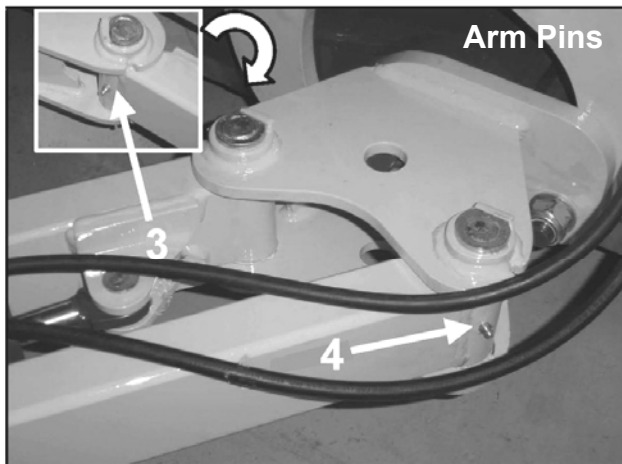
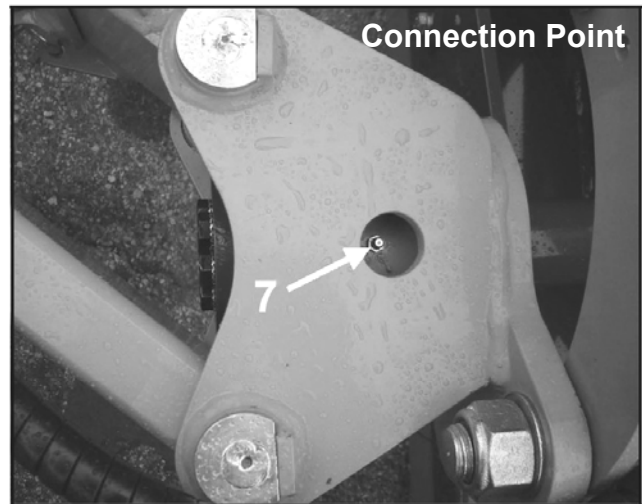
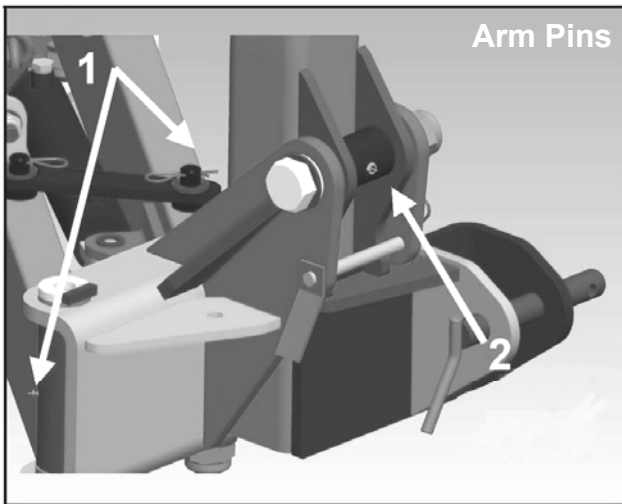

Flail replacement

The rotor and flails should be inspected for wear or damage on a regular basis – missing, damaged or worn flails should be replaced immediately. When replacing a flail the diametrically opposite flail should also be replaced at the same time in order to maintain rotor balance.

DANGER: Machine and tractor should be switched off and the starting key removed at all times when inspecting or maintaining the machine – Never work on a machine that is switch on and running.

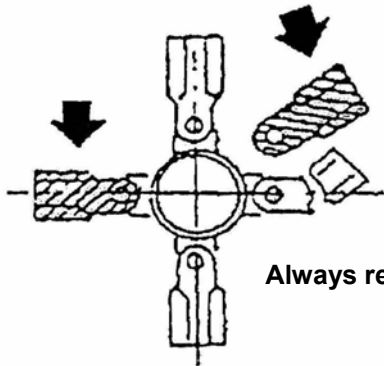

Always replace flails in opposing pairs

Rotor Vibration

If vibration of the rotor is experienced the machine should be stopped immediately – this is often a sign that a flail is either missing or severely damaged, if this is the case do not use the machine until the problem has been rectified. If vibration continues, or occurs for no apparent reason, the rotor must be checked and, if necessary, rebalanced before using the machine again. Contact your local dealer for further advice or assistance on this subject.

TROUBLESHOOTING

Problem	Possible Causes	Remedies
Irregular Cut	Worn, bent or broken flails	<i>Replace flails</i>
	RPM too low	<i>Increase RPM</i>
	Machine not level to the ground	<i>Correct mounting on tractor</i>
	Clogged material caused by excessive forward speed	<i>Reduce forward speed</i>
Noise	Loose bolts	<i>Check and tighten bolts</i>
	Damaged components	<i>Repair or replace</i>
Noisy gearbox	Lack of lubrication	<i>Top up oil to correct level</i>
	Worn gears	<i>Replace worn components</i>
	Worn bearings	<i>Replace worn components</i>
Vibration	Broken, worn or missing flails	<i>Replace flails</i>
	Rotor out of balance	<i>Balance or replace rotor</i>
	Worn rotor bearings	<i>Replace rotor bearings</i>
Excessive backlash in joints	Worn pins	<i>Replace pins</i>
Tight bearings	Bearings dirty or ungreased	<i>Clean and grease</i>
	Violent lowering down of machine	<i>Lower machine gently</i>
Belts overheating	Belts slipping on pulleys	<i>Tension belts</i>
	Flails contacting the ground	<i>Raise cutting height</i>
	Working speed too high	<i>Reduce working speed</i>

Machine Disposal

Disposal of this machine and any of its component parts must be performed in a responsible and inoffensive manner respecting all current laws relating to this subject. Materials forming this machine that must undergo differentiated division and disposal are:

- Steel
- Mineral Oil
- Rubber
- Plastic

MAGNUM Elite Offset
Models 160 / 190 / 225

Parts Manual
(Rev. 28.08.14)

For machines prior to S/N: M1538189

MOWER ASSEMBLY



MAGNUM Elite Offset 160 / 190 / 225

REF	DESCRIPTION	PART No.	QUANTITY		
			160	190	225
1	PIN	1061532	2	2	2
2	NUT	1061121	4	4	4
3	NUT	9113007	1	1	1
4	NUT	9163004	8	9	10
5	NUT	9163005	23	24	26
6	NUT	9163006	4	4	4
7	NUT	1061042	38	42	46
8	NUT	9163007	2	2	2
9	NUT	1061343	1	1	1
10	WASHER	9100104	10	11	12
11	WASHER	9100105	31	32	34
12	WASHER	9100106	2	2	2
13	WASHER	05.281.14	23	23	23
14	WASHER	1000106	8	8	8
15	WASHER	9100108	2	2	2
16	WASHER	1062006	17	17	17
17	SPRING WASHER	9100205	11	11	11
18	SPRING WASHER	9100206	3	3	3
19	SPRING WASHER	05.282.08	4	4	4
20	SPRING WASHER	9100207	10	10	10
21	BOLT	9313064	6	7	8
22	BOLT	9313075	3	3	3
23	BOLT	9313025	1	1	1
24	BOLT	9313076	5	5	5
25	BOLT	9313067	10	10	10
26	BOLT	9313148	16	16	16
27	SAFETY PIN	1061076	6	6	6
28	PIN	1061097	1	1	1
29	GREASE NIPPLE	1061554	2	2	2
30	GREASE NIPPLE	1061079	2	2	2
31	CIRCLIP	1061174	2	2	2
32	CIRCLIP	1061175	1	1	1
33	BELT	21233.01	3	4	4
34	SPLIT PIN	1061077	1	1	1
35	BEARING CASING - L	1061160	1	1	1
36	BEARING CASING - R	1061161	1	1	1
37	PULLEY 180/80-4	1061114	-	1	1
	PULLEY 180/80-3	1061164	1	-	-
38	CLUTCH ELVE 45/80	1061163	2	2	2
39	FLAP 140	1061171	11	12	15
	FLAP 50	1061482	1	-	-
	FLAP 70	1061170	-	1	-
40	BEARING GUARD - L	1061176	1	1	1
41	BEARING GUARD - R	1061177	1	1	1
42	PIN	1061168	1	1	1

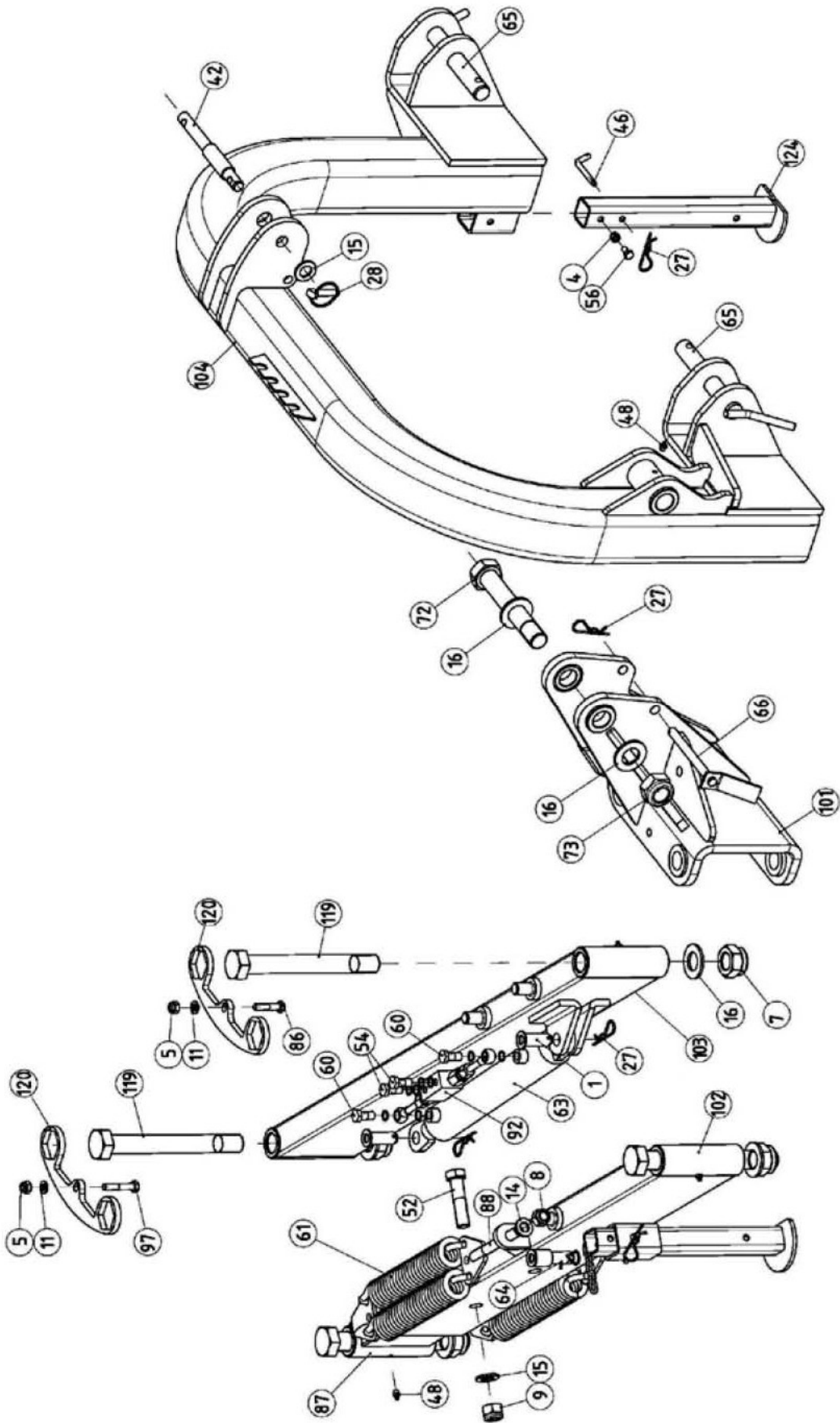

MOWER ASSEMBLY



MAGNUM Elite Offset 160 / 190 / 225

REF	DESCRIPTION	PART No.	QUANTITY		
			160	190	225
43	BOLT	9213066	2	2	2
44	FLAP BAR 160	1062009	1	-	-
	FLAP BAR 190	1061158	-	1	-
	FLAP BAR 225	1061109	-	-	1
45	BEARING	1061173	2	2	2
46	PIN	1061083	2	2	2
47	WASHER	1062010	4	4	4
48	GREASE NIPPLE	1061310	8	8	8
49	HAMMER	1061100	20	24	28
50	BOLT	1061687	6	6	6
51	PULLEY 130/80-3	1061162	1	-	-
	PULLEY 130/80-4	1061113	-	1	1
52	BOLT	1062068	1	1	1
53	PTO SHAFT SHIELD	1061046	1	1	1
54	BOLT	1062016	4	4	4
55	WASHER	1062069	16	16	16
56	BOLT	9313034	6	6	6
57	BOLT	1062017	10	10	10
58	BOLT	9313105	4	4	4
59	WASHER	1061120	1	1	1
60	BOLT	1062019	4	4	4
61	SPRING	1062020	2	4	4
62	FRAME GUARD	1062022	1	1	1
63	HYDRAULIC RAM	1062023	1	-	-
	HYDRAULIC RAM	1062024	-	1	1
64	PIN	1062025	1	1	1
65	PIN	1062026	2	2	2
66	PIN	1062027	1	1	1
67	SCRAPER 160	1062029	1	-	-
	SCRAPER 190	1061452	-	1	-
	SCRAPER 225	1061453	-	-	1
68	GREASE NIPPLE	1061674	2	2	2
69	BOLT	1061542	20	24	28
70	ROTOR 160 c/w BEARINGS	1062031	1	-	-
	ROTOR 190 c/w BEARINGS	1061543	-	1	-
	ROTOR 225 c/w BEARINGS	1061545	-	-	1
71	BUSHING	1062033	2	2	2
72	BOLT	1062035	2	3	3
	BOLT	1062071	1	-	-
73	NUT	1062036	9	9	9
74	BOLT	9213127	1	1	1
75	BUSHING	1062072	1	1	1
76	WASHER	1062037	6	6	6
77	LEVER (RIGHT)	1062039	1	1	1
78	LEVER (LEFT)	1062040	1	1	1

MOWER ASSEMBLY

MAGNUM Elite Offset 160 / 190 / 225

McCONEL

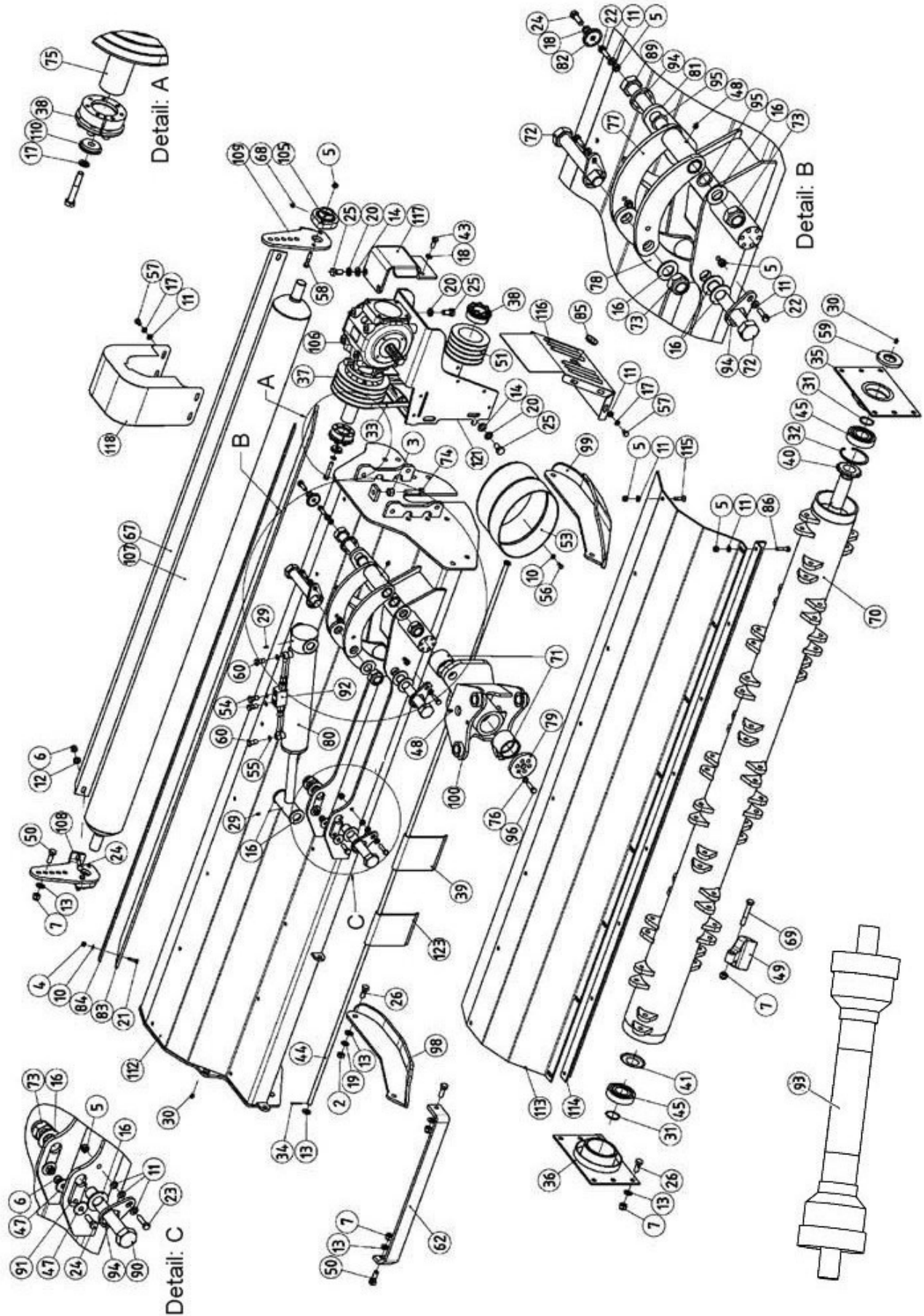

Taper Lock torque setting = 45Nm

MOWER ASSEMBLY



MAGNUM Elite Offset 160 / 190 / 225

REF	DESCRIPTION	PART No.	QUANTITY		
			160	190	225
79	WASHER	1062041	1	1	1
80	HYDRAULIC RAM	1062042	1	-	-
	HYDRAULIC RAM	1062043	-	1	1
81	LEVER	1062044	1	1	1
82	WASHER	1062045	1	1	1
83	RUBBER GUARD 160	1062100	1	-	-
	RUBBER GUARD 190	1062099	-	1	-
	RUBBER GUARD 225	1062098	-	-	1
84	BAR 160	1062103	1	-	-
	BAR 190	1062102	-	1	-
	BAR 225	1062101	-	-	1
85	CAP	1062046	1	1	1
86	BOLT	9213095	1	1	1
87	INSERT	1062051	1	1	1
88	SPRING TENSIONER	1062052	2	2	2
89	BOLT	1062053	1	1	1
90	BOLT	1062054	1	1	1
91	FLOAT LOCK	1062055	1	1	1
92	VALVE (COMPLETE)	1062056	2	2	2
93	PTO SHAFT	1062154	1	1	1
94	PIN LOCK	1062059	4	4	4
95	WASHER	1062155	2	2	2
96	BOLT	9313086	6	6	6
97	BOLT	1062129	1	1	1
98	SKID (LEFT)	1062086	1	1	1
99	SKID (RIGHT)	1062087	1	1	1
100	CONNECTION	1062038	1	1	1
101	CONNECTION 160	1062057	1	-	-
	CONNECTION 190/225	1062058	-	1	1
102	ARM - R	1062050	1	1	1
103	ARM - L	1062021	1	1	1
104	LINKAGE 160	1062047	1	-	-
	LINKAGE 190/225	1062048	-	1	1
105	BEARING c/w CASING	1061415	2	2	2
106	GEARBOX	1062156	1	1	1
107	REAR ROLLER 160	1062012	1	1	1
	REAR ROLLER 190	1061153	1	1	1
	REAR ROLLER 225	1061107	1	1	1
108	ROLLER BRACKET - R	1062157	1	1	1
109	ROLLER BRACKET - L	1062158	1	1	1
110	WASHER	1062159	1	1	1
111	BOLT	9213125	1	1	1
112	FRAME 160	1062170	1	-	-
	FRAME 190	1062169	-	1	-
	FRAME 225	1062168	-	-	1

MOWER ASSEMBLY**McCONNEL**

MAGNUM Elite Offset 160 / 190 / 225

REF	DESCRIPTION	PART No.	QUANTITY		
			160	190	225
113	INNER SKIN - 160	1062162	1	-	-
	INNER SKIN - 190	1062161	-	1	-
	INNER SKIN - 225	1062160	-	-	1
114	BAR 160	1062165	1	-	-
	BAR 190	1062164	-	1	-
	BAR 225	1062163	-	-	1
115	BOLT	9213085	5	6	8
116	BELT SHIELD	1062166	1	1	1
117	GUARD	1062167	1	1	1
118	BELT SHIELD UPPER	1062233	1	1	1
119	BOLT	1062231	4	4	4
120	LOCK BAR	1062232	2	2	2
121	GEARBOX SUPPORT	1062195	1	1	1
122	N/A	-	-	-	-
123	FLAP	1061098	-	1	2
124	SUPPORT LEG	1061632	2	2	2



McConnel Limited, Temeside Works, Ludlow, Shropshire SY8 1JL. England.
Telephone: 01584 873131. Facsimile: 01584 876463. www.mcconnel.com