

Publication 590
April 2009
Part No. 41571.90
Revision: 27.01.15



McCONEL

MERLIN *Xtreme*

2000 / 2500 / 2800

Flail Mowers

Operator & Parts Manual



IMPORTANT

VERIFICATION OF WARRANTY REGISTRATION

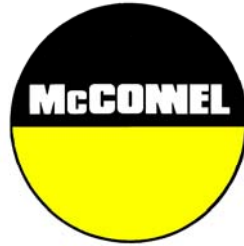

DEALER WARRANTY INFORMATION & REGISTRATION VERIFICATION

It is imperative that the selling dealer registers this machine with McConnel Limited before delivery to the end user – failure to do so may affect the validity of the machine warranty.

To register machines go to the McConnel Limited web site at www.mcconnel.com, log onto 'Dealer Inside' and select the 'Machine Registration button' which can be found in the Service Section of the site. Confirm to the customer that the machine has been registered in the section below.

Should you experience any problems registering a machine in this manner please contact the McConnel Service Department on 01584 875848.

Registration Verification

Dealer Name:
Dealer Address:
Customer Name:
Date of Warranty Registration:/...../..... Dealer Signature:

NOTE TO CUSTOMER / OWNER

Please ensure that the above section above has been completed and signed by the selling dealer to verify that your machine has been registered with McConnel Limited.

IMPORTANT: During the initial 'bedding in' period of a new machine it is the customer's responsibility to regularly inspect all nuts, bolts and hose connections for tightness and re-tighten if required. New hydraulic connections occasionally weep small amounts of oil as the seals and joints settle in – where this occurs it can be cured by re-tightening the connection – *refer to torque settings chart below*. The tasks stated above should be performed on an hourly basis during the first day of work and at least daily thereafter as part of the machines general maintenance procedure.

TORQUE SETTINGS FOR HYDRAULIC FITTINGS

HYDRAULIC HOSE ENDS		
BSP Setting		Metric
1/4"	18 Nm	19 mm
3/8"	31 Nm	22 mm
1/2"	49 Nm	27 mm
5/8"	60 Nm	30 mm
3/4"	80 Nm	32 mm
1"	125 Nm	41 mm
1.1/4"	190 Nm	50 mm
1.1/2"	250 Nm	55 mm
2"	420 Nm	70 mm

PORT ADAPTORS WITH BONDED SEALS		
BSP Setting		Metric
1/4"	34 Nm	19 mm
3/8"	47 Nm	22 mm
1/2"	102 Nm	27 mm
5/8"	122 Nm	30 mm
3/4"	149 Nm	32 mm
1"	203 Nm	41 mm
1.1/4"	305 Nm	50 mm
1.1/2"	305 Nm	55 mm
2"	400 Nm	70 mm

WARRANTY POLICY

WARRANTY REGISTRATION

All machines must be registered, by the selling dealer with McConnel Ltd, before delivery to the end user. On receipt of the goods it is the buyer's responsibility to check that the Verification of Warranty Registration in the Operator's Manual has been completed by the selling dealer.

1. LIMITED WARRANTIES

- 1.01. *All mounted machines supplied by McConnel Ltd are warranted to be free from defects in material and workmanship from the date of sale to the original purchaser for a period of 12 months, unless a different period is specified.*
All Self Propelled Machines supplied by McConnel Ltd are warranted to be free from defects in material and workmanship from the date of sale to the original purchaser for a period of 12 months or 1500 hours. Engine warranty will be specific to the Manufacturer of that unit.
- 1.02. *All spare parts supplied by McConnel Ltd and purchased by the end user are warranted to be free from defects in material and workmanship from the date of sale to the original purchaser for a period of 6 months. All parts warranty claims must be supported by a copy of the failed part invoice to the end user. We cannot consider claims for which sales invoices are not available.*
- 1.03. *The warranty offered by McConnel Ltd is limited to the making good by repair or replacement for the purchaser any part or parts found, upon examination at its factory, to be defective under normal use and service due to defects in material or workmanship. Returned parts must be complete and unexamined. Pack the component(s) carefully so that any transit damage is avoided. All ports on hydraulic items should be drained of oil and securely plugged to prevent seepage and foreign body ingress. Certain other components, electrical items for example, may require particular care when packing to avoid damage in transit.*
- 1.04. *This warranty does not extend to any product from which McConnel Ltd's serial number plate has been removed or altered.*
- 1.05. *The warranty policy is valid for machines registered in line with the terms and conditions detailed and on the basis that the machines do not extend a period of 24 months or greater since their original purchase date, that is the original invoice date from McConnel Limited.*
Machines that are held in stock for more than 24 months cannot be registered for warranty.
- 1.06. *This warranty does not apply to any part of the goods, which has been subjected to improper or abnormal use, negligence, alteration, modification, fitment of non-genuine parts, accident damage, or damage resulting from contact with overhead power lines, damage caused by foreign objects (e.g. stones, iron, material other than vegetation), failure due to lack of maintenance, use of incorrect oil or lubricants, contamination of the oil, or which has served its normal life. This warranty does not apply to any expendable items such as blades, belts, clutch linings, filter elements, flails, flap kits, skids, soil engaging parts, shields, guards, wear pads, pneumatic tyres or tracks.*
- 1.07. *Temporary repairs and consequential loss - i.e. oil, downtime and associated parts are specifically excluded from the warranty.*
- 1.08. *Warranty on hoses is limited to 12 months and does not include hoses which have suffered external damage. Only complete hoses may be returned under warranty, any which have been cut or repaired will be rejected.*
- 1.09. *Machines must be repaired immediately a problem arises. Continued use of the machine after a problem has occurred can result in further component failures, for which McConnel Ltd cannot be held liable, and may have safety implications.*
- 1.10. *If in exceptional circumstances a non McConnel Ltd part is used to effect a repair, warranty reimbursement will be at no more than McConnel Ltd's standard dealer cost for the genuine part.*

- 1.11. *Except as provided herein, no employee, agent, dealer or other person is authorised to give any warranties of any nature on behalf of McConnell Ltd.*
- 1.12. *For machine warranty periods in excess of 12 months the following additional exclusions shall apply:*
 - 1.12.1. *Hoses, exposed pipes and hydraulic tank breathers.*
 - 1.12.2. *Filters.*
 - 1.12.3. *Rubber mountings.*
 - 1.12.4. *External electric wiring.*
 - 1.12.5. *Bearings and seals*
 - 1.12.6. *External Cables, Linkages*
 - 1.12.7. *Loose/Corroded Connections, Light Units, LED's*
 - 1.12.8. *Comfort items such as Operator Seat, Ventilation, Audio Equipment*
- 1.13. *All service work, particularly filter changes, must be carried out in accordance with the manufacturer's service schedule. Failure to comply will invalidate the warranty. In the event of a claim, proof of the service work being carried out may be required.*
- 1.14. *Repeat or additional repairs resulting from incorrect diagnosis or poor quality previous repair work are excluded from warranty.*

NB Warranty cover will be invalid if any non-genuine parts have been fitted or used. Use of non-genuine parts may seriously affect the machine's performance and safety. McConnell Ltd cannot be held responsible for any failures or safety implications that arise due to the use of non-genuine parts.

2. REMEDIES AND PROCEDURES

- 2.01. *The warranty is not effective unless the Selling Dealer registers the machine, via the McConnell web site and confirms the registration to the purchaser by completing the confirmation form in the operator's manual.*
- 2.02. *Any fault must be reported to an authorised McConnell Ltd dealer as soon as it occurs. Continued use of a machine, after a fault has occurred, can result in further component failure for which McConnell Ltd cannot be held liable.*
- 2.03. *Repairs should be undertaken within two days of the failure. Claims submitted for repairs undertaken more than 2 weeks after a failure has occurred, or 2 days after the parts were supplied will be rejected, unless the delay has been authorised by McConnell Ltd. Please note that failure by the customer to release the machine for repair will not be accepted as a reason for delay in repair or submitting warranty claims.*
- 2.04. *All claims must be submitted, by an authorised McConnell Ltd Service Dealer, within 30 days of the date of repair.*
- 2.05. *Following examination of the claim and parts, McConnell Ltd will pay, at their discretion, for any valid claim the invoiced cost of any parts supplied by McConnell Ltd and appropriate labour and mileage allowances if applicable.*
- 2.06. *The submission of a claim is not a guarantee of payment.*
- 2.07. *Any decision reached by McConnell Ltd. is final.*

3. LIMITATION OF LIABILITY

- 3.01. *McConnell Ltd disclaims any express (except as set forth herein) and implied warranties with respect to the goods including, but not limited to, merchantability and fitness for a particular purpose.*
- 3.02. *McConnell Ltd makes no warranty as to the design, capability, capacity or suitability for use of the goods.*
- 3.03. *Except as provided herein, McConnell Ltd shall have no liability or responsibility to the purchaser or any other person or entity with respect to any liability, loss, or damage caused or alleged to be caused directly or indirectly by the goods including, but not limited to, any indirect, special, consequential, or incidental damages resulting from the use or operation of the goods or any breach of this warranty. Notwithstanding the above limitations and warranties, the manufacturer's liability hereunder for damages incurred by the purchaser or others shall not exceed the price of the goods.*
- 3.04. *No action arising out of any claimed breach of this warranty or transactions under this warranty may be brought more than one (1) year after the cause of the action has occurred.*

4. MISCELLANEOUS

- 4.01. McConnel Ltd may waive compliance with any of the terms of this limited warranty, but no waiver of any terms shall be deemed to be a waiver of any other term.*
- 4.02. If any provision of this limited warranty shall violate any applicable law and is held to be unenforceable, then the invalidity of such provision shall not invalidate any other provisions herein.*
- 4.03. Applicable law may provide rights and benefits to the purchaser in addition to those provided herein.*

McConnel Limited



DECLARATION OF CONFORMITY

Conforming to EU Machinery Directive 2006/42/EC

We,

McCONNEL LIMITED, Temeside Works, Ludlow, Shropshire SY8 1JL, UK

Hereby declare that:

The Product; *Tractor Mounted Flail Mower / Shredder*

Product Code; *MEOS, MQ25, MQ28*

Serial No. & Date Type

Manufactured in; *United Kingdom*

Complies with the required provisions of the Machinery Directive 2006/42/EC
The machinery directive is supported by the following harmonized standards;

- BS EN ISO 12100 (2010) Safety of machinery – General principles for design – Risk assessment and risk reduction.
- BS EN 349 (1993) + A1 (2008) Safety of machinery - Minimum distances to avoid the entrapment with human body parts.
- BS EN ISO 14120 (2015) Safety of machinery - Guards general requirements for the design and construction of fixed and movable guards.
- BS EN 4413 (2010) Hydraulic fluid power. Safety requirements for systems and their components.

McCONNEL LIMITED operates an ISO 9001:2008 quality management system, certificate number: FM25970.

This system is continually assessed by the;

British Standards Institution (BSI), Beech House, Milton Keynes, MK14 6ES, UK

BSI is accredited by UK Accreditation Service, accreditation number: UKAS 003.

The EC declaration only applies if the machine stated above is used in accordance with the operating instructions.

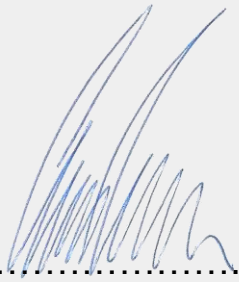
Signed  *Responsible Person*
CHRISTIAN DAVIES on behalf of McCONNEL LIMITED

Status: *General Manager*

Date: *January 2018*

FLAIL MOWER INSPECTION AND MAINTENANCE

A daily equipment inspection of the tractor and mower should be conducted before the equipment is used. You may use the inspection sheets to assist with these daily inspections. Any damaged or missing guards should be repaired or replaced before operating the mower. Failure to repair the damaged shield can result in objects being thrown from the mower and possibly hitting the operator or bystander.

Inspect the Mower for Safe Operating Condition

- Make sure the driveline guards and shielding are in place and in good repair.
- Inspect the chain guards, flexible and/or solid deflector thrown object shielding to assure that they are in place on the front and rear of the mower deck and in good repair. Repair or replace any damaged or missing thrown object shields.
- Ensure the mower cutting height is set high enough to reduce the possibility of the mower blades contacting the ground. Actual height will be dependent on the ground conditions. Increase the height when working in rough or undulating conditions.
- Inspect for broken, chipped, bent, missing, or severely worn blades. Replace damaged blades before operating the mower. Ensure the blade retaining bolts and fasteners are secure and tight.
- Lubricate the driveline universal joints and telescoping members daily.
- Inspect the wheel lug bolt/nuts to assure that they are tight.
- If mower is equipped with pneumatic tires, make sure they have the required air pressure.
- Inspect for worn or damaged decals and safety instructions. Replace unreadable, damaged or missing safety decals.
- Follow the operator's manual(s) inspection and maintenance instructions for lubricating parts, and keeping thrown object shielding, driveline guards, rotating parts shields, mower blades and decals in good repair.

Inspect the Tractor for Safe Operating Condition:

- Inspect the controls, lights, SMVs (Slow Moving Vehicle sign), seat belts, and ROPS to assure that they are in place and in good working order.
- Be sure the tires, wheels, lug bolts/nuts are in good condition.
- Make sure the tractor brakes and steering are in proper operating condition.
- Follow the operator's manual(s) inspection and maintenance procedures for keeping the tractor in good and safe condition before operating.

The inspection sheet on the following page should be kept in this book as a record. A second sheet is included for you to cut out and photocopy or the inspection sheets can be downloaded from our website at;

<http://www.mcconnel.com/support/aftersales/default.aspx?nav=After Sales>



FLAIL MOWERS PRE-OPERATION Inspection

Mower ID _____ Date: _____ Shift: _____

WARNING



Before conducting the inspection, make sure the tractor engine is off, with the key removed, all rotation has stopped and the tractor is in park with the parking brake engaged. Make sure the mower is resting on the ground or is securely blocked up and supported and all hydraulic pressure has been relieved.

Item	Condition at start of shift	Specific Comments if not O.K.
The Operator's Manual is in the Canister on the mower		
All Warning Decals are in place, clean and legible		
The Hyd. Cylinder pins are tight and correctly secured		
The Hyd Cylinder hose connections are tight		
There are no oil leaks		
There are no damaged hoses		
Flails are not missing chipped, broken or excessively worn		
The Flail bolts are tight		
The Front & Rear Flaps are fitted and in good condition		
The Skid shoes are in good condition & tight		
The Rotor Bearings are in good condition and greased		
The Roller bearings are in good condition and greased		
There are no cracks or holes in flail casing		
The drive line/gearbox shaft guard is in good condition		
The drive line/gearbox shaft guard is correctly secured		
Driveline telescoping members & u-joints are lubricated		
Driveline yokes are securely attached to tractor & mower		
All linkage mounting pins are securely fastened		

Operators Signature: _____

DO NOT OPERATE an UNSAFE TRACTOR or MOWER



TRACTOR PRE-OPERATION Inspection

Power Arm ID _____ Date: _____ Shift: _____

WARNING



Before conducting the inspection, make sure the tractor engine is off, the key is removed all rotation has stopped and the tractor is in park with the parking brake engaged. Any implement attached to the tractor is firmly on the ground.

Item	Condition at start of shift	Specific Comments if not O.K.
The flashing lights function properly.		
All lights are clean and working correctly		
All cab windows are clean and wipers working correctly		
The SMV sign, where required, is clean and visible.		
The tyres are in good condition with correct pressure.		
The wheel nuts are tight.		
The tractor brakes are in good condition.		
The steering linkage is in good condition.		
There are no visible oil leaks.		
The hydraulic controls function properly.		
The ROPS or ROPS cab is in good condition.		
The seatbelt is in place and in good condition.		
The 3-point hitch is in good condition.		
The drawbar/pick up hook is secure & in good condition		
The PTO master shield is in place.		
The engine oil level is full.		
The brake fluid level is full.		
The power steering fluid level is full.		
The fuel level is adequate.		
The engine coolant fluid level is full.		
The radiator & oil cooler are free of debris.		
The air filter is in good condition		

Operators Signature: _____

DO NOT OPERATE an UNSAFE TRACTOR or MOWER



FLAIL MOWERS PRE-OPERATION Inspection

Mower ID _____ Date: _____ Shift: _____

WARNING



Before conducting the inspection, make sure the tractor engine is off, with the key removed, all rotation has stopped and the tractor is in park with the parking brake engaged. Make sure the mower is resting on the ground or is securely blocked up and supported and all hydraulic pressure has been relieved.

Item	Condition at start of shift	Specific Comments if not O.K.
The Operator's Manual is in the Canister on the mower		
All Warning Decals are in place, clean and legible		
The Hyd. Cylinder pins are tight and correctly secured		
The Hyd Cylinder hose connections are tight		
There are no oil leaks		
There are no damaged hoses		
Flails are not missing chipped, broken or excessively worn		
The Flail bolts are tight		
The Front & Rear Flaps are fitted and in good condition		
The Skid shoes are in good condition & tight		
The Rotor Bearings are in good condition and greased		
The Roller bearings are in good condition and greased		
There are no cracks or holes in flail casing		
The drive line/gearbox shaft guard is in good condition		
The drive line/gearbox shaft guard is correctly secured		
Driveline telescoping members & u-joints are lubricated		
Driveline yokes are securely attached to tractor & mower		
All linkage mounting pins are securely fastened		

Operators Signature: _____

DO NOT OPERATE an UNSAFE TRACTOR or MOWER



TRACTOR PRE-OPERATION Inspection

Power Arm ID _____ Date: _____ Shift: _____

WARNING



Before conducting the inspection, make sure the tractor engine is off, the key is removed all rotation has stopped and the tractor is in park with the parking brake engaged. Any implement attached to the tractor is firmly on the ground.

Item	Condition at start of shift	Specific Comments if not O.K.
The flashing lights function properly.		
All lights are clean and working correctly		
All cab windows are clean and wipers working correctly		
The SMV sign, where required, is clean and visible.		
The tyres are in good condition with correct pressure.		
The wheel nuts are tight.		
The tractor brakes are in good condition.		
The steering linkage is in good condition.		
There are no visible oil leaks.		
The hydraulic controls function properly.		
The ROPS or ROPS cab is in good condition.		
The seatbelt is in place and in good condition.		
The 3-point hitch is in good condition.		
The drawbar/pick up hook is secure & in good condition		
The PTO master shield is in place.		
The engine oil level is full.		
The brake fluid level is full.		
The power steering fluid level is full.		
The fuel level is adequate.		
The engine coolant fluid level is full.		
The radiator & oil cooler are free of debris.		
The air filter is in good condition		

Operators Signature: _____

DO NOT OPERATE an UNSAFE TRACTOR or MOWER

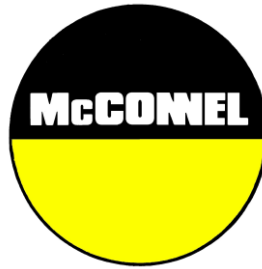

For Safety and Performance...

ALWAYS READ THE BOOK FIRST

McCONEL LIMITED

**Temeside Works
Ludlow
Shropshire
England**

**Telephone: +44 (0)1584 873131
www.mcconel.com**

- NOISE STATEMENT -

The equivalent daily personal noise exposure from this machine measured at the operators' ear is within the range 78 – 85 dB, these figures apply to a normal distribution of use where the noise fluctuates between zero and maximum. The figures assume that the machine is fitted to a tractor with a 'quiet' cab with the windows closed in a generally open environment. We recommend that the windows are kept closed. With the cab rear window open the equivalent daily personal noise exposure will increase to a figure within the range 82 – 88 dB. At an equivalent daily noise exposure level of 85 – 90 dB ear protection is recommended and must always be used if any window is left open.



Operating, servicing and maintaining this equipment can expose you to chemicals including gasoline, diesel fuel, lubricants, petroleum products, engine exhaust, carbon monoxide, and phthalates, which are known to the State of California to cause cancer and birth defects or other reproductive harm. To minimize exposure, avoid breathing exhaust, do not idle the engine except as necessary, service your vehicle in a well-ventilated area and wear gloves or wash your hands frequently when servicing your vehicle. Battery posts, terminals and related accessories contain lead and lead compounds, chemicals known to the state of California to cause cancer, birth defects or other reproductive harm. For more information go to www.P65Warnings.ca.gov. This website, operated by California's Office of Environmental Health Hazard Assessment, provides information about these chemicals and how individuals may be exposed to them.

CONTENTS

Operator Section

General Information	1
Introduction	2
Machine Identification	2
Tractor Requirements	2
Machine Specifications	3
Safety Information	4
Safety Decals	6
Vehicle/Tractor Preparation	7
Attaching to Tractor	8
PTO Driveshaft Installation	9
Setting Up & Adjustment	10
Operation	12
Rotor Care	12
Servicing & Maintenance	13
Troubleshooting	16

Parts Section

Main Assembly	19
Rotor & Roller Assembly	21
Headstock Assembly	23
Hydraulic Headstock Assembly	25
Wheel Kit Assembly (Hydraulic Headstock)	27
PTO Shaft Assembly	28
Cross Shaft Assembly	29
Gearbox Assembly	31
Safety & Information Decals	33
Identification Decals	34

GENERAL INFORMATION

Read this manual before fitting or operating the machine. Whenever any doubt exists contact your dealer or the McConnel Service Department for assistance.

Use only McConnel Genuine Parts on McConnel equipment and machines.

DEFINITIONS - The following definitions apply throughout this manual:

WARNING:

An operating procedure, technique etc., which can result in personal injury or loss of life if not observed carefully.

CAUTION:

An operating procedure, technique etc., which can result in the damage of either machine or equipment if not observed carefully.

NOTE:

An operating procedure, technique etc., which is considered essential to emphasise.

LEFT AND RIGHT HAND:

This term is applicable to the machine when fitted to the tractor and viewed from the rear. This also applies to tractor references.

Note: The illustrations in this manual are for instructional purposes only and may on occasion not show some components in their entirety. In some instances an illustration may appear slightly different to that of your particular model but the general procedure will be the same. E&OE.

MACHINE & DEALER INFORMATION

Record the Serial Number of your machine on this page and always quote this number when ordering parts. Whenever information concerning the machine is requested remember also to state the make and model of tractor to which the machine is fitted.

Machine Serial Number:	Installation Date:
Machine Model details:	
Dealer Name:	
Dealer Address:	
Dealer Telephone No:	
Dealer Email Address:	

INTRODUCTION

The McConnel Merlin Xtreme is a tractor mounted high capacity flail mower/shredder suitable for use on tractors of 50HP and above. Its robust construction along with ease of operation and maintenance makes it the ideal machine for farmers and contractors alike. In order to ensure trouble-free operation this manual should be carefully studied.

This machine should only be used to perform tasks for which it was designed – use of the machine for any other function may be both dangerous to persons and damaging to components and is therefore not advisable.

MACHINE IDENTIFICATION

Each machine is fitted with an identification plate with the following information:

1. Machine (Part Number)
2. Machine Serial No.
3. Machine Weight

When ordering spares or replacement parts from your local dealer it is important to quote both Part Number and Serial Number as stated on the identification plate so the machine and model can be quickly and correctly identified.



Machine Identification Plate

TRACTOR REQUIREMENTS

- Minimum 50 - 70HP tractor with category 2 linkage.
- Minimum tractor weight including ballast must be 2500kg.
- PTO must be independent live drive to enable continuous PTO drive even when tractor clutch is pressed down.
- Before hitching, ensure position control is selected. Do not attempt to hitch in draft control.
- Check chains and stabilizers must be in good working order to hold the machine firmly. Do not operate without checking that chains and stabilizers are tight.
- 'Turn buckle' type check chains are recommended.
- Set linkage lift rods to an equal length.
- Double acting spool for hydraulic offset models.
- Clockwise rotating tractor PTO as standard, anti-clockwise available as an option.

MACHINE SPECIFICATIONS

Specifications	2000 Model	2500 Model	2800 Model
Cutting Width	<i>2.0m (6' 7")</i>	<i>2.45m (8' 0")</i>	<i>2.65m (8' 8")</i>
HP Requirement	<i>50</i>	<i>60</i>	<i>70</i>
Weight	<i>730kg</i>	<i>814kg</i>	<i>860kg</i>
Attachment Type	<i>3-Point Linkage</i>	<i>3-Point Linkage</i>	<i>3-Point Linkage</i>
Cutting Height	<i>0 – 150mm</i>	<i>0 – 150mm</i>	<i>0 – 150mm</i>
Cutting Capacity	<i>50mm</i>	<i>50mm</i>	<i>50mm</i>
Overall Width	<i>2.3m</i>	<i>2.8m</i>	<i>3.0m</i>
PTO Speed	<i>1000rpm</i>	<i>1000rpm</i>	<i>1000rpm</i>
Machine Protection	<i>Slip Clutch</i>	<i>Slip Clutch</i>	<i>Slip Clutch</i>
Number of Flails	<i>48</i>	<i>60</i>	<i>66</i>
Offset	<i>Optional</i>	<i>Optional</i>	<i>Optional</i>
Roller Diameter	<i>168mm</i>	<i>168mm</i>	<i>168mm</i>
Skids	<i>2</i>	<i>2</i>	<i>2</i>

SAFETY INFORMATION

General safety rules:

- ▲ Always read and follow the instructions for the use and maintenance of the machine before carrying out any work operations or servicing tasks.
- ▲ Improper use of the machine is both highly dangerous to persons and damaging to the machine components – only use the machine for its designated task.
- ▲ Both operators and the maintenance fitters should be familiar with the machine and fully aware of dangers surrounding improper use or incorrect repairs.
- ▲ Before starting, checks to both tractor and machine must be carried out as regards: functionality, road safety, accident prevention rules.
- ▲ Even when using the machine correctly, stones or other objects may be thrown a long distance. Therefore nobody must stand within the danger area. Special attention must be paid when working near roads or buildings.
- ▲ Use tractor's fitted with safety cabs.
- ▲ The condition of flails and of machine guards must be checked before beginning the daily work - they must be replaced if damaged or missing before you use the machine.
- ▲ During checks or repairs, make sure nobody could start the machine by mistake.
- ▲ Never wear loose or fluttering clothes.
- ▲ Never carry passengers on the tractor.
- ▲ Never carry passengers on the machine.
- ▲ Never connect the power takeoff with the engine running.
- ▲ Never approach the machine until the rotor has completely stopped.
- ▲ Do not enter the working zone of the PTO shaft. It is dangerous to approach the rotating parts of a machine.
- ▲ Keep the PTO shaft guard in good condition.
- ▲ Before starting, check the surrounding area for the likely presence of children and/or animals.
- ▲ Do not stand near the machine when it is operating.
- ▲ The PTO shaft must be assembled and disassembled only with the engine stopped and the starting key removed.
- ▲ Before connecting the power takeoff, check that the speed and the rotational direction correspond to those of the machine.
- ▲ Immediately replace missing or damaged safety decals.
- ▲ Before leaving the tractor with the machine attached, proceed as follows:
 1. Disconnect the power takeoff,
 2. Put the machine steadily on the ground using the tractor's hydraulic lift.
 3. Apply the hand brake and, if the ground is steeply sloping, wedge the tractor.
 4. Remove the starting key.

Transportation Safety

- ▲ In transport, reduce speed, especially on bumpy roads, the weight of the machine may render driving difficult and damage the machine itself.
- ▲ Ensure the levers that operate the hydraulic lift are locked, to avoid the lowering of the machine during transport.
- ▲ When driving on public roads, respect all road rules in force.
- ▲ Never transport the machine with the rotor running, even for short distances.

Operating Safety

- ▲ Pay special attention when working with the machine not to touch fixed objects such as road drain, walls, shafts, kerbs, guard rails, tracks etc. This could cause the breakage of the flails, which would be thrown out of the machine at very high speed.
- ▲ If wires, ropes or chains should become entangled in the rotor stop immediately to prevent damage or dangerous situations; stop the rotor and the tractor, take out the starting key. Put working gloves on; clear the rotor with the aid of pliers or shears. Do not try to disentangle by inverting the rotational direction of the rotor.
- ▲ Do not use the machine when excessive vibration is experienced, as this may cause breakage and serious damage - find the cause of the vibration and eliminate it before using the machine again.

Although the information given here covers a wide range of safety subjects, it is impossible to predict every eventuality that can occur under differing circumstances whilst operating this machine. No advice given here can replace 'good common sense' and 'total awareness' at all times, but will go a long way towards the safe use of your McConnel machine.

SAFETY DECALS

In addition to company branding and model identification the following safety decals are displayed – familiarise yourself with, and heed the messages they state, they are there for your safety and guidance. If any of the safety decals go missing or become damaged beyond a readable state they should be replaced at the earliest possible opportunity.



WARNING!
Avoid fluid escaping under pressure. Consult technical manual for services procedures.



WARNING!
Shut off engine and remove key before performing maintenance or repair work.



WARNING!
Danger – flying objects keep safe distance from the machine as long as the engine is running.



WARNING!
Check all nuts are tight every 8 hours.



WARNING!
Stay clear of mower blade/flails as long as engine is running.



WARNING!
Carefully read operator's manual before handling this machine. Observe instructions and safety rules when operating.



WARNING!
Do not remove or open guard when machine is working.

VEHICLE / TRACTOR PREPARATION

We recommend vehicles are fitted with cabs using 'safety glass' windows and protective guarding when used with our machines.

Fit Operator Guard (*Part No. 7313324*) using the hooks provided. Shape the mesh to cover all vulnerable areas.

Remember the driver must be looking through mesh and/or polycarbonate

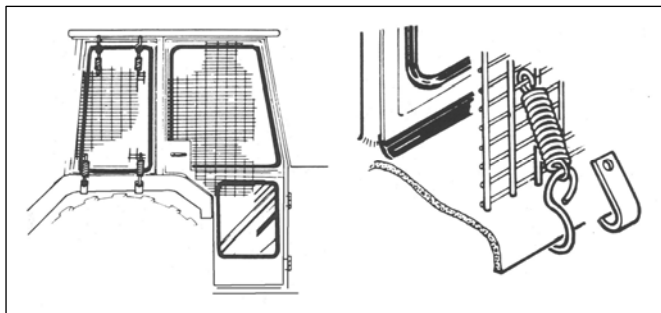

glazing when viewing the machine in all positions - unless the vehicle/ cab manufacturer can demonstrate that the penetration resistance is equivalent to, or higher than, that provided by mesh/polycarbonate glazing. If the tractor has a roll bar only, a frame must be made to carry both mesh and polycarbonate glazing. The operator should also use personal protective equipment to reduce the risk of serious injury such as; eye protection (mesh visor to EN1731 or safety glasses to EN166), hearing protection to EN352, safety helmet to EN297, gloves, filter mask and high visibility clothing.

Vehicle Ballast

It is imperative when attaching 'third-party' equipment to a vehicle that the maximum possible stability of the machine and vehicle combination is achieved – this can be accomplished by the utilisation of 'ballast' in order to counter-balance the additional equipment added.

Front weights may be required for rear mounted machines to place 15% of total outfit weight on the front axle for stable transport on the road and to reduce 'crabbing' due to the drag of the cutting unit when working on the ground.

Where a machine works to the side of the tractor rear weights may be required to maintain a reasonable amount of rear axle load on the opposing wheel.

All factors must be addressed in order to match the type and nature of the equipment added to the circumstances under which it will be used - factors that effect stability are;

- Centre of gravity of the tractor/machine combination.
- Geometric conditions, e.g. position of the cutting head and ballast.
- Weight, track width and wheelbase of the tractor.
- Acceleration, braking, turning and the relative position of the cutting unit during these operations.
- Ground conditions, e.g. slope, grip, load capability of the soil/surface.
- Rigidity of implement mounting.

Suggestions to increase stability:

- Increasing rear wheel track - *a vehicle with a wider wheel track is more stable.*
- Ballasting the wheel; it is preferable to use external weights but liquid can be added to around 75% of the tyre volume – water with anti-freeze or the heavier Calcium Chloride alternative can be used.
- Addition of weights – care should be taken in selecting the location of the weights to ensure they are added to a position that offers the greatest advantage.
- Front axle locking, check with tractor manufacturer.

The advice above is offered as a guide for stability only and is not a guide to vehicle strength. It is therefore recommended that you consult your vehicle manufacturer or local dealer to obtain specific advice on this subject, additionally advice should be sought from a tyre specialist with regard to tyre pressures and ratings suitable for the type and nature of the machine you intend to fit.

ATTACHING TO TRACTOR

Fit the machine to the tractor linkage in the standard way, ensuring the correct match of linkage (CAT 2 pins). Check that the top link is in good order and threads are well lubricated - *fine adjustment to height of cut is regulated by the top link*. Use stabilizers to take any free movement out of lower link arms. Before fitting the machine to the tractor linkage you should ensure there is sufficient front weight to ensure the front wheels are always in contact with the ground. This is vital for both safe transportation and stability when turning on slopes.

Before fitting the PTO for the first time, it may be necessary to adjust the length. There should be maximum engagement of the sliding tubes without bottoming at the shortest operation position. See following page for details of shaft measurement and cutting.

To fit the PTO, first clean and grease. Press pins on the yoke and simultaneously push the PTO drive shaft on to PTO shaft of the tractor until pins engage.

The PTO shaft is fitted with a non-rotating safety guard. It should be secured to the machine and tractor with the two retaining chains provided.

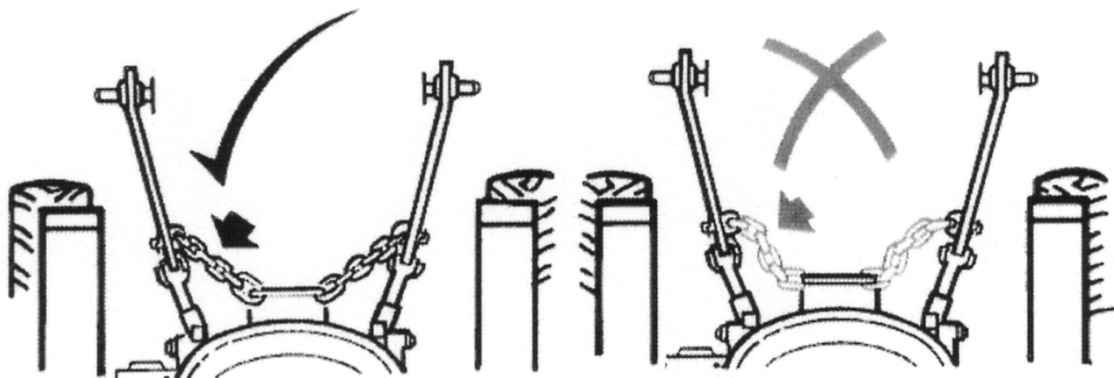

NOTE: Fully tighten check chains and linkage stabilisers to hold the machine rigid – there should not be any sideways movement of the machine when it is attached correctly.

PTO DRIVESHAFT INSTALLATION

The PTO driveshaft attaches between the tractor and the machine gearbox to transfer the power required to run and operate the machine – it is important to achieve the correct shaft length to avoid risk of it ‘bottoming out’ when raising or lowering the machine.

The procedure for measuring and cutting the shaft is as follows:

Measuring the PTO Shaft

With the machine attached to the tractor in the working position measure the horizontal distance ‘A’ from the tractor’s PTO to the input shaft on the machines gearbox and subtract 75mm (3”) – *this figure is the required shaft length.*

Place the fully closed PTO shaft on the ground and measure its overall length, if the shaft is shorter than the required length you can use it without the need to shorten - *providing it allows for a minimum 150mm (6”) overlap when fitted.*

If the shaft is longer subtract the required shaft length plus an additional 75mm (3”) - *the resulting figure is the excess length that will need to be removed from each half of the shaft.*

Cutting the PTO Shaft

NOTE: Check rotation of overrun clutch before cutting the PTO shaft.

Separate the two halves and using the measurement obtained above shorten both the plastic guarding and the inner steel profile tubes of each shaft by this same amount.

De-burr the cut tubes with a file to remove rough or sharp edges and thoroughly clean to remove swarf before greasing, assembling and fitting the shaft.

NOTE: For subsequent use with different tractors the shaft should be measured again to check suitability – *there must be a minimum shaft overlap of 150mm (6”).*

Maintenance

To increase the working life of the PTO shaft it should be periodically checked, cleaned and lubricated.

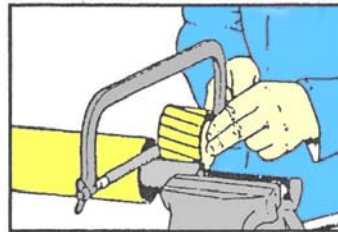
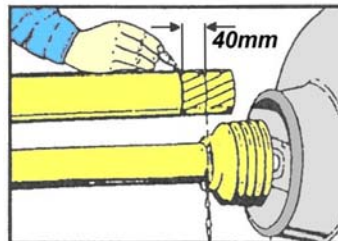
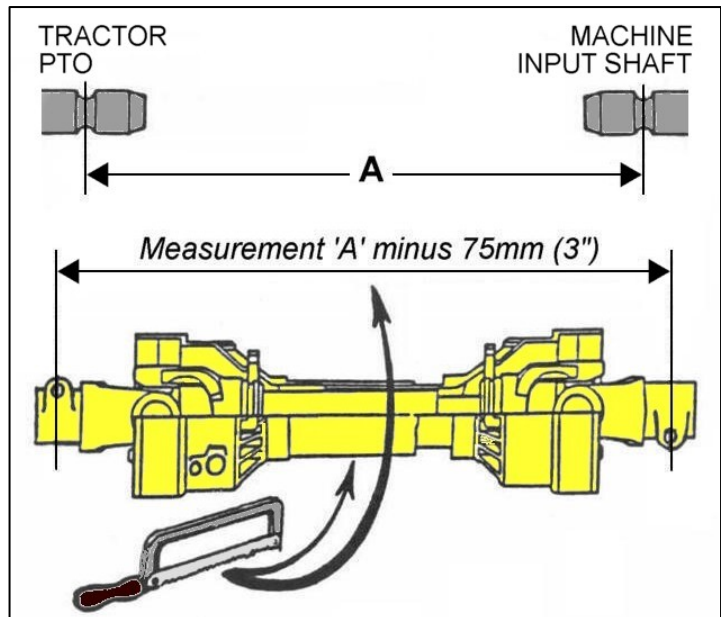

SETTING UP & ADJUSTMENT

Height Adjustment

For major adjustment to the height of cut; reposition the two side plates attached to the rear roller. Fine adjustment to cut is achieved by lengthening or shortening the top link of the tractor.

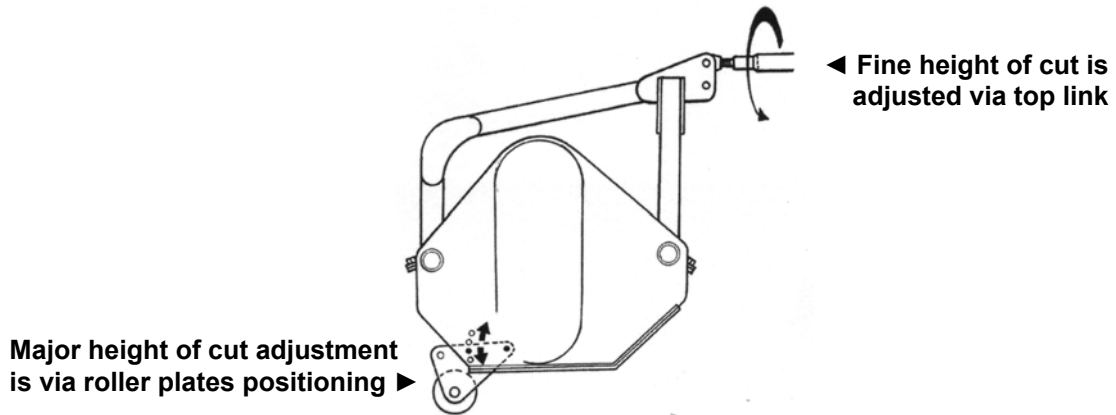

Mechanical Offset

The linkage 'A' frame can be slid along the tube to a variety of settings from centrally positioned up to fully offset by slackening the clamping bolts, sliding the 'A' frame to the required position then re-tighten the bolts. NOTE: Remember to regularly check that these bolts are fully tight.

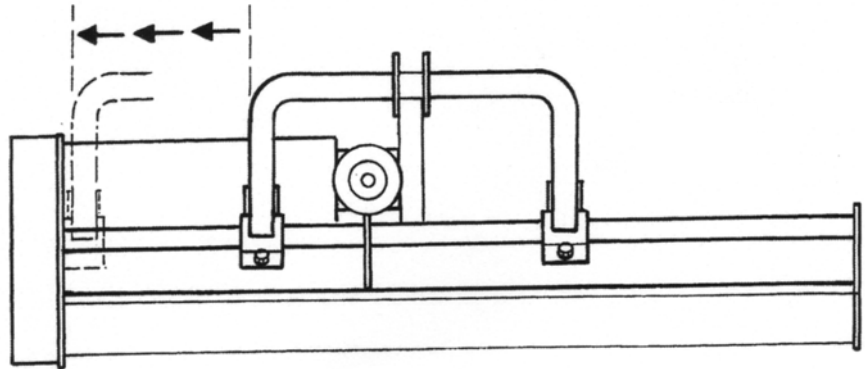

Hydraulic Offset (Optional)

The machine can be moved into a variety of settings from the central position to fully offset by operation of the tractors' external spool valve. Lubricate the sliding tubes with grease/oil to prolong the life of the bushes. To reduce strain on the drive line ensure to operate the PTO in a straight line.

Front Linkage Mounting

Simply remove the clamping bolts and revolve the standard 'A' frame through 180 degrees so the linkage mounting pins are facing the rear of the mower – the hydraulic 'A' frame is double sided.

Tractor front PTO's have no standard direction of rotation so it may be necessary to turn the gearbox through 180 degrees (top to bottom) to compensate for this irregularity. It is vital that the rotor rotates in the right direction to ensure correct cutting.

Wheel Kits (Optional)

Optional wheel kits are available for height control; these are recommended for all front mounted machines on both standard and hydraulic models.

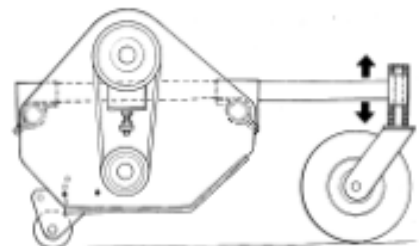

540 or 1000 RPM

If the tractor only has a 540RPM PTO output speed it is possible to compensate by swapping the top drive pulley onto the rotor and rotor pulley to the top drive shaft – in this way the smaller pulley will be driving the larger pulley and will therefore act as a reducer (*Refer to diagrams below*).

CAUTION: Never operate the PTO at 1000 RPM with the larger pulley driving the smaller rotor pulley – this will drive the rotor at a higher speed and will result in severe damage to the machine.

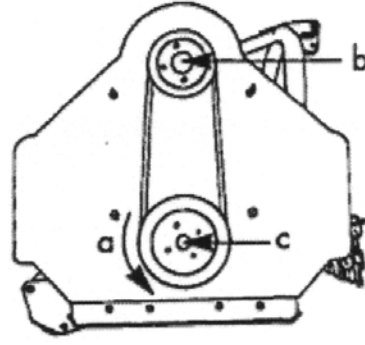
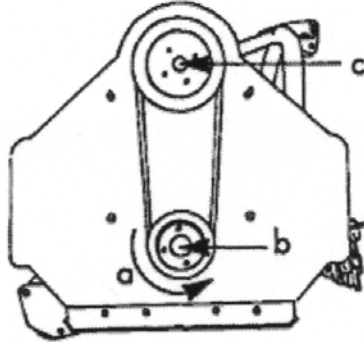

Position of pulleys for 540RPM

Position of pulleys for 1000RPM

a) Rotation Anti-Clockwise b) 190mm Shaft Pulley c) 250mm Shaft Pulley

OPERATION

Engage the PTO only when the tractor engine is at low revs to prevent shock damage to machine components. Slowly increase the engine revs to achieve the standard 1000/540 RPM PTO speed as indicated by the machines speed decal.

CAUTION: If at any time serious vibration occurs, stop the engine immediately and following all safety precautions check the rotor for missing or damaged flails. Do not attempt to use the machine until the cause is found and rectified.

To start work, lower the machine to the ground carrying all its weight on the rear roller or wheels allowing the machine to follow the contours of the ground. Select a sensible forward speed bearing in mind the density of growth, the terrain, and the available horsepower, taking extra care when turning, particularly on slopes. When turning it is not necessary to lift the machine off the ground but instead allow sufficient room to turn in a large radius. The machine only needs to be raised when turning a tight corner or reversing over dense undergrowth.

Quality of finish is determined by the forward speed i.e. a slow speed will produce a high quality of cut, whereas faster forward speeds are used when high output is the first priority.

When cutting in extreme conditions or when small stumps, stones and other such solid objects are likely to be found it is recommended the operator reduces the engine revs to allow the flails to pivot more easily when striking solid objects, and proceed with caution.

ROTOR CARE

Always operate at the correct PTO speed, 540/1000 r.p.m.

Always inspect the condition of flails and bolts on a very regular basis.

Always replace bushes, bolts and nuts when replacing flails.

Always use genuine flails, bolts and nuts – *the flails and bolts are made to a high standard from high tensile steel that is fully heat treated and subjected to rigorous testing under stringent conditions to comply with our rigid quality control requirements.*

Never operate with bolts loose or flails missing.

Never change to a different spec or type of flail, this will immediately put the rotor out of balance.

Never engage rotor at high PTO speeds.

Remember, the rotor is highly complex and expensive to manufacture – treat it with care.

WARNING!

Rotor is balanced to be run at PTO speed - do not operate above or below this speed. Optimum rotor speed 2200 RPM

WARNING!

Never carry out any servicing or maintenance work without first disengaging the PTO and stopping the tractor.

SERVICING & MAINTENANCE

Gearbox

- Before first use check gearbox oil level, thereafter check every 8 hours.
- After the first 50 hours drain and replace the gearbox oil, thereafter annually. Replace with EP90.
- Regularly inspect gearbox seals. If oil is leaking replace immediately.
- Check that gearbox bolts are fully tightened, and secured with loctite.

CAUTION: Check that all gearbox bolts remain tight. When the machine is new there is a 'bedding in' period when very frequent checking is important.

CAUTION: It is imperative the screws are checked on the pulley taper locks - *once 'bedded in', Loctite compound may prove useful.*

WARNING: Never carry out any servicing or maintenance work without first disengaging the PTO and stopping the tractor.

Flail Rotor

- Grease all bearings daily.
- Check there is no wrapping of string, plastic, grass or other debris on rotor shaft and rear roller bearing.
- Check the condition of flails and ensure all retaining bolts are tight. When flails are replaced care must be taken to maintain balance of the rotor shaft, do not change to a different type.
- Check flail retaining bolt and nut for tightness, 160lb.ft – 200Nm.
- Never operate with any flails missing, this will cause severe vibration and lead to rapid bearing wear and quickly cause the hood to crack.
- Blunt flails leave an untidy finish and absorb excessive power, when re-sharpening always wear protective clothing and goggles.
- When flails are showing severe wear, damage or cracking, they must be replaced immediately. Never attempt to weld the flails as this will make them very brittle and thus extremely dangerous. Do not take risks with the cutting flails, if in doubt replace.
- When replacing flails always replace the bolts and nuts with new ones.
- Regularly check that all bearing bolts are tight.
- It is imperative the screws are checked on the taper locks (*once bedded in loctite glue may prove useful*).

Greasing

Grease all points indicated on a daily basis ►
Grease rotor bearing and rear roller points at least every 8 hours and especially after washing the machine.

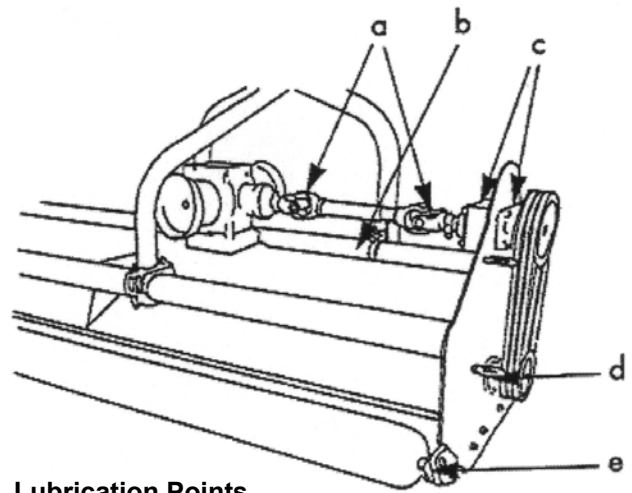

Lubrication Points

PTO Maintenance

Dismantle and clean PTO sliding surfaces and re-grease universal joints.

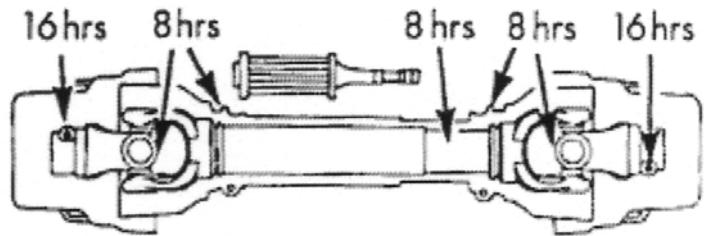

Regular Maintenance

- Check the condition of drive belts, ensuring they are aligned and properly tensioned to avoid any unnecessary belt wear.
- Remove both guards for access when tensioning belts; ensure belts are running in line after adjustment.
- Check there is no wrapping of string, plastic, grass or other debris on rear roller.

NOTE: The pulleys are fitted with taper locks which have 7 screws to tighten and 3 holes to aid removal in the pulley centers.

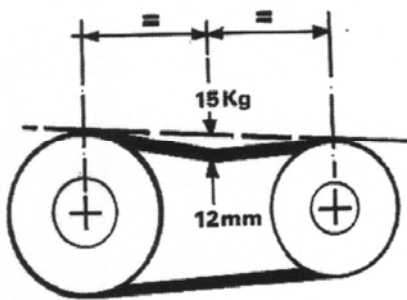

Drive Belt Tensioning

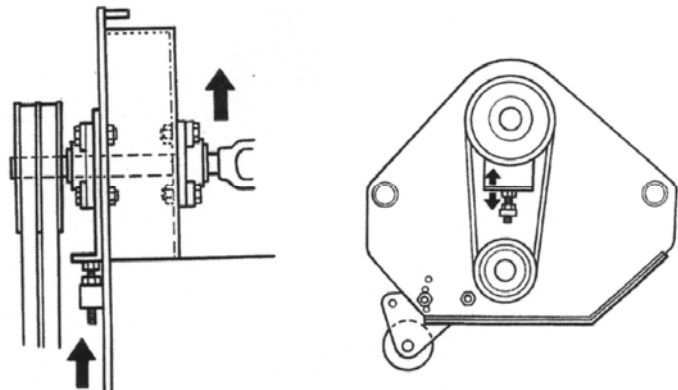

Skids

When operating on abrasive soils, particularly in stubbles and similar conditions with thin ground cover, excessive skid wear may be expected. To provide extra protection and prolong the life of skids, special hard facing rods can be used.

Storage

At the end of the season before storing, thoroughly wash the machine off, removing all traces of grass and dirt. Great care must be taken when washing with high-pressure hoses, do not hold the water jet close to the paintwork. Use steam cleaners with caution and be sure to remove all detergents to avoid any discoloring or damage to paint. Grease all grease points until fresh grease shows. Store PTO shaft and drive belts in a dry place.

Transportation

Please observe Public Highway Regulations, concerning transport of machines and securely attach a registration/lighting board. Take care when travelling over rough ground to avoid bouncing the machine on the tractor linkage, causing unnecessary strain. Warning always be aware of the extra width hazard of 'off-set' machines.

Gearbox

Gearbox oil level should be checked on a daily basis prior to work; the oil level plug is the lower centre plug located on the aluminium end plate of the gearbox, *see opposite*.

Ensure machine is parked on a level site when checking gearbox oil level.

Oil level is correct when it is inline with the level plug orifice; top up oil if the level is low to a point where the oil begins to seep out from the level plug hole.

Oil Capacity = 1.8 Litre

Oil Type: EP90

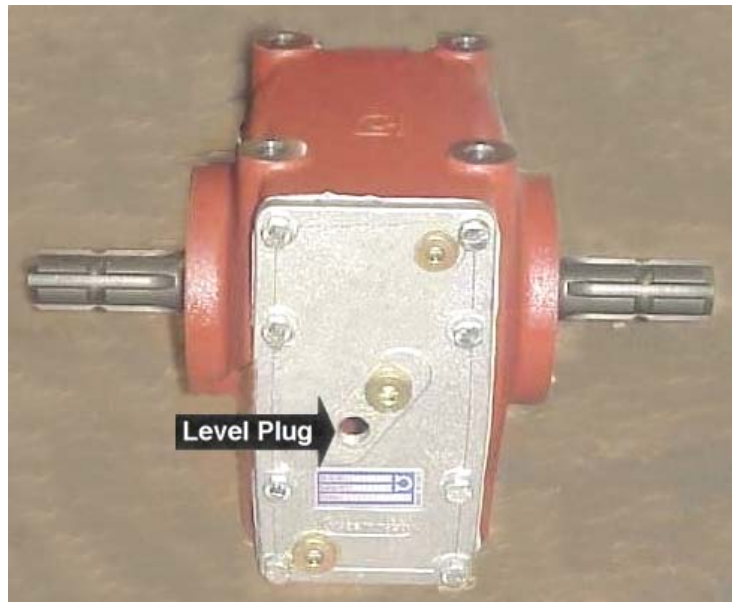

Servicing Checklist (*refer to relevant sections for full details*)

Regularly

Gearbox: Inspect seals, check bolts for tightness.

Flail rotor: check bolts for tightness, check condition of flails, check retaining bolts for tightness, check rotor bearing bolts for tightness.

Daily

Maintain correct belt tension.

Check gearbox oil level.

Grease PTO shaft.

Grease all points as shown in diagram.

Annually

Drain and replace gearbox oil with EP90 (Gearbox Capacity 1.8L).

Torque Settings

The torque figures given are recommended maximum settings only.

Size:	Tensile strength:	Description:	Torque setting (Nm.)
M8	12.9	Pulley clamps	45
M10	8.8	General fasteners	65
M12	8.8	General fasteners	114
M16	8.8	Roller plate bolts	280
M14	10.9	Flail bolts	200
M24	8.8	Head stock bolts	950

TROUBLESHOOTING

Problem	Cause	Solution
Gearbox Overheating	Oil level incorrect Oil grade incorrect Implement overloaded Wrong P.T.O. speed	Check oil level Check oil grade Reduce forward speed Ensure tractor P.T.O. speed matches implement.
Excessive Belt Wear	Belt and Pulley condition Pulley Alignment Incorrect belt tension Overloading of implement	Replace if necessary Check Alignment Tension belts to spec. Reduce forward speed or increase height of cut.
PTO wear / UJ failure	Working angle too great Shaft incorrect length i.e. Bottoming out Lack of maintenance	Reduce offset of implement Resize P.T.O. shaft as recommended Grease P.T.O. shaft as recommended.
Cut quality	Flails worn Rotor speed/Direction Crop condition.	Replace worn flails Check tractor P.T.O. speed Look for suitable conditions.
Rotor bearing failure	Rotor out of balance Wire/string in bearing Lack of maintenance Water in bearing.	See rotor vibration Replace bearings Re-balance/replace rotor Remove debris.

MERLIN*Xtreme*
2000 / 2500 / 2800
PARTS SECTION



MAIN ASSEMBLY

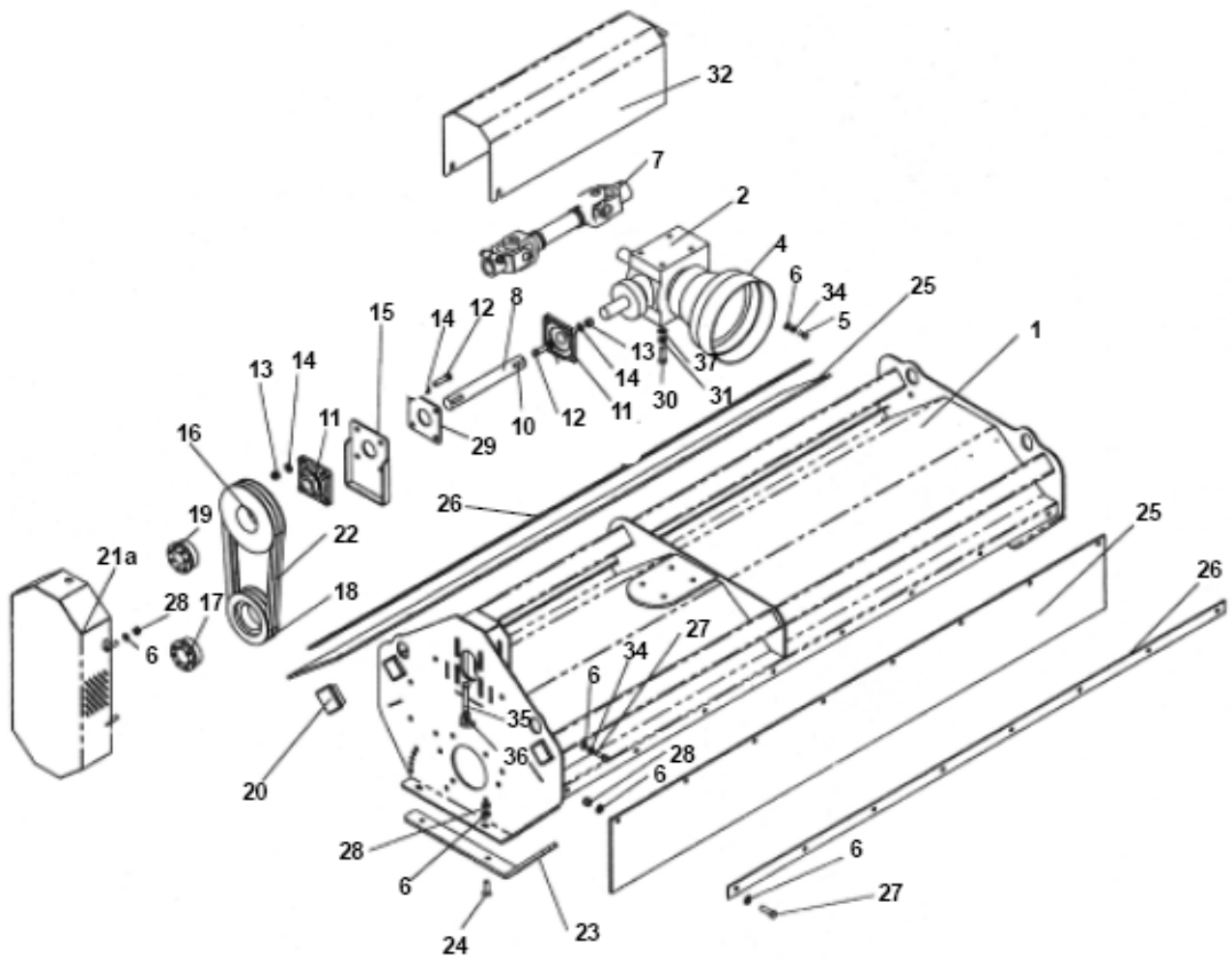

MAIN ASSEMBLY

REF.	PART No.	DESCRIPTION	DESCRIPTION	DESCRIPTION	DESCRIPTION
		ENGLISH	FRENCH	GERMAN	DANISH
1	N/A	Body	Caisse	Korper	Krop
2	5770009	Gearbox	Multiplicateur	Getriebasten	Gearkasse
4	5770106	Guard	Protecteur	Schutz/Deckel	Beskyttelse/Daeksel
5	2770418	Bolt	Boulon	Bolzen	Bolt
6	2770434	Washer	Rondelle	Spannscheibe	Spaendeskiye
7	5770040	Shaft	Arbre	Welle	Aksel
	5770115	Shaft Q2800	Arbre	Welle	Aksel
8	1772211A	Shaft	Arbre	Welle	Aksel
10	4772229	Key	Clavette	Nut	Not
11	4770933EC	Bearing	Palier – Roulement	Lager	Leje
12	2770423	Bolt	Boulon	Bolzen	Bolt
13	2440447	Nut	Ecrou	Mutter	Motrik
14	2770454	Washer	Rondelle	Spannscheibe	Spaendeskiye
15	1771513A	Bracket	Support – Etier	Konsole	Konsol
16	4770920	Pulley(250mm)	Poulie	Riemenscheibe	Remskive
17	4770922	Taper Lock	Conique de verrouillage	Kegel Sperre	Koniska lase
18	4770918	Pulley(190mm)	Poulie	Riemenscheibe	Remskive
19	4770921	Taper Lock	Conique de verrouillage	Kegel Sperre	Koniska lase
20	8777516	Cap	Protecteur	Schutz/Deckel	Beskyttelse/Daeksel
21	1772231B	Guard	Protecteur	Schutz/Deckel	Beskyttelse/Daeksel
22	4770843	Belt	Ceinture	Gurtel	Baelte
23	1772309	Skid	Patin	Stutzkufen	Glideskinne
24	2770422	Bolt	Boulon	Bolzen	Bolt
25	8400201	Rubber 2m	Caoutchouc	Gummi	Gummi
	8400200	Rubber 2.5m	Caoutchouc	Gummi	Gummi
	8400199	Rubber 2.8m	Caoutchouc	Gummi	Gummi
26	1772290	Bar 2m	Barre	Halter	Aksel
	1772291	Bar 2.5m	Barre	Halter	Aksel
	1772310	Bar 2.8m	Barre	Halter	Aksel
27	2770396	Bolt	Boulon	Bolzen	Bolt
28	2770412	Nut	Ecrou	Mutter	Motrik
29	1771520A	Plate	Plaque	Platte	Plade
30	2770493	Bolt	Boulon	Bolzen	Bolt
31	2770457	Washer	Rondelle	Spannscheibe	Spaendeskiye
32	1772256B	Cover – 2m	Protecteur	Schutz/Deckel	Beskyttelse/Daeksel
	1772268A	Cover – 2.5 & 2.8m	Protecteur	Schutz/Deckel	Beskyttelse/Daeksel
34	2770469	Washer	Rondelle	Spannscheibe	Spaendeskiye

ROTOR & ROLLER ASSEMBLY

REF.	PART No.	DESCRIPTION	DESCRIPTION	DESCRIPTION	DESCRIPTION
		ENGLISH	FRENCH	GERMAN	DANISH
1	1772307	LH plate	Plaque	Platte	Plade
2	1772307R	RH plate	Plaque	Platte	Plade
3	SA 02006	Roller assembly 2m	Rouleau	Hinterlaufwaize	Bagvalse
	SA 02005	Roller assembly 2.5m	Rouleau	Hinterlaufwaize	Bagvalse
	SA 02007	Roller assembly 2.8m	Rouleau	Hinterlaufwaize	Bagvalse
9	1772305	Shaft	Arbre	Welle	Aksel
10	4770872	Bearing	Palier – Roulement	Lager	Leje
11	2771109	Circlip	Circlip	Sicherungsring	Lasering
12	2777512	Circlip	Circlip	Sicherungsring	Lasering
13	1772306	Cover	Protecteur	Schutz/Deckel	Beskyttelse/Daeksel
14	2770468	Grease Nipple	Graisreur	Schmiernippel	Smorenippel
15	2770425	Bolt	Boulon	Bolzen	Bolt
16	2770447	Nut	Ecrou	Mutter	Motrik
17	2770454	Washer	Rondelle	Spannscheibe	Spaendskive
18	4770891	Bearing	Palier – Roulement	Lager	Leje
19	2771610	Circlip	Circlip	Sicherungsring	Lasering
20	1777850	Washer	Rondelle	Spannscheibe	Spaendskive
21	2770461	Bolt	Boulon	Bolzen	Bolt
22	1777312A	Cover	Protecteur	Schutz/Deckel	Beskyttelse/Daeksel
24	7770699	Flail	Fleau	Schlegel	Slagle
25	1777721	Bush	Bague	Buchse	Bosning
26	2770600	Bolt	Boulon	Bolzen	Bolt
27	05.968.06	Nut	Ecrou	Mutter	Motrik
29	2770397	Bolt	Boulon	Bolzen	Bolt
30	2770467	Grease Nipple	Graisreur	Schmiernippel	Smorenippel
31	1772303A	Housing	Carter	Gehause	Hus
32	4771122	Seal	Rondelle	Spannscheibe	Spaendskive
33	2771611	Circlip	Circlip	Sicherungsring	Lasering
34	4770892	Bearing	Palier – Roulement	Lager	Leje
35	4770893	Sleeve	Contre-ecrou	Nylon mutter	Lasemotrik
36	1772302A	Housing	Carter	Gehause	Hus
	2770398	C/Sink Bolt	Lavabo Bolt	Spulbecken Bolt	Synker Bolt
37	1772311A	Seal Housing	Sceau de logement	Seal Housing	Seal Boliger
38	4771511	Washer	Rondelle	Spannscheibe	Spaendskive
39	2770443	Bolt	Boulon	Bolzen	Bolt
40	1772298A	2m Rotor assembly	Rotor	Rotor	Rotor
	1772299A	2.5m Rotor assembly	Rotor	Rotor	Rotor
	1772301A	2.8m Rotor assembly	Rotor	Rotor	Rotor
41	2770450	Bolt	Boulon	Bolzen	Bolt
42	2770436	Washer	Rondelle	Spannscheibe	Spaendskive
43	2770417	Nut	Ecrou	Mutter	Motrik
44	180470	Spacer	Entretoise	Distanzscheibe	Afstandsbosning

HEADSTOCK ASSEMBLY

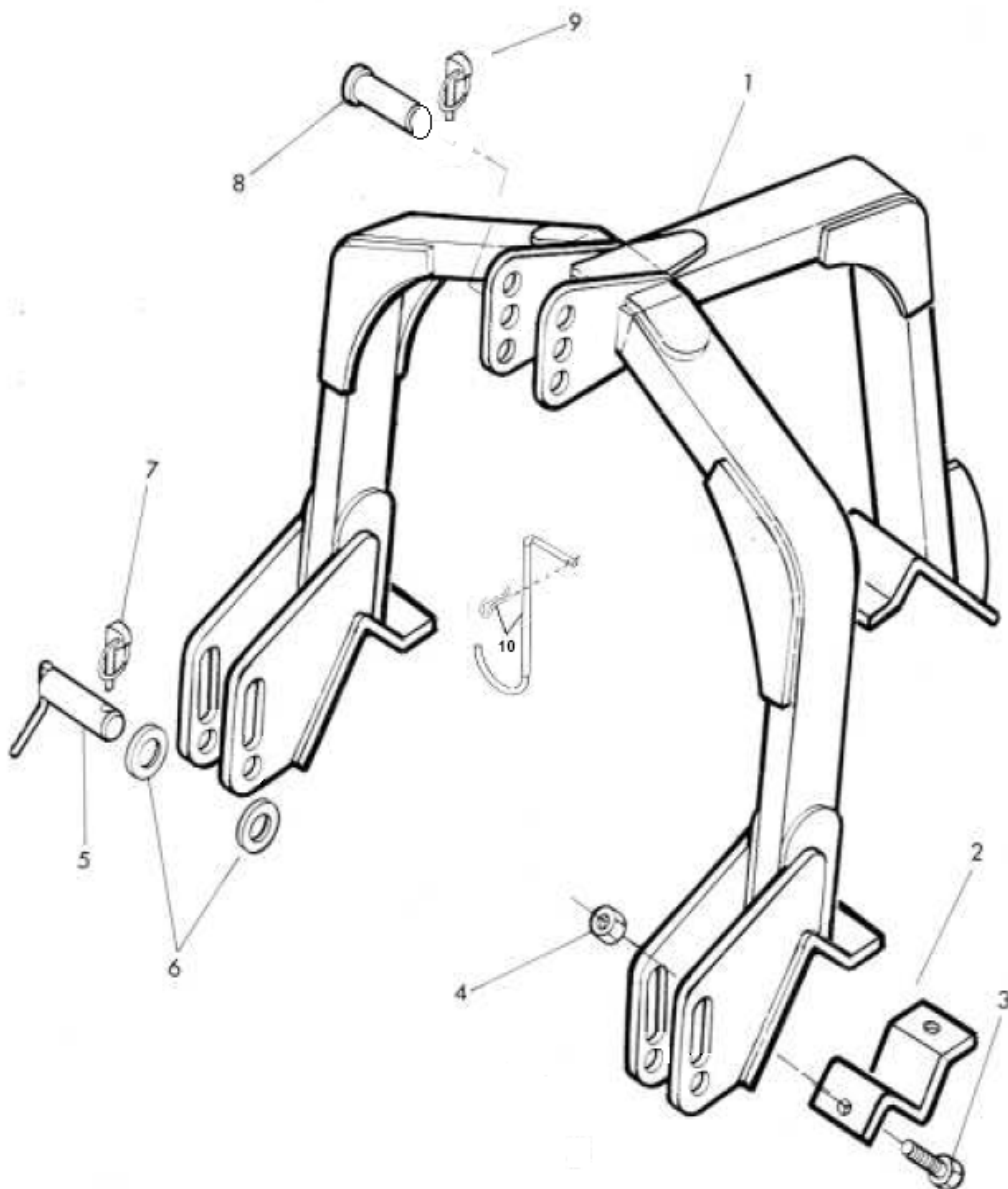

HEADSTOCK ASSEMBLY

REF.	PART No.	DESCRIPTION	DESCRIPTION	DESCRIPTION	DESCRIPTION
		ENGLISH	FRENCH	GERMAN	DANISH
1	1772265	Standard Headstock	Poupee	A-rahmen	A-ramme
2	1772266	Front Clamp	Bride de retenue	Halter	Holder
	1772267A	Rear Clamp	Bride de retenue	Halter	Holder
3	2770403	Bolt	Boulon	Bolzen	Bolt
4	2770414	Nut	Ecrou	Mutter	Motrik
5	6310208	Pin	Goupille	Bolzen	Bolt
6	2770470	Washer	Rondelle	Spannscheibe	Spaendeskiye
7	00.372.01	Pin	Goupille	Bolzen	Bolt
8	6310203	Pin	Goupille	Bolzen	Bolt
9	00.372.01	Pin	Goupille	Bolzen	Bolt
10	1777434	PTO Support	Support – Etrier	Konsole	Konsol
	6310194	Clip	Attache	Spannstuck	Spaendeband

HYDRAULIC HEADSTOCK ASSEMBLY

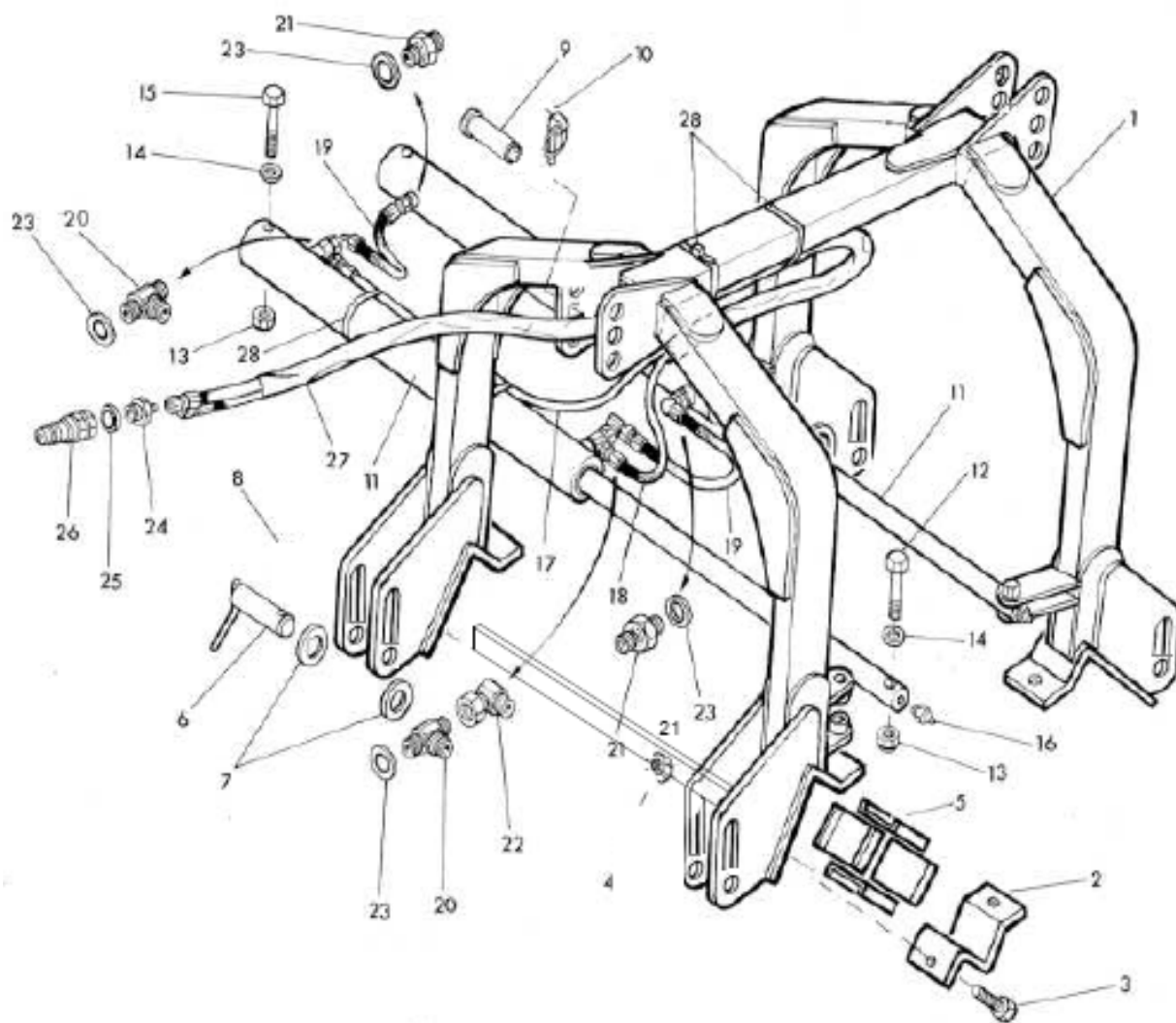

HYDRAULIC HEADSTOCK ASSEMBLY

REF.	PART No.	DESCRIPTION ENGLISH	DESCRIPTION FRENCH	DESCRIPTION GERMAN	DESCRIPTION DANISH
1	1772270	Hydraulic Headstock	Poupee	A-rahmen	A-ramme
2	1772271A	Clamp	Bride de retenue	Halter	Holder
3	2770519	Bolt	Boulon	Bolzen	Bolt
4	2770414	Nut	Ecrou	Mutter	Motrik
5	4600120	Wear Pad	Porter Pad	Wear Pad	Baer Pad
6	6310208	Pin	Goupille	Bolzen	Bolt
7	2770470	Washer	Rondelle	Spannscheibe	Spaendeskiye
8	00.372.01	Pin	Goupille	Bolzen	Bolt
9	6310203	Pin	Goupille	Bolzen	Bolt
	1777434	PTO Support	PTO Soutien	PTO Unterstuetzung	PTO-stotte
	6310194	Clip	Attache	Spannstuck	Spaendeband
11	3580650	Ram - 2m	Verin	Hydr Zylinder	Hydr Cylinder
	3580663	Ram - 2.5m & 2.8m	Verin	Hydr Zylinder	Hydr Cylinder
	3570650T,W,HP	Seal Kit	Kit de Joints	Dichtungssetz	Degl Kit
12	2770424	Bolt	Boulon	Bolzen	Bolt
13	2770417	Nut	Ecrou	Mutter	Motrik
14	2770436	Washer	Rondelle	Spannscheibe	Spaendeskiye
15	2770471	Bolt	Boulon	Bolzen	Bolt
16	2770511	Grease Nipple	Graisser	Schmiernippel	Smorenippel
17	3760261	Hose	Flexible	Schlauch	Slange
18	3760262	Hose	Flexible	Schlauch	Slange
19	3760260	Hose	Flexible	Schlauch	Slange
20	3460100	Adaptor	Raccord	Brustnippel	Nippel
21	3360080	Adaptor	Raccord	Brustnippel	Nippel
22	3460107	Adaptor	Raccord	Brustnippel	Nippel
23	3260070	Washer	Rondelle	Spannscheibe	Spaendeskiye
24	3360074	Washer	Rondelle	Spannscheibe	Spaendeskiye
25	3260072	Seal	Joint	Oldichtung	Pakning
26	3750153	QR Coupling	Accouplement	Kupplung	Kobling
27	3870500	Sleeve	Manchon	Armel	Aerme
28	8770639	Tie	Cravate	Band	Binde

WHEEL KIT ASSEMBLY (HYDRAULIC HEADSTOCK)

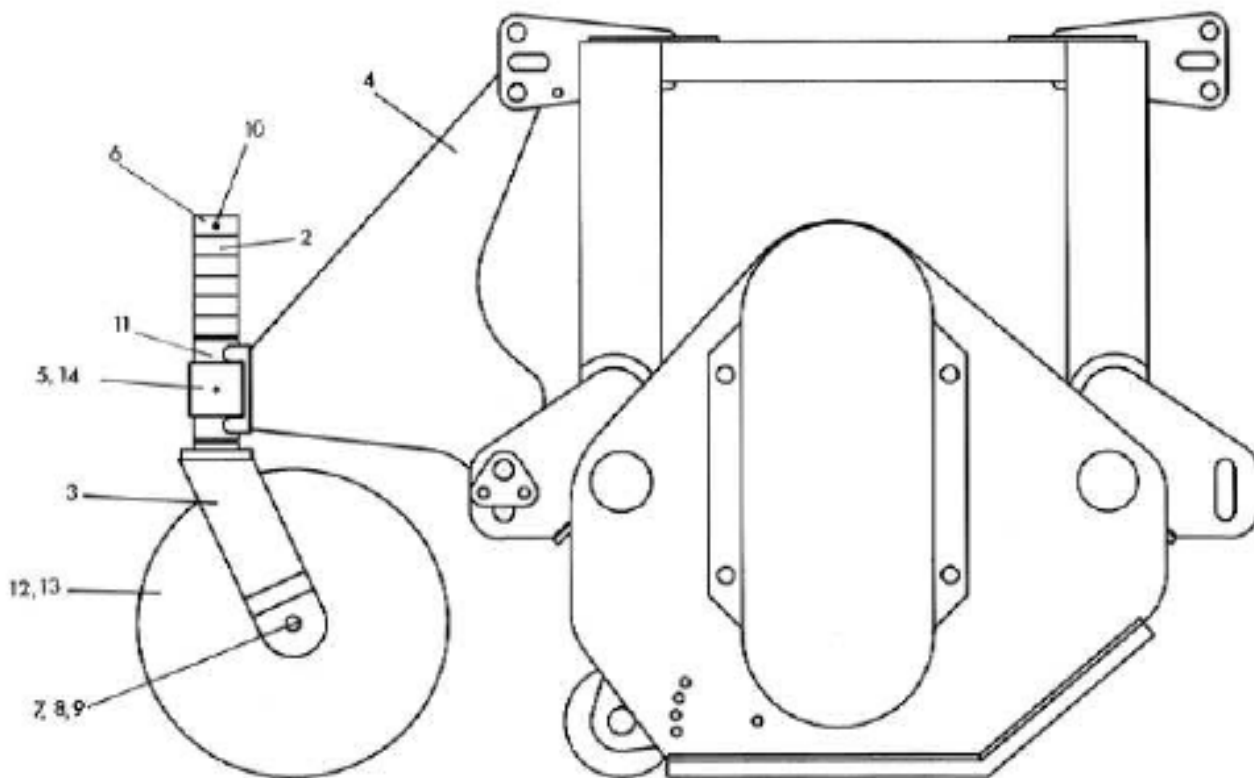

REF.	PART No.	DESCRIPTION ENGLISH	DESCRIPTION FRENCH	DESCRIPTION GERMAN	DESCRIPTION DANISH
	OPT 0009	Wheel kit	Ensemble roué	Rader	Hjul
2	1770393	Spacer	Entretoise	Distanzscheibe	Afstandsbosning
3	1770394	Wheel Yoke	Joug Roue	Rad Joch	Hyulet ag
4	1777449	Frame	Cadre	Rahmen	Ramme
5	1777450	Beam	Faisceau	Strahl	Strale
6	1777700	Bush	Bague	Buchse	Bosning
7	2770409	Nut	Ecrou	Mutter	Motrik
8	2770517	Washer	Rondelle	Spannscheibe	Spaendeskive
9	2770538	Bolt	Boulon	Bolzen	Bolt
10	2770479	Roll Pin	Goupille	Bolzen	Bolt
11	4600127-A	Bush	Bague	Buchse	Bosning
12	6770646	Wheel	Roue	Rad	Hjulet
13	6770676	Hub	Moyeu	Nabe	Nav
14	1777325	Clamp Plate	Plaque	Platte	Plade

PTO SHAFT ASSEMBLY

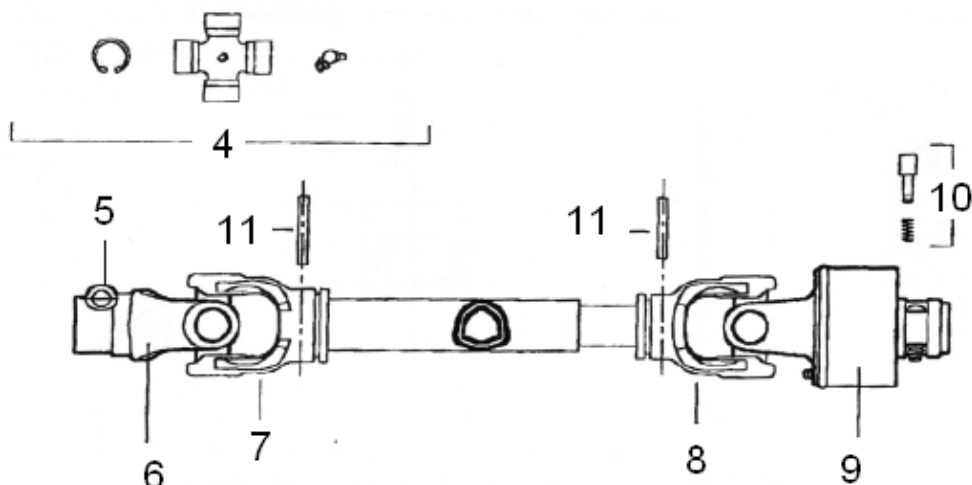
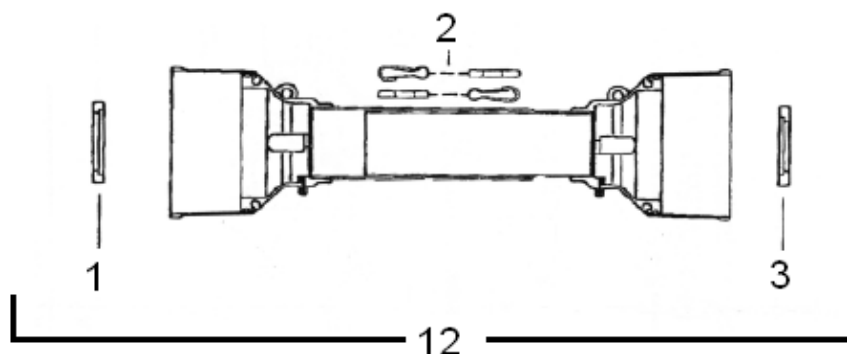

REF.	PART No.	DESCRIPTION ENGLISH	DESCRIPTION FRENCH	DESCRIPTION GERMAN	DESCRIPTION DANISH
	5780076	PTO shaft assy (R/M)	Ensemble arbre de prise de force	Gelenkwelle	Pto-aksel
	5780078	PTO shaft assy (F/M)	Ensemble arbre de prise de force	Gelenkwelle	Pto-aksel
1	4770815	Outer Bearing	Exterieur Portant	Aubenlager deckle	Udvendige baerende
2	5771020	Chain	Chaine - chéinette	Kette	Kaede
3	4770814	Inner Bearing	Palier-Roulement	Lager	Leje
4	5771301	Cross Journal	Portee d'arbre transversale	Kreuzgarnitur	Kardankryds
5		Release Pin	Broches de sortie	Release Pin	Release Pin
6	5771299	QR Yoke	QR joug	QR joch	QR ag
7	5770095	Tube Yoke	Tube joug	Tube joch	Tube ag
8	5770096	Tube Yoke	Tube joug	Tube joch	Tube ag
9	5772321	Overrun Clutch (R/M)	Depassement d'embrayage	Uberschreitung kupplung	Overskridelsa kobling
9	5772321L	Overrun Clutch (F/M)	Depassement d'embrayage	Uberschreitung kupplung	Overskridelsa kobling
10	5771322	Taper Pin	Conique broches	Kegel-polig	Koni ske pin
11	2770542	Roll Pin	Goupille	Bolzen	Bolt
12	5772262	Complete Guard	Garde Complete	Komplette wache	Komplet afskaermning

CROSS SHAFT ASSEMBLY

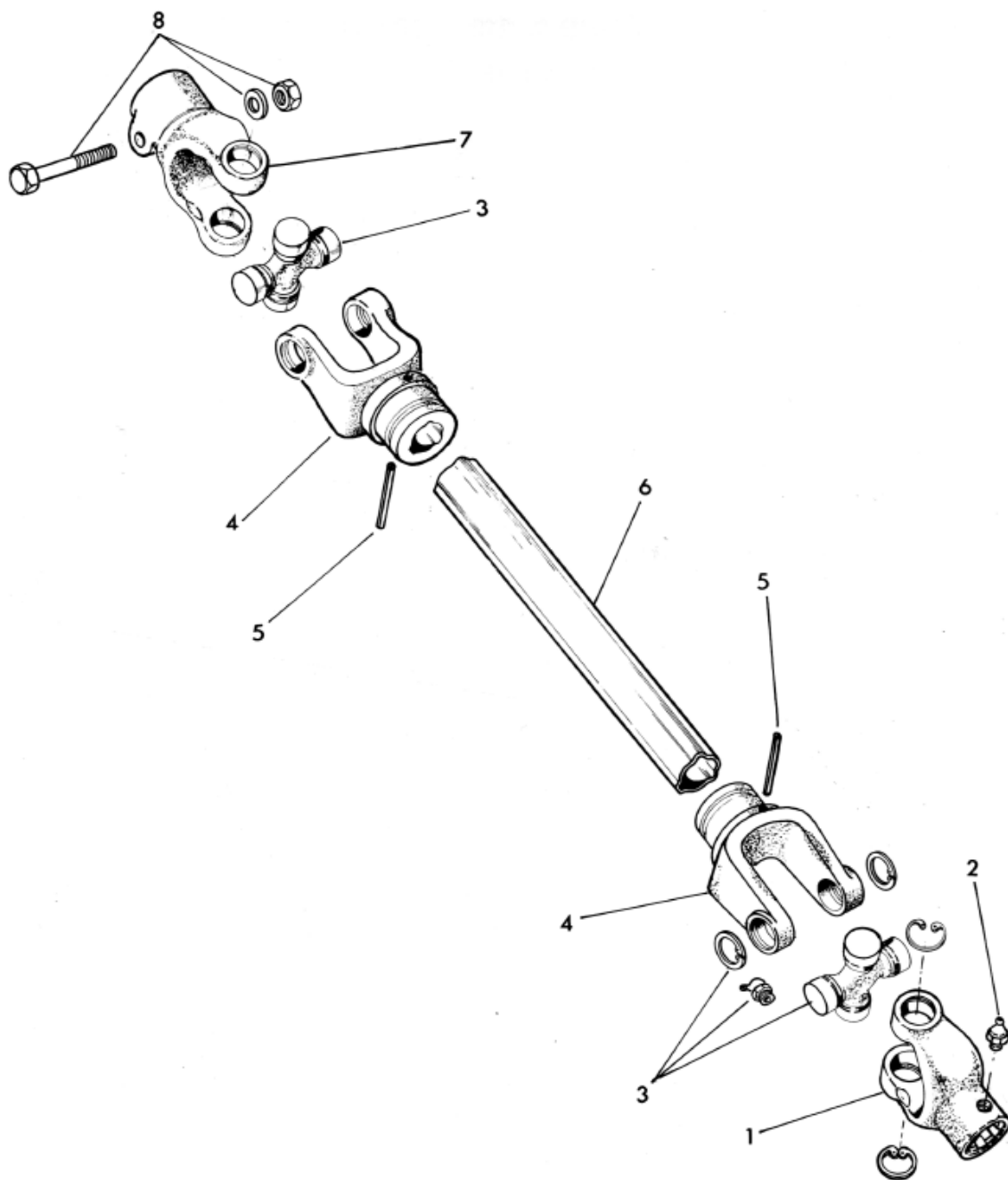

CROSS SHAFT ASSEMBLY

REF.	PART No.	DESCRIPTION ENGLISH	DESCRIPTION FRENCH	DESCRIPTION GERMAN	DESCRIPTION DANISH
	5770040	Shaft - 2000 & 2500	Arbre	Welle	Akslen
	5770115	Shaft - 2800	Arbre	Welle	Akslen
1	5772279	6 Spline Yoke	Spline joug	Spline joch	Spline ag
2	2770467	Grease Nipple	Graisneur	Schmiernippel	Smorenippel
3	5770113	Cross Journal	Portee d'arbre transversale	Kreuzgarnitur	Kardankryds
4	5772274	Tube Yoke	Tube	Schlauch	Slange
5	2770527	Pin	Goupille	Bolzen	Bolt
6	N/A	Tube - 200mm	Tube	Schlauch	Slange
	N/A	Tube - 300mm	Tube	Schlauch	Slange
	N/A	Tube - 400mm	Tube	Schlauch	Slange
7	5772271	Clamp Yoke - 35mm	Bride de retenue	Halter	Holder
	2770424	Bolt	Boulon	Bolzen	Bolt
8	2770417	Nyloc Nut	Ecrou	Mutter	Motrik
	2770436	Flat Washer	Rondelle	Spannscheibe	Spaendeskrive

GEARBOX ASSEMBLY

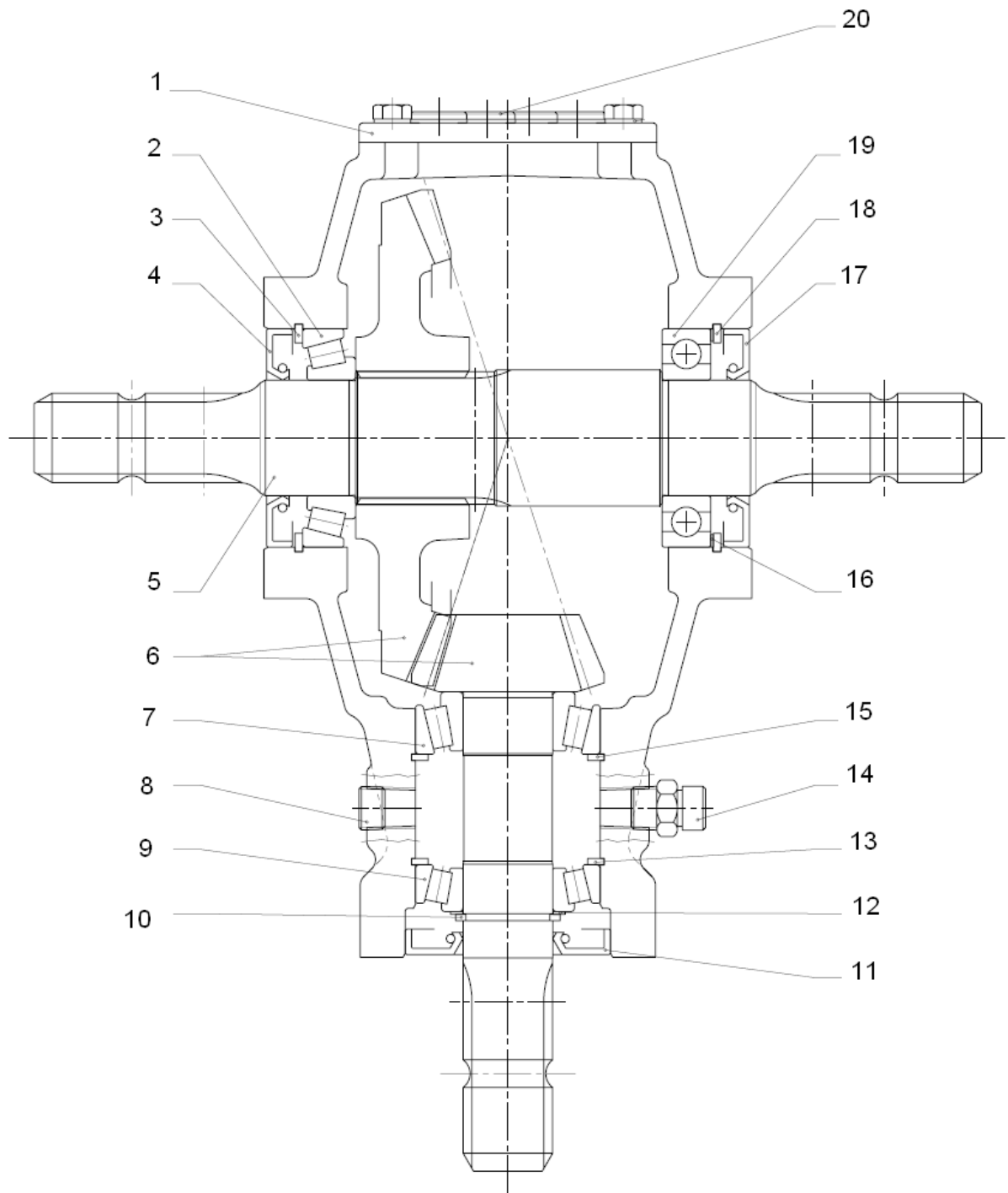

GEARBOX ASSEMBLY

REF.	PART No.	DESCRIPTION ENGLISH	DESCRIPTION FRENCH	DESCRIPTION GERMAN	DESCRIPTION DANISH
	5770009	Gearbox Assembly	Ensemble multiplicateur	Getriebekasten	Gearkasse
1	5772296	Cover	Proteceteur	Schutz/Deckel	Beskyttelse/Daeksel
2	5772341	Bearing	Palier – Roulement	Lager	Leje
3	5772447	Circlip	Circlip	Sicherungsring	Lasering
4	5772343	Seal	Joint	Oldichtung	Pakning
5	5772297	Shaft	Arbre	Welle	Akslen
6	5772344	Gearset	Vitesse	Getriebe	Gear
7	4771606	Bearing	Palier – Roulement	Lager	Leje
8		Plug	Plug	Plug	Plug
9	5771435	Bearing	Palier – Roulement	Lager	Leje
10	5772299	Circlip	Circlip	Sicherungsring	Lasering
11	4771124	Oil Seal	Joint	Oldichtung	Pakning
12	N/A	Shims	Cales	Passplatten	Shims
13	5772348	Circlip	Circlip	Sicherungsring	Lasering
14	5771607	Breather	Bouchon	Schraube	Prop
15	5772348	Circlip	Circlip	Sicherungsring	Lasering
16	N/A	Shims	Cales	Passplatten	Shims
17	5772343	Oil Seal	Joint	Oldichtung	Pakning
18	5772347	Circlip	Circlip	Sicherungsring	Lasering
19	5772340	Bearing	Palier – Roulement	Lager	Leje
20	5777205	Plug	Plug	Plug	Plug
	1777602	Rear Shaft Guard	Arbre arriere garde	Hinteren Schacht wache	Bageste aksel vegt

SAFETY & INFORMATION DECALS



1



2



3



4



5



6



7



8



9



10

REF.	PART No.	DESCRIPTION
1	8770363	Decal - Read manual
2	8770367	Decal - Read manual
3	8770357	Decal - Keep safe distance when machine is running
4	8770360	Decal - Stay clear of mower flails
5	8770362	Decal - Escaping fluid
6	8770306	Decal - Keep bolts tight
7	8770358	Decal - Shut off engine, remove key
8	8770323	Decal - Recommended PTO speed 1000RPM
9	8770305	Decal - Recommended PTO speed 540RPM
10	8770322	Decal - Grease point
11	8770356	Decal - Do not remove/open guard (not shown)
12	8770305	Decal - Check belt tension (not shown)

IDENTIFICATION DECALS



1290804



1290805



1290806



1290807



McConnel Limited, Temeside Works, Ludlow, Shropshire SY8 1JL. England.
Telephone: 01584 873131. Facsimile: 01584 876463. www.mcconnel.com