

Publication 755  
August 2013  
Part No. 22675.55  
Revised: 19.06.14



# MAGNUM

## 1.6M / 1.9M / 2.2M

### Front Mounted Shredder Mowers

### Operator Manual

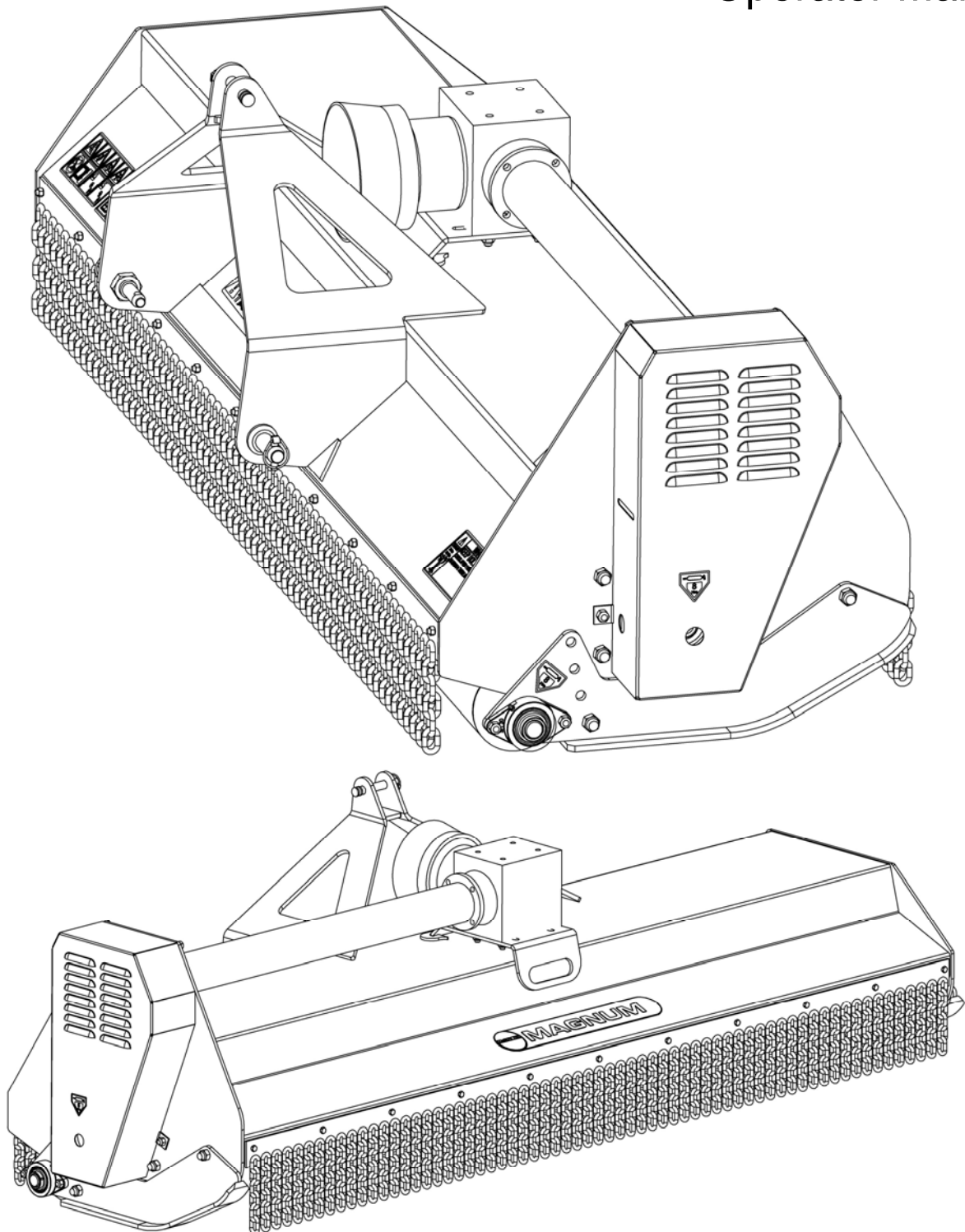

# IMPORTANT

## VERIFICATION OF WARRANTY REGISTRATION



### DEALER WARRANTY INFORMATION & REGISTRATION VERIFICATION

It is imperative that the selling dealer registers this machine with McConnel Limited before delivery to the end user – failure to do so may affect the validity of the machine warranty.

To register machines go to the McConnel Limited web site at [www.mcconnel.com](http://www.mcconnel.com), log onto 'Dealer Inside' and select the 'Machine Registration button' which can be found in the Service Section of the site. Confirm to the customer that the machine has been registered in the section below.

Should you experience any problems registering a machine in this manner please contact the McConnel Service Department on 01584 875848.

### Registration Verification

Dealer Name: .....
Dealer Address: .....
Customer Name: .....
Date of Warranty Registration: ...../...../..... Dealer Signature: .....

### NOTE TO CUSTOMER / OWNER

*Please ensure that the above section above has been completed and signed by the selling dealer to verify that your machine has been registered with McConnel Limited.*

**IMPORTANT:** During the initial 'bedding in' period of a new machine it is the customer's responsibility to regularly inspect all nuts, bolts and hose connections for tightness and re-tighten if required. New hydraulic connections occasionally weep small amounts of oil as the seals and joints settle in – where this occurs it can be cured by re-tightening the connection – *refer to torque settings chart below*. The tasks stated above should be performed on an hourly basis during the first day of work and at least daily thereafter as part of the machines general maintenance procedure.

**CAUTION: DO NOT OVER TORQUE HYDRAULIC FITTINGS AND HOSES**

### TORQUE SETTINGS FOR HYDRAULIC FITTINGS

HYDRAULIC HOSE ENDS		
BSP	Setting	Metric
1/4"	18 Nm	19 mm
3/8"	31 Nm	22 mm
1/2"	49 Nm	27 mm
5/8"	60 Nm	30 mm
3/4"	80 Nm	32 mm
1"	125 Nm	41 mm
1.1/4"	190 Nm	50 mm
1.1/2"	250 Nm	55 mm
2"	420 Nm	70 mm

PORT ADAPTORS WITH BONDED SEALS		
BSP	Setting	Metric
1/4"	34 Nm	19 mm
3/8"	47 Nm	22 mm
1/2"	102 Nm	27 mm
5/8"	122 Nm	30 mm
3/4"	149 Nm	32 mm
1"	203 Nm	41 mm
1.1/4"	305 Nm	50 mm
1.1/2"	305 Nm	55 mm
2"	400 Nm	70 mm



# WARRANTY POLICY

## WARRANTY REGISTRATION

All machines must be registered, by the selling dealer with McConnel Ltd, before delivery to the end user. On receipt of the goods it is the buyer's responsibility to check that the Verification of Warranty Registration in the Operator's Manual has been completed by the selling dealer.

### 1. LIMITED WARRANTIES

- 1.01. *All mounted machines supplied by McConnel Ltd are warranted to be free from defects in material and workmanship from the date of sale to the original purchaser for a period of 12 months, unless a different period is specified.  
All Self Propelled Machines supplied by McConnel Ltd are warranted to be free from defects in material and workmanship from the date of sale to the original purchaser for a period of 12 months or 1500 hours. Engine warranty will be specific to the Manufacturer of that unit.*
- 1.02. *All spare parts supplied by McConnel Ltd and purchased by the end user are warranted to be free from defects in material and workmanship from the date of sale to the original purchaser for a period of 6 months. All parts warranty claims must be supported by a copy of the failed part invoice to the end user. We cannot consider claims for which sales invoices are not available.*
- 1.03. *The warranty offered by McConnel Ltd is limited to the making good by repair or replacement for the purchaser any part or parts found, upon examination at its factory, to be defective under normal use and service due to defects in material or workmanship. Returned parts must be complete and unexamined. Pack the component(s) carefully so that any transit damage is avoided. All ports on hydraulic items should be drained of oil and securely plugged to prevent seepage and foreign body ingress. Certain other components, electrical items for example, may require particular care when packing to avoid damage in transit.*
- 1.04. *This warranty does not extend to any product from which McConnel Ltd's serial number plate has been removed or altered.*
- 1.05. *The warranty policy is valid for machines registered in line with the terms and conditions detailed and on the basis that the machines do not extend a period of 24 months or greater since their original purchase date, that is the original invoice date from McConnel Limited.  
Machines that are held in stock for more than 24 months cannot be registered for warranty.*
- 1.06. *This warranty does not apply to any part of the goods, which has been subjected to improper or abnormal use, negligence, alteration, modification, fitment of non-genuine parts, accident damage, or damage resulting from contact with overhead power lines, damage caused by foreign objects (e.g. stones, iron, material other than vegetation), failure due to lack of maintenance, use of incorrect oil or lubricants, contamination of the oil, or which has served its normal life. This warranty does not apply to any expendable items such as blades, belts, clutch linings, filter elements, flails, flap kits, skids, soil engaging parts, shields, guards, wear pads, pneumatic tyres or tracks.*
- 1.07. *Temporary repairs and consequential loss - i.e. oil, downtime and associated parts are specifically excluded from the warranty.*
- 1.08. *Warranty on hoses is limited to 12 months and does not include hoses which have suffered external damage. Only complete hoses may be returned under warranty, any which have been cut or repaired will be rejected.*
- 1.09. *Machines must be repaired immediately a problem arises. Continued use of the machine after a problem has occurred can result in further component failures, for which McConnel Ltd cannot be held liable, and may have safety implications.*
- 1.10. *If in exceptional circumstances a non McConnel Ltd part is used to effect a repair, warranty reimbursement will be at no more than McConnel Ltd's standard dealer cost for the genuine part.*

- 1.11. *Except as provided herein, no employee, agent, dealer or other person is authorised to give any warranties of any nature on behalf of McConnell Ltd.*
- 1.12. *For machine warranty periods in excess of 12 months the following additional exclusions shall apply:*
  - 1.12.1. *Hoses, exposed pipes and hydraulic tank breathers.*
  - 1.12.2. *Filters.*
  - 1.12.3. *Rubber mountings.*
  - 1.12.4. *External electric wiring.*
  - 1.12.5. *Bearings and seals*
  - 1.12.6. *External Cables, Linkages*
  - 1.12.7. *Loose/Corroded Connections, Light Units, LED's*
  - 1.12.8. *Comfort items such as Operator Seat, Ventilation, Audio Equipment*
- 1.13. *All service work, particularly filter changes, must be carried out in accordance with the manufacturer's service schedule. Failure to comply will invalidate the warranty. In the event of a claim, proof of the service work being carried out may be required.*
- 1.14. *Repeat or additional repairs resulting from incorrect diagnosis or poor quality previous repair work are excluded from warranty.*

***NB Warranty cover will be invalid if any non-genuine parts have been fitted or used. Use of non-genuine parts may seriously affect the machine's performance and safety. McConnell Ltd cannot be held responsible for any failures or safety implications that arise due to the use of non-genuine parts.***

## **2. REMEDIES AND PROCEDURES**

- 2.01. *The warranty is not effective unless the Selling Dealer registers the machine, via the McConnell web site and confirms the registration to the purchaser by completing the confirmation form in the operator's manual.*
- 2.02. *Any fault must be reported to an authorised McConnell Ltd dealer as soon as it occurs. Continued use of a machine, after a fault has occurred, can result in further component failure for which McConnell Ltd cannot be held liable.*
- 2.03. *Repairs should be undertaken within two days of the failure. Claims submitted for repairs undertaken more than 2 weeks after a failure has occurred, or 2 days after the parts were supplied will be rejected, unless the delay has been authorised by McConnell Ltd. Please note that failure by the customer to release the machine for repair will not be accepted as a reason for delay in repair or submitting warranty claims.*
- 2.04. *All claims must be submitted, by an authorised McConnell Ltd Service Dealer, within 30 days of the date of repair.*
- 2.05. *Following examination of the claim and parts, McConnell Ltd will pay, at their discretion, for any valid claim the invoiced cost of any parts supplied by McConnell Ltd and appropriate labour and mileage allowances if applicable.*
- 2.06. *The submission of a claim is not a guarantee of payment.*
- 2.07. *Any decision reached by McConnell Ltd. is final.*

## **3. LIMITATION OF LIABILITY**

- 3.01. *McConnell Ltd disclaims any express (except as set forth herein) and implied warranties with respect to the goods including, but not limited to, merchantability and fitness for a particular purpose.*
- 3.02. *McConnell Ltd makes no warranty as to the design, capability, capacity or suitability for use of the goods.*
- 3.03. *Except as provided herein, McConnell Ltd shall have no liability or responsibility to the purchaser or any other person or entity with respect to any liability, loss, or damage caused or alleged to be caused directly or indirectly by the goods including, but not limited to, any indirect, special, consequential, or incidental damages resulting from the use or operation of the goods or any breach of this warranty. Notwithstanding the above limitations and warranties, the manufacturer's liability hereunder for damages incurred by the purchaser or others shall not exceed the price of the goods.*
- 3.04. *No action arising out of any claimed breach of this warranty or transactions under this warranty may be brought more than one (1) year after the cause of the action has occurred.*

#### **4. MISCELLANEOUS**

- 4.01. McConnel Ltd may waive compliance with any of the terms of this limited warranty, but no waiver of any terms shall be deemed to be a waiver of any other term.*
- 4.02. If any provision of this limited warranty shall violate any applicable law and is held to be unenforceable, then the invalidity of such provision shall not invalidate any other provisions herein.*
- 4.03. Applicable law may provide rights and benefits to the purchaser in addition to those provided herein.*

---

*McConnel Limited*



# DECLARATION OF CONFORMITY

*Conforming to EU Machinery Directive 2006/42/EC*

We,

**McCONNEL LIMITED**, Temeside Works, Ludlow, Shropshire SY8 1JL, UK

*Hereby declare that:*

The Product; *Tractor Mounted Flail Mower*

Product Code; *FHR3*

Serial No. & Date ..... Type .....

Manufactured in; *United Kingdom*

Complies with the required provisions of the Machinery Directive 2006/42/EC  
The machinery directive is supported by the following harmonized standards;

- BS EN ISO 12100 (2010) Safety of machinery – General principles for design – Risk assessment and risk reduction.
- BS EN 349 (1993) + A1 (2008) Safety of machinery - Minimum distances to avoid the entrapment with human body parts.
- BS EN ISO 14120 (2015) Safety of machinery - Guards general requirements for the design and construction of fixed and movable guards.
- BS EN 4413 (2010) Hydraulic fluid power. Safety requirements for systems and their components.

McCONNEL LIMITED operates an ISO 9001:2008 quality management system, certificate number: FM25970.

This system is continually assessed by the;

British Standards Institution (BSI), Beech House, Milton Keynes, MK14 6ES, UK

BSI is accredited by UK Accreditation Service, accreditation number: UKAS 003.

The EC declaration only applies if the machine stated above is used in accordance with the operating instructions.

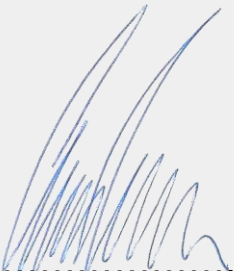
Signed  ..... *Responsible Person*  
*CHRISTIAN DAVIES on behalf of McCONNEL LIMITED*

Status: *General Manager*

Date: *January 2018*

## **FLAIL MOWER INSPECTION AND MAINTENANCE**

---

A daily equipment inspection of the tractor and mower should be conducted before the equipment is used. You may use the inspection sheets to assist with these daily inspections. Any damaged or missing guards should be repaired or replaced before operating the mower. Failure to repair the damaged shield can result in objects being thrown from the mower and possibly hitting the operator or bystander.

### **Inspect the Mower for Safe Operating Condition**

- Make sure the driveline guards and shielding are in place and in good repair.
- Inspect the chain guards, flexible and/or solid deflector thrown object shielding to assure that they are in place on the front and rear of the mower deck and in good repair. Repair or replace any damaged or missing thrown object shields.
- Ensure the mower cutting height is set high enough to reduce the possibility of the mower blades contacting the ground. Actual height will be dependent on the ground conditions. Increase the height when working in rough or undulating conditions.
- Inspect for broken, chipped, bent, missing, or severely worn blades. Replace damaged blades before operating the mower. Ensure the blade retaining bolts and fasteners are secure and tight.
- Lubricate the driveline universal joints and telescoping members daily.
- Inspect the wheel lug bolt/nuts to assure that they are tight.
- If mower is equipped with pneumatic tires, make sure they have the required air pressure.
- Inspect for worn or damaged decals and safety instructions. Replace unreadable, damaged or missing safety decals.
- Follow the operator's manual(s) inspection and maintenance instructions for lubricating parts, and keeping thrown object shielding, driveline guards, rotating parts shields, mower blades and decals in good repair.

### **Inspect the Tractor for Safe Operating Condition:**

- Inspect the controls, lights, SMVs (Slow Moving Vehicle sign), seat belts, and ROPS to assure that they are in place and in good working order.
- Be sure the tires, wheels, lug bolts/nuts are in good condition.
- Make sure the tractor brakes and steering are in proper operating condition.
- Follow the operator's manual(s) inspection and maintenance procedures for keeping the tractor in good and safe condition before operating.

The inspection sheet on the following page should be kept in this book as a record. A second sheet is included for you to cut out and photocopy or the inspection sheets can be downloaded from our website at;

<http://www.mcconnel.com/support/aftersales/default.aspx?nav=After Sales>







# FLAIL MOWERS PRE-OPERATION Inspection

Mower ID \_\_\_\_\_ Date: \_\_\_\_\_ Shift: \_\_\_\_\_

## WARNING



Before conducting the inspection, make sure the tractor engine is off, with the key removed, all rotation has stopped and the tractor is in park with the parking brake engaged. Make sure the mower is resting on the ground or is securely blocked up and supported and all hydraulic pressure has been relieved.

Item	Condition at start of shift	Specific Comments if not O.K.
The Operator's Manual is in the Canister on the mower		
All Warning Decals are in place, clean and legible		
The Hyd. Cylinder pins are tight and correctly secured		
The Hyd Cylinder hose connections are tight		
There are no oil leaks		
There are no damaged hoses		
Flails are not missing chipped, broken or excessively worn		
The Flail bolts are tight		
The Front & Rear Flaps are fitted and in good condition		
The Skid shoes are in good condition & tight		
The Rotor Bearings are in good condition and greased		
The Roller bearings are in good condition and greased		
There are no cracks or holes in flail casing		
The drive line/gearbox shaft guard is in good condition		
The drive line/gearbox shaft guard is correctly secured		
Driveline telescoping members & u-joints are lubricated		
Driveline yokes are securely attached to tractor & mower		
All linkage mounting pins are securely fastened		

Operators Signature: \_\_\_\_\_

**DO NOT OPERATE an UNSAFE TRACTOR or MOWER**



# TRACTOR PRE-OPERATION Inspection

Power Arm ID \_\_\_\_\_ Date: \_\_\_\_\_ Shift: \_\_\_\_\_

## WARNING



Before conducting the inspection, make sure the tractor engine is off, the key is removed all rotation has stopped and the tractor is in park with the parking brake engaged. Any implement attached to the tractor is firmly on the ground.

Item	Condition at start of shift	Specific Comments if not O.K.
The flashing lights function properly.		
All lights are clean and working correctly		
All cab windows are clean and wipers working correctly		
The SMV sign, where required, is clean and visible.		
The tyres are in good condition with correct pressure.		
The wheel nuts are tight.		
The tractor brakes are in good condition.		
The steering linkage is in good condition.		
There are no visible oil leaks.		
The hydraulic controls function properly.		
The ROPS or ROPS cab is in good condition.		
The seatbelt is in place and in good condition.		
The 3-point hitch is in good condition.		
The drawbar/pick up hook is secure & in good condition		
The PTO master shield is in place.		
The engine oil level is full.		
The brake fluid level is full.		
The power steering fluid level is full.		
The fuel level is adequate.		
The engine coolant fluid level is full.		
The radiator & oil cooler are free of debris.		
The air filter is in good condition		

Operators Signature: \_\_\_\_\_

**DO NOT OPERATE an UNSAFE TRACTOR or MOWER**



# FLAIL MOWERS PRE-OPERATION Inspection

Mower ID \_\_\_\_\_ Date: \_\_\_\_\_ Shift: \_\_\_\_\_

## WARNING



Before conducting the inspection, make sure the tractor engine is off, with the key removed, all rotation has stopped and the tractor is in park with the parking brake engaged. Make sure the mower is resting on the ground or is securely blocked up and supported and all hydraulic pressure has been relieved.

Item	Condition at start of shift	Specific Comments if not O.K.
The Operator's Manual is in the Canister on the mower		
All Warning Decals are in place, clean and legible		
The Hyd. Cylinder pins are tight and correctly secured		
The Hyd Cylinder hose connections are tight		
There are no oil leaks		
There are no damaged hoses		
Flails are not missing chipped, broken or excessively worn		
The Flail bolts are tight		
The Front & Rear Flaps are fitted and in good condition		
The Skid shoes are in good condition & tight		
The Rotor Bearings are in good condition and greased		
The Roller bearings are in good condition and greased		
There are no cracks or holes in flail casing		
The drive line/gearbox shaft guard is in good condition		
The drive line/gearbox shaft guard is correctly secured		
Driveline telescoping members & u-joints are lubricated		
Driveline yokes are securely attached to tractor & mower		
All linkage mounting pins are securely fastened		

Operators Signature: \_\_\_\_\_

**DO NOT OPERATE an UNSAFE TRACTOR or MOWER**



# TRACTOR PRE-OPERATION Inspection

Power Arm ID \_\_\_\_\_ Date: \_\_\_\_\_ Shift: \_\_\_\_\_

## WARNING



Before conducting the inspection, make sure the tractor engine is off, the key is removed all rotation has stopped and the tractor is in park with the parking brake engaged. Any implement attached to the tractor is firmly on the ground.

Item	Condition at start of shift	Specific Comments if not O.K.
The flashing lights function properly.		
All lights are clean and working correctly		
All cab windows are clean and wipers working correctly		
The SMV sign, where required, is clean and visible.		
The tyres are in good condition with correct pressure.		
The wheel nuts are tight.		
The tractor brakes are in good condition.		
The steering linkage is in good condition.		
There are no visible oil leaks.		
The hydraulic controls function properly.		
The ROPS or ROPS cab is in good condition.		
The seatbelt is in place and in good condition.		
The 3-point hitch is in good condition.		
The drawbar/pick up hook is secure & in good condition		
The PTO master shield is in place.		
The engine oil level is full.		
The brake fluid level is full.		
The power steering fluid level is full.		
The fuel level is adequate.		
The engine coolant fluid level is full.		
The radiator & oil cooler are free of debris.		
The air filter is in good condition		

Operators Signature: \_\_\_\_\_

**DO NOT OPERATE an UNSAFE TRACTOR or MOWER**

## LIST OF CONTENTS

---

General Information	1
Machine Description & Purpose of Use	2
Machine Identification	2
Technical Data	2
Technical Specifications	3
Safety Information	4
Safety Decals	5
Vehicle / Tractor Preparation	6
Machine Attachment	7
PTO Shaft	8
Pre-Operational Checks	8
Setting Up and Adjustment	9
Drive Belts	10
Belt Adjustment	11
Operation	13
Detachment and Storage	14
Maintenance	15
Troubleshooting	17
Torque Settings	18

## GENERAL INFORMATION

---

Always read this manual before fitting or operating the machine – whenever any doubt exists contact your dealer or the McConnel Service Department for advice and assistance.

### Use only McConnel Genuine Service Parts on McConnel Equipment and Machines

DEFINITIONS – The following definitions apply throughout this manual:

#### WARNING

An operating procedure, technique etc., which –  
can result in personal injury or loss of life if not observed carefully.

#### CAUTION

An operating procedure, technique etc., which –  
can result in damage to either machine or equipment if not observed carefully.

#### NOTE

An operating procedure, technique etc., which –  
is considered essential to emphasis.

#### LEFT AND RIGHT HAND

This term is applicable to the machine when attached to the tractor and is viewed  
from the rear – this also applies to tractor references.

## MACHINE & DEALER INFORMATION

*Record the Serial Number of your machine on this page and always quote this number when ordering parts. Whenever information concerning the machine is requested remember also to state the make and model of tractor to which the machine is fitted.*

Machine Serial Number:	Installation Date:
Machine Model details:	
Dealer Name:	
Dealer Address:	
Dealer Telephone No:	
Dealer Email Address:	

## MACHINE DESCRIPTION & PURPOSE OF USE

---

Magnum 1.6, 1.9 & 2.2 machines are tractor front-mounted universal flail mower/shredders designed primarily for the mulching of grasses, brambles, small bushes, branches, vines, and general crop residues. Their tough construction and working widths of 1.6m, 1.9m or 2.2m make them the ideal high performance maintenance machine for use in green areas, vineyards, orchards, on verges and in scrubland by farmers and contractors alike.

*This machine should only be used to perform the tasks for which it was designed – use of the machine for any other function is both dangerous to persons and damaging to components.*

## MACHINE IDENTIFICATION

---

Each machine is fitted with an identification plate with the following information:

1. Machine (Part Number)
2. Machine Serial No.
3. Machine Weight

When ordering spares or replacement parts from your local dealer it is important to quote both Part Number and Serial Number as stated on the identification plate so the machine and model can be quickly and correctly identified.



**Machine Identification Plate**

## TECHNICAL DATA

---

### Component Identification

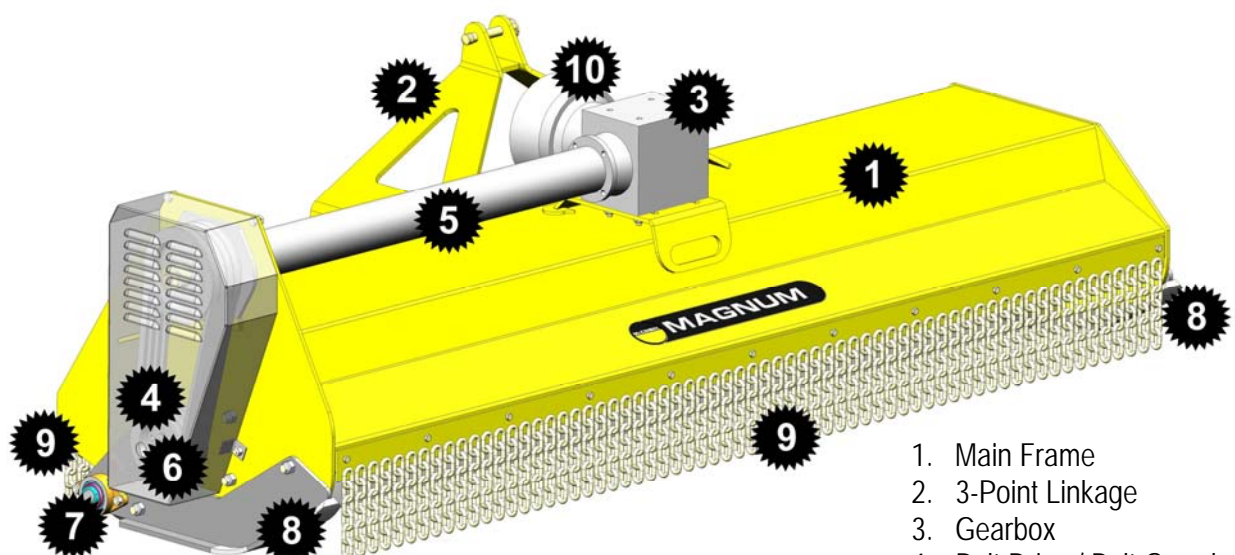

1. Main Frame
2. 3-Point Linkage
3. Gearbox
4. Belt Drive / Belt Guard
5. Drive Shaft
6. Rotor
7. Rear Roller
8. Skids
9. Chain Guarding
10. PTO Guarding



## TECHNICAL SPECIFICATIONS

SPECIFICATION	MAGNUM 1.6	MAGNUM 1.9	MAGNUM 2.2
Working Width	1600mm	1900mm	2200mm
Tractor Power Requirement	35-40 HP	45-50 HP	55-60 HP
PTO RPM	540RPM	540RPM	540RPM
Rotor Shaft RPM	2300RPM	2300RPM	2300RPM
Hammer Blades ( <i>2.2 Model only</i> )	-	-	64
Y-Blades (*)	64	72	80
Paddle Flails (*)	32	36	40
Belts (Qty.)	3	4	4
Machine Weight	-	-	780kg
Linkage Type	3-Point (Cat.I & II)	3-Point (Cat.I & II)	3-Point (Cat.I & II)
Machine Width	1930mm	2210mm	2510mm
Machine Length	900mm	900mm	900mm
Machine Height	750mm	750mm	750mm

(\*) *Requires an alternative rotor to be fitted*

### Optional Equipment

Machines are supplied as standard fitted with hammer blade flails; Y-blade and paddle flails are available as an option but where these are specified the machine must be fitted with a different rotor.

The cutting capability of the each particular type of flail will be dependant on the sort and hardness of the material being cut, but in general the following cutting thicknesses apply;

**Paddle flails** – *for materials up to a maximum of 15mm diameter.*

**Y-blade flails** – *for materials up to a maximum of 30mm diameter.*

**Hammer flails** – *for materials up to a maximum of 50mm diameter.*

### Noise Level

The sound level of this machine, as measured at the operator's ear, is within the range of 70 to 90 dB when the rear window of the tractor is open. We recommend that ear protectors are worn and the tractor windows kept closed at all times when operating this machine.

## SAFETY INFORMATION

---

### General safety rules:

- ▲ Always read and follow the instructions for the use and maintenance of the machine before carrying out any work operations or servicing tasks.
- ▲ Improper use of the machine is both highly dangerous to persons and damaging to the machine components – only use the machine for its designated task.
- ▲ Both operators and the maintenance fitters should be familiar with the machine and fully aware of dangers surrounding improper use or incorrect repairs.
- ▲ Before starting, checks to both tractor and machine must be carried out as regards: functionality, road safety, accident prevention rules.
- ▲ Even when using the machine correctly, stones or other objects may be thrown a long distance. Therefore nobody must stand within the danger area. Special attention must be paid when working near roads or buildings.
- ▲ Use tractor's fitted with safety cabs.
- ▲ The condition of flails and of machine guards must be checked before beginning the daily work - they must be replaced if damaged or missing before you use the machine.
- ▲ During checks or repairs, make sure nobody could start the machine by mistake.
- ▲ Never wear loose or fluttering clothes.
- ▲ Never carry passengers on the tractor.
- ▲ Never carry passengers on the machine.
- ▲ Never connect the power takeoff with the engine running.
- ▲ Never approach the machine until the rotor has completely stopped.
- ▲ Do not enter the working zone of the PTO shaft. It is dangerous to approach the rotating parts of a machine.
- ▲ Keep the PTO shaft guard in good condition.
- ▲ Before starting, check the surrounding area for the likely presence of children and/or animals.
- ▲ Do not stand near the machine when it is operating.
- ▲ The PTO shaft must be assembled and disassembled only with the engine stopped and the starting key removed.
- ▲ Before connecting the power takeoff, check that the speed and the rotational direction correspond to those of the machine.
- ▲ Immediately replace missing or damaged safety decals.
- ▲ Before leaving the tractor with the machine attached, proceed as follows:
  1. Disconnect the power takeoff,
  2. Put the machine steadily on the ground using the tractor's hydraulic lift.
  3. Apply the hand brake and, if the ground is steeply sloping, wedge the tractor.
  4. Remove the starting key.

## Transportation Safety

- ▲ In transport, reduce speed, especially on bumpy roads, the weight of the machine may render driving difficult and damage the machine itself.
- ▲ Ensure the levers that operate the hydraulic lift are locked, to avoid the lowering of the machine during transport.
- ▲ When driving on public roads, respect all road rules in force.
- ▲ Never transport the machine with the rotor running, even for short distances.

## Operating Safety

- ▲ Pay special attention when working with the machine not to touch fixed objects such as road drain, walls, shafts, kerbs, guard rails, tracks etc. This could cause the breakage of the flails, which would be thrown out of the machine at very high speed.
- ▲ If wires, ropes or chains should become entangled in the rotor stop immediately to prevent damage or dangerous situations; stop the rotor and the tractor, take out the starting key. Put working gloves on; clear the rotor with the aid of pliers or shears. Do not try to disentangle by inverting the rotational direction of the rotor.
- ▲ Do not use the machine when excessive vibration is experienced, as this may cause breakage and serious damage - find the cause of the vibration and eliminate it before using the machine again.

---

Although the information given here covers a wide range of safety subjects, it is impossible to predict every eventuality that can occur under differing circumstances whilst operating this machine. No advice given here can replace 'good common sense' and 'total awareness' at all times, but will go a long way towards the safe use of your McConnell machine.

---

## SAFETY DECALS



1. Danger; do not work under a raised or unsupported machine.
2. Danger zone, keep clear; risk from crushing.
3. Keep clear of working machine; risk from projection of objects.
4. Keep a safe distance from the machine at all times; risk from raised machine.
5. Always switch machine off, remove starting key and read instruction manual before performing service or maintenance work on the machine.
6. Risk of hand or feet injuries; always ensure all machine safety guards are in place when the machine is running.
7. Keep a safe distance from the machine at all times; risk of entanglement.
8. Ensure nuts and bolts are kept tight.
9. Read the manual first before attempting to operate or service the machine.

## VEHICLE / TRACTOR PREPARATION

---

We recommend vehicles are fitted with cabs using 'safety glass' windows and protective guarding when used with our machines.

Fit Operator Guard (Part No. 7313324) using the hooks provided. Shape the mesh to cover all vulnerable areas.

Remember the driver must be looking through mesh and/or polycarbonate

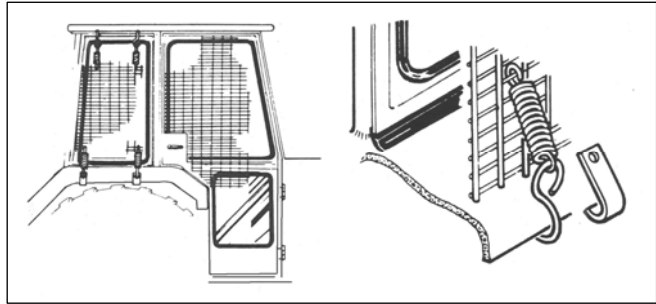

glazing when viewing the machine in all positions - unless the vehicle/ cab manufacturer can demonstrate that the penetration resistance is equivalent to, or higher than, that provided by mesh/polycarbonate glazing. If the tractor has a roll bar only, a frame must be made to carry both mesh and polycarbonate glazing. The operator should also use personal protective equipment to reduce the risk of serious injury such as; eye protection (mesh visor to EN1731 or safety glasses to EN166), hearing protection to EN352, safety helmet to EN297, gloves, filter mask and high visibility clothing.

### Vehicle Ballast

It is imperative when attaching 'third-party' equipment to a vehicle that the maximum possible stability of the machine and vehicle combination is achieved – this can be accomplished by the utilisation of 'ballast' in order to counter-balance the additional equipment added.

Front weights may be required for rear mounted machines to place 15% of total outfit weight on the front axle for stable transport on the road and to reduce 'crabbing' due to the drag of the cutting unit when working on the ground.

Where a machine works to the side of the tractor rear weights may be required to maintain a reasonable amount of rear axle load on the opposing wheel.

All factors must be addressed in order to match the type and nature of the equipment added to the circumstances under which it will be used - factors that effect stability are:

- *Centre of gravity of the tractor/machine combination.*
- *Geometric conditions, e.g. position of the cutting head and ballast.*
- *Weight, track width and wheelbase of the tractor.*
- *Acceleration, braking, turning and the relative position of the cutting unit during these operations.*
- *Ground conditions, e.g. slope, grip, load capability of the soil/surface.*
- *Rigidity of implement mounting.*

### Suggestions to increase stability:

- *Increasing rear wheel track - a vehicle with a wider wheel track is more stable.*
- *Ballasting the wheel; it is preferable to use external weights but liquid can be added to around 75% of the tyre volume – water with anti-freeze or the heavier Calcium Chloride alternative can be used.*
- *Addition of weights – care should be taken in selecting the location of the weights to ensure they are added to a position that offers the greatest advantage.*
- *Front axle locking, check with tractor manufacturer.*

---

The advice above is offered as a guide for stability only and is not a guide to vehicle strength. It is therefore recommended that you consult your vehicle manufacturer or local dealer to obtain specific advice on this subject, additionally advice should be sought from a tyre specialist with regard to tyre pressures and ratings suitable for the type and nature of the machine you intend to fit.

---

## ATTACHING THE MACHINE TO THE TRACTOR

---

Attachment of machine to tractor should always be performed on a firm level site.

### Linkage Positions

A – Lower Attachment Points (*Linkage Arms*)

B – Upper Attachment Point (*Top Link*)

*Note; lower linkage pins are compatible with both Cat. I and Cat. II linkage systems.*

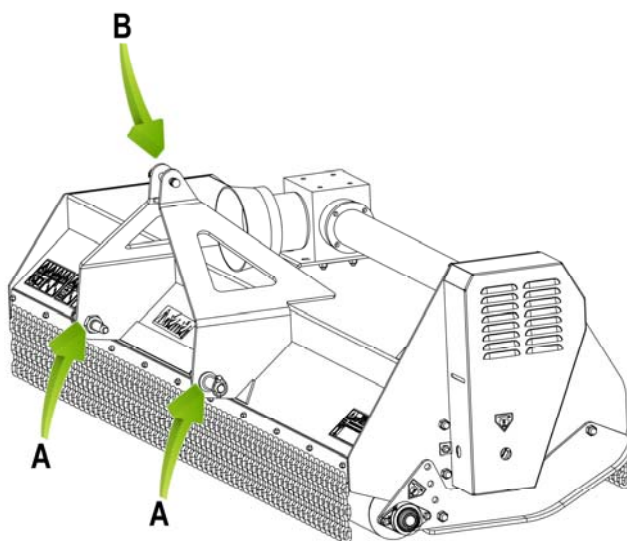

### Attachment to Tractor

Position the tractor's lower linkage at the same height as the machine's lower attachment points, indicated 'A' in the diagram above.

Carefully drive the tractor squarely up to the machine and attach the tractor's lower linkage points to the machine's linkage pins 'A'; for Cat. I linkage systems attachment will be on the pins on the inside of the linkage frame or for Cat. II linkage systems on the pins to the outer sides of the linkage frame. Ensure security pins are fitted to the connected end of each linkage pin.

Fit top link to upper attachment point 'B'.

Raise the machine on the tractor's hydraulics and adjust the top link so that the machine is parallel to the ground.

Fit and adjust check chains and/or stabiliser bars to lock the machine into a central position on the tractor.

Fit PTO Shaft and attach torque chains to a suitable location – refer to following page for details of PTO measurement and shaft length adjustment.

## PTO Shaft Measurement

Measure the PTO shaft and cut to the dimension shown – the finished length of the PTO shaft should be 75mm (3") less than the measured distance 'A' - between tractor shaft and gearbox stub shaft - to enable fitting.

### NOTE:

*For subsequent use with different tractors measure again, there must be a minimum shaft overlap of 150mm (6").*

Fit PTO in position and attach the torque chains to a convenient location to prevent the shaft guards from rotating.

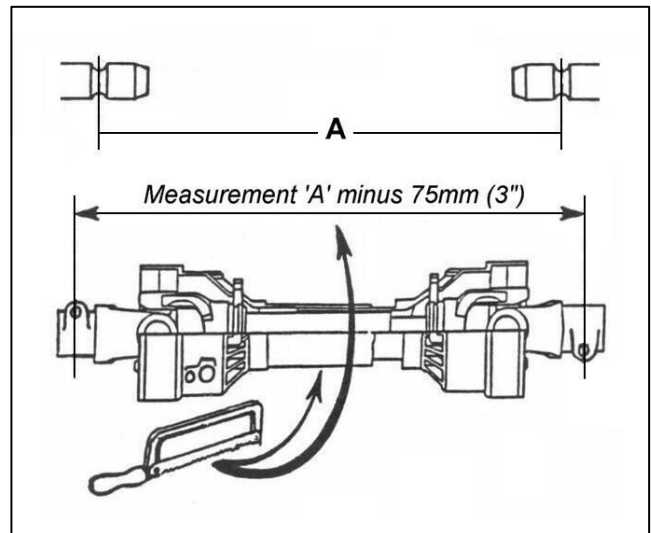

## PTO Shaft Length Adjustment

1. Shorten outer plastic tube to 40mm less than the shortest envisaged shaft length.
2. Remove the marked tube.
3. Remove same length from inner plastic tube and metal shaft profiles (inner and outer).
4. De-burr all edges and remove 'swarf' to ensure smooth operation.

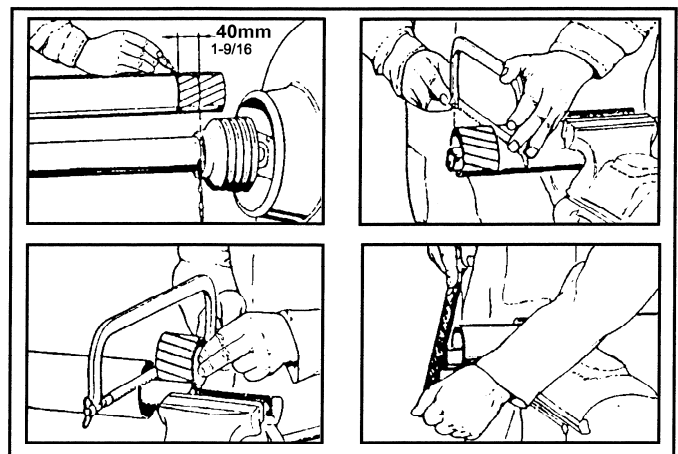

## Pre-Operational Checks

Before commencing work with the machine the following checks should be performed;

- Make a visual inspection of the machine to ensure it is in good operational condition.
- Check all safety guarding is in position and in full working order.
- Check rotor for missing or damaged flails and replace if required.
- Check all greasing points are well lubricated.
- Check gearbox oil level.
- Check belt tension and adjust if required.
- Check PTO speed and direction match that of the machine.

## SETTING UP AND ADJUSTMENT

### Cutting Height

The height of cut is regulated by the mounting position of the rear roller and skids assembly. The rear of the skids which support the roller can be pivoted into a choice of 4 working positions thus providing 4 different cutting heights. The height of cut selected primarily depends on the finish required but may also be influenced by the specific working conditions and volume of material.

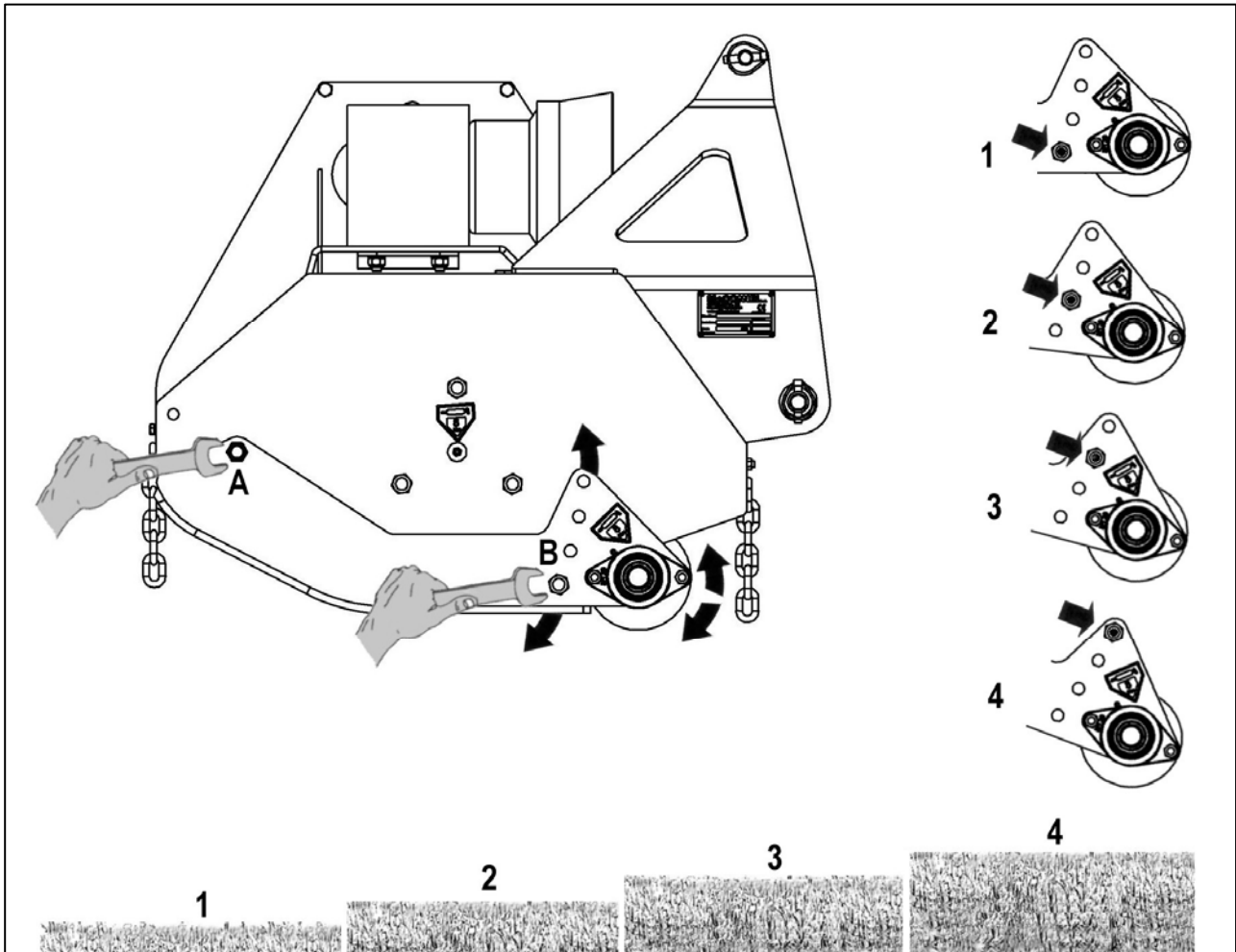

### Adjusting the Cutting Height



**WARNING!** Disengage PTO, switch off engine and remove starting key before adjusting the roller height. Ensure both machine and roller/skid assembly are safely and independently supported at all times during the adjustment procedure.

The procedure for adjusting the cutting height is as follows (*refer to illustration above*);

With the unit parked on a firm level site, place the machine into a raised position with the roller clear of the ground.

Loosen nut and bolt 'A' at the front of the skids on both sides of the machine - *do not remove*.

With the roller safely supported, loosen and remove nut and bolt 'B' on both sides of the machine; *care must be adopted as the roller is now free to drop if it is not supported*.

Raise or lower the roller to the required height position and refit nut and bolt 'B' on both sides; *ensure matching holes are selected on each side of the machine*.

With nuts and bolts 'B' refitted all nuts and bolts can now be retightened fully.

## DRIVE BELTS

---

Power from the tractor via the machines gearbox and half-shaft is transferred to the rotor via a 4-belt pulley system.

### Belt Tension

It is important that the belts are kept correctly tensioned for both optimal operation of the machine and long lasting belt life. Belts are correctly tensioned when they deflect by 15mm under a load of 10kg (22lbs.). See following page for belt tensioning procedure.

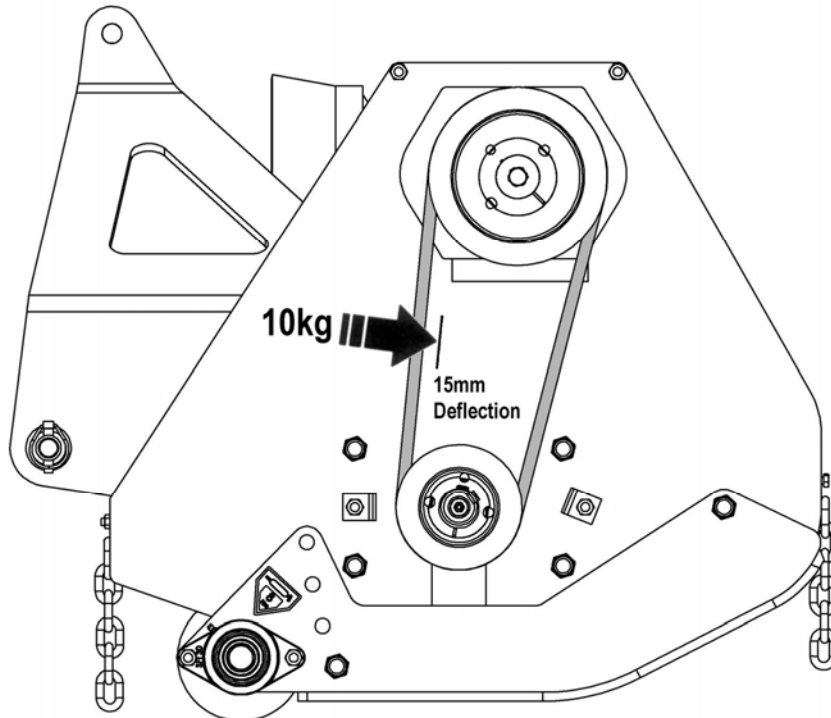

In addition to the belt tension the tightness of the taper lock bolts should be checked on a regular basis; the correct torque setting is 45Nm (33ft.lbs).

No other adjustment or maintenance will be required on the belt tensioning system other than routine inspection and general cleaning of components when checking the belts for wear.

### Belt Replacement

When fitting new belts they should be replaced as a complete set to ensure uniform drive tension; always use Genuine McConnell replacement parts (*Belt Part No. 21233.01*).

When replacing belt sets they must be correctly tensioned as shown on the following page - *inspect the belts after the first 2 hours of work and re-tension if necessary.*



## Belt Adjustment

The procedure for adjusting belt tension is as follows;



**WARNING:** Checking of belts and drive components should only be carried out with tractors engine switched off, starting key removed and the PTO shaft disconnected. Never attempt to run the machine with the belt guard removed.

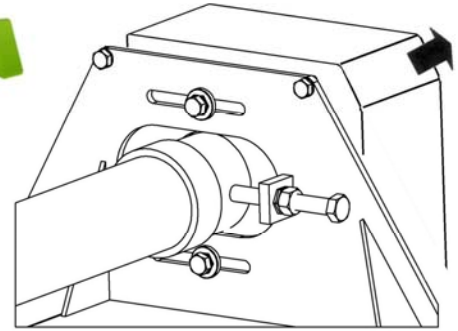
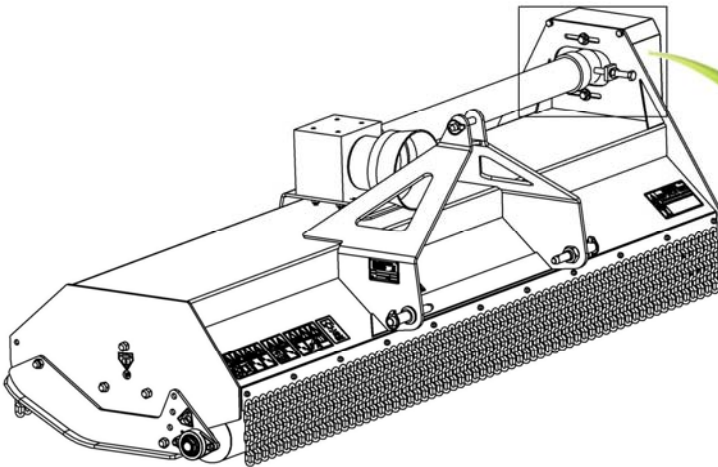

1. Remove belt cover.

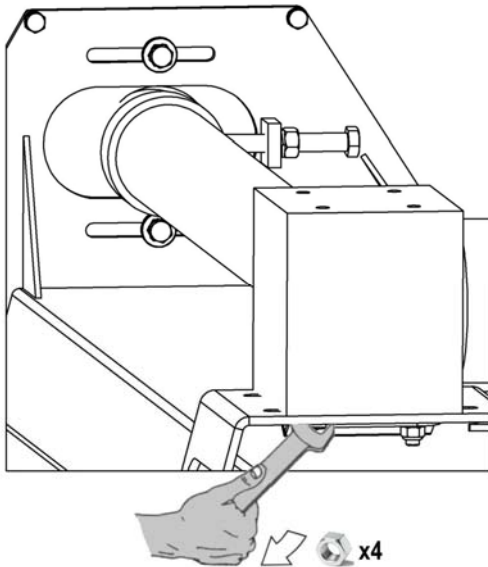

2. Slacken the 4 gearbox retaining nuts.

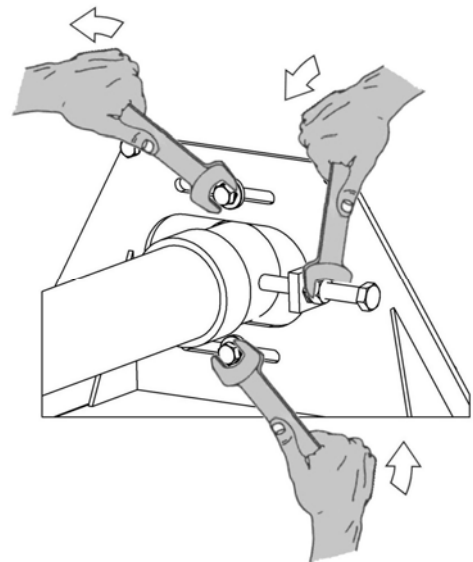

3. Slacken upper pulley fixing bolts and release adjuster locking nut.

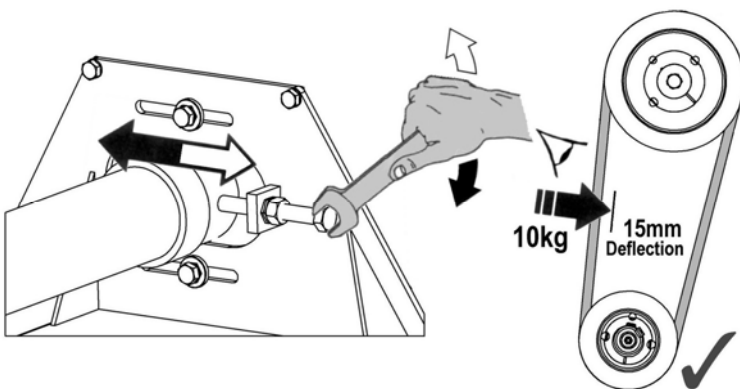

4. Turn adjuster to achieve the correct belt tension (15mm deflection under 10kg of load).

*Turning the adjuster clockwise will increase belt tension, anti-clockwise will decrease tension.*

*Half shaft must be kept parallel to the rotor during and after the tensioning procedure – see following page.*

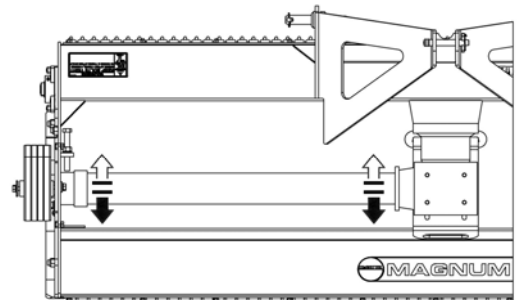

**IMPORTANT:** Ensure that the gearbox is moved by the same distance, and in the same direction, as the upper belt pulley; this will ensure that the half shaft remains parallel to the rotor allowing the belts to run true – failure to observe this may result in rapid belt wear, excess vibration and possible damage to components.

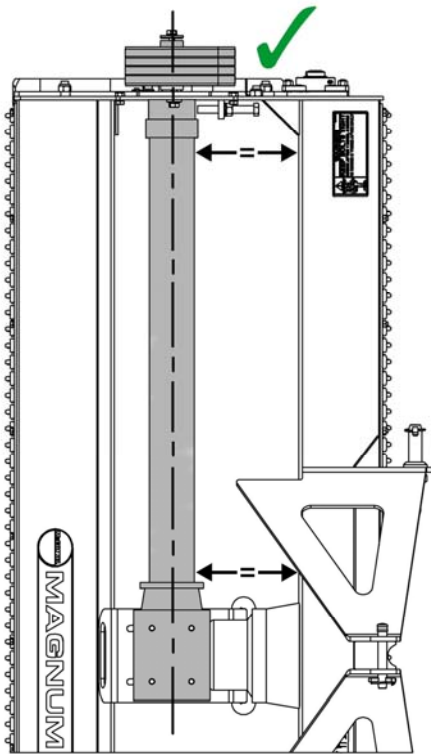

Correct Alignment

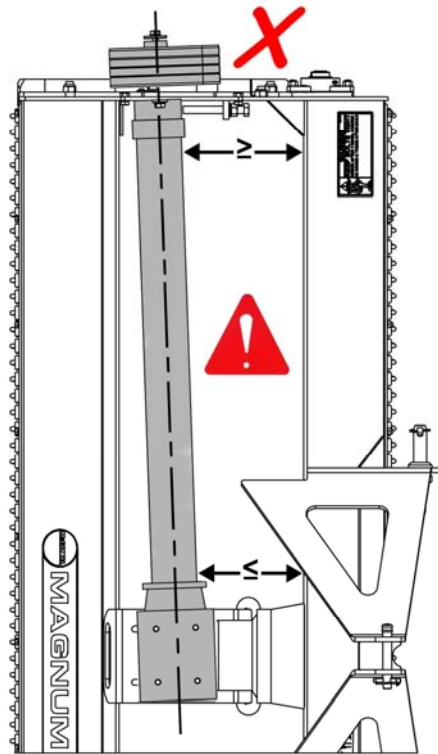

Incorrect Alignment

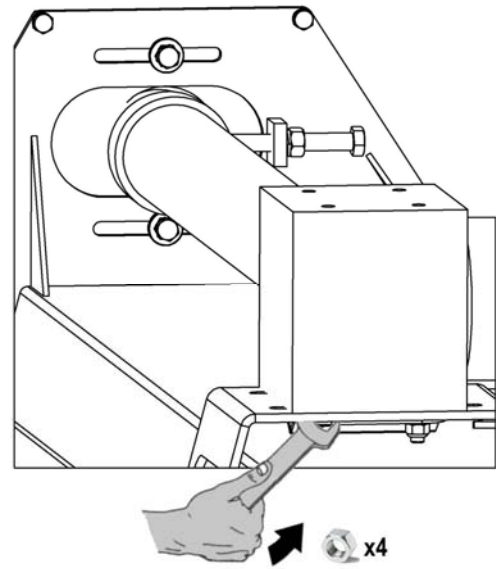
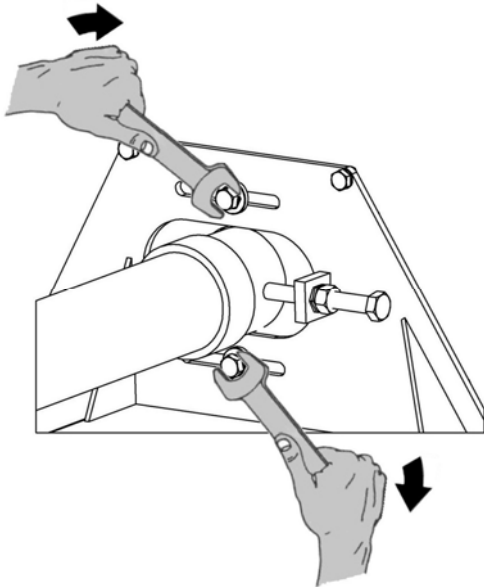

5. When belts are correctly tensioned, retighten the upper pulley fixing bolts and the 4 gearbox retaining nuts.

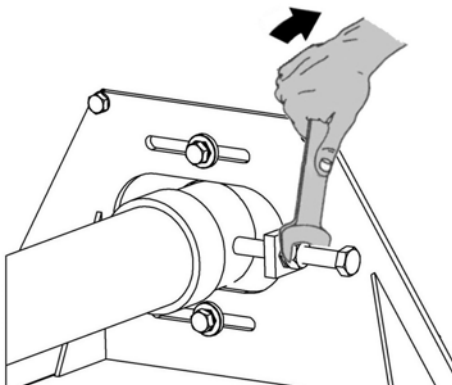

6. Re-tighten the adjuster lock nut.

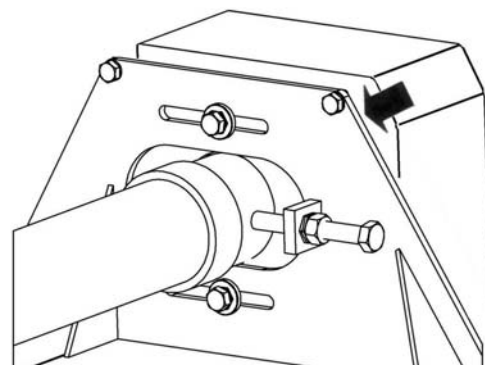

7. Re-fit belt guard.

## OPERATION

---

### Machine RPM

This machine is 540RPM - before operating the machine always ensure the RPM is compatible with the tractor PTO speed.

**WARNING:** Always check machine and tractor PTO speeds are compatible before using the machine.

### Operation

Ensure that the operator is suitably qualified to use a machine of this nature and that they have fully read and understood this manual - they should be aware of all safety aspects relating to the safe use of the machine. It is advisable that all 'first time' operators practice using the machine in a clear safe area prior to work in order to familiarise themselves with its operation.

After the initial first 2 hours of work with a new machine, nuts and bolts should be checked for tightness and the drive belts inspected and re-tensioned if required – *refer to belt section for details*.

Prior to starting work the area should be checked for dangerous objects such as large stones, wood, wire, glass etc. – hazardous objects should be removed from the area prior to operation with the machine. The location of unmovable or natural hazards should be noted, or if necessary 'marked', to indicate to the operator that the area should either be avoided or additional caution adopted whilst working around the hazard.

### Starting Work

With the machine switched off, lower it into a position approximately 10cm above the ground, start the machine and allow it to build up to the correct working speed before gently lowering the it onto the ground - the machine is now in its work position and forward travel can begin.

### Forward Speed

The forward working speed will depend on the working conditions and nature of the material being cut. Optimal speed will be in the region of 3-8 km/h (2-5 mph).



### Reversing & Turning

When reversing or turning the unit the machine must always be lifted clear of the ground to avoid damage.

### Transport

The following must be observed at all times when transporting the machine:

- Machine must be switched off.
- Machine must be raised to a suitable height for transportation.
- Speed must always be kept to a minimum, especially on bumpy roads or terrain.
- Always abide with local laws and road regulations.
- Be aware of the machines width.

## DETACHMENT & STORAGE

---

### **Detaching the machine from the tractor**

- Removal of the machine should be performed on a firm level site. The procedure for detachment is as follows:
- Gently lower the machine fully to the ground.
- Switch off the tractor and remove its starting key.
- Remove the PTO driveshaft.
- 'Chock' the rear roller to prevent risk of machine movement during the detachment procedure or whilst in storage.
- Remove the top link and detach lower attachment points.
- Carefully and slowly drive the tractor clear of the machine.
- Clean and lubricate the machine in preparation for next use.

### **Storage**

For extended periods of storage it is advisable that the machine be kept in a clean dry environment protected from the elements to avoid risk of corrosion. The machine should be thoroughly cleaned and lubricated prior to storage. At this point it is good practice to check the machine for worn or damaged components - any parts that require replacing should be ordered and fitted at the earliest opportunity so the machine is fully prepared for the next seasons work.

## MAINTENANCE

---

All maintenance, cleaning and repair operations must be performed with the machine firmly lowered to the ground and detached from the tractor or with the PTO disconnected, engine switched off and starting key removed. For any repairs or maintenance that requires access from underneath; the machine should be firmly and safely raised and propped using suitable purpose designed supports capable of bearing the machines full weight. Care should be adopted at all times when working with or under a raised machine.

### MAINTENANCE TASKS

The following preventative maintenance tasks should be performed at the timescales stated to both maximise efficiency and prolong the working life of the machine.

#### After first 2 hours of work - new machine or machine fitted with new belts.

- ✓ Check all nuts and bolt for tightness – *retighten if required.*
- ✓ Check belt tension and adjust if required – *refer to belt section for details of adjustment.*

#### After every 8 hours of work

- ✓ Check all nuts and bolt for tightness – *retighten if required.*
- ✓ Check belt tension and adjust if required – *refer to belt section for details of adjustment.*
- ✓ Check wear and condition of flails – *replacing missing, or damaged flails immediately.*
- ✓ Check condition of safety guards – *repair or replace if not performing their function.*
- ✓ Lubricate grease points – *see below for locations of grease points.*
- ✓ Check gearbox oil level – *top up if required.*
- ✓ Check rotor – *remove foreign objects that may be fouling or lodged in the rotor.*
- ✓ Check frame and 3-point hitch – *ensure all components are in a safe working condition.*

#### After every 100 hours

- ✓ Grease PTO driveshaft – *separate telescopic drive and apply grease to internal shaft.*

#### Every 12 months

- ✓ Change gearbox oil

### Grease Points

Lubricate the points shown using type LIS 3 grease.

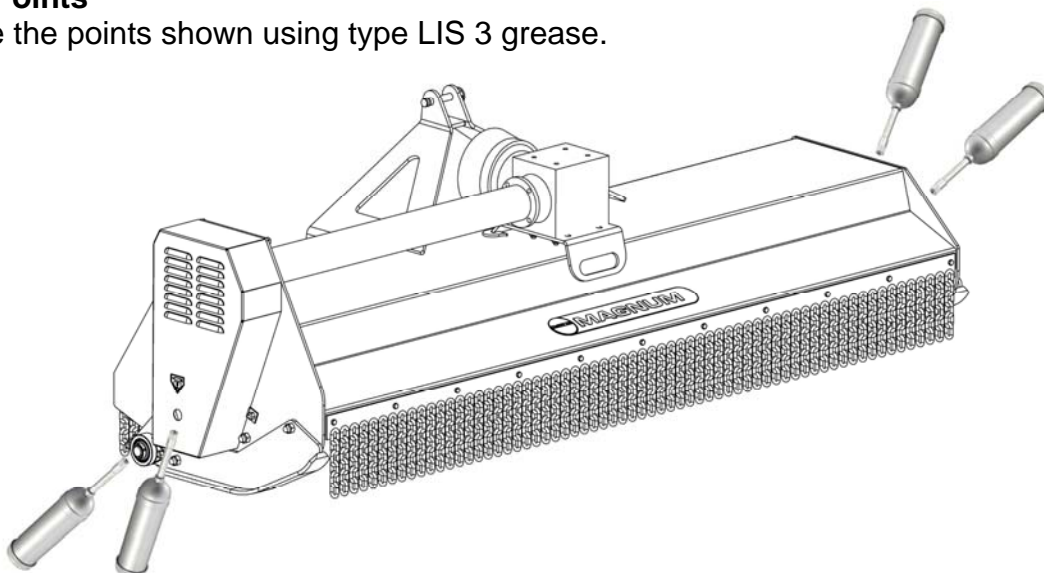

## Gearbox & Half Shaft Lubrication

Lubricant levels should be checked on a daily basis during work and topped up only if required.

Checking the level is by removal of the oil level plug; lubricant should be inline with the bottom of the aperture. Top up the lubricant via the filler plug to a point where the oil starts to drip out of level plug aperture. Replace and tighten the plugs before using the machine. Gearbox oil should be replaced annually.

## Capacities & Lubricant

Gearbox; *1.2 Litre SAE90*

Half Shaft; *0.9 Litre SAE90*

## Flail replacement

The rotor and flails should be inspected for wear or damage on a regular basis – missing, damaged or worn flails should be replaced immediately. When replacing a flail the diametrically opposite flail should also be replaced at the same time in order to maintain rotor balance.

**DANGER: Machine and tractor should be switched off and the starting key removed at all times when inspecting or maintaining the machine – Never work on a machine that is switch on and running.**

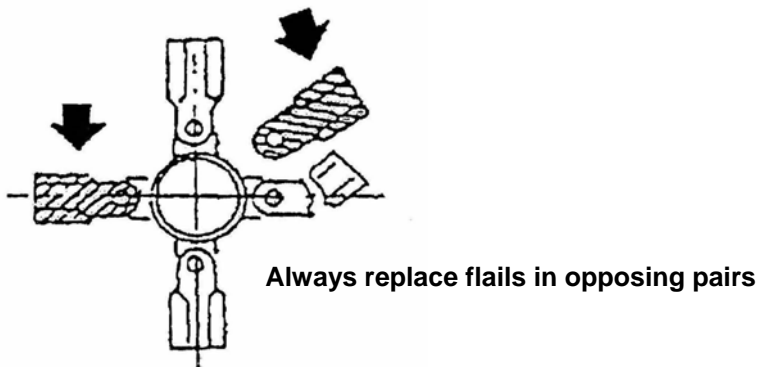

## Rotor Vibration

If vibration of the rotor is experienced the machine should be stopped immediately – this is often a sign that a flail is either missing or severely damaged, if this is the case do not use the machine until the problem has been rectified. If vibration continues, or occurs for no apparent reason, the rotor must be checked and, if necessary, rebalanced before using the machine again. Contact your local dealer for further advice or assistance on this subject.

## TROUBLESHOOTING

<b>PROBLEM</b>	<b>POSSIBLE CAUSES</b>	<b>REMEDIES</b>
<b>Irregular Cut</b>	Worn, bent or broken flails	<i>Replace flails</i>
	RPM too low	<i>Increase RPM</i>
	Machine not level to the ground	<i>Correct mounting on tractor</i>
	Clogged material caused by excessive forward speed	<i>Reduce forward speed</i>
<b>Noise</b>	Loose bolts	<i>Check and tighten bolts</i>
	Damaged components	<i>Repair or replace</i>
<b>Noisy gearbox</b>	Lack of lubrication	<i>Top up oil to correct level</i>
	Worn gears	<i>Replace worn components</i>
	Worn bearings	<i>Replace worn components</i>
<b>Vibration</b>	Broken, worn or missing flails	<i>Replace flails</i>
	Rotor out of balance	<i>Balance or replace rotor</i>
	Worn rotor bearings	<i>Replace rotor bearings</i>
<b>Excessive backlash in joints</b>	Worn pins	<i>Replace pins</i>
<b>Tight bearings</b>	Bearings dirty or ungreased	<i>Clean and grease</i>
	Violent lowering down of machine	<i>Lower machine gently</i>
<b>Belts overheating</b>	Belts slipping on pulleys	<i>Tension belts</i>
	Flails contacting the ground	<i>Raise cutting height</i>
	Working speed too high	<i>Reduce working speed</i>

### Machine Disposal

Disposal of this machine and any of its component parts must be performed in a responsible and inoffensive manner respecting all current laws relating to this subject. Materials forming this machine that must undergo differentiated division and disposal are:

- Steel
- Mineral Oil
- Rubber
- Plastic

# TORQUE SETTINGS FOR FASTENERS

The Chart below lists the correct tightening torque for fasteners. The Chart should be referred to when tightening or replacing bolts in order to determine the grade of bolt and the correct torque unless specific torque values are assigned in the text of the manual.

*Recommended torque is quoted in Foot-Pounds and Newton-Metres within this manual. The equation for conversion is 1 Nm. = 0.7376 ft.lbs.*

## TORQUE VALUES FOR IMPERIAL BOLTS

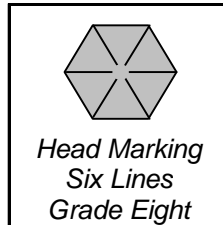
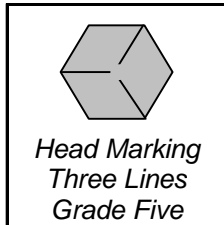
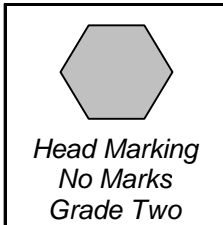

**NOTE:**  
The values in the chart apply to fasteners as received from the supplier, dry or when lubricated with normal engine oil. They DO NOT apply if special graphited, molydisulphide greases, or other extreme pressure lubricants are used. This applies to both UNF and UNC coarse threads.

Bolt Dia.
1/4"
5/16"
3/8"
7/16"
1/2"
9/16"
5/8"
3/4"
7/8"
1"
1-1/8"
1-1/4"
1-3/8"
1-1/2"

Value (Dry)	
ft.lb.	Nm.
5.5	7.5
11	15.0
20	27.0
32	43.0
50	68.0
70	95.0
100	135.0
175	240.0
175	240.0
270	360.0
375	510.0
530	720.0
700	950.0
930	1250.0

Value (Dry)	
ft.lb.	Nm.
9	12.2
18	25.0
33	45.0
52	70.0
80	110.0
115	155.0
160	220.0
280	380.0
450	610.0
675	915.0
850	115.0
1200	1626.0
1550	2100.0
2100	2850.0

Value (Dry)	
ft.lb.	Nm.
12.5	17.0
26	35.2
46	63.0
75	100.0
115	155.0
160	220.0
225	305.0
400	540.0
650	880.0
975	1325.0
1350	1830.0
1950	2650.0
2550	3460.0
3350	4550.0

## TORQUE VALUES FOR METRIC BOLTS.

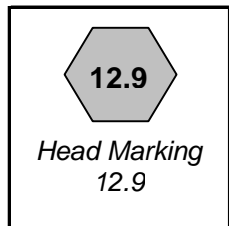
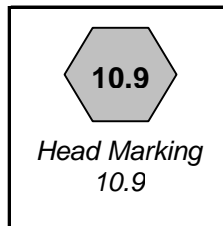
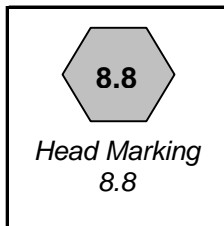
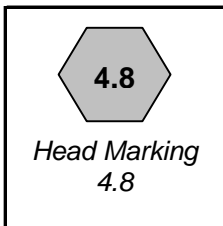

Bolt Dia.
6mm
8mm
10mm
12mm
14mm
16mm
18mm
20mm
22mm
24mm
27mm
30mm

Value (Dry)	
ft.lb.	Nm.
4.5	6.1
11	14.9
21	28.5
37	50.2
60	81.4
92	125.0
125	170.0
180	245.0
250	340.0
310	420.0
450	610.0
625	850.0

Value (Dry)	
ft.lb.	Nm.
8.5	11.5
20	27.1
40	54.2
70	95.0
110	150.0
175	240.0
250	340.0
350	475.0
475	645.0
600	810.0
875	1180.0
1200	1626.0

Value (Dry)	
ft.lb.	Nm.
12	16.3
30	40.1
60	81.4
105	140.0
165	225.0
255	350.0
350	475.0
500	675.0
675	915.0
850	1150.0
1250	1700.0
1700	2300.0

Value (Dry)	
ft.lb.	Nm.
14.5	20.0
35	47.5
70	95.0
120	160.0
190	260.0
300	400.0
410	550.0
580	790.0
800	1090.0
1000	1350.0
1500	2000.0
2000	2700.0







McConnel Limited, Temeside Works, Ludlow, Shropshire SY8 1JL. England.  
Telephone: 01584 873131. Facsimile: 01584 876463. [www.mcconnel.com](http://www.mcconnel.com)