

Publication 741
April 2013
Part No. 22675.41



Artemis Lite Variable Rate Drill Control Operation Manual

For use with McConel

SEEDAERATOR

Issue and use in conjunction with Publication 740 (Part No. 22675.40)

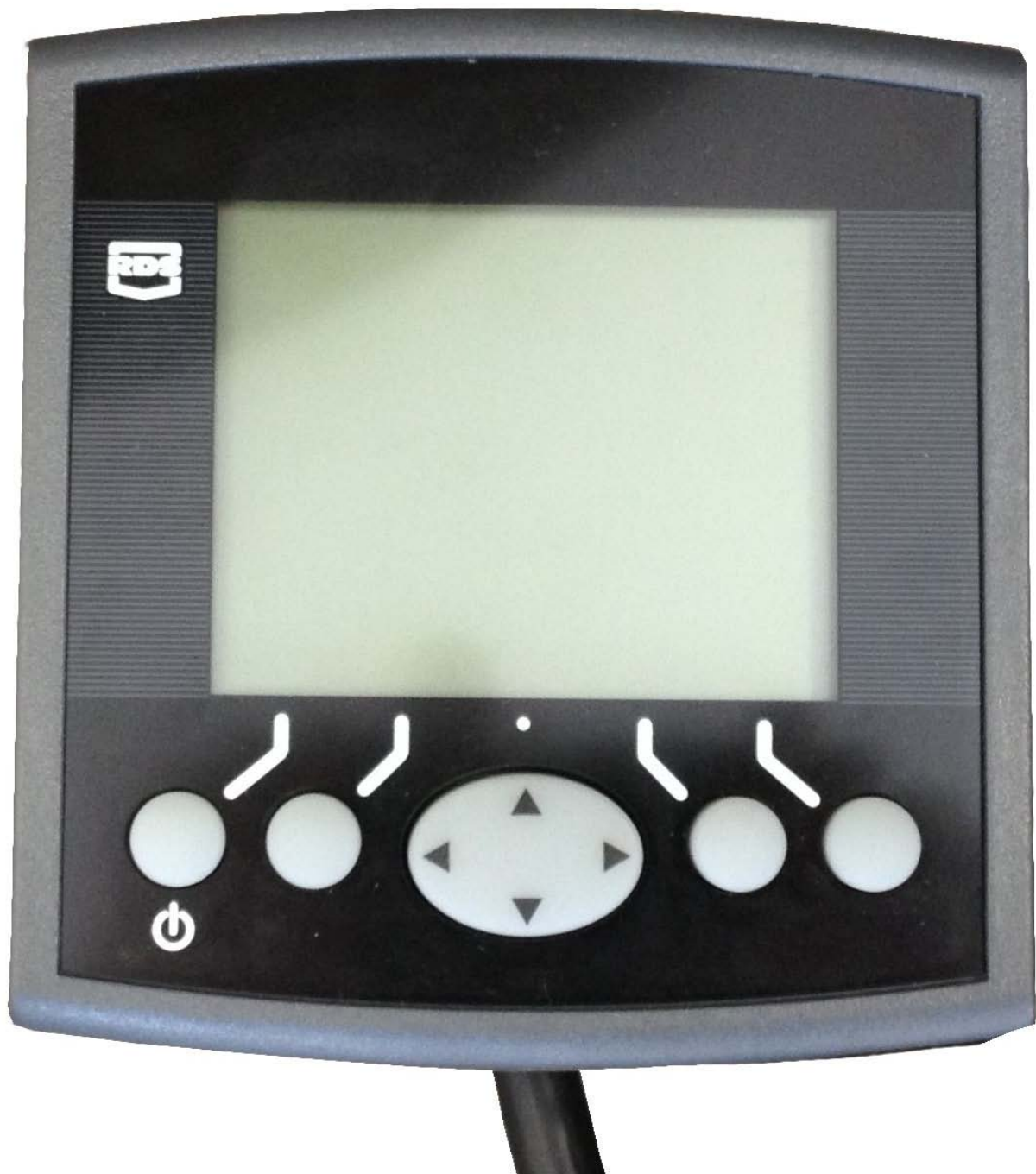

Artemis Lite

Variable Rate Drill Control

Operation

RDS Part No.:	S/DC/500-10-627
Document Issue:	1.1 : 21.8.12
Software Issue:	GW104-002 rev 9

Electromagnetic Compatibility (EMC)



This product complies with Council Directive 2004/108/EEC when installed and used in accordance with the relevant instructions.

IMPORTANT, READ THIS BEFORE USING THE ARTEMIS LITE

The Artemis Lite installation is a part of the Precision Farming System ("the System"). It is very important that you follow the described calibration procedures before operating the Artemis Lite instrument. Calibration and operation of the Artemis Lite must be in accordance with these instructions. Use of the System is subject to the following disclaimer;

1. So far as is legally permissible RDS Technology ("RDS"), or its distributors, shall not be liable, whatever the cause, for any increased costs, loss of profits, business, contracts, income, or anticipate savings or for any special, indirect or inconsequential damage whatsoever (death or personal injury excluded).
2. The capabilities and functions of the Precision Farming System ("the System") are limited as set out in the specification of the System, details of which are contained in the Help files and product literature and which must be read before using the System.
3. Without prejudice to the generality of the above it is hereby acknowledged that the System is not designed nor intended to a) originate variable treatment plans or b) achieve or avoid any application rate outside application parameters, which in both cases shall be the responsibility of the operator.
4. The standard terms and conditions of RDS (except clause 7), a copy of which is available on request, apply to the supply and operation of this System.

Service and Technical Support

PLEASE CONTACT YOUR NEAREST RDS DISTRIBUTOR if unknown then contact RDS Technology Ltd for further information,

Tel : +44 (0) 1453 733300

Fax : +44 (0) 1453 733311

e-mail : info@rdstec.com

web : www.rdstec.com

Our policy is one of continuous improvement and the information in this document is subject to change without notice. Check that the software reference matches that displayed by the instrument.

© Copyright RDS Technology Ltd 2012

UK627110.DOC

1.	OVERVIEW	4
1.1	<i>The Artemis Lite system</i>	4
1.2	<i>Main functions</i>	5
1.3	<i>Control Modes</i>	5
	Automatic Control Mode	5
1.4	<i>Menu keys</i>	5
2.	OPERATION	6
2.1	<i>Status Indicators</i>	6
2.2	<i>'MAIN' screen</i>	6
	2.2.1 Forward speed display and alarm functions	7
	Display smoothing	7
	Speed alarms on MAIN screen	7
	Maximum speed reminder	7
	2.2.2 Tramlining status/functions	7
	2.2.3 Advancing the bout number	8
	2.2.4 Holding the bout number	8
2.3	<i>'RATE' screen</i>	8
	2.3.1 Setting /overriding the target rate	8
2.4	<i>'INFO' screen</i>	9
2.5	<i>Tramlining</i>	9
2.6	<i>Pre-start function</i>	10
2.7	<i>Metering motor – manual override</i>	11
2.8	<i>Product calibration</i>	11
	2.8.1 Initial product calibration	11
2.9	<i>Set Fan Speed and Hopper Level alarm thresholds</i>	12
2.10	<i>Speed simulation</i>	13
2.11	<i>Select units / Rate step%</i>	13

1. Overview

1.1 The Artemis Lite system

Figure 1

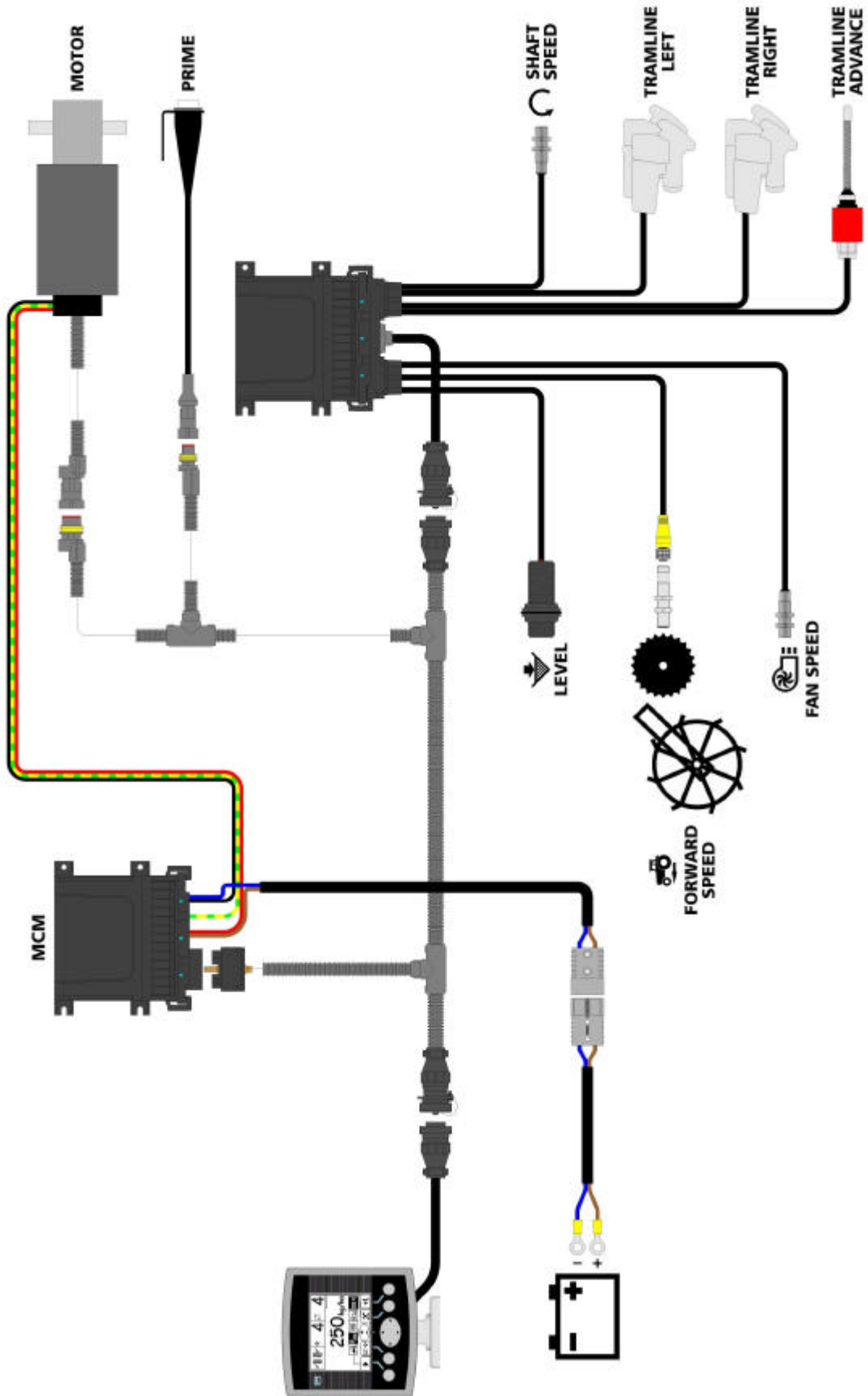

Figure 1 illustrates the various components of a typical, Artemis Lite installation.

Some screen pages vary slightly according to the instrument setup as shown above. Look for the above symbols next to the text.

1.2 Main functions

The Artemis is designed to allow automatic, variable rate control of any drill utilising Accord type metering units. You can at any time, also manually override the predetermined rate as field conditions require.

The basic functions are:

- ?? On The Move Rate Control
- ?? Tramlane Control
- ?? Forward Speed Alarms
- ?? Hopper Level alarm
- ?? Fan Speed & alarm
- ?? Information totals

The instrument has a special software routine that makes calibration of the metering unit very easy. In the calibration mode each metering unit is controlled via a 'priming switch' to dispense the product (figure 1).

During normal operation the control system is started and stopped automatically via a magnetic sensor as the drill is put into and taken out of work. Depending on the particular installation, this sensor is triggered either by the operation of the landwheel or the markers.

1.3 Control Modes

Automatic Control Mode

The application rate is automatically regulated as forward speed varies, to ensure that the actual application rate constantly matches a preset target rate. The application rate can be manually nudged up and down from the target rate as required.

1.4 Menu keys

All instrument functions are accessed by five keys below the LCD display.

There are three primary screens MAIN, RATE and INFO for normal operating functions, and a SETUP screen for calibration functions. These are selected by using the 'Screen Select' key and scrolling through each screen.

2. Operation

2.1 Status Indicators

All the operating screens have a status bar at the top of screen displaying the time as well as a number of different icons. These icons indicate the following:

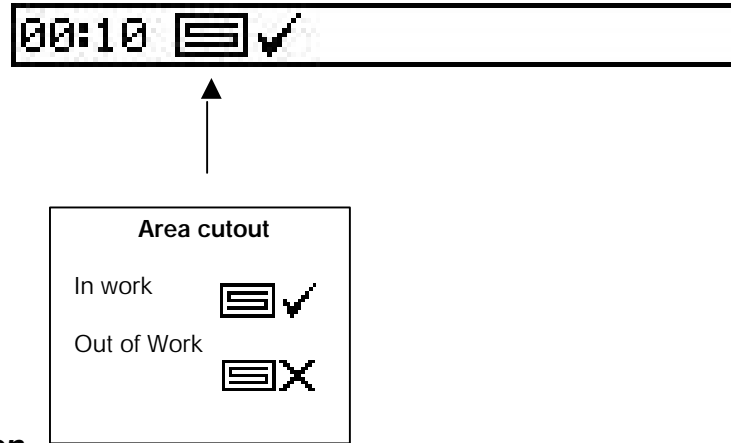

2.2 'MAIN' screen

The instrument will always default to the MAIN screen on startup. The MAIN screen is divided into 5 sections displaying the following functions,

Figure 2: MAIN screen

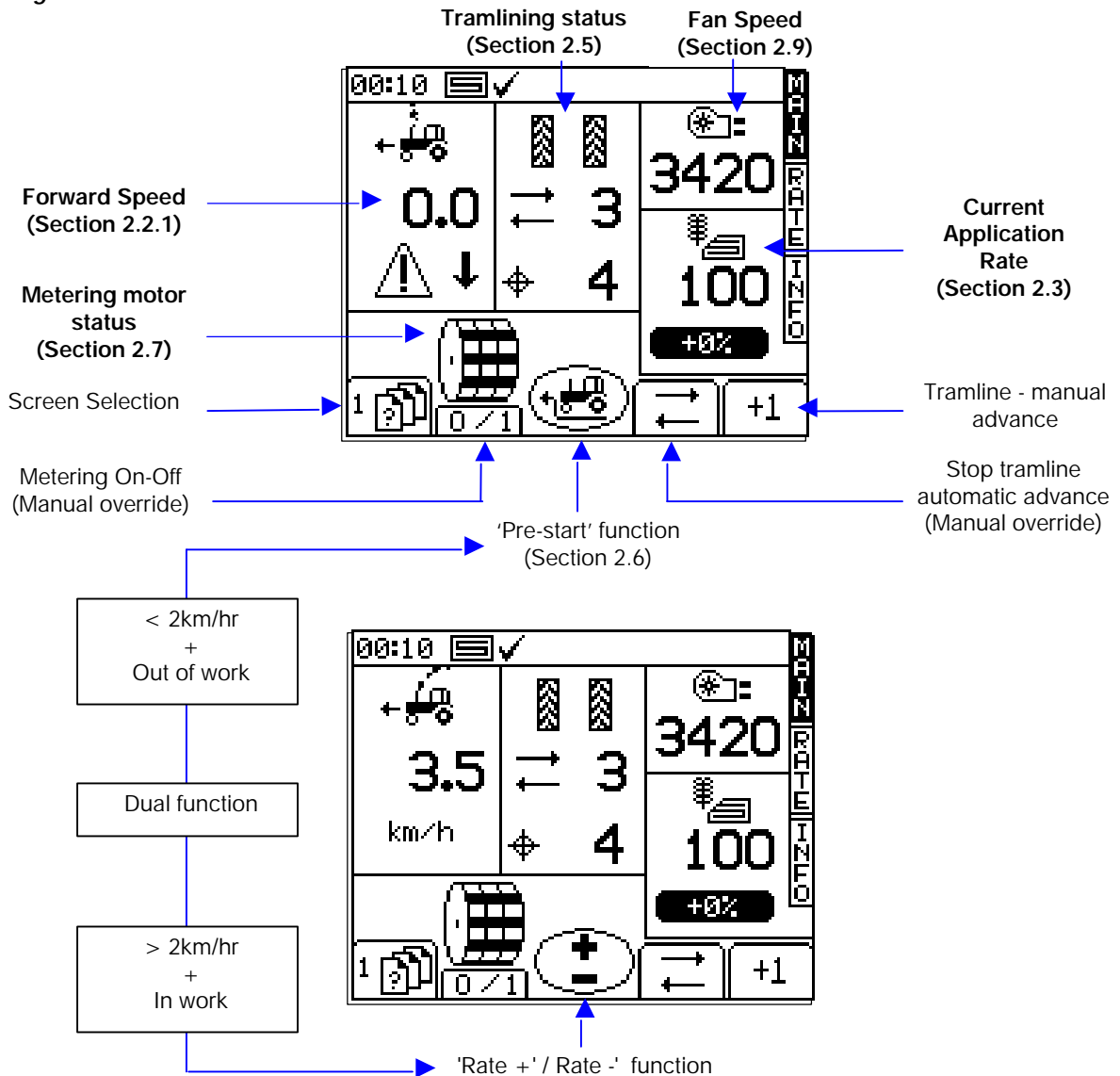

2.2.1 Forward speed display and alarm functions

Display smoothing

Except for sudden changes in speed, the forward speed displayed at any moment will be the average speed calculated over 3 seconds.

Speed alarms on MAIN screen

The instrument is programmed with low and high forward speed alarms.

If the drill is in work and the speed is less than 0.5 km/h then this section of the MAIN display will flash the following warning and the audible alarm will beep.

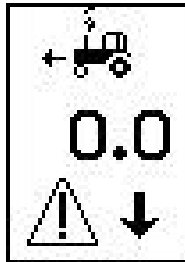

If the drill is in work and the speed is above the maximum that proportional control can achieve (indicated on the RATE screen), then this section of the MAIN display will flash the following warning and the audible alarm will beep.

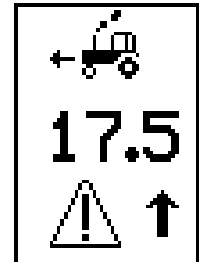

Maximum speed reminder

When setting a new target rate on the RATE screen, the instrument re-calculates and displays the maximum forward speed at which that rate can be maintained (fig.5). It is calculated from the rate set, drill working width, current calibration factor, gearbox ratio and maximum motor speed.

Figure 5

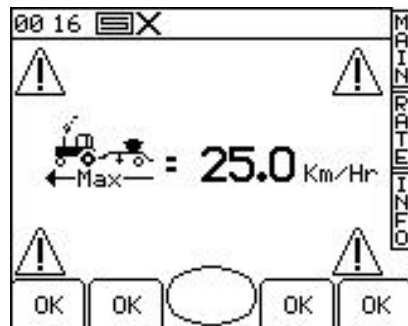

Simply press the key to return to the RATE screen.

NOTE: If the speed is too low, the operator must open the metering unit and re-calibrate to increase the calibration factor (ref. the 'Calibration' manual).

2.2.2 Tramlining status/functions

The MAIN screen shows the current status of tramlining.

Tramline rhythm:-

Symmetrical

Assymmetrical left

Assymetrical Right

Output status
(= ON)

Current bout

Target no. of bouts

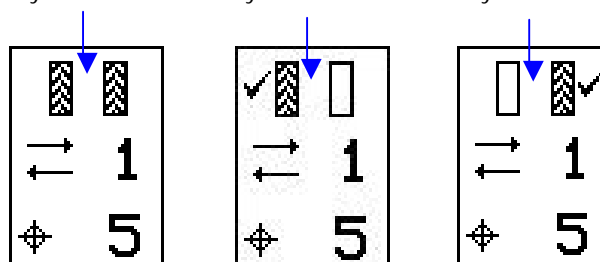

2.2.3 Advancing the bout number

On starting up the instrument the tramline sequence always starts at '1'.

If necessary, press the  key to select the correct current bout number, e.g. if entering work on a bout other than bout 1 of the tramline sequence.

2.2.4 Holding the bout number

Press the  key to hold the current bout number (e.g. to prevent the bout no. advancing if it is necessary to take the drill out of work, or depending on the drill setup - lift a marker, to negotiate a field feature).

The  icon indicates that the bout no. is held. Press the  key to resume normal bout advance.

NOTE: The tramlining sequence is set up via the SETUP page (ref. section 2.5).

2.3 'RATE' screen

This screen allows the drilling rate to be adjusted. Either kg/ha or seeds/m² units can be set via the SETUP menu.

Figure 6: RATE screen

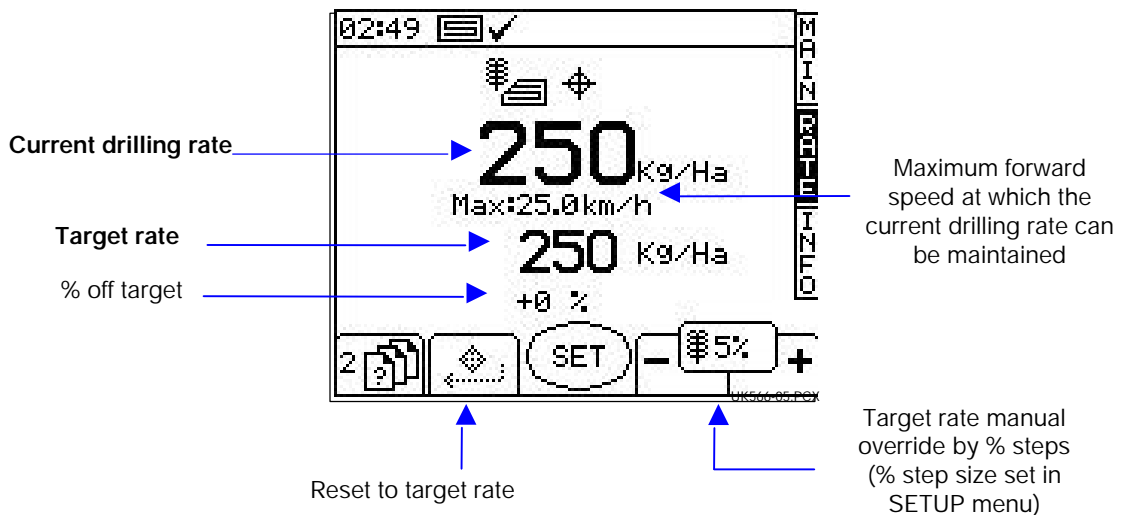



2.3.1 Setting /overriding the target rate

To set the target rate, simply enter the value and press the SET key to confirm.

The application rate on the MAIN screen is the same as that shown on the RATE screen above. If however on the rate screen, the current rate is manually adjusted above or below the target rate, then this number will flash (on for 1 second, off for 0.5 second).

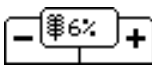
When operating from a treatment plan, then this number should only flash if the instructed rate has been changed using the '+' or '-' percentage buttons on the rate screen.

To override the target rate, use the  keys. The % step is configured from the SETUP menu.

To return to the target rate, press the  key.

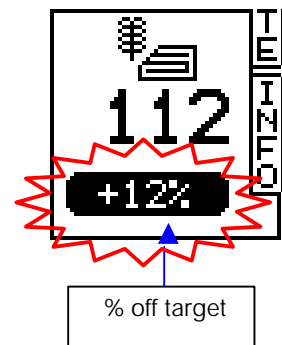

NOTE: Above a forward speed threshold of 2km/hr and when the implement is switched into work, the rate can also be conveniently "nudged" up or down by the preset % step, via the centre button on the MAIN screen display.

2.4 'INFO' screen

Figure 8

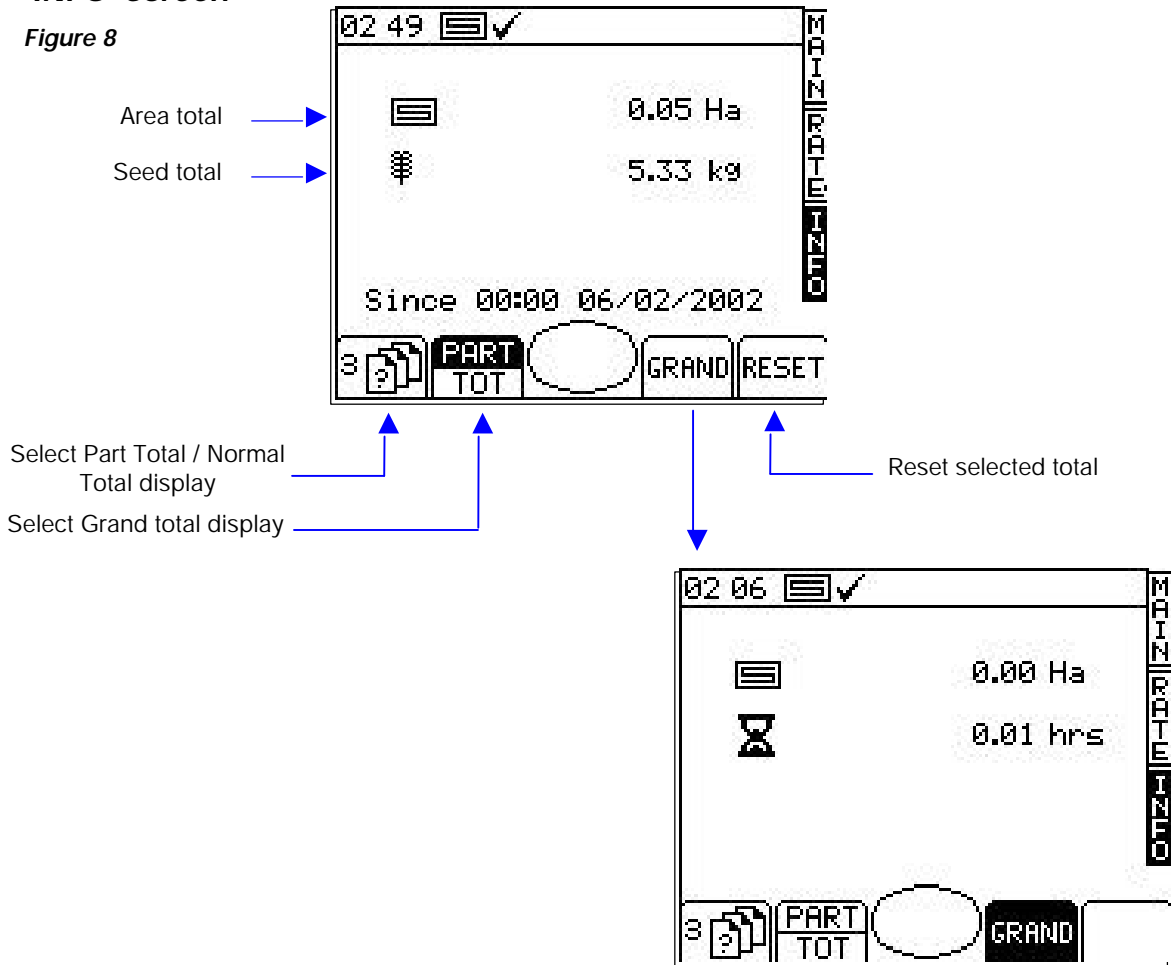

2.5 Tramlining

To set the desired tramline rhythm, select the SETUP screen and press the  key.

Figure 9



The target no. of bouts can be selected up to 10, with, symmetrical, asymmetrical left or asymmetrical right rhythm selectable.

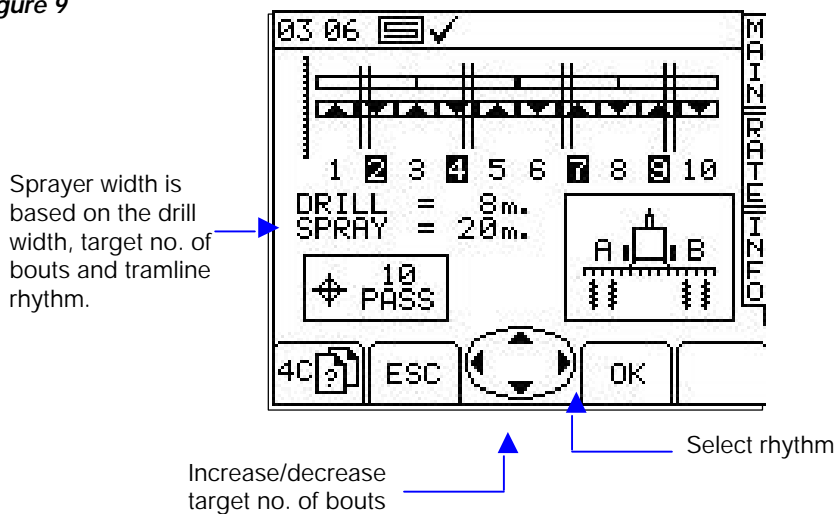
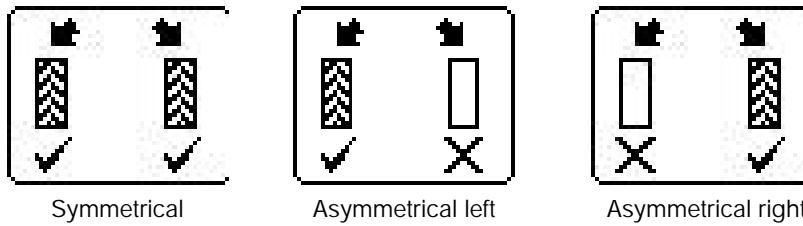

The instrument displays the drill/sprayer width combination for the selected target no. of bouts.

Beyond 10 bouts, a number of special asymmetric rhythms can be selected to suit the following drill/sprayer width combinations.

- '8-pass' 4m drill/10.7m sprayer, 4.5m drill/12m sprayer
- '10-pass' 4m drill/10m sprayer, 6m drill/15m sprayer
- '10-pass' 4m drill/13.3m sprayer, 6m drill/20m sprayer
- '14-pass' 3m drill/14 sprayer, 4m drill/18.7m sprayer
- '16-pass' 4m drill/21.3m sprayer, 4.5m drill/24m sprayer
- '18-pass' 4m drill/18m sprayer
- '22-pass' 4m drill/29.3m sprayer

The tramline sequences ('L' – Left, 'R' – Right) are as follows:

Bout	8-pass	10-pass	10-pass	14-pass	16-pass	18-pass	22-pass
1							
2	R	R	L				
3				L	R	L	
4	L	L					L
5	L		R				
6			R				
7	R	L		R		R	
8				R	L		
9		R	L		L		
10							
11							R
12				L		R	R
13							
14					R		
15							
16						L	
17							
18							
19							L
20							
21							
22							

2.6 Pre-start function



Particularly useful in the case of a front-mounted hopper, the pre-start function helps to avoid an un-seeded area on entering work. It starts the metering unit at the calibration speed while the drill is still stationary, and 'primes' the drill so that the seed reaches the coulters just as the drill enters work.

The pre-start settings are established by trial and error tests when the system is first set up, and are adjusted via the calibration menu.

To use the pre-start feature, simply press the  key on the MAIN screen before moving off.

The metering motor will run at the calibration speed for a preset time limit, or until the forward speed exceeds 2km/hr, when full proportional control then takes over.

NOTE: The centre button has a dual function. It has the "Pre-start" function below 2km/hr and the implement is out of work. When the forward speed is more than 2km/hr and the implement is switched into work, the function changes to "Rate + / Rate -".

2.7 Metering motor – manual override

Simply press the  key on the MAIN page



The metering motor(s) can be stopped manually as desired, eg:

- (a) An area of field needs further cultivation before seeding.
- (b) In the case of a front-mounted hopper, the metering motor is switched off just before the end of the bout to clear the seed through (the opposite of the 'pre-start function).

2.8 Product calibration

2.8.1 Initial product calibration

Set up the drill in the usual way for a bucket test.

1. From the SETUP screen, press the  key.
2. Select the desired units then enter the weight required to be metered out (fig.12) and press ENTER. The metering unit will then operate at the programmed calibration speed to dispense the correct amount of product, then stops. The instrument then displays a weight figure *based on the existing programmed product calibration factor*.

NOTE: If a priming switch is employed for calibration the calibration routine will commence from fig. 13.

3. Weigh the contents of the container, and then enter the *ACTUAL* weight dispensed (fig. 14) and press ENTER to confirm.

Figure 12

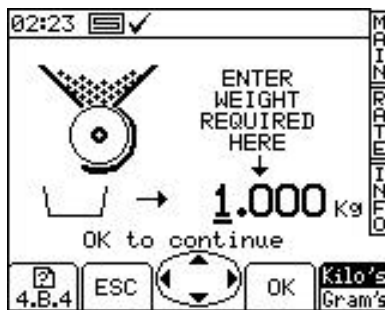

Figure 13

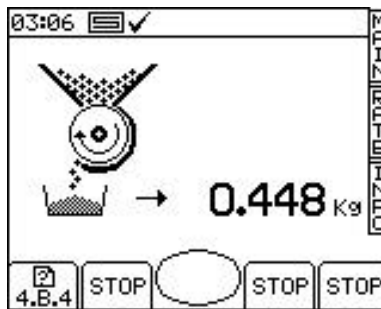
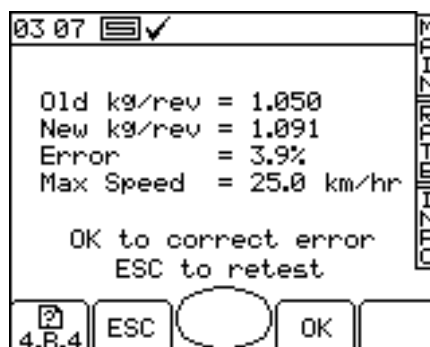

Figure 14



4. Press ENTER again for the instrument to re-calculate and display the new calibration factor in kg/rev, the error %, and the maximum forward speed that is permissible based on the application rate set for the product (fig.15).

Figure 15



- Press ENTER again to confirm and store the new calibration factor, or press ESC to return to the SETUP menu screen.

It is recommended to reset the PART TOTAL to zero before commencing drilling. This will enable you after drilling an area, to quantify any error in the calibration factor by logging the theoretical amount of product used against a known amount used (a whole bag for example).

You can then adjust the calibration factor precisely, if necessary (section 2.5.2).

NOTE: Systems fitted to 'Accord' type metering mechanisms.

When changing from a low rate to a high rate i.e. 3kg/ha to 100kg/ha use the following procedure:

- Move the metering slide to a position for the higher rate.
- Operate the product calibration routine, dispense a suitable amount of product and enter the weight gained. The error will be considerable but press enter to correct the calibration factor and continue (see FIG 15).
- Now program the required application rate (see SECTION 2.3).
- Perform the product calibration routine again, the error this time will be marginal. Accept the error and begin drilling.

When changing from a high rate to a low rate i.e. 100kg/ha to 3kg/ha use the following procedure:

- Move the metering slide to a position for the lower rate.
- Operate the product calibration routine and enter the weight gained. If using the priming switch simply dispense a small amount of product and enter the weight. The error will be considerable but press enter to correct the calibration factor and continue (see FIG 15).
- Now program the required application rate (see SECTION 2.3).
- Perform the product calibration routine again this time dispensing a suitable amount of product. The error this time will be marginal. Accept the error and begin drilling.

2.9 Set Fan Speed and Hopper Level alarm thresholds

To view the alarm thresholds (fig. 19), from the SETUP menu, press the  key.

Figure 19



To adjust the threshold, simply enter the figure using the arrow keys and press the OK key.

2.10 Speed simulation

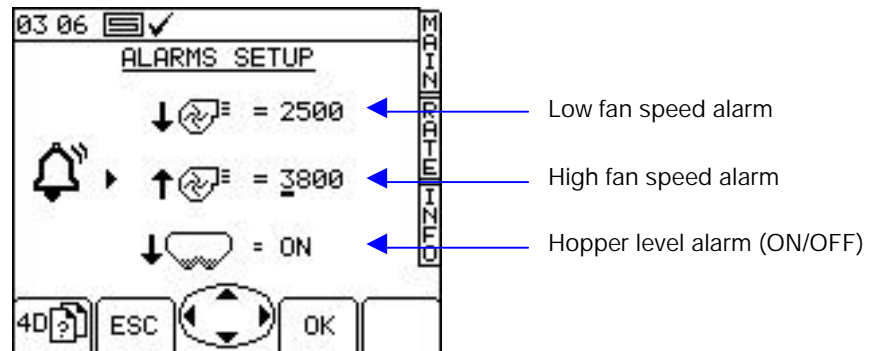
If the radar speed sensor stops working, you can continue drilling by simulating a forward speed signal. Remember though that your actual forward speed should match the simulated speed as close as possible, otherwise the drilling rate will not be correct. Drive faster than the simulated speed and you will under-apply, and vice-versa.

To set the simulated forward speed, from the SETUP screen, select  then 'Forward Speed Sensor'.

Press the  key (fig.20), then enter the desired sim. speed (fig. 21).

Press the ENTER key again to start speed simulation.

Figure 20

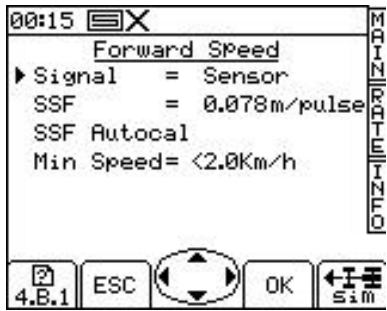
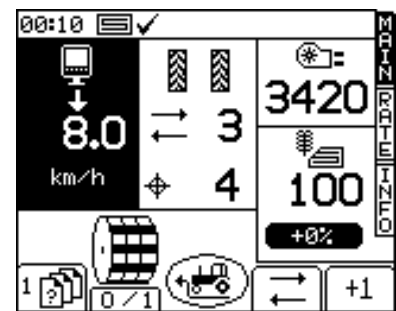

Figure 21



Figure 22



As long as speed simulation is running, the forward speed display on the MAIN screen will flash (fig. 22)

NOTE: The pre-start function works as normal with a simulated speed.

2.11 Select units / Rate step%

From the SETUP screen, select '1 User Setup' then '2. Customise'.

Figure 23



Use the UP/DOWN arrow keys to select the parameter.

Use the LEFT/RIGHT arrow key to select the units (kg/ha or seeds/m²).

Use either the LEFT/RIGHT arrow keys to adjust the rate, or simply enter the desired figure using the keypad and press ENTER to confirm.

Document History

Issue 1:	28.10.10	Original issue
Issue 1.1	21.8.12	Section 2.10 - revised for S/W ver. GW104-002 rev 9



McConnel Limited, Temeside Works, Ludlow, Shropshire SY8 1JL. England.
Telephone: 01584 873131. Facsimile: 01584 876463. www.mcconnel.com