

Publication 455
September 2008
Part No. 41570.55
Revision: 14.06.13

SHEARTRIM

1.5M STANDARD DUTY CUTTERBAR



Operator & Parts Manual

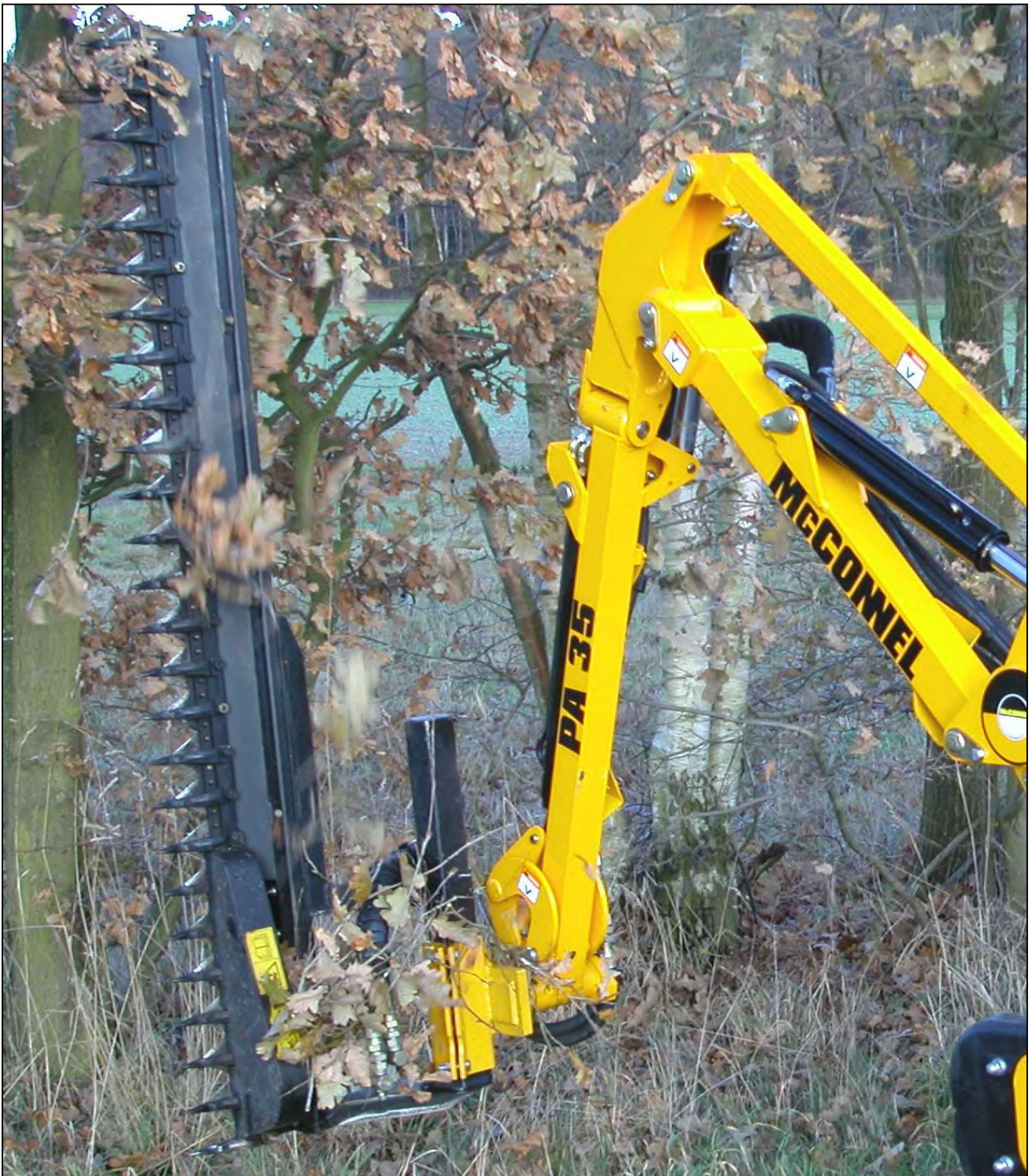

IMPORTANT

VERIFICATION OF WARRANTY REGISTRATION



Dealer Warranty Information & Registration Verification

It is imperative that the selling dealer registers this machine with McConnel Limited before delivery to the end user – failure to do so may affect the validity of the machine warranty.

To register machines; log onto <https://my.mcconnel.com> and select 'Machine Registration' which can be found in the 'Warranty' section of the site. **Confirm to the customer that the machine has been registered by completing the verification form below.**

Registration Verification	Serial No. <input type="text"/>
Dealer Name:	
Dealer Address:	
Customer Name:	
Date of Warranty Registration:/...../.....	Dealer Signature:

Note to Customer / Owner

Please ensure the section above has been completed and signed by the dealer to verify your machine has been registered with McConnel Limited.

IMPORTANT: During the initial 'bedding in' period of a new machine it is the customer's responsibility to regularly inspect all nuts, bolts and hose connections for tightness and re-tighten if required. New hydraulic connections occasionally weep small amounts of oil as the seals and joints settle in – where this occurs it can be cured by re-tightening the connection – *refer to torque settings chart below*. The tasks stated above should be performed on an hourly basis during the first day of work and at least daily thereafter as part of the machine's general maintenance procedure.

CAUTION: DO NOT OVER TORQUE HYDRAULIC FITTINGS AND HOSES

Torque Settings for Hydraulic Fittings

Hydraulic Hose Ends		
BSP	Setting	Metric
1/4"	18 Nm	19 mm
3/8"	31 Nm	22 mm
1/2"	49 Nm	27 mm
5/8"	60 Nm	30 mm
3/4"	80 Nm	32 mm
1"	125 Nm	41 mm
1.1/4"	190 Nm	50 mm
1.1/2"	250 Nm	55 mm
2"	420 Nm	70 mm

Port Adaptors with Bonded Seals		
BSP	Setting	Metric
1/4"	34 Nm	19 mm
3/8"	47 Nm	22 mm
1/2"	102 Nm	27 mm
5/8"	122 Nm	30 mm
3/4"	149 Nm	32 mm
1"	203 Nm	41 mm
1.1/4"	305 Nm	50 mm
1.1/2"	305 Nm	55 mm
2"	400 Nm	70 mm

WARRANTY POLICY

WARRANTY REGISTRATION

All machines must be registered, by the selling dealer with McConnel Ltd, before delivery to the end user. On receipt of the goods it is the buyer's responsibility to check that the Verification of Warranty Registration in the Operator's Manual has been completed by the selling dealer.

1. LIMITED WARRANTIES

- 1.01. *All mounted machines supplied by McConnel Ltd are warranted to be free from defects in material and workmanship from the date of sale to the original purchaser for a period of 12 months, unless a different period is specified.
All Self Propelled Machines supplied by McConnel Ltd are warranted to be free from defects in material and workmanship from the date of sale to the original purchaser for a period of 12 months or 1500 hours. Engine warranty will be specific to the Manufacturer of that unit.*
- 1.02. *All spare parts supplied by McConnel Ltd and purchased by the end user are warranted to be free from defects in material and workmanship from the date of sale to the original purchaser for a period of 6 months. All parts warranty claims must be supported by a copy of the failed part invoice to the end user. We cannot consider claims for which sales invoices are not available.*
- 1.03. *The warranty offered by McConnel Ltd is limited to the making good by repair or replacement for the purchaser any part or parts found, upon examination at its factory, to be defective under normal use and service due to defects in material or workmanship. Returned parts must be complete and unexamined. Pack the component(s) carefully so that any transit damage is avoided. All ports on hydraulic items should be drained of oil and securely plugged to prevent seepage and foreign body ingress. Certain other components, electrical items for example, may require particular care when packing to avoid damage in transit.*
- 1.04. *This warranty does not extend to any product from which McConnel Ltd's serial number plate has been removed or altered.*
- 1.05. *The warranty policy is valid for machines registered in line with the terms and conditions detailed and on the basis that the machines do not extend a period of 24 months or greater since their original purchase date, that is the original invoice date from McConnel Limited.
Machines that are held in stock for more than 24 months cannot be registered for warranty.*
- 1.06. *This warranty does not apply to any part of the goods, which has been subjected to improper or abnormal use, negligence, alteration, modification, fitment of non-genuine parts, accident damage, or damage resulting from contact with overhead power lines, damage caused by foreign objects (e.g. stones, iron, material other than vegetation), failure due to lack of maintenance, use of incorrect oil or lubricants, contamination of the oil, or which has served its normal life. This warranty does not apply to any expendable items such as blades, belts, clutch linings, filter elements, flails, flap kits, skids, soil engaging parts, shields, guards, wear pads, pneumatic tyres or tracks.*
- 1.07. *Temporary repairs and consequential loss - i.e. oil, downtime and associated parts are specifically excluded from the warranty.*
- 1.08. *Warranty on hoses is limited to 12 months and does not include hoses which have suffered external damage. Only complete hoses may be returned under warranty, any which have been cut or repaired will be rejected.*
- 1.09. *Machines must be repaired immediately a problem arises. Continued use of the machine after a problem has occurred can result in further component failures, for which McConnel Ltd cannot be held liable, and may have safety implications.*
- 1.10. *If in exceptional circumstances a non McConnel Ltd part is used to effect a repair, warranty reimbursement will be at no more than McConnel Ltd's standard dealer cost for the genuine part.*

- 1.11. *Except as provided herein, no employee, agent, dealer or other person is authorised to give any warranties of any nature on behalf of McConnell Ltd.*
- 1.12. *For machine warranty periods in excess of 12 months the following additional exclusions shall apply:*
 - 1.12.1. *Hoses, exposed pipes and hydraulic tank breathers.*
 - 1.12.2. *Filters.*
 - 1.12.3. *Rubber mountings.*
 - 1.12.4. *External electric wiring.*
 - 1.12.5. *Bearings and seals*
 - 1.12.6. *External Cables, Linkages*
 - 1.12.7. *Loose/Corroded Connections, Light Units, LED's*
 - 1.12.8. *Comfort items such as Operator Seat, Ventilation, Audio Equipment*
- 1.13. *All service work, particularly filter changes, must be carried out in accordance with the manufacturer's service schedule. Failure to comply will invalidate the warranty. In the event of a claim, proof of the service work being carried out may be required.*
- 1.14. *Repeat or additional repairs resulting from incorrect diagnosis or poor quality previous repair work are excluded from warranty.*

NB Warranty cover will be invalid if any non-genuine parts have been fitted or used. Use of non-genuine parts may seriously affect the machine's performance and safety. McConnell Ltd cannot be held responsible for any failures or safety implications that arise due to the use of non-genuine parts.

2. REMEDIES AND PROCEDURES

- 2.01. *The warranty is not effective unless the Selling Dealer registers the machine, via the McConnell web site and confirms the registration to the purchaser by completing the confirmation form in the operator's manual.*
- 2.02. *Any fault must be reported to an authorised McConnell Ltd dealer as soon as it occurs. Continued use of a machine, after a fault has occurred, can result in further component failure for which McConnell Ltd cannot be held liable.*
- 2.03. *Repairs should be undertaken within two days of the failure. Claims submitted for repairs undertaken more than 2 weeks after a failure has occurred, or 2 days after the parts were supplied will be rejected, unless the delay has been authorised by McConnell Ltd. Please note that failure by the customer to release the machine for repair will not be accepted as a reason for delay in repair or submitting warranty claims.*
- 2.04. *All claims must be submitted, by an authorised McConnell Ltd Service Dealer, within 30 days of the date of repair.*
- 2.05. *Following examination of the claim and parts, McConnell Ltd will pay, at their discretion, for any valid claim the invoiced cost of any parts supplied by McConnell Ltd and appropriate labour and mileage allowances if applicable.*
- 2.06. *The submission of a claim is not a guarantee of payment.*
- 2.07. *Any decision reached by McConnell Ltd. is final.*

3. LIMITATION OF LIABILITY

- 3.01. *McConnell Ltd disclaims any express (except as set forth herein) and implied warranties with respect to the goods including, but not limited to, merchantability and fitness for a particular purpose.*
- 3.02. *McConnell Ltd makes no warranty as to the design, capability, capacity or suitability for use of the goods.*
- 3.03. *Except as provided herein, McConnell Ltd shall have no liability or responsibility to the purchaser or any other person or entity with respect to any liability, loss, or damage caused or alleged to be caused directly or indirectly by the goods including, but not limited to, any indirect, special, consequential, or incidental damages resulting from the use or operation of the goods or any breach of this warranty. Notwithstanding the above limitations and warranties, the manufacturer's liability hereunder for damages incurred by the purchaser or others shall not exceed the price of the goods.*
- 3.04. *No action arising out of any claimed breach of this warranty or transactions under this warranty may be brought more than one (1) year after the cause of the action has occurred.*

4. MISCELLANEOUS

- 4.01. *McConnel Ltd may waive compliance with any of the terms of this limited warranty, but no waiver of any terms shall be deemed to be a waiver of any other term.*
- 4.02. *If any provision of this limited warranty shall violate any applicable law and is held to be unenforceable, then the invalidity of such provision shall not invalidate any other provisions herein.*
- 4.03. *Applicable law may provide rights and benefits to the purchaser in addition to those provided herein.*

McConnel Limited

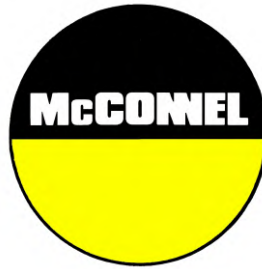

For Safety and Performance...

ALWAYS READ THE BOOK FIRST

McCONEL LIMITED

**Temeside Works
Ludlow
Shropshire
England**

**Telephone: +44 (0)1584 873131
www.mcconel.com**

- NOISE STATEMENT -

The equivalent daily personal noise exposure from this machine measured at the operators' ear is within the range 78 – 85 dB, these figures apply to a normal distribution of use where the noise fluctuates between zero and maximum. The figures assume that the machine is fitted to a tractor with a 'quiet' cab with the windows closed in a generally open environment. We recommend that the windows are kept closed. With the cab rear window open the equivalent daily personal noise exposure will increase to a figure within the range 82 – 88 dB. At an equivalent daily noise exposure level of 85 – 90 dB ear protection is recommended and must always be used if any window is left open.



Operating, servicing and maintaining this equipment can expose you to chemicals including gasoline, diesel fuel, lubricants, petroleum products, engine exhaust, carbon monoxide, and phthalates, which are known to the State of California to cause cancer and birth defects or other reproductive harm. To minimize exposure, avoid breathing exhaust, do not idle the engine except as necessary, service your vehicle in a well-ventilated area and wear gloves or wash your hands frequently when servicing your vehicle. Battery posts, terminals and related accessories contain lead and lead compounds, chemicals known to the state of California to cause cancer, birth defects or other reproductive harm. For more information go to www.P65Warnings.ca.gov. This website, operated by California's Office of Environmental Health Hazard Assessment, provides information about these chemicals and how individuals may be exposed to them.

CONTENTS

Operation Section

General Information	1
Technical Specifications	2
Safety Information	3
Vehicle Preparation	8
Procedure for Use	9
Installation	9
Start Up & Operation	11
Working	11
Transportation of the Machine	11
Machine Removal	11
Maintenance	12
Troubleshooting	13

Parts Section

1.5M Cutterbar Assembly	16
1.5M Sheartrim Kit – <i>Swingtrim L/H builds</i>	18
1.5M Sheartrim Kit – <i>Swingtrim R/H builds</i>	20
1.5M Sheartrim Kit – <i>PA31 L/H builds</i>	22
1.5M Sheartrim Kit – <i>PA31 R/H builds</i>	23
1.5M Sheartrim Kit – <i>PA32, PA35, PA41 & MAG310 L/H builds</i>	24
1.5M Sheartrim Kit – <i>PA32, PA35, PA41 & MAG310 R/H builds</i>	25
1.5M Sheartrim Kit – <i>PA47, MAG390, MAG450 & MAG460 L/H builds</i>	26
1.5M Sheartrim Kit – <i>PA47, MAG390, MAG450 & MAG460 R/H builds</i>	27
1.5M Sheartrim Kit – <i>PA48, PA50, PA52FM, MAG480 & MAG520 L/H builds</i>	28
1.5M Sheartrim Kit – <i>PA48, PA50, PA52FM, MAG480 & MAG520 R/H builds</i>	30
1.5M Sheartrim Kit – <i>AG46, AG50, AG50+, MAG420 & MAG450S builds</i>	32

GENERAL INFORMATION

Read this manual before fitting or operating the machine or accessory. Whenever any doubt exists contact your local dealer or the McConnel Service Department for assistance.

Only use 'Genuine McConnel Parts' on McConnel machinery and equipment.

DEFINITIONS: *The following definitions apply throughout this manual;*

⚠ DANGER

DANGER: *Alerts to a hazardous situation which will result in death or serious injury if not observed carefully.*

⚠ WARNING

WARNING: *Alerts to a hazardous situation which could result in death or serious injury if not observed carefully.*

⚠ CAUTION

CAUTION: *Alerts to a hazardous situation which could result in damage to the machine and/or equipment if not observed carefully.*

NOTICE

NOTICE: *Specific or general information considered important or useful to emphasise.*

LEFT HAND (LH) & RIGHT HAND (RH): *These terms are applicable to the machine when fitted to the tractor and viewed from the rear; these terms also apply to tractor references.*

SERIAL PLATE

All machines are equipped with a serial number plate containing important information relating to the machine including a unique serial number used for identification purposes.

Note: Images in this manual are provided for instruction and informational purposes only and may not show components in their entirety. In certain instances images may appear different to the actual machine; where this occurs the general procedure will be basically the same. E&OE.

MACHINE & DEALER INFORMATION

Record the serial number of your machine on this page and always quote it when ordering parts. Whenever information concerning the machine is requested remember to also state the make and model of tractor to which the machine is fitted.	
Machine Serial Number:	Installation Date:
Machine Model Details:	
Dealer Name & Branch:	
Dealer Address:	
Dealer Telephone No:	
Dealer Email Address:	

TECHNICAL SPECIFICATIONS

<i>Oleodynamic working, orbit motor 159.2cc³</i>	
<i>Minimum Power Requirement</i>	<i>20hp (14.5kw)</i>
<i>Minimum Oil Flow</i>	<i>30 l/min</i>
<i>Maximum Oil Flow</i>	<i>60 l/min</i>
<i>Recommended Oil Flow</i>	<i>45 l/min</i>
<i>Minimum Pressure</i>	<i>20 bar</i>
<i>Maximum Pressure</i>	<i>100 bar</i>
<i>Working Temperature Range</i>	<i>-15°C to +80°C</i>
<i>Oil Viscosity</i>	<i>12 - 100 mm²/sec</i>
<i>Filtering Degree</i>	<i>25 – 30 µm</i>
<i>Minimum Frequency</i>	<i>185 rpm</i>
<i>Maximum Frequency</i>	<i>370 rpm</i>
<i>Minimum Cutting Area – per each section (tooth)</i>	<i>4mm²</i>
<i>Maximum Cutting Area – per each section (tooth)</i>	<i>300mm²</i>
<i>Maximum Global Cutting Area</i>	<i>500mm²</i>
<i>Suggested Feed Speed</i>	<i>2000 m/h (2Km/h)</i>
<i>Recommended Working Pressure – all models</i>	<i>70 bar</i>

Machine Identification

The machine is fitted with a Serial Number Plate stating the manufacturers name, machine code, serial number and weight. When ordering parts or requesting advice please quote the machine code and serial number as stated on this plate.

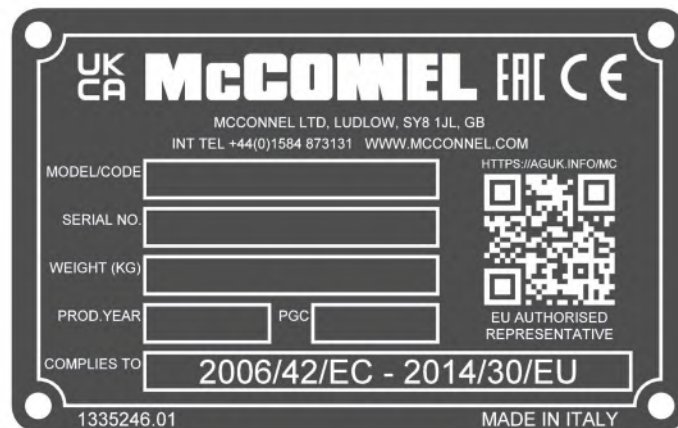



This machine has the potential to be extremely dangerous - in the wrong hands it can kill or maim; It is therefore imperative that both owner and operator of the machine reads and understands the following section to ensure they are fully aware of the dangers that do, or may exist, and their responsibilities surrounding the use and operation of the machine.

The operator of this machine is responsible not only for their own safety but equally for the safety of others who may come into the close proximity of the machine, as the owner you are responsible for both.

When the machine is not in use it should be lowered to rest on the ground. In the event of any fault being detected with the machine's operation it must be stopped immediately and not used again until the fault has been corrected by a qualified technician.

POTENTIAL DANGERS ASSOCIATED WITH THE USE OF THIS MACHINE:

- ▲ *Being hit by debris thrown by rotating components.*
- ▲ *Being hit by machine parts ejected through damage during use.*
- ▲ *Being caught on a rotating power take-off (PTO) shaft.*
- ▲ *Being caught in other moving parts i.e.: belts, pulleys and cutting heads.*
- ▲ *Electrocution from Overhead Power Lines (by contact with or 'flashover' from).*
- ▲ *Being hit by cutting heads or machine arms as they move.*
- ▲ *Becoming trapped between tractor and machine when hitching or unhitching.*
- ▲ *Tractor overbalancing when machine arm is extended.*
- ▲ *Injection of high-pressure oil from hydraulic hoses or couplings.*
- ▲ *Machine overbalancing when freestanding (out of use).*
- ▲ *Road traffic accidents due to collision or debris on the road.*

BEFORE USING THIS MACHINE YOU MUST:

- ▲ *Ensure you read all sections of the operator handbook.*
- ▲ *Ensure the operator is, or has been, properly trained to use the machine.*
- ▲ *Ensure the operator has been issued with and reads the operator handbook.*
- ▲ *Ensure the operator understands and follows the instructions in operator handbook.*
- ▲ *Ensure the tractor front, rear and sides are fitted with metal mesh or polycarbonate guards of suitable size and strength to protect the operator against thrown debris or parts.*
- ▲ *Ensure tractor guards are fitted correctly, are undamaged and kept properly maintained.*
- ▲ *Ensure that all machine guards are in position, are undamaged, and are kept maintained in accordance with the manufacturer's recommendations.*
- ▲ *Ensure flails and their fixings are of a type recommended by the manufacturer, are securely attached and that none are missing or damaged.*
- ▲ *Ensure hydraulic pipes are carefully and correctly routed to avoid damage by chaffing, stretching or pinching and that they are held in place with the correct fittings.*
- ▲ *Always follow the manufacturer's instructions for attachment and removal of the machine from the tractor.*
- ▲ *Check that the machine fittings and couplings are in good condition.*
- ▲ *Ensure the tractor meets the minimum weight recommendations of the machine's manufacturer and that ballast is used as necessary.*
- ▲ *Always inspect the work area thoroughly before starting to note obstacles and remove wire, bottles, cans and other debris.*
- ▲ *Use clear suitably sized warning signs to alert others to the nature of the machine working within that area. Signs should be placed at both ends of the work site. (It is recommended that signs used are of a size and type specified by the Department of Transport and positioned in accordance with their, and the Local Highways Authority, guidelines).*
- ▲ *Ensure the operator is protected from noise. Ear defenders should be worn and tractor cab doors and windows must be kept closed. Machine controls should be routed through proprietary openings in the cab to enable all windows to be shut fully.*
- ▲ *Always work at a safe speed taking account of the conditions i.e.: terrain, highway proximity and obstacles around and above the machine. Extra special attention should be applied to Overhead Power Lines. Some of our machines are capable of reach in excess of 8 metres (26 feet) this means they have the potential to well exceed, by possibly 3 metres (9' 9"), the lowest legal minimum height of 5.2 metres from the ground for 11,000 and 33,000 volt power lines. It cannot be stressed enough the dangers that surround this capability, it is therefore vital that the operator is fully aware of the maximum height and reach of the machine, and that they are fully conversant with all aspects regarding the safe minimum distances that apply when working with machines in close proximity to Power Lines. (Further information on this subject can be obtained from the Health & Safety Executive or your Local Power Company).*

- ▲ *Always disengage the machine, kill the tractor engine, remove and pocket the key before dismounting for any reason.*
- ▲ *Always clear up all debris left at the work area, it may cause hazard to others.*
- ▲ *Always ensure when you remove your machine from the tractor that it is left in a safe and stable position using the stands and props provided and secured if necessary.*

WHEN NOT TO USE THIS MACHINE:

- ▲ *Never attempt to use this machine if you have not been trained to do so.*
- ▲ *Never use a machine until you have read and understood the operator handbook, are familiar with it, and practiced the controls.*
- ▲ *Never use a machine that is poorly maintained.*
- ▲ *Never use a machine if guards are missing or damaged.*
- ▲ *Never use a machine on which the hydraulic system shows signs of wear or damage.*
- ▲ *Never fit, or use, a machine on a tractor that does not meet the manufacturer's minimum specification level.*
- ▲ *Never use a machine fitted to a tractor that does not have suitable front, rear and side(s) cab guarding made of metal mesh or polycarbonate.*
- ▲ *Never use the machine if the tractor cab guarding is damaged, deteriorating or badly fitted.*
- ▲ *Never turn a machine cutting head to an angle that causes debris to be ejected towards the cab.*
- ▲ *Never start or continue to work a machine if people are nearby or approaching - Stop and wait until they are at a safe distance before continuing. WARNING: Some cutting heads may continue to 'freewheel' for up to 40 seconds after being stopped.*
- ▲ *Never attempt to use a machine on materials in excess of its capability.*
- ▲ *Never use a machine to perform a task it has not been designed to do.*
- ▲ *Never operate the tractor or machine controls from any position other than from the driving seat, especially whilst hitching or unhitching the machine.*
- ▲ *Never carry out maintenance of a machine or a tractor whilst the engine is running – the engine should be switched off, the key removed and pocketed.*
- ▲ *Never leave a machine unattended in a raised position – it should be lowered to the ground in a safe position on a level firm site.*
- ▲ *Never leave a tractor with the key in or the engine running.*
- ▲ *Never carry out maintenance on any part or component of a machine that is raised unless that part or component has been properly substantially braced or supported.*
- ▲ *Never attempt to detect a hydraulic leak with your hand – use a piece of cardboard.*
- ▲ *Never allow children near to, or play on, a tractor or machine under any circumstances.*

ADDITIONAL SAFETY ADVICE

Training

Operators need to be competent and fully capable of operating this machine in a safe and efficient way prior to attempting to use it in any public place. We advise therefore that the prospective operator make use of relevant training courses available such as those run by the Agricultural Training Board, Agricultural Colleges, Dealers and McConnel.

Working in Public Places

When working in public places such as roadsides, consideration should be paid to others in the vicinity. Stop the machine immediately when pedestrians, cyclists and horse riders etc. pass. Restart only when they are at a distance that causes no risk to their safety.

Warning Signs

It is advisable that any working area be covered by suitable warning signs and statutory in public places. Signs should be highly visible and well placed in order to give clear advanced warning of the hazard. Contact the Department of Transport or your Local Highways Authority to obtain detailed information on this subject. The latter should be contacted prior to working on the public highway advising them of the time and location of the intended work asking what is required by way of signs and procedure. – *‘Non-authorized placement of road signs may create offences under the Highways Act’.*

Suggested Warning Signs Required

‘Road works ahead’ warning sign with a supplementary ‘Hedge cutting’ plate. ‘For 1 mile’ or appropriate shorter distance may be added to the plate.

‘Road narrows’ warning signs with supplementary ‘Single file traffic’ plate.

White on blue ‘Keep right’ () arrow sign on rear of machine.*

** Note – this applies to UK Market machines where traffic passes to the right of a machine working in the same direction as the traffic flow. The direction, use and colour of the arrow sign will depend on the country of use and the Local Highway Authorities regulations in the locality.*

Use of Warning Signs

- ▲ *On two-way roads one set of signs is needed facing traffic in each direction.*
- ▲ *Work should be within 1 mile of the signs.*
- ▲ *Work only when visibility is good and at times of low risk e.g.: NOT during ‘rush-hour’.*
- ▲ *Vehicles should have an amber-flashing beacon.*
- ▲ *Ideally, vehicles should be conspicuously coloured.*
- ▲ *Debris should be removed from the road and path as soon as practicable, and at regular intervals, wearing high visibility clothing and before removing the hazard warning signs.*
- ▲ *Collect all road signs promptly when the job is completed.*

Although the information stated here covers a wide range of safety subjects it is impossible to predict every eventuality that can occur under differing circumstances whilst operating this machine. No advice given here can replace ‘good common sense’ and ‘total awareness’ at all times, but will go a long way towards the safe use of your McConnel machine.

DECALS

The following decals will be displayed on the Sheartrim:

Safety Decal

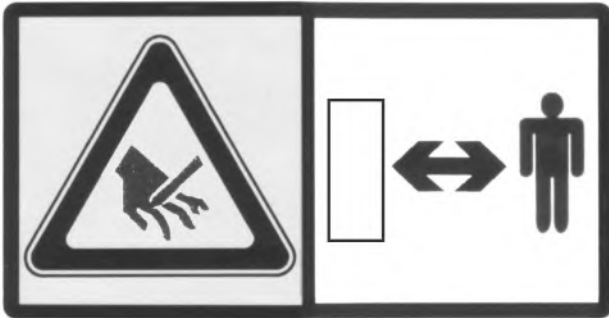

Generic Danger – do not approach when the cutting bar is working

Use and Maintenance Decals



Generic Danger – Read the manual first

Greasing Points

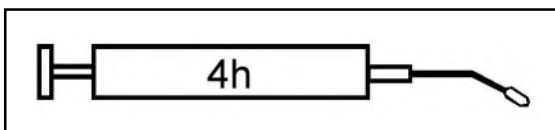

Grease periodically

These decals are displayed for reasons of safety and advice - it is important that they are readable at all times and should be replaced if they become damaged or unreadable.

VEHICLE / TRACTOR PREPARATION

We recommend vehicles are fitted with cabs using 'safety glass' windows and protective guarding when used with our machines.

Fit Operator Guard (Part No. 7313324) using the hooks provided. Shape the mesh to cover all vulnerable areas. The driver must be looking through mesh and/or polycarbonate glazing when viewing the flail head in any working position - unless the vehicle/ cab

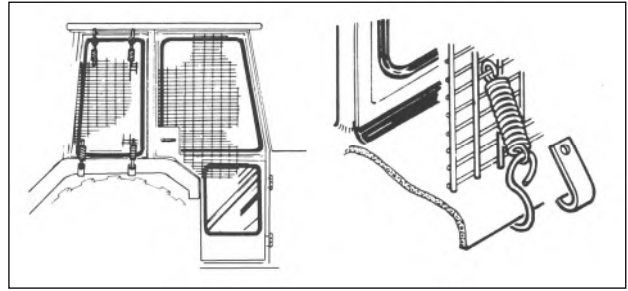

manufacturer can demonstrate that the penetration resistance is equivalent to, or higher than, that provided by mesh/polycarbonate glazing. If the tractor has a roll bar only, a frame must be made to carry both mesh and polycarbonate glazing. The operator should also use personal protective equipment to reduce the risk of serious injury such as; eye protection (mesh visor to EN1731 or safety glasses to EN166), hearing protection to EN352, safety helmet to EN297, gloves, filter mask and high visibility clothing.

Vehicle Ballast: It is imperative when attaching 'third-party' equipment to a vehicle that the maximum possible stability of the machine and vehicle combination is achieved – this can be accomplished by the utilisation of 'ballast' in order to counter-balance the additional equipment added.

Front weights may be required for rear mounted machines to place 15% of total outfit weight on the front axle for stable transport on the road and to reduce 'crabbing' due to the drag of the cutting unit when working on the ground.

Rear weights may be required to maintain a reasonable amount of rear axle load on the opposite wheel from the arms when in work; for normal off-ground work i.e. hedge cutting this should be 20% of rear axle weight or more for adequate control, and for ground work i.e. verge mowing with experienced operators, this can be reduced to 10%.

All factors must be addressed in order to match the type and nature of the equipment added to the circumstances under which it will be used – in the instance of Power Arm hedgecutters it must be remembered that the machines centre of gravity during work will be constantly moving and will differ from that during transport mode, therefore balance becomes critical.

Factors that effect stability:

- Centre of gravity of the tractor/machine combination.
- Geometric conditions, e.g. position of the cutting head and ballast.
- Weight, track width and wheelbase of the tractor.
- Acceleration, braking, turning and the relative position of the cutting head during these operations.
- Ground conditions, e.g. slope, grip, load capability of the soil/surface.
- Rigidity of implement mounting.

Suggestions to increase stability:

- Increasing rear wheel track; a vehicle with a wider wheel track is more stable.
- Ballasting the wheel; it is preferable to use external weights but liquid can be added to around 75% of the tyre volume – water with anti-freeze or the heavier Calcium Chloride alternative can be used.
- Addition of weights – care should be taken in selecting the location of the weights to ensure they are added to a position that offers the greatest advantage.
- Front axle locking (check with tractor manufacturer).

NOTE: The advice above is offered as a guide for stability only and is not a guide to vehicle strength. It is recommended that you consult your vehicle manufacturer or local dealer to obtain specific advice on this subject, additionally advice should be sought from a tyre specialist with regard to tyre pressures and ratings suitable for the type and nature of the machine you intend to fit.

PROCEDURE FOR USE

⚠ CAUTION Machine must only be used for mowing and cutting grass, hedges, reeds or wood plant material up to a maximum diameter of 25mm.

Handling

Handling of this machine, as with all machinery, should only be performed using suitable lifting equipment operated by persons fully trained in its safe use.

Hoisting

Before hoisting the Sheartrim ensure that the hoisting equipment is suitable for lifting the weight of the machine and that the working area has been inspected to detect the presence of possible dangers such as electric power lines, gas or fluid lines etc. Ensure that there is sufficient space and headroom for safe manoeuvring and all bystanders are kept at a safe distance at all times.

Anchor hoisting hooks at the lifting eyelet positions ensuring that the unit is balanced before attempting to raise the machine.

⚠ WARNING

Failure to follow the above instructions may result in injury to persons or damage to the machinery.

INSTALLATION

Before beginning installation ensure that the specifications of the 'vehicle' machine match those of the Sheartrim and that the connecting pipes are suitable to sustain the maximum working pressure. The working environment and all connections and fittings should be kept clean in order to protect the hydraulic system from contamination by grit or dirt.

Attaching

Fix the Sheartrim onto the 'vehicle' machine with the clamp plates and tighten the bolts to the correct torque setting – *refer to torque chart in the Maintenance Section.*

Hydraulic Connections

Attach the oil delivery hose to the hydraulic motor union (P) and the oil return hose to the hydraulic motor union (T). The system should be checked using a Manometer to ensure that the maximum pressures do not exceed the specified limits – *refer to specifications for the specific model.*

Blade Protection Guard

The blade protector must be removed prior to start up with the motor switched off and the oil not under pressure, and replaced only once the machine has stopped completely – *the protector should be in position at all times during transportation of the machine as a means of safeguard to people and machine.*

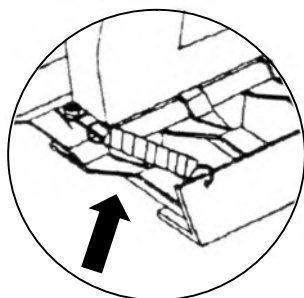

Protection Guard - Remove only with the motor switched off and the oil NOT under pressure.

HYDRAULIC MOTOR CONNECTIONS

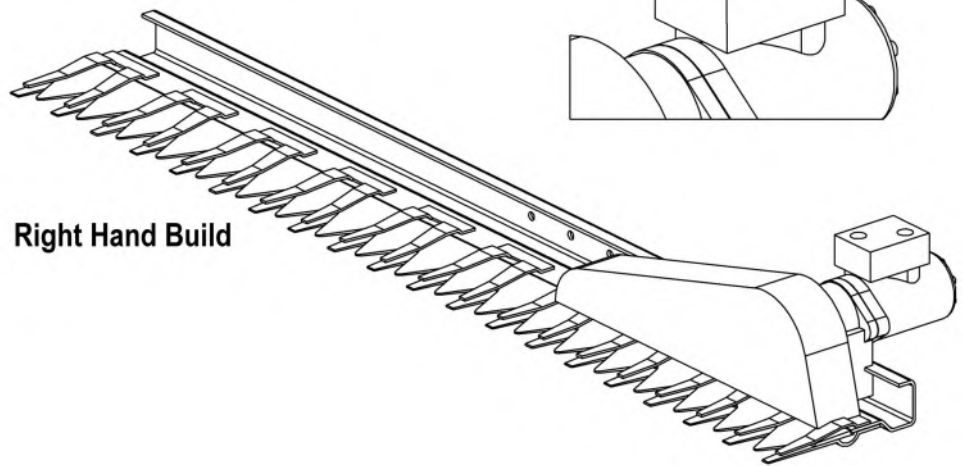
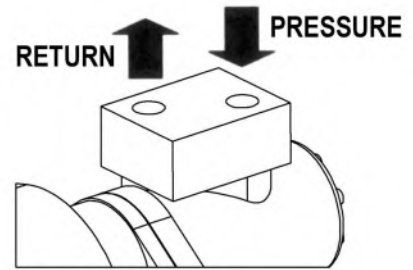
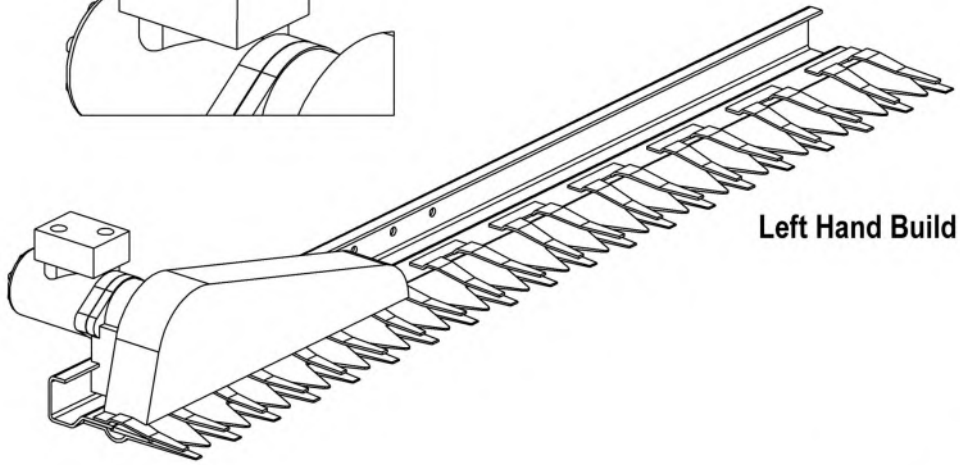
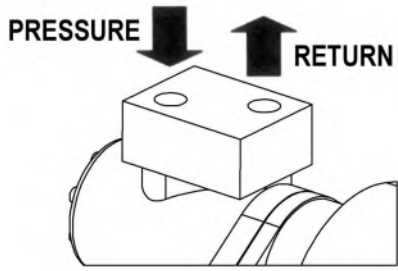

START UP AND OPERATION

Start up and operation of the Sheartrim must only be carried out by an operator who has been fully trained in the use of such machinery and is fully aware of the dangers and hazards surround the use of this type of machine.

Ensure all persons remain at a safe distance of at least 2 metres before starting the machine and at all times whilst it is running.

⚠ WARNING Never approach the cutterbar whilst it is running or working.

On initial start up of the machine keep the speed to a minimum for several minutes after which time the machine can then put through some light movement to check all functions operate correctly. It is not advisable to increase pressure beyond 100Bar therefore a max pressure valve is fitted on the motor – *it is advisable to install a Manometer between the pump and the motor and it is recommended that the motor is started with the valve completely loosened and the pressure gradually raised until the desired cutting effect obtained.*

On new machines the tightness of all nuts, connectors, pipes and clamps should be checked on an hourly basis during the first day of work, and where necessary retightened. On subsequent days work the same procedure should be carried out at regular intervals and always prior to starting work each day.

WORKING

This machine must only be operated by persons who are fully trained and familiar with machinery of this type. The work area should be thoroughly inspected prior to starting in order to detect and note possible dangers or hazards – removable objects that may cause problems such as wire, glass, bricks or large stones etc. should be cleared from the work area beforehand and any immovable hazards should be clearly marked in order to avoid them.

The Sheartrim must only be used for cutting materials for which it is designed – grass, hedges, shrubs and wood plant materials up to maximum of 25mm diameter – failure to observe this may cause injury to persons and/or damage to the machine.

The machine is capable of work immersed in water providing it is kept properly and regularly greased but care must be taken in these situations as possible hazards and dangers may be hidden from the view of the operator.

⚠ WARNING Keep all persons and animals at a safe distance from the machine whilst working – if passers-by approach work should be halted until they are clear of the danger area.

TRANSPORTATION OF THE MACHINE

Wherever possible for transportation the machine should be positioned within the width of the carrying vehicle with the blade protection guard fitted and machine controls positioned or protected against accidental or inadvertent operation during transport. Warning lights and/or signs should be displayed as and where required or if local highway authority rules dictate.

MACHINE REMOVAL

Turn off the motor and ensure that the hydraulic oil is not under pressure before removing the pipes connected to the cutting bar motor. Block and support the Sheartrim before finally loosening and removing the bolts that attach the unit to the 'vehicle' machine. Transport the unattached Sheartrim using suitable means and store on a level, safe, clean and dry environment where it will not cause hazard or danger to others.

Always grease the machine prior to storage and ensure blade protectors are fitted.

MAINTENANCE

⚠ WARNING Before any work is carried out on the machine the motor must be switched off and the hydraulic unit free of pressure. Remove the ignition key and secure the carrier vehicle against unintended operation or movement.

⚠ WARNING Always wear suitable protection such as gloves, safety glasses, safety boots etc. when carrying out maintenance or repair work on this machine.

General Maintenance

- Check nuts, bolts and fixings on a regular basis and retighten if necessary.
- Lubricate grease points before starting work and every 4 hours thereafter.
- Check condition of the hydraulic hoses on a regular basis - replace damaged or worn hydraulic hoses if required. Ensure replacement hoses conform to the manufacturer's specifications.

Torque Settings

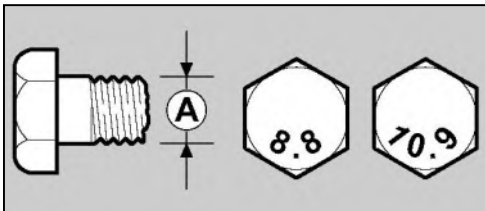

A = thread size (indicated on the head of the bolt)

A Ø	6.8	8.8	10.9	12.9
	Torque Setting (Nm)			
M4	2.2	3.0	4.4	5.1
M5	4.5	5.9	8.7	10
M6	7.6	10	15	18
M8	18	25	36	43
M10	37	49	72	84
M12	64	85	125	145
M12x1.5	--	92	132	155
M14x1.5	--	145	210	245
M14	100	135	200	235
M16	160	210	310	365
M16x1.5	--	230	340	390
M18	220	300	430	500
M20x1.5	--	480	680	1350
M20	310	425	610	710
M22	425	580	820	960
M24x2	--	810	1150	1350
M24	535	730	1050	1220
M30x2	--	1650	2300	2750

TROUBLESHOOTING

Problem	Possible Cause	Remedy
Upper blade not moving	<ul style="list-style-type: none">- Incorrect connection- Pump not switched on	<ul style="list-style-type: none">- Check connections- Retighten screw connections- Switch on pump (If necessary check circuit breaker on vehicle)
Shears do not change direction with pressure	<ul style="list-style-type: none">- Connections crossed- Pump pressure too low	<ul style="list-style-type: none">- Read operating manual outrigger- Consult specialist workshop
Shears running too fast	<ul style="list-style-type: none">- Oil quantity too large	<ul style="list-style-type: none">- Consult specialist workshop mounting oil-flow divider
Shears do not change direction	<ul style="list-style-type: none">- Incorrect setting end stops- Too much grease in guide holes	<ul style="list-style-type: none">- Consult specialist workshop- Remove excess grease
Small twigs and branches are not cut smoothly and cleanly	<ul style="list-style-type: none">- Cutters worn	<ul style="list-style-type: none">- Grind cutter bars



For best performance ...

USE ONLY GENUINE McCONNEL SERVICE PARTS

*To be assured of the latest design improvements purchase your
'Genuine Replacements' from the 'Original Equipment Manufacturer'*

McCONNEL LIMITED

Through your local Dealer or Stockist

Always quote:

- ***Machine Type***
- ***Serial Number***
- ***Part Number***

*Design improvements may alter some of the parts listed in this manual –
the latest part will always be supplied when it is interchangeable with an earlier one.*

1.5M CUTTERBAR ASSEMBLY

McCONNEL

Module(s): 42018.01 – L/H Build, 42018.05 – R/H Build

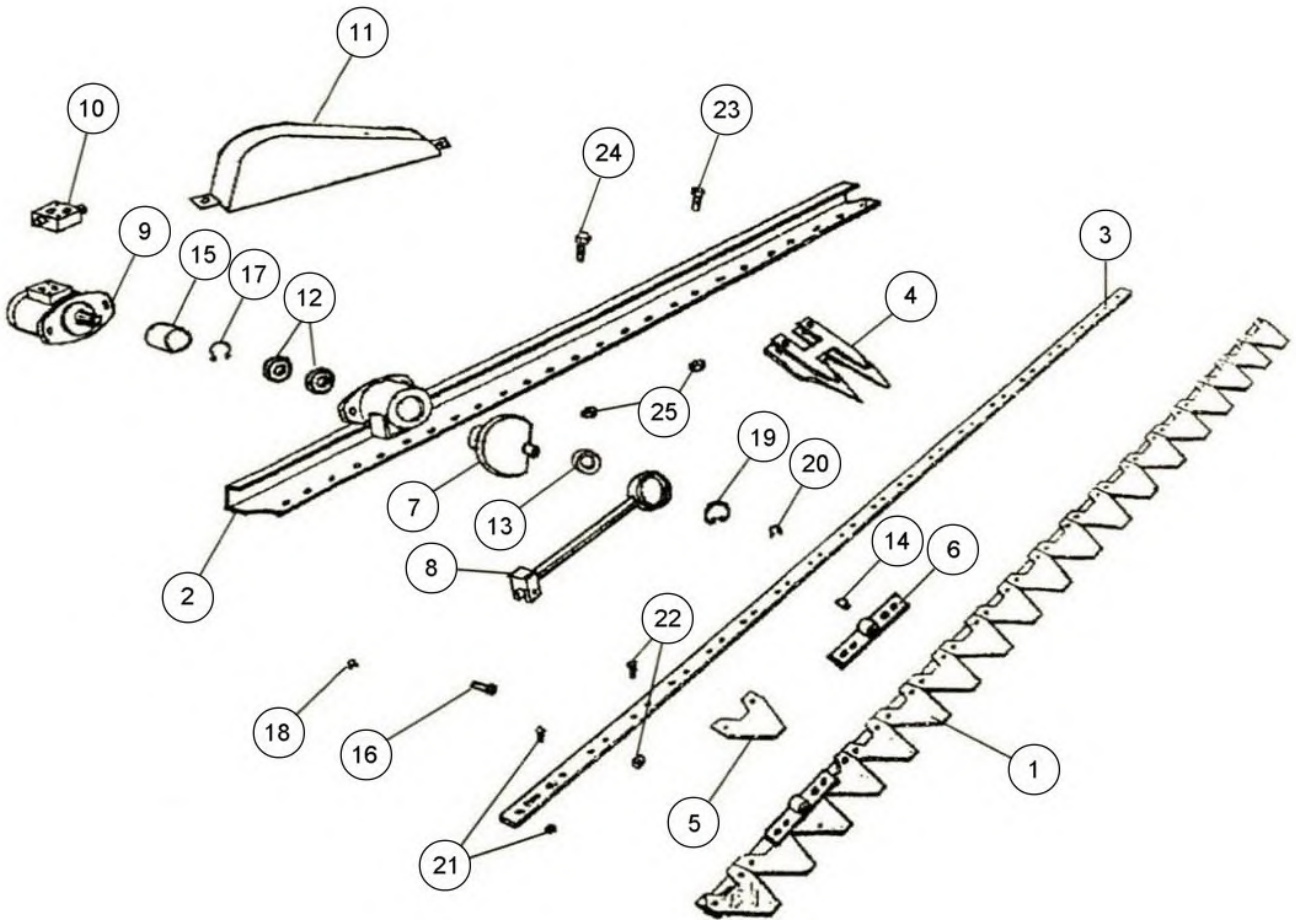

1.5M CUTTERBAR ASSEMBLY**McCONNEL**

Module(s): 42018.01 – L/H Build, 42018.05 – R/H Build

REF.	QTY.	PART NO.	DESCRIPTION
		42018.01	1.5M CUTTERBAR ASSEMBLY - L/H Build
		42018.05	1.5M CUTTERBAR ASSEMBLY - R/H Build
1	1	42018.34	CUTTER BAR
2	1	42018.14	BLADE 1480 - L/H Build
	1	42018.29	BLADE 1480 - R/H Build
3	1	42018.28	BACKING BAR
4	10	42018.26	FINGER
5	19	42018.27	KNIFE
6	1	42018.32	BRACKET
7	1	42018.16	FLYWHEEL
8	1	42018.18	CONROD
9	1	42018.10	MOTOR
10	1	42018.35	DISTRIBUTION BLOCK
11	1	42018.36	GUARD
12	2	42018.13	BEARING
13	1	42018.17	BEARING
14	1	42018.33	BUSH
15	1	42018.11	SPACER
16	1	42018.19	PIN
17	1	42018.12	CIRCLIP
18	1	42018.20	CIRCLIP
19	1	42018.21	CIRCLIP
20	1	42018.22	CIRCLIP
21	35	42018.30	NUT & BOLT ASSEMBLY
22	4	42018.31	NUT & BOLT ASSEMBLY
23	20	05.264.13	SETSCREW
24	2	05.264.15	SETSCREW
25	20	42018.25	NUT

1.5M STANDARD DUTY SHEARTRIM CUTTERBAR

McCONNEL

Module(s): 7490821

Application: Swingtrim (L/H working)

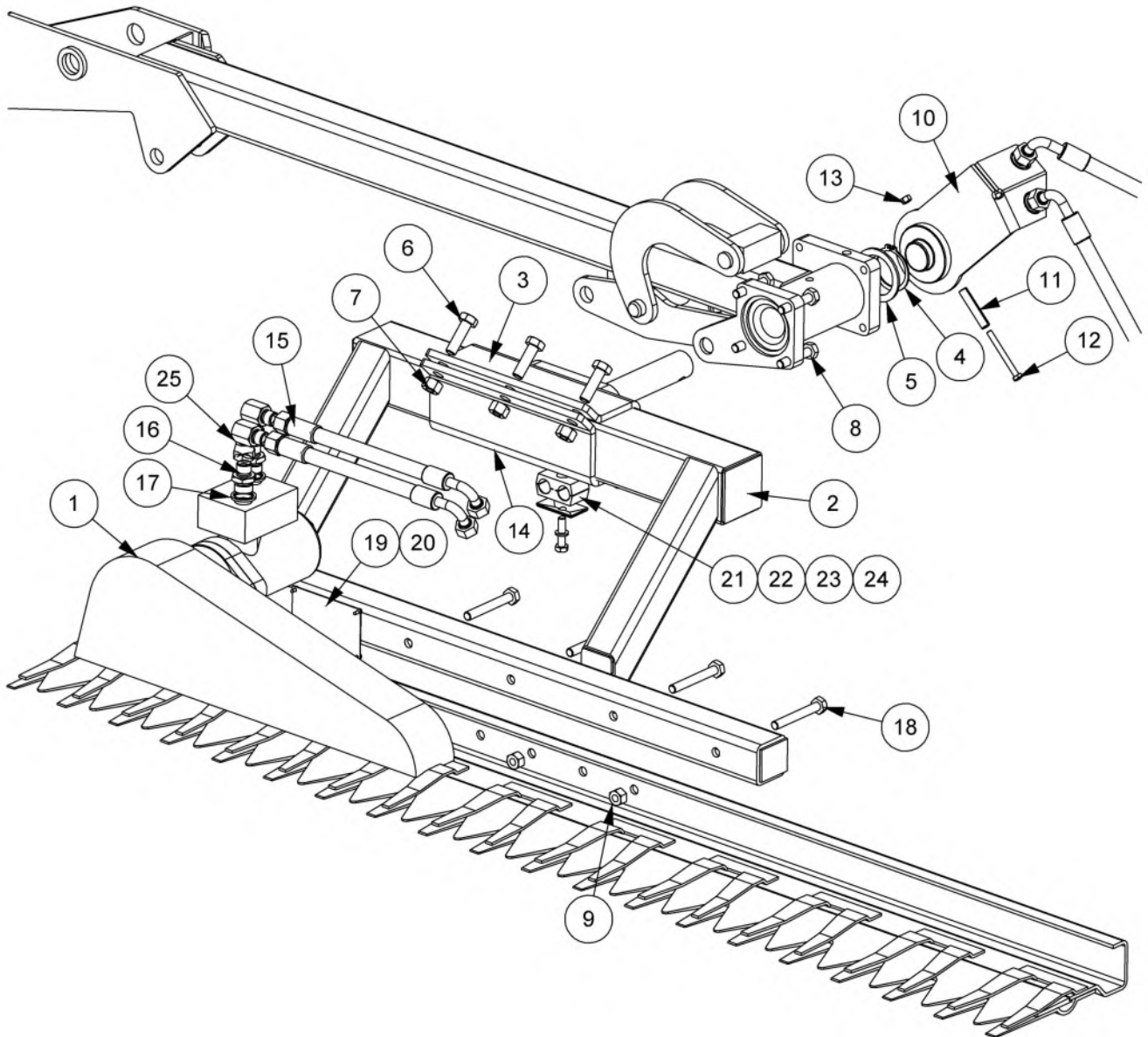

1.5M STANDARD DUTY SHEARTRIM CUTTERBAR

McCONNEL

Module(s): 7490821

REF.	QTY.	PART No.	DESCRIPTION
		7490821	1.5M SHEARTRIM (STD. DUTY) L/H Build
1	1	42018.01	CUTTER BAR - L/H Build
2	1	42019.09	CUTTER BAR BRACKET - L/H Build
3	1	21943.01	BRACKET
4	1	0406247	EXTERNAL CIRCLIP
5	1	1090037	RETAINING WASHER
6	5	9213086	BOLT
7	5	9143006	SELF-LOCKING NUT
8	4	9213105	BOLT
9	8	9143005	SELF-LOCKING NUT
10	1	41297.04	HOSE BRACKET
11	1	0428150	SPRING DOWEL
12	1	9213123	BOLT
13	1	9143003	SELF-LOCKING NUT
14	1	21873.01	CLAMP PLATE
15	2	10.004.18	HOSE - 3/8" BSP FS/F90 x 900mm
16	2	6000112	ADAPTOR
17	2	8650104	BONDED SEAL
18	4	9213155	BOLT
19	1	41.094.07	SERIAL No. PLATE
20	4	7103230	POP RIVET
21	1	42024.09	TWIN CLAMP
22	1	7193066	CLAMP PLATE
23	1	9100204	SPRING WASHER
24	1	9213074	BOLT
25	2	8581117	ADAPTOR ELBOW

1.5M STANDARD DUTY SHEARTRIM CUTTERBAR

McCONNEL

Module(s): 7490963

REF.	QTY.	PART No.	DESCRIPTION
		7490963	1.5M SHEARTRIM (STD. DUTY) R/H Build
1	1	42018.05	CUTTER BAR - R/H Build
2	1	42019.10	CUTTER BAR BRACKET - R/H Build
3	1	21943.01	BRACKET
4	1	0406247	EXTERNAL CIRCLIP
5	1	1090037	RETAINING WASHER
6	5	9213086	BOLT
7	5	9143006	SELF-LOCKING NUT
8	4	9213105	BOLT
9	8	9143005	SELF-LOCKING NUT
10	1	41297.04	HOSE BRACKET
11	1	0428150	SPRING DOWEL
12	1	9213123	BOLT
13	1	9143003	SELF-LOCKING NUT
14	1	21873.01	CLAMP PLATE
15	2	10.004.18	HOSE - 3/8" BSP FS/F90 x 900mm
16	2	6000112	ADAPTOR
17	2	8650104	BONDED SEAL
18	4	9213155	BOLT
19	1	41.094.07	SERIAL No. PLATE
20	4	7103230	POP RIVET
21	1	42024.09	TWIN CLAMP
22	1	7193066	CLAMP PLATE
23	1	9100204	SPRING WASHER
24	1	9213074	BOLT
25	2	8581117	ADAPTOR ELBOW

1.5M STANDARD DUTY SHEARTRIM CUTTERBAR

McCONNEL

Module(s): 7490828

Application: PA31 (L/H Build)

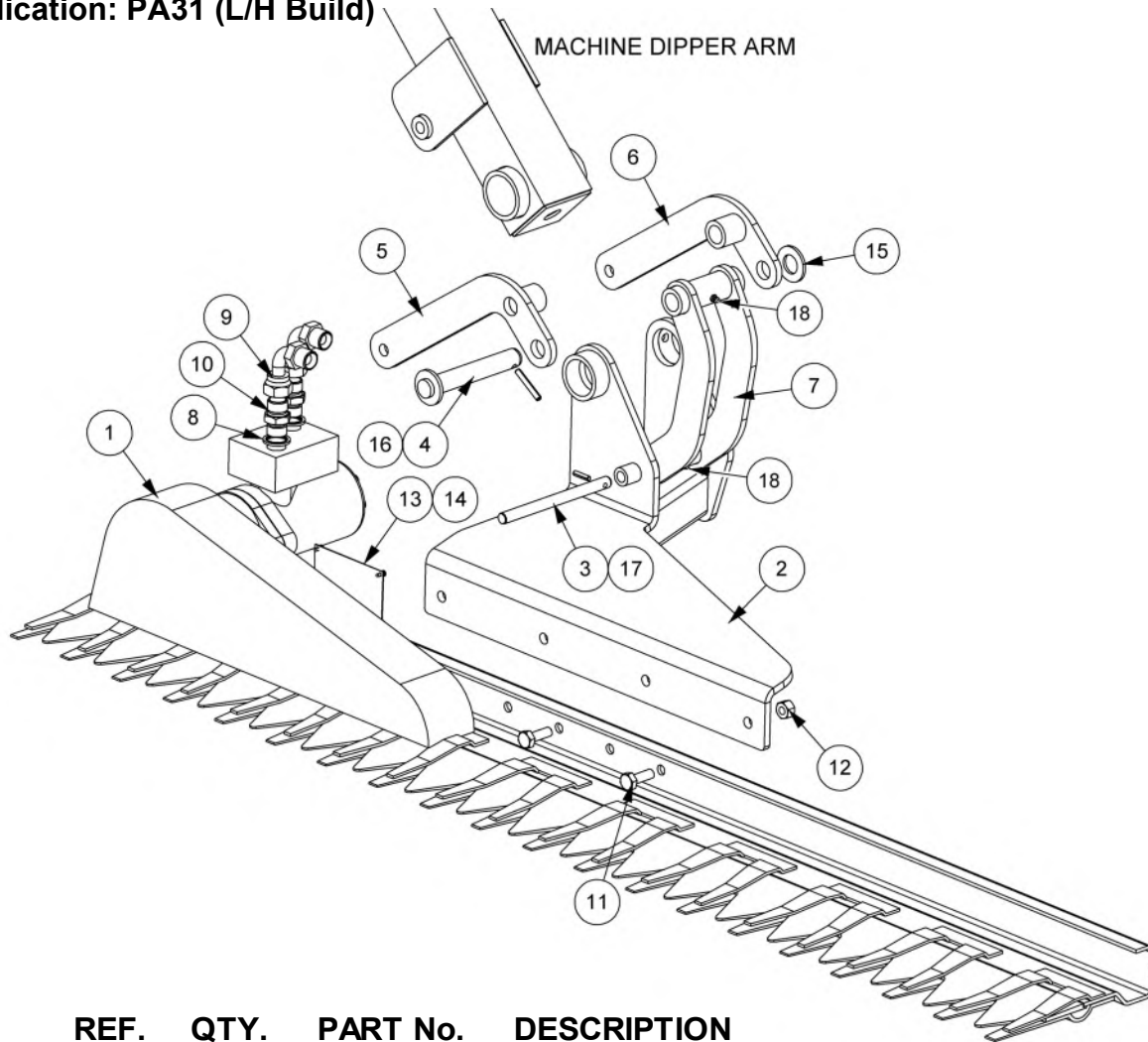

REF.	QTY.	PART No.	DESCRIPTION
		7490828	1.5M SHEARTRIM (STD. DUTY) L/H Build
1	1	42018.01	CUTTER BAR - L/H Build
2	1	22428.01	CUTTER BAR BRACKET - L/H Build
3	1	178.088	PIN
4	1	178.017	RAM PIN
5	1	178.089L	SLAVE LINK ARM
6	1	178.089R	SLAVE LINK ARM
7	1	178.091	LINK ASSEMBLY
8	2	8650104	BONDED SEAL
9	2	8581215	90° SWEEP ADAPTOR
10	2	8581110	ADAPTOR
11	4	9213065	BOLT
12	4	9143005	SELF-LOCKING NUT
13	1	41.094.07	SERIAL No. PLATE
14	4	7103230	POP RIVET
15	1	9100108	FLAT WASHER
16	1	0425640	SPRING DOWEL
17	1	0425522	SPRING DOWEL
18	2	0901161	GREASE NIPPLE
19	1	T8066	HOSE SLEEVING (<i>not shown</i>)
20	1	T3260	PLUG

1.5M STANDARD DUTY SHEARTRIM CUTTERBAR

McCONNEL

Module(s): 7490838

Application: PA31 (R/H Build)

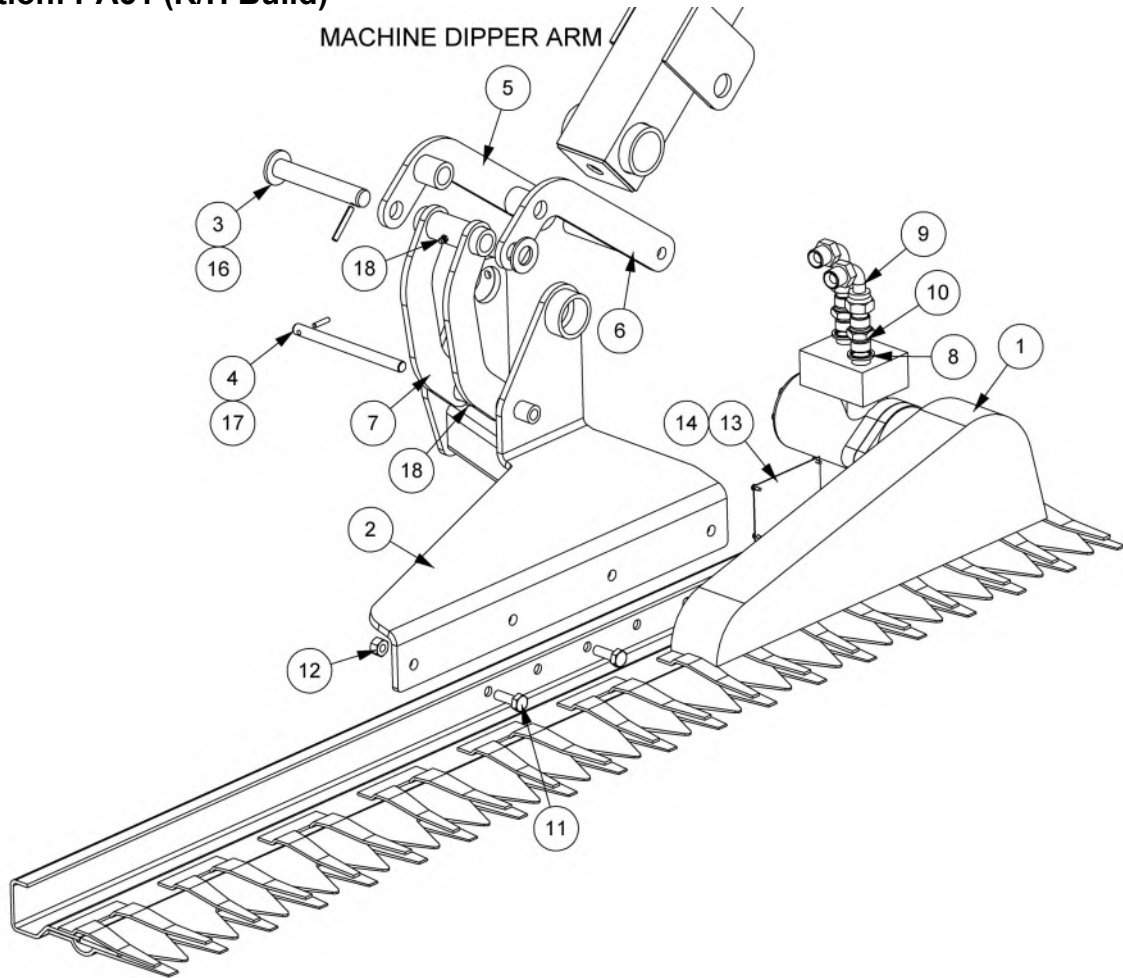

REF.	QTY.	PART No.	DESCRIPTION
		7490838	1.5M SHEARTRIM (STD. DUTY) R/H Build
1	1	42018.05	CUTTER BAR - R/H Build
2	1	22428.02	CUTTER BAR BRACKET - R/H Build
3	1	178.017	RAM PIN
4	1	178.088	PIN
5	1	178.089L	SLAVE LINK ARM
6	1	178.089R	SLAVE LINK ARM
7	1	178.091	LINK ASSEMBLY
8	2	8650104	BONDED SEAL
9	2	8581215	90° SWEEP ADAPTOR
10	2	8581110	ADAPTOR
11	4	9213065	BOLT
12	4	9143005	SELF-LOCKING NUT
13	1	41.094.07	SERIAL No. PLATE
14	4	7103230	POP RIVET
15	1	9100108	FLAT WASHER
16	1	0425640	SPRING DOWEL
17	1	0425522	SPRING DOWEL
18	2	0901161	GREASE NIPPLE
19	1	T8066	HOSE SLEEVING (not shown)
20	1	T3260	PLUG

1.5M STANDARD DUTY SHEARTRIM CUTTERBAR

McCONNEL

Module(s): 7490967

Application: PA32, PA35, PA41, MAG310 (L/H Builds)

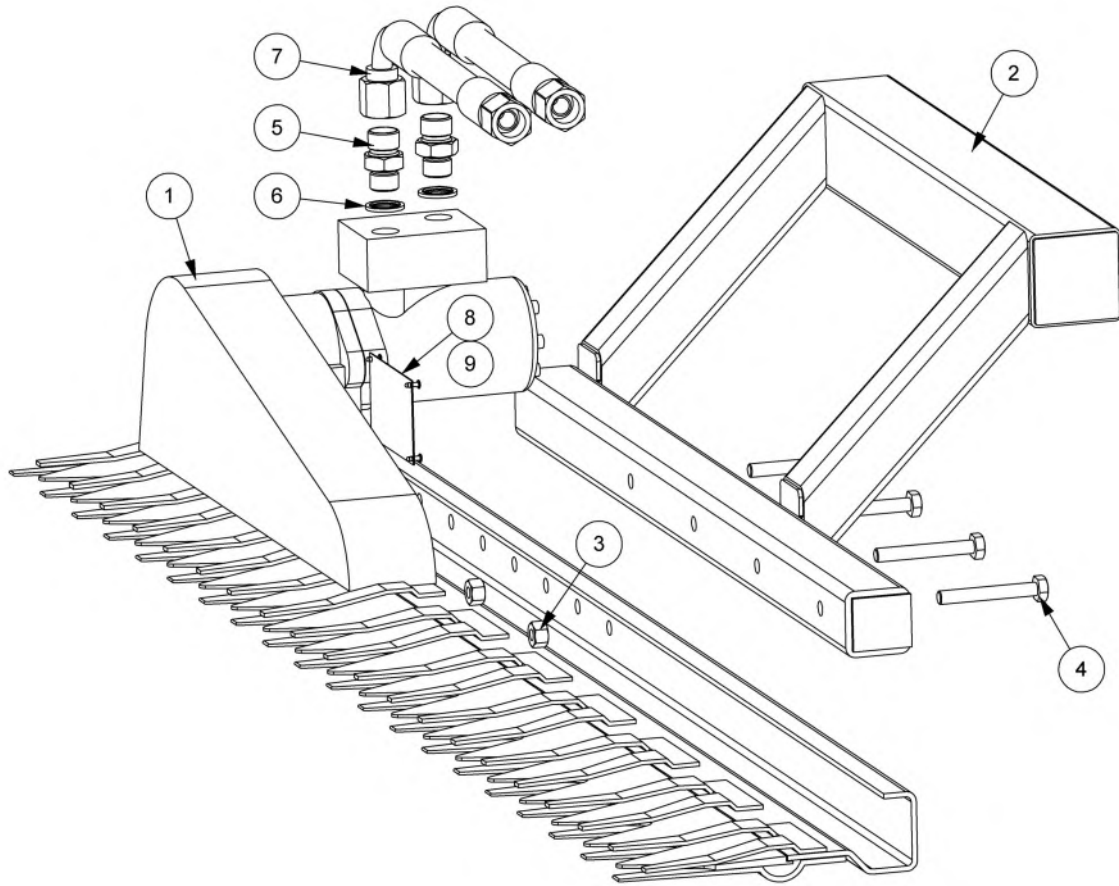

REF.	QTY.	PART No.	DESCRIPTION
		7490967	1.5M SHEARTRIM (STD. DUTY) L/H Build
1	1	42018.01	CUTTER BAR - L/H
2	1	42019.09	CUTTER BAR BRACKET - L/H
3	4	9143005	SELF-LOCKING NUT
4	4	9213155	BOLT
5	2	G3812120	ADAPTOR
6	2	8650104	BONDED SEAL
7	2	10.008.22	HOSE - 5/8" BSP FS/F90 x 1200mm
8	1	41.094.07	SERIAL No. PLATE
9	4	7103230	POP RIVET

1.5M STANDARD DUTY SHEARTRIM CUTTERBAR

McCONNEL

Module(s): 7490964

Application: PA32, PA35, PA41, MAG310 (R/H Builds)

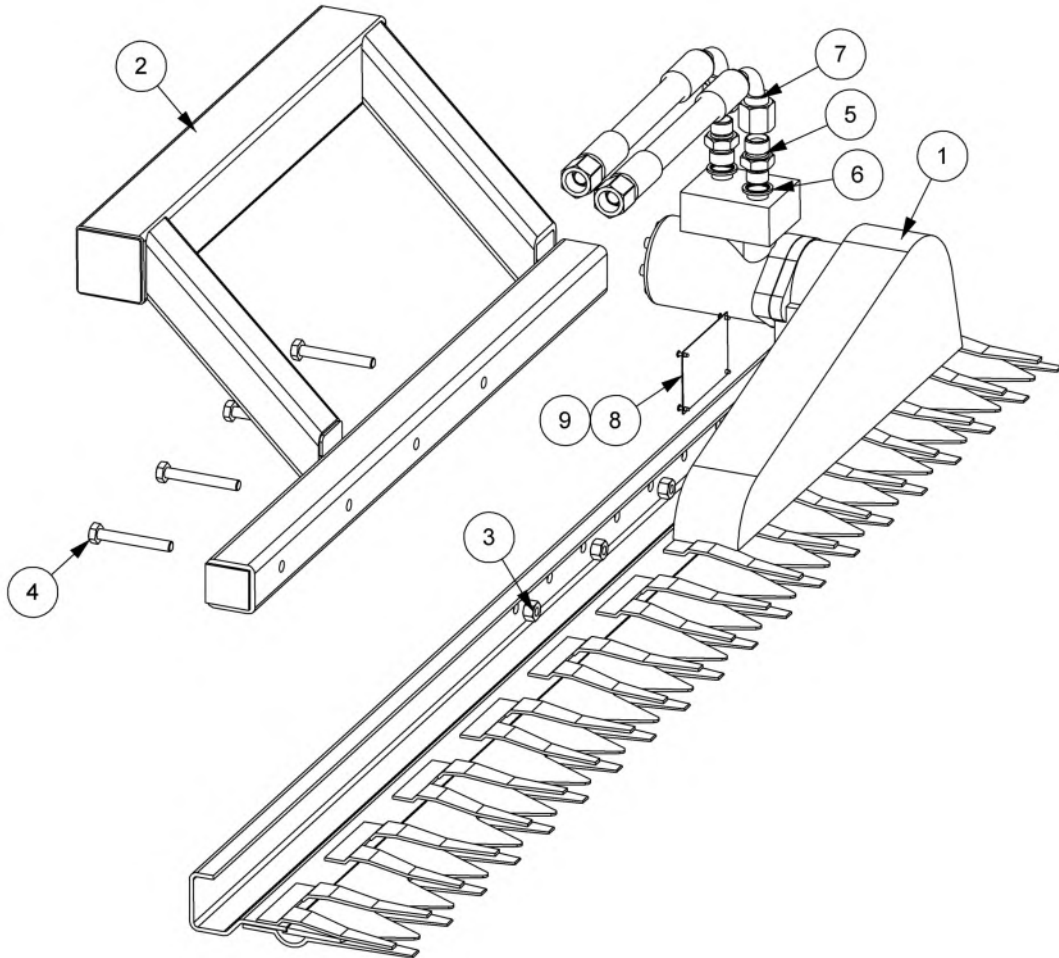

REF.	QTY.	PART No.	DESCRIPTION
		7490964	1.5M SHEARTRIM (STD. DUTY) R/H Build
1	1	42018.05	CUTTER BAR - R/H Build
2	1	42019.10	CUTTER BAR BRACKET - R/H Build
3	4	9143005	SELF-LOCKING NUT
4	4	9213155	BOLT
5	2	G3812120	ADAPTOR
6	2	8650104	BONDED SEAL
7	2	10.008.22	HOSE - 5/8" BSP FS/F90 x 1200mm
8	1	41.094.07	SERIAL No. PLATE
9	4	7103230	POP RIVET

1.5M STANDARD DUTY SHEARTRIM CUTTERBAR

McCONNEL

Module(s): 7490844

Application: PA47, MAG390, MAG450, MAG460 (L/H Builds)

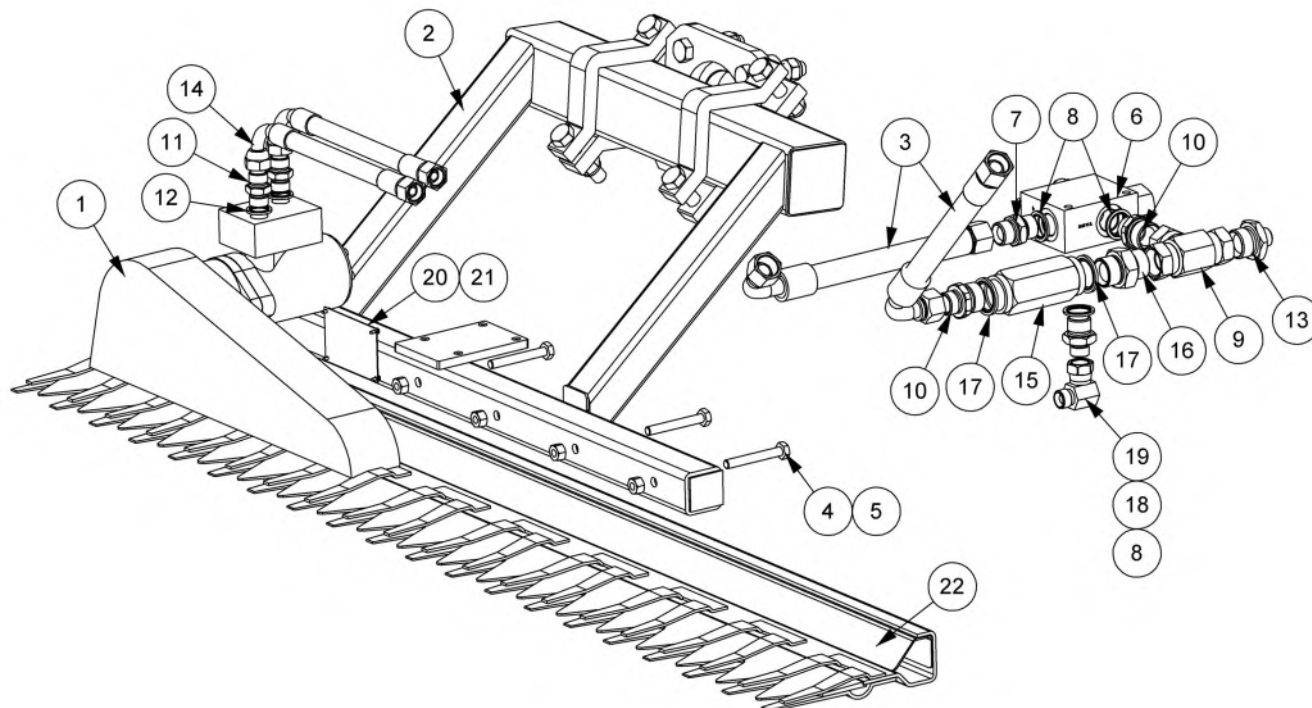

REF.	QTY.	PART No.	DESCRIPTION
		7490844	1.5M SHEARTRIM (STD. DUTY) L/H Build
1	1	42018.01	CUTTER BAR - L/H Build
2	1	42019.11	CUTTERBAR BRACKET - L/H Build
3	2	10.010.20	HOSE - 3/4" BSP FS/F90 x 1000mm
4	4	9213155	BOLT
5	4	9143005	SELF-LOCKING NUT
6	1	42844.01	FLOW CONTROL VALVE
7	1	8581136	ADAPTOR
8	3	8650106	BONDED SEAL
9	1	T7560	ADAPTOR TEE
10	2	8002086	ADAPTOR
11	2	8581110	ADAPTOR
12	2	8650104	BONDED SEAL
13	1	8581129	ADAPTOR
14	2	10.006.10	HOSE - 1/2" BSP FS/F90 x 500mm
15	1	06.282.03	CHECK VALVE
16	1	05.434.01	ADAPTOR
17	2	8650108	BONDED SEAL
18	1	8581130	ADAPTOR
19	1	G5200331	ADAPTOR ELBOW
20	1	41.094.07	SERIAL No. PLATE
21	4	7103230	POP RIVET
22	1	22662.01	SHIELD

1.5M STANDARD DUTY SHEARTRIM CUTTERBAR

McCONNEL

Module(s): 7490845

Application: PA47, MAG390, MAG450, MAG460 (R/H Builds)

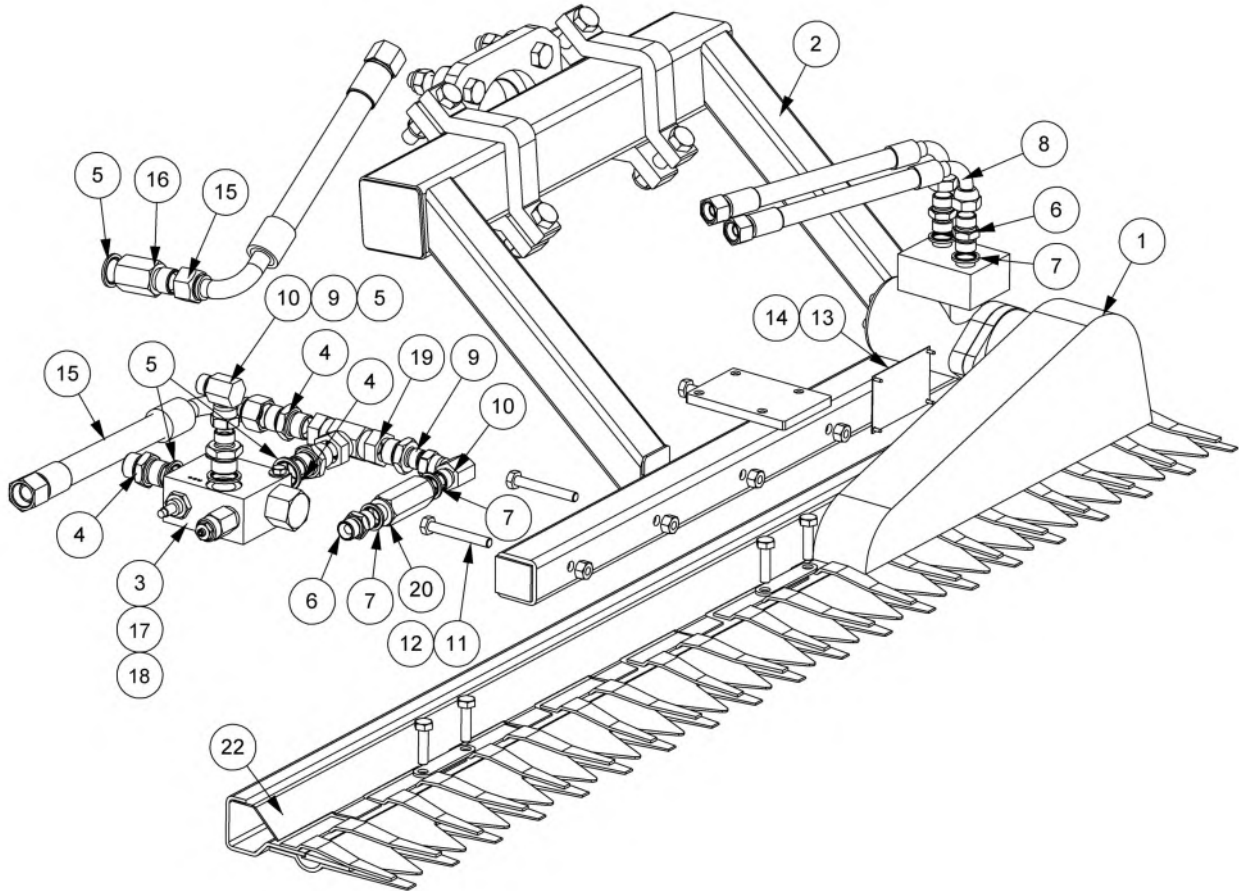

REF.	QTY.	PART No.	DESCRIPTION
		7490845	1.5M SHEARTRIM (STD. DUTY) R/H Build
1	1	42018.05	CUTTER BAR - R/H Build
2	1	42019.12	CUTTERBAR BRACKET - R/H Build
3	1	42844.01	FLOW CONTROL VALVE
4	3	8581136	ADAPTOR
5	4	8650106	BONDED SEAL
6	3	8581110	ADAPTOR
7	4	8650104	BONDED SEAL
8	2	10.006.10	HOSE - 1/2" BSP FS/F90 x 500mm
9	2	8581130	ADAPTOR
10	2	G5200331	ADAPTOR ELBOW
11	4	9213155	BOLT
12	4	9143005	SELF-LOCKING NUT
13	1	41.094.07	SERIAL No. PLATE
14	4	7103230	POP RIVET
15	2	10.010.20	HOSE - 3/4" BSP FS/F90 x 1000mm
16	1	8581224	EXTENSION ADAPTER
17	2	9213124	BOLT
18	2	9100104	FLAT WASHER
19	1	04.056.09	ADAPTOR TEE
20	1	8130694	CHECK VALVE
21	4	9213085	BOLT
22	1	42019.54	CUTTER BAR COVER ASSEMBLY

1.5M STANDARD DUTY SHEARTRIM CUTTERBAR

Module(s): 7490846

McCONEL

Application: PA48, PA50, PA52FM, MAG480, MAG520 (L/H Builds)

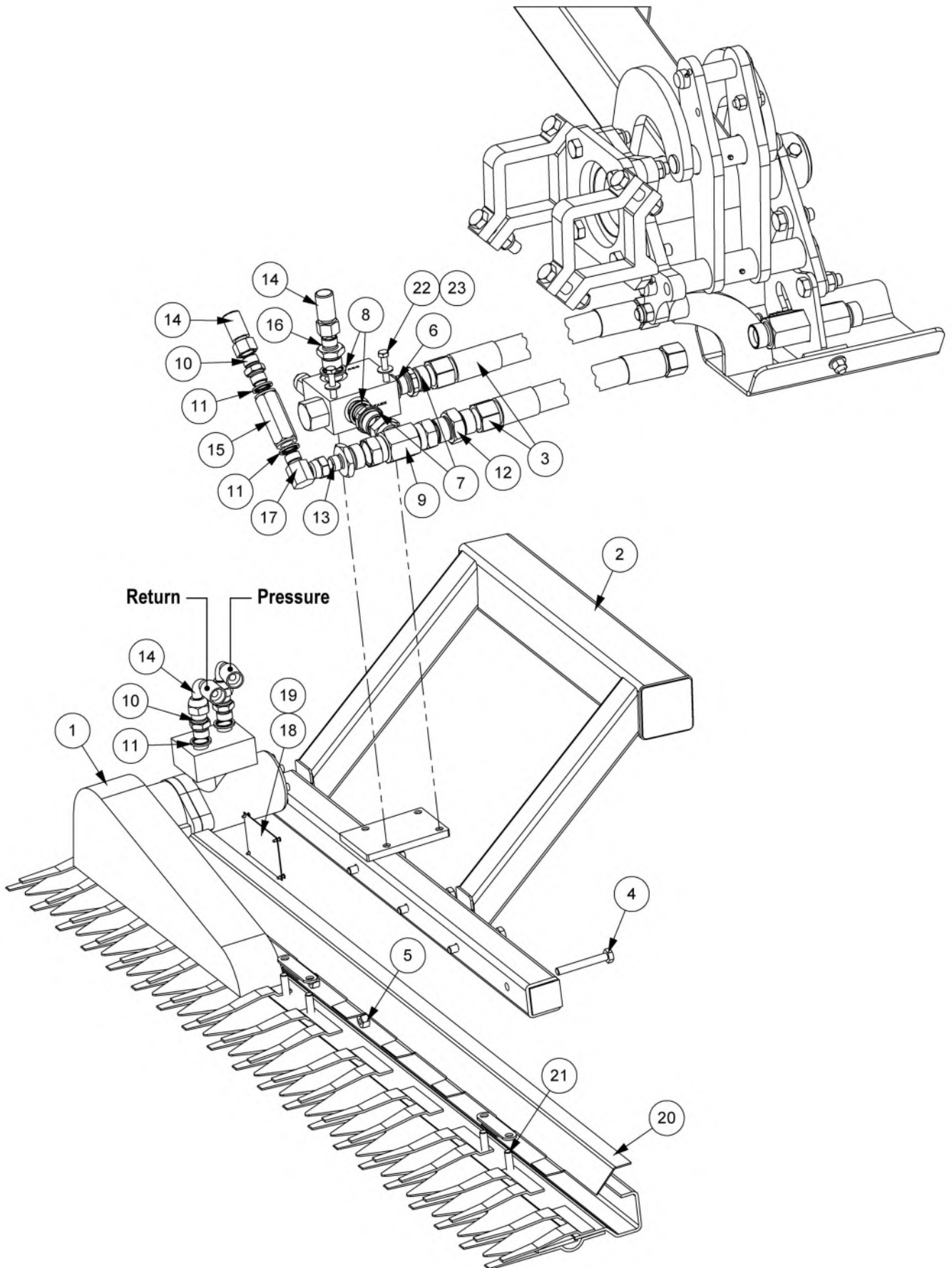

1.5M STANDARD DUTY SHEARTRIM CUTTERBAR

McCONNEL

Module(s): 7490846

REF.	QTY.	PART No.	DESCRIPTION
		7490846	1.5M SHEARTRIM (STD. DUTY) L/H Build
1	1	42018.01	CUTTER BAR - L/H Build
2	1	42019.11	CUTTERBAR BRACKET
3	2	10.011.09	HOSE - 1" BSP FS/FS x 450mm
4	4	9213155	BOLT
5	4	9143005	SELF-LOCKING NUT
6	1	42844.01	FLOW CONTROL VALVE
7	2	8002086	ADAPTOR
8	3	8650106	BONDED SEAL
9	1	T7560	ADAPTOR TEE
10	3	8581110	ADAPTOR
11	4	8650104	BONDED SEAL
12	1	05.434.01	ADAPTOR
13	1	8581129	ADAPTOR
14	2	10.006.04	HOSE - 1/2" BSP FS/F90 x 200mm
15	1	8130694	CHECK VALVE (2.0 BAR)
16	1	8581130	ADAPTOR
17	1	G5200331	ADAPTOR ELBOW
18	1	41.094.07	SERIAL No. PLATE
19	4	7103230	POP RIVET
20	1	42019.53	CUTTER BAR COVER
21	4	9213085	BOLT
22	2	9213124	BOLT
23	2	9100104	FLAT WASHER

1.5M STANDARD DUTY SHEARTRIM CUTTERBAR

Module(s): 7490847

McCONEL

Application: PA48, PA50, PA52FM, MAG480, MAG520 (R/H Builds)

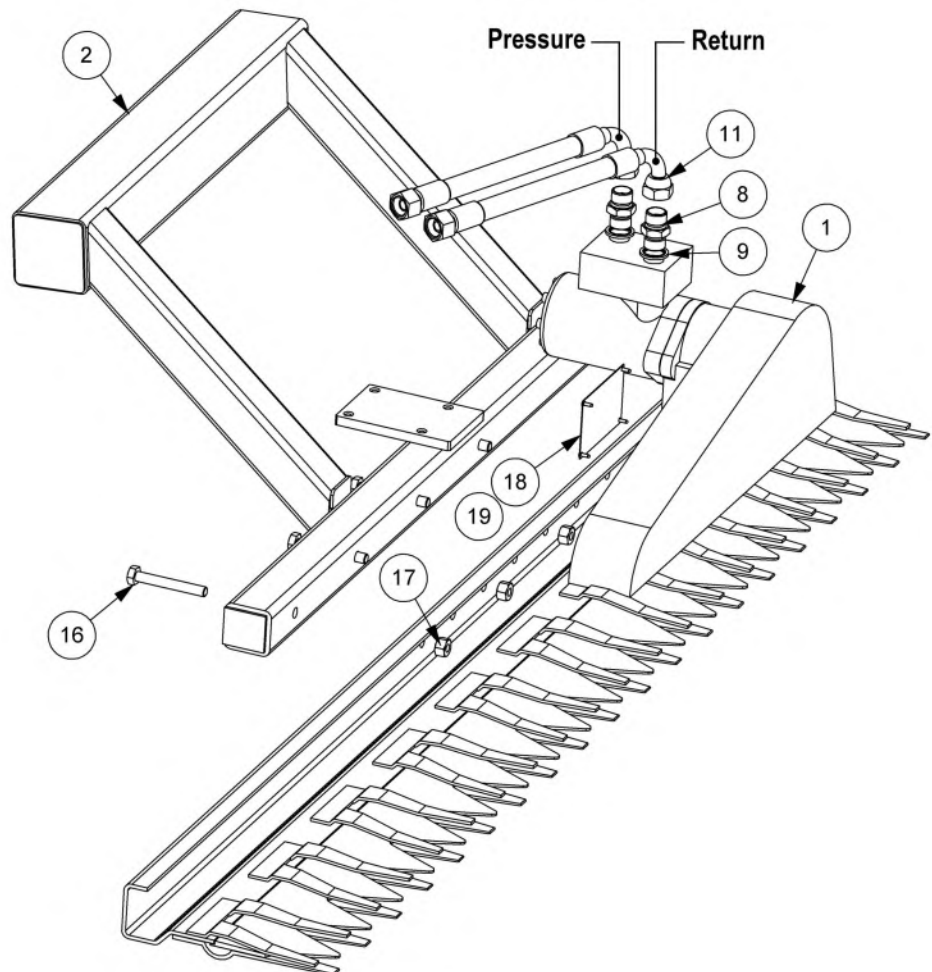
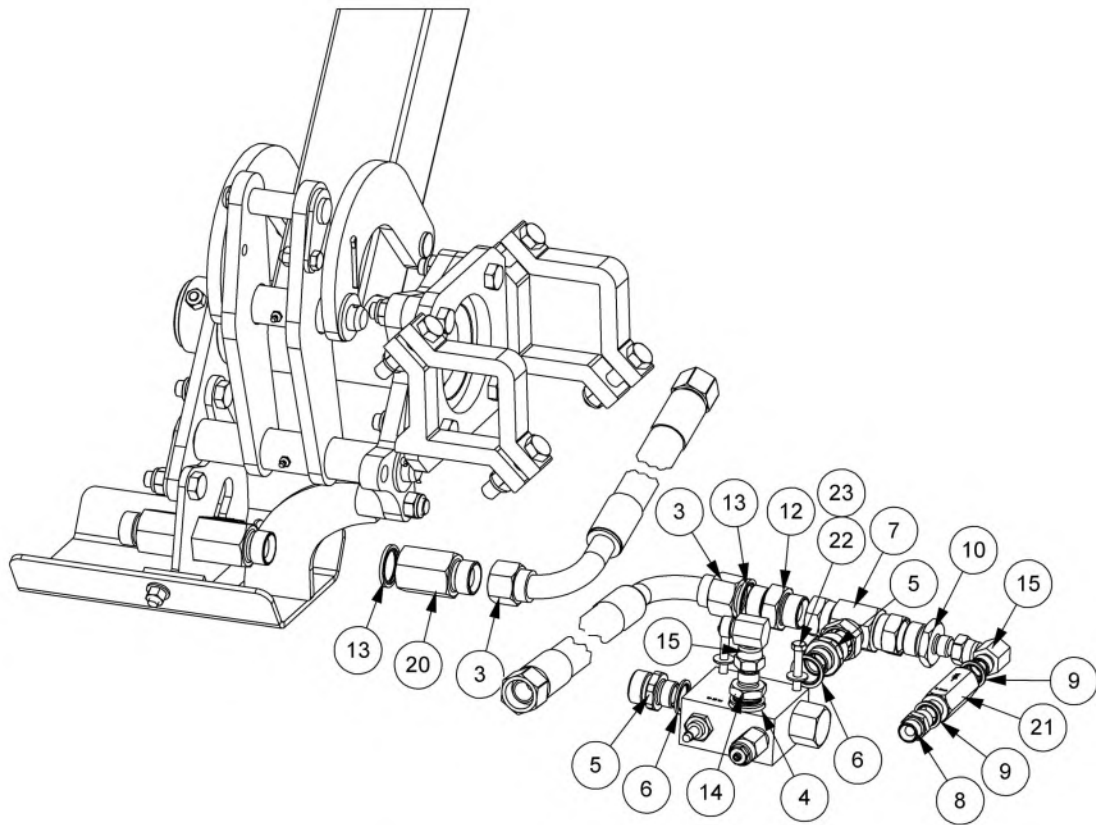

1.5M STANDARD DUTY SHEARTRIM CUTTERBAR

McCONNEL

Module(s): 7490847

REF.	QTY.	PART No.	DESCRIPTION
		7490847	1.5M SHEARTRIM (STD. DUTY) R/H Build
1	1	42018.05	CUTTER BAR - R/H Build
2	1	42019.12	CUTTERBAR BRACKET
3	2	10.012.20	HOSE - 1" BSP FS/F90 x 1000mm
4	1	42844.01	FLOW CONTROL VALVE
5	2	8002086	ADAPTOR
6	3	8650106	BONDED SEAL
7	1	T7560	ADAPTOR TEE
8	3	8581110	ADAPTOR
9	4	8650104	BONDED SEAL
10	1	8581129	ADAPTOR
11	2	10.006.10	HOSE - 1/2" BSP FS/F90 x 500mm
12	1	05.434.01	ADAPTOR
13	2	8650108	BONDED SEAL
14	1	8581130	ADAPTOR
15	2	G5200331	ADAPTOR ELBOW
16	4	9213155	BOLT
17	4	9143005	SELF-LOCKING NUT
18	1	41.094.07	SERIAL No. PLATE
19	4	7103230	POP RIVET
20	1	8581211	EXTENSION ADAPTOR
21	1	8130694	CHECK VALVE (2.0 BAR)
22	2	9213124	BOLT
23	2	9100104	FLAT WASHER

1.5M STANDARD DUTY SHEARTRIM CUTTERBAR

McCONNEL

Module(s): 7490848

Application: AG46, AG50, AG50+, MAG420, MAG450S (R/H Builds)

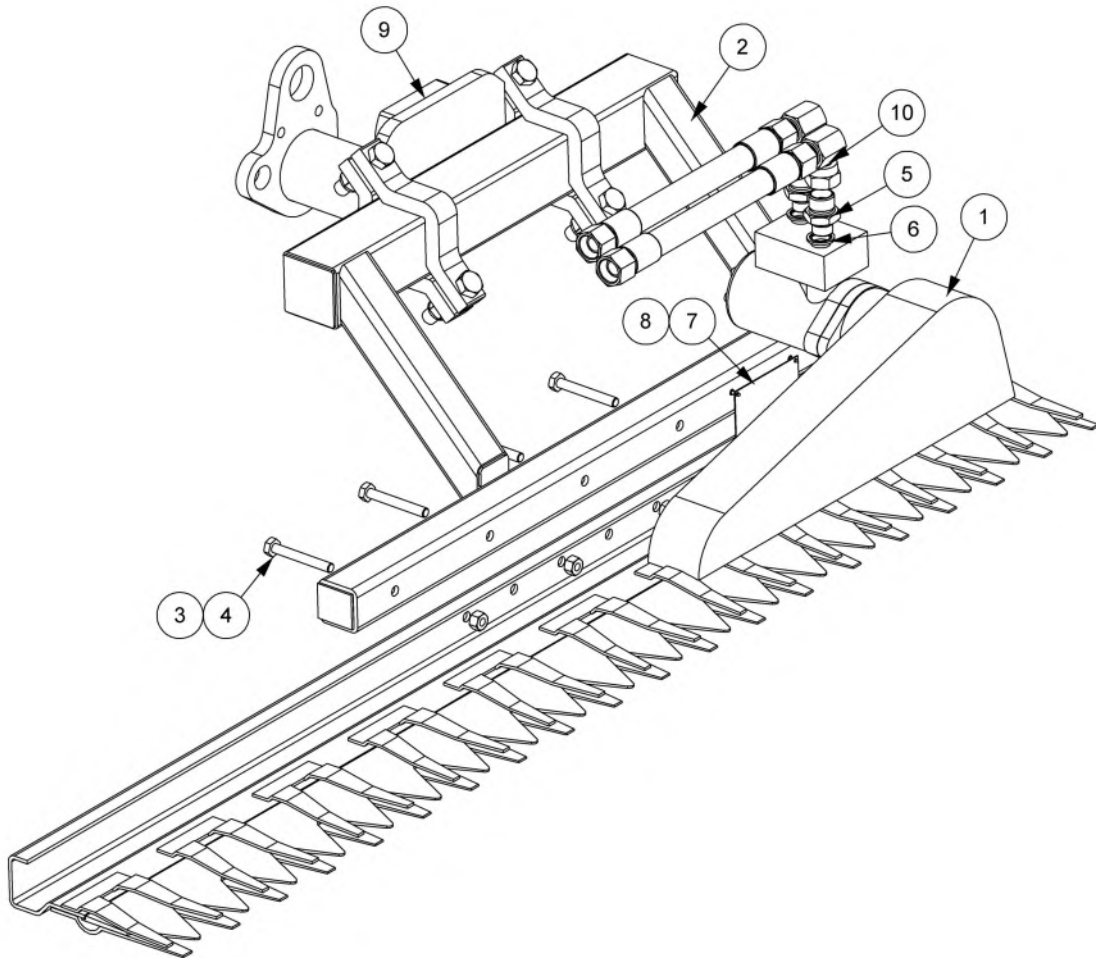

REF.	QTY.	PART No.	DESCRIPTION
		7490848	1.5M SHEARTRIM (STD. DUTY) R/H Build
1	1	42018.05	CUTTER BAR - R/H Build
2	1	42019.10	CUTTER BAR BRACKET - R/H Build
3	4	9143005	SELF-LOCKING NUT
4	4	9213155	BOLT
5	2	8581130	ADAPTOR
6	2	8650104	BONDED SEAL
7	1	41.094.07	SERIAL No. PLATE
8	4	7103230	POP RIVET
9	1	7198420	CLAMP KIT
10	2	05.835.03	ADAPTOR ELBOW



McConnel Limited, Temeside Works, Ludlow, Shropshire SY8 1JL. England.
Telephone: 01584 873131. Facsimile: 01584 876463. www.mcconnel.com