

Publication 313
May 2003
Part No. 41486.37
Revision: 21.02.08



ROTARY DITCHER & DITCH CLEANER Mk II

Operation & Parts Manual



McCONEl

IMPORTANT

VERIFICATION OF WARRANTY REGISTRATION



DEALER WARRANTY INFORMATION & REGISTRATION VERIFICATION

It is imperative that the selling dealer registers this machine with McConnel Limited before delivery to the end user – failure to do so may affect the validity of the machine warranty.

To register machines go to the McConnel Limited web site at www.mcconnel.com, log onto 'Dealer Inside' and select the 'Machine Registration button' which can be found in the Service Section of the site. Confirm to the customer that the machine has been registered in the section below.

Should you experience any problems registering a machine in this manner please contact the McConnel Service Department on 01584 875848.

Registration Verification

| |
|--|
| Dealer Name: |
| Dealer Address: |
| Customer Name: |
| Date of Warranty Registration:/...../..... Dealer Signature: |

NOTE TO CUSTOMER / OWNER

Please ensure that the above section above has been completed and signed by the selling dealer to verify that your machine has been registered with McConnel Limited.

IMPORTANT: During the initial 'bedding in' period of a new machine it is the customer's responsibility to regularly inspect all nuts, bolts and hose connections for tightness and re-tighten if required. New hydraulic connections occasionally weep small amounts of oil as the seals and joints settle in – where this occurs it can be cured by re-tightening the connection – *refer to torque settings chart below*. The tasks stated above should be performed on an hourly basis during the first day of work and at least daily thereafter as part of the machines general maintenance procedure.

TORQUE SETTINGS FOR HYDRAULIC FITTINGS

| HYDRAULIC HOSE ENDS | | |
|---------------------|---------|--------|
| BSP | Setting | Metric |
| 1/4" | 18 Nm | 19 mm |
| 3/8" | 31 Nm | 22 mm |
| 1/2" | 49 Nm | 27 mm |
| 5/8" | 60 Nm | 30 mm |
| 3/4" | 80 Nm | 32 mm |
| 1" | 125 Nm | 41 mm |
| 1.1/4" | 190 Nm | 50 mm |
| 1.1/2" | 250 Nm | 55 mm |
| 2" | 420 Nm | 70 mm |

| PORT ADAPTORS WITH BONDED SEALS | | |
|---------------------------------|---------|--------|
| BSP | Setting | Metric |
| 1/4" | 34 Nm | 19 mm |
| 3/8" | 47 Nm | 22 mm |
| 1/2" | 102 Nm | 27 mm |
| 5/8" | 122 Nm | 30 mm |
| 3/4" | 149 Nm | 32 mm |
| 1" | 203 Nm | 41 mm |
| 1.1/4" | 305 Nm | 50 mm |
| 1.1/2" | 305 Nm | 55 mm |
| 2" | 400 Nm | 70 mm |

WARRANTY POLICY

WARRANTY REGISTRATION

All machines must be registered, by the selling dealer with McConnel Ltd, before delivery to the end user. On receipt of the goods it is the buyer's responsibility to check that the Verification of Warranty Registration in the Operator's Manual has been completed by the selling dealer.

1. LIMITED WARRANTIES

- 1.01. All machines supplied by McConnel Limited are warranted to be free from defects in material and workmanship from the date of sale to the original purchaser for a period of 12 months, unless a different period is specified.
- 1.02. All spare parts supplied by McConnel Limited are warranted to be free from defects in material and workmanship from the date of sale to the original purchaser for a period of 6 months.
- 1.03. The manufacturer will replace or repair for the purchaser any part or parts found, upon examination at its factory, to be defective under normal use and service due to defects in material or workmanship. Returned parts must be complete and unexamined.
- 1.04. This warranty does not apply to any part of the goods, which has been subjected to improper or abnormal use, negligence, alteration, modification, fitment of non-genuine parts, accident damage, or damage resulting from contact with overhead power lines, damage caused by foreign objects (e.g. stones, iron, material other than vegetation), failure due to lack of maintenance, use of incorrect oil or lubricants, contamination of the oil, or which has served its normal life. This warranty does not apply to any expendable items such as blades, flails, flap kits, skids, soil engaging parts, shields, guards, wear pads or pneumatic tyres.
- 1.05. Temporary repairs and consequential loss - i.e. oil, downtime and associated parts are specifically excluded from the warranty.
- 1.06. Warranty on hoses is limited to 12 months and does not include hoses which have suffered external damage. Only complete hoses may be returned under warranty, any which have been cut or repaired will be rejected.
- 1.07. Machines must be repaired immediately a problem arises. Continued use of the machine after a problem has occurred can result in further component failures, for which McConnel Ltd cannot be held liable, and may have safety implications.
- 1.08. Except as provided herein, no employee, agent, dealer or other person is authorised to give any warranties of any nature on behalf of McConnel Ltd.
- 1.09. For machine warranty periods in excess of 12 months the following additional exclusions shall apply:
 - 1) Hoses, external seals, exposed pipes and hydraulic tank breathers.
 - 2) Filters.
 - 3) Rubber mountings.
 - 4) External electric wiring.
- 1.10. All service work, particularly filter changes, must be carried out in accordance with the manufacturer's service schedule. Failure to comply will invalidate the warranty. In the event of a claim, proof of the service work being carried out may be required.

NB Warranty cover will be invalid if any non-genuine parts have been fitted or used. Use of non-genuine parts may seriously affect the machine's performance and safety. McConnel Ltd cannot be held responsible for any failures or safety implications that arise due to the use of non-genuine parts.

2. REMEDIES AND PROCEDURES

- 2.01. The warranty is not effective unless the Selling Dealer registers the machine, via the McConnel web site and confirms the registration to the purchaser by completing the confirmation form in the operator's manual.
- 2.02. Any fault must be reported to an authorised McConnel dealer as soon as it occurs. Continued use of a machine, after a fault has occurred, can result in further component failure for which McConnel Ltd cannot be held liable.
- 2.03. Repairs should be undertaken within two days of the failure. Claims submitted for repairs undertaken more than 2 weeks after a failure has occurred, or 2 days after the parts were supplied will be rejected, unless the delay has been authorised by McConnel Ltd.
- 2.04. All claims must be submitted, by an authorised McConnel Service Dealer, within 30 days of the date of repair.
- 2.05. Following examination of the claim and parts the manufacture will pay, at their discretion, for any valid claim the cost of any parts and an appropriate labour allowance if applicable.
- 2.06. The submission of a claim is not a guarantee of payment.
- 2.07. Any decision reached by McConnel Ltd. is final.

3. LIMITATION OF LIABILITY

- 3.01. The manufacturer disclaims any express (except as set forth herein) and implied warranties with respect to the goods including, but not limited to, merchantability and fitness for a particular purpose.
- 3.02. The manufacturer makes no warranty as to the design, capability, capacity or suitability for use of the goods.
- 3.03. Except as provided herein, the manufacturer shall have no liability or responsibility to the purchaser or any other person or entity with respect to any liability, loss, or damage caused or alleged to be caused directly or indirectly by the goods including, but not limited to, any indirect, special, consequential, or incidental damages resulting from the use or operation of the goods or any breach of this warranty. Notwithstanding the above limitations and warranties, the manufacturer's liability hereunder for damages incurred by the purchaser or others shall not exceed the price of the goods.
- 3.04. No action arising out of any claimed breach of this warranty or transactions under this warranty may be brought more than one (1) year after the cause of the action has occurred.

4. MISCELLANEOUS

- 4.01. The manufacturer may waive compliance with any of the terms of this limited warranty, but no waiver of any terms shall be deemed to be a waiver of any other term.
- 4.02. If any provision of this limited warranty shall violate any applicable law and is held to be unenforceable, then the invalidity of such provision shall not invalidate any other provisions herein.
- 4.03. Applicable law may provide rights and benefits to the purchaser in addition to those provided herein.



DECLARATION OF CONFORMITY

Conforming to EU Machinery Directive 2006/42/EC

We,

McCONNEL LIMITED, Temeside Works, Ludlow, Shropshire SY8 1JL, UK

Hereby declare that:

The Product; Hydraulic Arm Mounted Ditch Cleaner / Rotary Ditcher

Product Code; DC58

Serial No. & Date Type

Manufactured in; United Kingdom

Complies with the required provisions of the Machinery Directive 2006/42/EC
The machinery directive is supported by the following harmonized standards;

- BS EN ISO 14121-1 (2007) Safety of machinery - Risk assessment, Part 1: Principles Part 2: practical guide and examples of methods.
- BS EN ISO 12100-1 (2010) Safety of machinery - Part 1: Basic terminology and methodology Part 2: Technical principles.
- BS EN 349(1993)+ A1 (2008) Safety of machinery - Minimum distances to avoid the entrapment with human body parts.
- BS EN 953 (1998) Safety of machinery - Guards General requirements for the design and construction of fixed and movable guards.
- BS EN 982(1996)+ A1 (2008) Safety requirements for fluid power systems and their components. Hydraulics

McCONNEL LIMITED operates an ISO 9001:2008 quality management system, certificate number: FM25970.

This system is continually assessed by the;
British Standards Institution (BSI), Beech House, Milton Keynes, MK14 6ES, UK
BSI is accredited by UK Accreditation Service, accreditation number: UKAS 003.
The EC declaration only applies if the machine stated above is used in accordance with the operating instructions.

Signed *Responsible Person*
CHRISTIAN DAVIES on behalf of McCONNEL LIMITED

Status: General Manager

Date: May 2011

LIST OF CONTENTS

| | <i>Page No.</i> |
|--|-----------------|
| Operator Section | |
| General Information | 1 |
| Safety Information | 2 |
| Flows & Pressures | 7 |
| Fitting | 7 |
| Back Pressure Valve | 8 |
| Operation | 9 |
| Maintenance | 10 |
| | |
| Parts Section | |
| Main Assembly | 13 |
| Hydraulic Operation Models | 17 |
| Back Pressure Valve | 21 |
| Hydraulic Hoses & Diverter Valve Connections | 23 |
| Blade Options | 24 |

GENERAL INFORMATION

Read this manual before fitting or operating the machine. Whenever any doubt exists contact your dealer or McConnel Service Department for advice and assistance.

Use only McConnel 'Genuine Service Parts' on McConnel equipment and machines.

DEFINITIONS: The following definitions apply throughout this manual:

WARNING:

An operating procedure, technique etc., which can result in personal injury or loss of life if not observed carefully.

CAUTION:

An operating procedure, technique etc., which can result in the damage of either machine or equipment if not observed carefully.

NOTE:

An operating procedure, technique etc., which is considered essential to emphasize.

LEFT AND RIGHT HAND:

This term is applicable to the machine when fitted to the tractor and viewed from the rear, this also applies to tractor references.

To be assured of the latest design improvements purchase your '**Genuine Replacements**' from the **Original Equipment Manufacturer: McCONNEL LIMITED** through your local Dealer or Stockist.

Always quote:

- **Machine Type**
- **Serial Number**
- **Part Number**

| | | |
|---|----------------|--------------------|
| Record the Serial No. of your machine on this page and always quote this number when ordering spares along with the type and model of tractor your machine is fitted to. | | |
| Machine Serial No. | Model Details: | Installation Date: |
| Dealer Name: | | Dealer Telephone: |
| Dealer Address: | | |



SAFETY INFORMATION

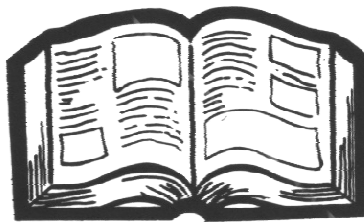

SAFETY INFORMATION

This machine has the potential to be extremely dangerous, in the wrong hands it can kill or maim. It is therefore imperative that the owner, and the operator of this machine, read the following section to ensure that they are both fully aware of the dangers that do, or may exist, and their responsibilities surrounding its use.

The operator of this machine is responsible not only for their own safety but equally for the safety of others who may come into the close proximity of the machine, as the owner you are responsible for both.

POTENTIAL SIGNIFICANT DANGERS ASSOCIATED WITH THE USE OF THIS MACHINE:

- ▲ *Being hit by debris thrown by rotating components.*
- ▲ *Being hit by machine parts ejected through damage during use.*
- ▲ *Being caught on a rotating power take-off (PTO) shaft.*
- ▲ *Being caught in other moving parts i.e.: belts, pulleys and cutting heads.*
- ▲ *Electrocution from Overhead Power Lines (by contact with or 'flashover' from).*
- ▲ *Being hit by cutting heads or machine arms as they move.*
- ▲ *Becoming trapped between tractor and machine when hitching or unhitching.*
- ▲ *Tractor overbalancing when machine arm is extended.*
- ▲ *Injection of high pressure oil from hydraulic hoses or couplings.*
- ▲ *Machine overbalancing when freestanding (out of use).*
- ▲ *Road traffic accidents due to collision or debris on the road.*

BEFORE USING THIS MACHINE YOU MUST:

- ▲ *Ensure you read all sections of the operator handbook.*
- ▲ *Ensure the operator is, or has been, properly trained to use the machine.*
- ▲ *Ensure the operator has been issued with and reads the operator handbook.*
- ▲ *Ensure the operator understands and follows the instructions in operator handbook.*
- ▲ *Ensure the tractor front, rear and side(s) are fitted with metal mesh or polycarbonate guards of suitable size and strength to protect the operator against thrown debris or parts.*
- ▲ *Ensure tractor guards are fitted correctly, are undamaged and kept properly maintained.*

- ▲ *Ensure that all machine guards are in position, are undamaged, and are kept maintained in accordance with the manufacturer's recommendations.*
- ▲ *Ensure flails and their fixings are of a type recommended by the manufacturer, are securely attached and that none are missing or damaged.*
- ▲ *Ensure hydraulic pipes are carefully and correctly routed to avoid damage by chaffing, stretching or pinching and that they are held in place with the correct fittings.*
- ▲ *Always follow the manufacturer's instructions for attachment and removal of the machine from the tractor.*
- ▲ *Check that the machine fittings and couplings are in good condition.*
- ▲ *Ensure the tractor meets the minimum weight recommendations of the machine manufacturer and that ballast is used as necessary.*
- ▲ *Always inspect the work area thoroughly before starting to note obstacles and remove wire, bottles, cans and other debris.*
- ▲ *Use clear suitably sized warning signs to alert others to the nature of the machine working within that area. Signs should be placed at both ends of the work site. (It is recommended that signs used are of a size and type specified by the Department of Transport and positioned in accordance with their and the Local Highways Authority guidelines).*
- ▲ *Ensure the operator is protected from noise. Ear defenders should be worn and tractor cab doors and windows must be kept closed. Machine controls should be routed through proprietary openings in the cab to enable all windows to be shut fully.*
- ▲ *Always work at a safe speed taking account of the conditions i.e.: terrain, highway proximity and obstacles around and above the machine.*
- ▲ *Extra special attention should be applied to Overhead Power Lines. Some of our machines are capable of reach in excess of 8 metres (26 feet) this means they have the potential to well exceed, by possibly 3 metres (9' 9"), the lowest legal minimum height of 5.2 metres from the ground for 11,000 and 33,000 volt power lines. It cannot be stressed enough the dangers that surround this capability, it is therefore vital that the operator is fully aware of the maximum height and reach of the machine, and that they are fully conversant with all aspects regarding the safe minimum distances that apply when working with machines in close proximity to Power Lines. (Further information on this subject can be obtained from the Health & Safety Executive or your Local Power Company).*
- ▲ *Always disengage the machine, kill the tractor engine, remove and pocket the key before dismounting for any reason.*
- ▲ *Always clear up all debris left at the work area, it may cause hazard to others.*
- ▲ *Always ensure when you remove your machine from the tractor that it is left in a safe and stable position using the stands and props provided and secured if necessary.*

WHEN NOT TO USE THIS MACHINE:

- ▲ *Never attempt to use this machine if you have not been trained to do so.*
- ▲ *Never uses a machine until you have read and understood the operator handbook, are familiar with, and practiced the controls.*
- ▲ *Never use a machine that is poorly maintained.*
- ▲ *Never use a machine if guards are missing or damaged.*
- ▲ *Never use a machine on which the hydraulic system shows signs of wear or damage.*
- ▲ *Never fit, or use, a machine on a tractor that does not meet the manufacturer's minimum specification level.*
- ▲ *Never use a machine fitted to a tractor that does not have suitable front, rear and side(s) cab guarding made of metal mesh or polycarbonate.*
- ▲ *Never use the machine if the tractor cab guarding is damaged, deteriorating or badly fitted.*
- ▲ *Never turn a machine cutting head to an angle that causes debris to be ejected towards the cab.*
- ▲ *Never start or continue to work a machine if people are nearby or approaching - Stop and wait until they are at a safe distance before continuing.*
- ▲ *Never attempt to use a machine on materials in excess of its capability.*
- ▲ *Never use a machine to perform a task it has not been designed to do.*
- ▲ *Never operate the tractor or machine controls from any position other than from the driving seat, especially whilst hitching or unhitching the machine.*
- ▲ *Never carry out maintenance of a machine or a tractor whilst the engine is running – the engine should be switched off, the key removed and pocketed.*
- ▲ *Never leave a machine unattended in a raised position – it should be lowered to the ground in a safe position on a level firm site.*
- ▲ *Never leave a tractor with the key in or the engine running.*
- ▲ *Never carry out maintenance on any part or component of a machine that is raised unless that part or component has been properly substantially braced or supported.*
- ▲ *Never attempt to detect a hydraulic leak with your hand – use a piece of cardboard.*
- ▲ *Never allow children near to, or play on, a tractor or machine under any circumstances.*

ADDITIONAL SAFETY ADVICE

TRAINING

Operators need to be competent and fully capable of operating this machine in a safe and efficient way prior to attempting to use it in any public place. We advise therefore that the prospective operator make use of relevant training courses available such as those run by the Agricultural Training Board, Agricultural Colleges, Dealers and McConnel.

WORKING IN PUBLIC PLACES

When working in public places such as roadsides, consideration should be paid to others in the vicinity. Stop the machine immediately when pedestrians, cyclists and horse riders etc. pass. Restart only when they are at a distance that causes no risk to their safety.

WARNING SIGNS

It is advisable that any working area be covered by suitable warning signs and statutory in public places. Signs should be highly visible and well placed in order to give clear advanced warning of the hazard. Contact the Department of Transport or your Local Highways Authority to obtain detailed information on this subject. The latter should be contacted prior to working on the public highway advising them of the time and location of the intended work asking what is required by way of signs and procedure. – ‘*Non-authorized placement of road signs may create offences under the Highways Act*’.

SUGGESTED WARNING SIGNS REQUIRED

“Road works ahead” warning sign with a supplementary “Hedge cutting” plate. “For 1 mile” or appropriate shorter distance may be added to the plate.

“Road narrows” warning sign with supplementary “Single file traffic” plate.

White on blue “Keep right” arrow sign on rear of machine.

USE OF WARNING SIGNS

- ▲ *On two way roads one set of signs is needed facing traffic in each direction.*
- ▲ *Work should be within 1 mile of the signs.*
- ▲ *Work only when visibility is good and at times of low risk e.g.: NOT during ‘rush-hour’.*
- ▲ *Vehicles should have an amber flashing beacon.*
- ▲ *Ideally, vehicles should be conspicuously coloured.*
- ▲ *Debris should be removed from the road and path as soon as practicable, and at regular intervals, wearing high visibility clothing and before removing the hazard warning signs.*
- ▲ *Collect all road signs promptly when the job is completed.*

Although the information given here covers a wide range of safety subjects it is impossible to predict every eventuality that can occur under differing circumstances whilst operating this machine. No advice given here can replace ‘good common sense’ and ‘total awareness’ at all times but will go a long way towards the safe use of your McConnel machine.

FLOWS & PRESSURES – *For reliable working*

HIGH SPEED VERSION

| | | |
|-----------------------------|---|-----------|
| Maximum continuous flow | - | 100 L/min |
| Maximum continuous speed | - | 500RPM |
| Maximum continuous pressure | - | 210 Bar |

PA50,52,53,59
540 PTO MAX

PA55 - 7700T
430 PTO MAX

STANDARD SPEED VERSION

| | | |
|-----------------------------|---|-----------|
| Maximum continuous flow | - | 125 L/min |
| Maximum continuous speed | - | 320RPM |
| Maximum continuous pressure | - | 210 Bar |

PA50,52,53,59
540 PTO MAX

PA55 - 7700T
540 PTO MAX

OPERATING CONDITIONS FOR BOTH VERSIONS

| | | |
|-----------------------------|---|--------------------------|
| Return line pressure | - | 2 Bar min to 20 Bar max* |
| Maximum drain line pressure | - | 5 Bar |
| Optimum Viscosity | - | 35 – 200cSt |
| Optimum temperature | - | 40 - 70°C |
| Fluid Cleanliness | - | NAS 9/ ISO 18/15 |

*** On non electric rotor control valve or non piston machines a Back Pressure Kit should be fitted or motor life will be seriously reduced.**

FITTING

The Rotary Ditcher and Rotary Cleaner can be fitted only to Power Arm machines that are equipped with hydraulic slewing/breakaway action.

The procedure for fitting the units is as follows:

Flailhead Removal

- Disconnect the flailhead hoses on both sides of the hose junction bracket.
- Unbolt the hose junction bracket from the angling jaw plate.
- Unbolt the flailhead from the mounting tube and remove together with the hoses and the junction bracket - *plug or cover the ends of the hoses to prevent access of contaminants during storage.*

Fitting of Ditcher/Cleaner Unit

- Bolt the Ditcher/Cleaner to the dipper arm ensuring that the top plate is horizontal when the angling ram is approximately half extended - *i.e. at the mid-point of its stroke.*

On machines with piston hydraulics connect 'T' connection to the drain line on the machine *or* connect motor drain line as supplied in the kit (*see below*).

Using Drain Line Supplied with the Kit

- If using the drain line supplied with the kit the hose guards should be removed from the Power Arms and the $\frac{3}{8}$ " BSP drain hose from the Ditcher/Cleaner secured alongside, and attached to, the existing Power Arm hoses using the hose ties supplied.
Note: - *Ensure that that sufficient 'slack' is allowed for over the arm pivots to permit the hoses to flex properly.*
- Refit hose guards.
- Unscrew the breather from the tank top and remove the 'O' ring from the union.
- Fit the $\frac{3}{4}$ " BSP M/F adaptor onto the breather union together with the $\frac{3}{4}$ " BSP bonded washer supplied.
- Refit the breather using the existing 'O' ring.
- Screw the $\frac{3}{4}$ " BSP M/M union into the side of the breather extended adaptor using the $\frac{3}{4}$ " BSP bonded washer supplied.
- Connect the motor drain hose.
- Connect up the 1" BSP hoses to the existing flail hoses using the 1" BSP union provided to give the rotation of cut required – see *diagram below*.

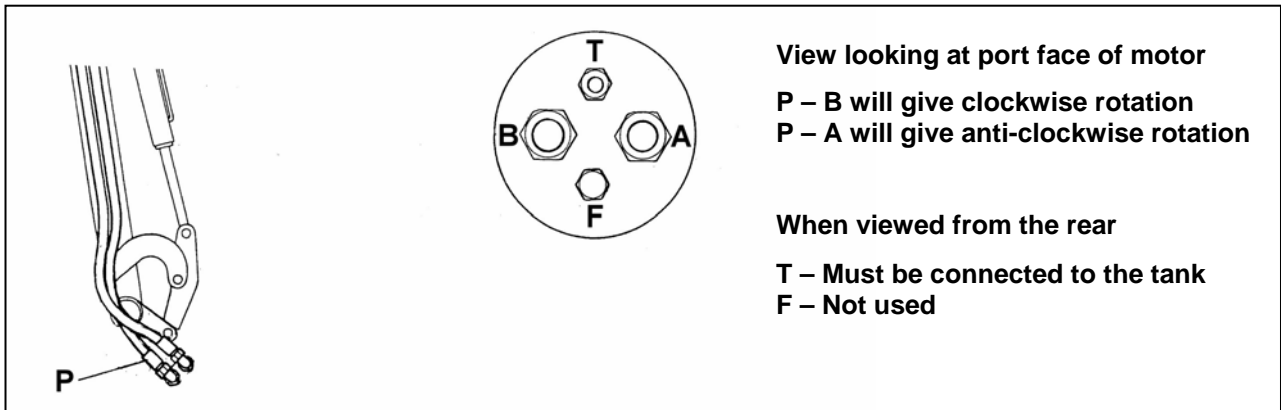

BACK PRESSURE KIT - *Gear Hydraulic machines only*

Note: Electric Reverse Gear and Piston Machines DO NOT require a Back Pressure Kit.

A Back Pressure Kit is provided to prevent the motor from becoming 'starved' of oil during normal operation and whilst stopping and starting. The kit must be fitted in the return line hose from the motor and normally fits directly onto the motor control valve. This installation is as follows:

- The tank return 'T' (*complete with hose*) is disconnected from the valve, the back pressure valve is fitted onto the union and the 'T' reconnected onto the free end of the back pressure valve.
- Disconnect the pressure hose from the pump, fit the 1" BSP 'T' piece to the pressure port adaptor and reconnect the pressure hose.
- Complete the installation by joining the back pressure valve and the pressure line 'T' using the $\frac{1}{4}$ " hose provided.

NOTE: *This installation allows the operator to select opposite rotation to clear a blockage.*

CAUTION

On reverting back to hedgecutting/mowing the Back Pressure Kit MUST BE REMOVED

OPERATION

Read the Book First

Before attempting to operate this machine it is imperative that both the owner and operator has read, and fully understood, not only this manual but also that of any machine it is attached to, and that they are fully conversant with all operation and safety aspects surrounding its use.

- Check all nuts and bolts are tight and that the 1" BSP hose connections give the desired rotation of cut when the lever is operated such: -

Upward Cutting = Clockwise Rotation
Downward Cutting = Anti-clockwise Rotation } *When viewed from the front*

If found to be opposite to above the 1" BSP hoses must be interchanged at the jointing union.

- Examine the ditch for obstacles and dangerous materials e.g. metal, wire, glass, large stones etc. and remove before commencing.

ADJUSTMENTS

Approach Angle

The Ditch Cleaner can be rotated on its mounting plate to give 5 approach angles to the ditch - this is achieved by removing the 3 mounting bolts enabling the main body to be pivoted about its central spindle to the required position.

Cutters

The double-edged blades and paddles can be adjusted to allow cutting with either a clockwise or anti-clockwise rotation - if using single-edged blades an opposite hand set of blades will be needed if it is required to cut with the opposite rotation.

Blades

The double-edged blades, which are slotted, pivot about the outer mounting bolt to allow for rotation of cut. For anti-clockwise cutting action (*when viewed from the front*) the blade is pivoted clockwise to the limit of the slot and visa-versa.

Blade options include:

Double edged blade (*Part No. 41.216.01*) – Good cutting performance in harder soils

Single edged blade (*Part No. 41936.01*) – L/H Standard Duty – good throwing performance.

Single edged blade (*Part No. 41936.02*) – R/H Standard Duty – good throwing performance.

Single edged blade (*Part No. 41936.03*) – L/H Heavy Duty – good throwing performance.

Single edged blade (*Part No. 41936.04*) – R/H Heavy Duty – good throwing performance.

NOTE: Blades should be fitted in sets of 3 and be of similar weight in order to maintain rotor balance.

Paddles

The function of the paddles is to aid the excavation of material from the cutting area. There are 2 possible positions available for mounting the paddles; the correct position will depend on the direction of cut – whichever the direction, the paddles should always be fitted with the paddle face leading and the paddle body sloping backwards from the rotation of cut.

Spoil Deflector

The spoil deflector consists of two sections, the first is fixed whilst the second pivots to allow a choice of 8 positions to control and guide the direction of thrown spoil. The adjustments allow the angle of cut and the outboard destination of the spoil to be selected for both right and left hand mounted machines. To deflect the spoil inboard a reverse chute and blade kit is available.

MAINTENANCE

Ditch Cleaner Shaft Seal Replacement

1. Slacken evenly, the eight bolts (*item 330*) to release the output housing from the torque unit. NOTE THE ORIENTATION OF THE HOUSING TO THE TORQUE UNIT.
2. Carefully lift off the output housing taking care not to disturb the rotor in the torque unit when disengaging the spline drive.
3. Unlock washer (*item 270*) and release the nut (*item 260*) which holds the bearing under pre-load, remove both.
4. Supporting the housing (*item 160*) press the shaft out from the splined end. This will remove the cone of the inner bearing (*item 240*) from the shaft.
5. Remove from housing the bearing cone from the inner bearing (*item 240*).
6. Remove the shaft seal (*item 280*).
7. Clean all parts thoroughly.

Re-Assembly

1. Press a new shaft seal (*item 280*) carefully and squarely into the output housing (*item 160*).
2. Press the bearing cup from the inner bearing (*item 240*) back into its bore in the housing, taking care to ensure it faces the correct way.
3. Fill the area between the end of the housing and the shaft seal with lithium based grease as stated on the attached assembly drawing.
4. Holding the keyed end of the shaft (*item 200*) vertically in a vice, lower the output housing onto it so that it sits squarely on the outer bearing (*item 230*).
5. Warm slightly, the inner bearing cone to help with assembly, then press it on to the shaft until it sits in the cone, ensuring that the bearing is installed the correct way.
6. Re-fit the locking tab and the locking nut and tighten the unit to 24-lbf ft.
7. Re-fit the locking tab. If the tab does not line up with any slot in the nut, tighten the nut to line up a tab with a slot in the nut.
8. Spin the housing to ensure the bearings are seated correctly and that there is no end play on them.
9. Check the 'O' ring (*item 300*) in the housing face is O K, then lower it onto the torque unit, taking care to align the splines correctly and that the output housing to the torque unit orientation is as it was before stripdown.
10. Re-fit and tighten evenly, the eight bolts (*item 330*). Check regularly during tightening that the shaft is free to rotate, thus ensuring that the alignment of the output housing and torque unit is correct.
11. Tighten the eight bolts to the recommended torque setting (*see diagram on following page*).

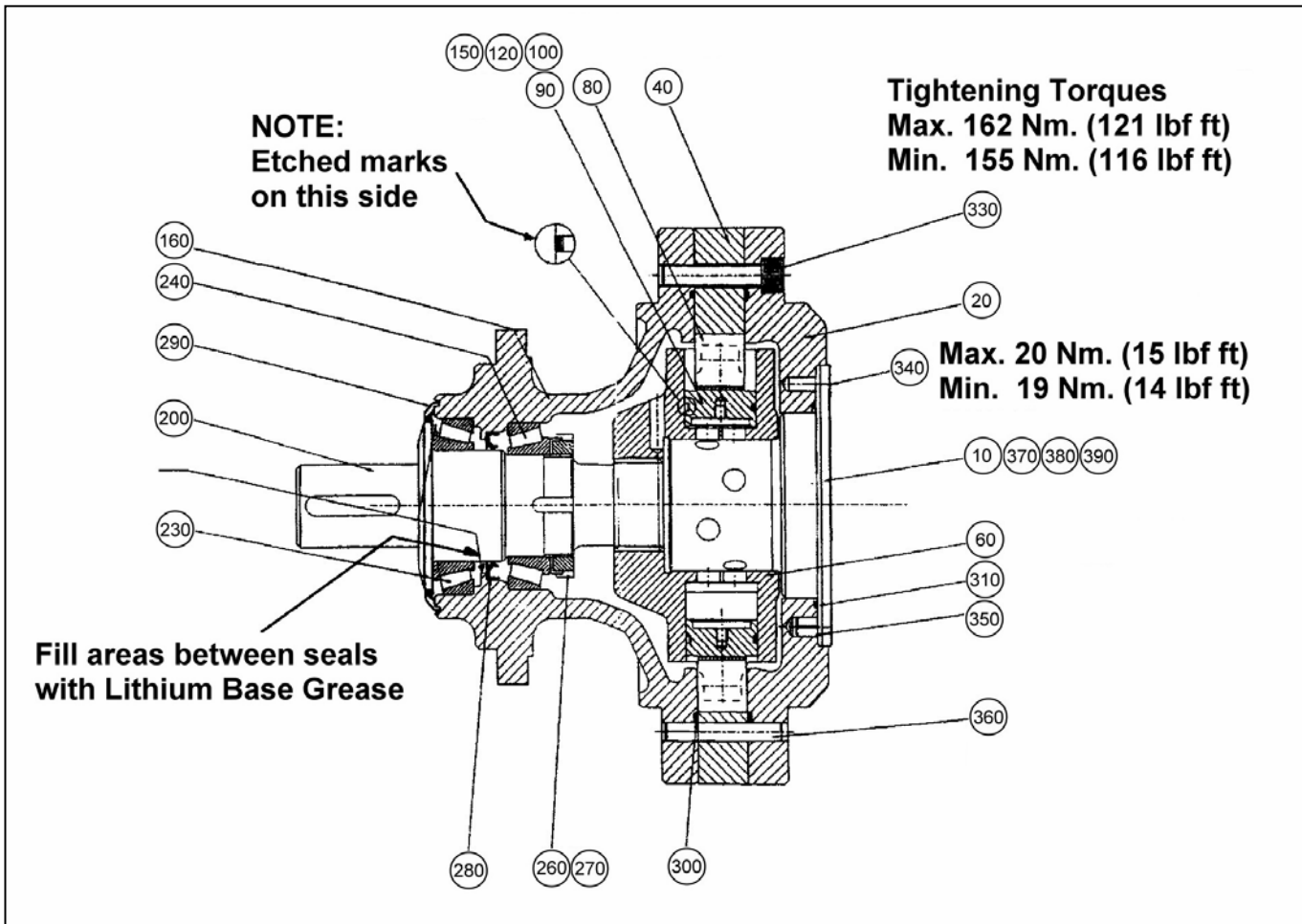

PARTS SECTION

For best performance...

USE ONLY McCONNEL SERVICE PARTS

To be assured of the latest design improvements purchase your '**Genuine Replacements**' from the Original Equipment Manufacturer: **McCONNEL LIMITED** through your local Dealer or Stockist.

Always quote:

- **Machine Type**
- **Serial Number**
- **Part Number**

Design Improvements may have altered some of the parts listed in this manual – the latest part will always be supplied when it is interchangeable with an earlier one.



ROTARY DITCHER/DITCH CLEANER

Modules:

- 6600300 – Rotary Ditcher L/H Build
- 6600301 – Rotary Ditcher R/H Build
- 6600302 – Ditch Cleaner L/H Build
- 6600303 – Ditch Cleaner R/H Build

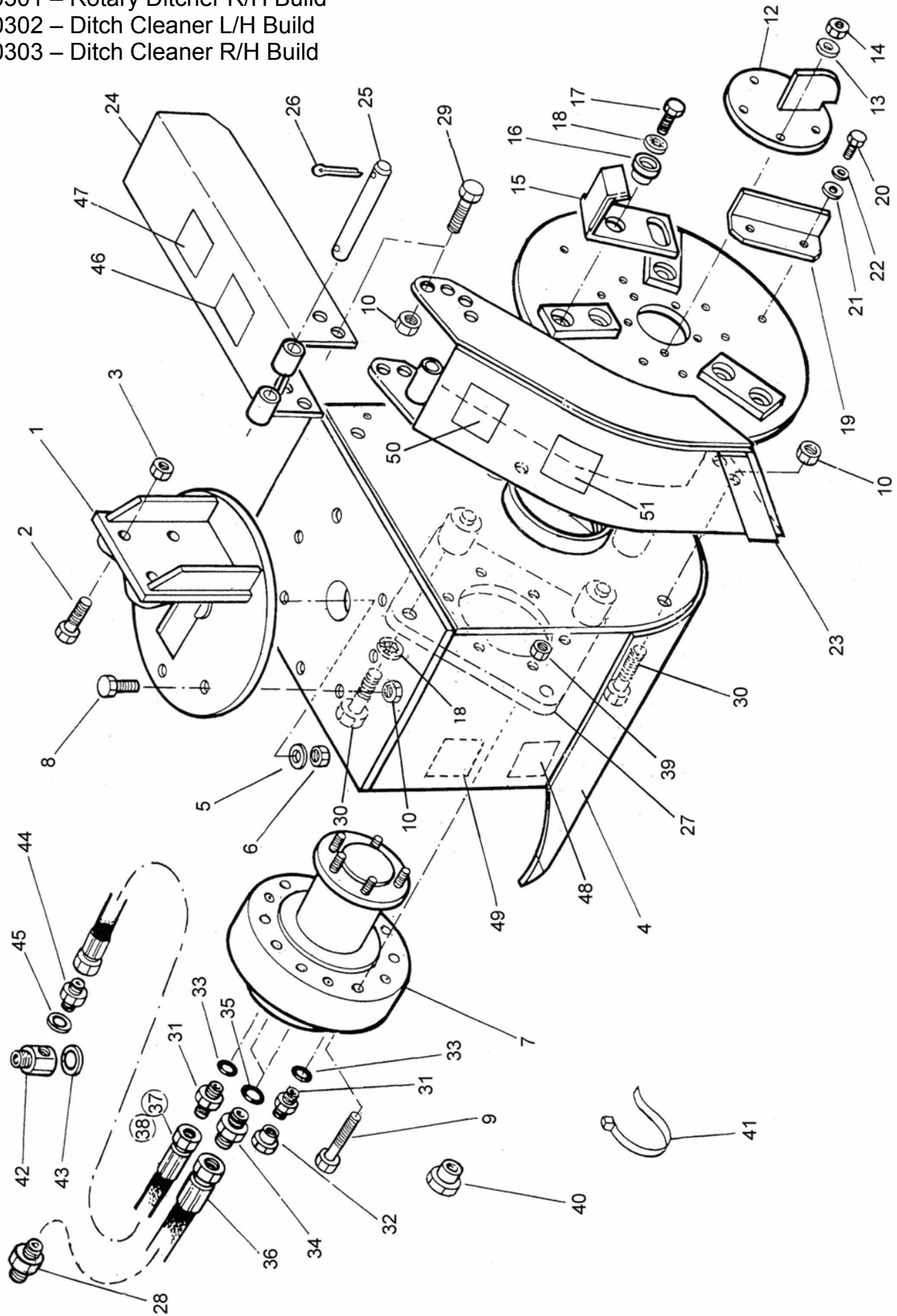



ROTARY DITCHER/DITCH CLEANER

| REF. | QTY. | PART No. | DESCRIPTION |
|------|------|----------------|---|
| | | 6600300 | ROTARY DITCHER ASSEMBLY - L/H build |
| | | 6600301 | ROTARY DITCHER ASSEMBLY - R/H build |
| | | 6600302 | DITCH CLEANER ASSEMBLY - L/H build |
| | | 6600303 | DITCH CLEANER ASSEMBLY - R/H build |
| 1 | 1 | 41.210.01 | MOUNTING BRACKET |
| 2 | 4 | 0211226 | BOLT |
| 3 | 6 | 0141006 | SELF-LOCKING NUT |
| 4 | 1 | 41.208.02 | HOUSING |
| 5 | 1 | 41.214.01 | WASHER |
| 6 | 1 | 9143009 | SELF-LOCKING NUT |
| 7 | 1 | 8301289 | HYDRAULIC MOTOR - Ditch Cleaner |
| | 1 | 8301298 | HYDRAULIC MOTOR - Rotary Ditcher |
| 8 | 3 | 9213097 | BOLT |
| 9 | 6 | 9213186 | BOLT |
| 10 | 7 | 9143007 | SELF-LOCKING NUT |
| 11 | 1 | 41.209.01 | CUTTING DISC |
| 12 | 1 | 41.232.01 | CENTRE DEFLECTOR |
| 13 | 5 | 05.281.14 | PLAIN WASHER |
| 14 | 5 | 05.968.06 | SELF-LOCKING NUT |
| 15 | 3 | 41.216.01 | BLADE - Double Edged (<i>Illustrated</i>) |
| | 3 | 41936.01 | BLADE - Single Edged L/H Std. Duty |
| | 3 | 41936.02 | BLADE - Single Edged R/H Std. Duty |
| | 3 | 41936.03 | BLADE - Single Edged L/H Heavy Duty |
| | 3 | 41936.04 | BLADE - Single Edged R/H Heavy Duty |
| 16 | 6 | 41.231.01 | COLLAR |
| 17 | 6 | 0311126 | BOLT |
| 18 | 10 | 05.283.04 | SHAKEPROOF WASHER |
| 19 | 3 | 41.215.01 | PADDLE |
| 20 | 6 | 9313056 | SETSCREW |
| 21 | 6 | 9100106 | PLAIN WASHER |
| 22 | 6 | 9100206 | SPRING WASHER |
| 23 | 1 | 41928.01 | SPOIL DEFLECTOR (FIXED) - L/H Working |
| | 1 | 41928.02 | SPOIL DEFLECTOR (FIXED) - R/H Working |
| 24 | 1 | 41929.01 | SPOIL DEFLECTOR (ADJUSTABLE) |
| 25 | 1 | 41.212.01 | PIVOT PIN |
| 26 | 2 | 9501406 | SPLIT PIN |
| 27 | 1 | 41927.02 | MOTOR MOUNTING ADAPTOR PLATE |
| 28 | 1 | 05.434.01 | UNION |
| 29 | 2 | 9313067 | SETCREW |
| 30 | 6 | 9313107 | SETSCREW |
| 31 | 2 | 08.955.06 | ADAPTOR |
| 32 | 1 | 05.433.04 | BLANKING CAP |
| 33 | 2 | 8600906 | O RING |
| 34 | 2 | 8581331 | ADAPTOR |
| 35 | 2 | 8600910 | O RING |



ROTARY DITCHER/DITCH CLEANER

Modules:

- 6600300 – Rotary Ditcher L/H Build
- 6600301 – Rotary Ditcher R/H Build
- 6600302 – Ditch Cleaner L/H Build
- 6600303 – Ditch Cleaner R/H Build

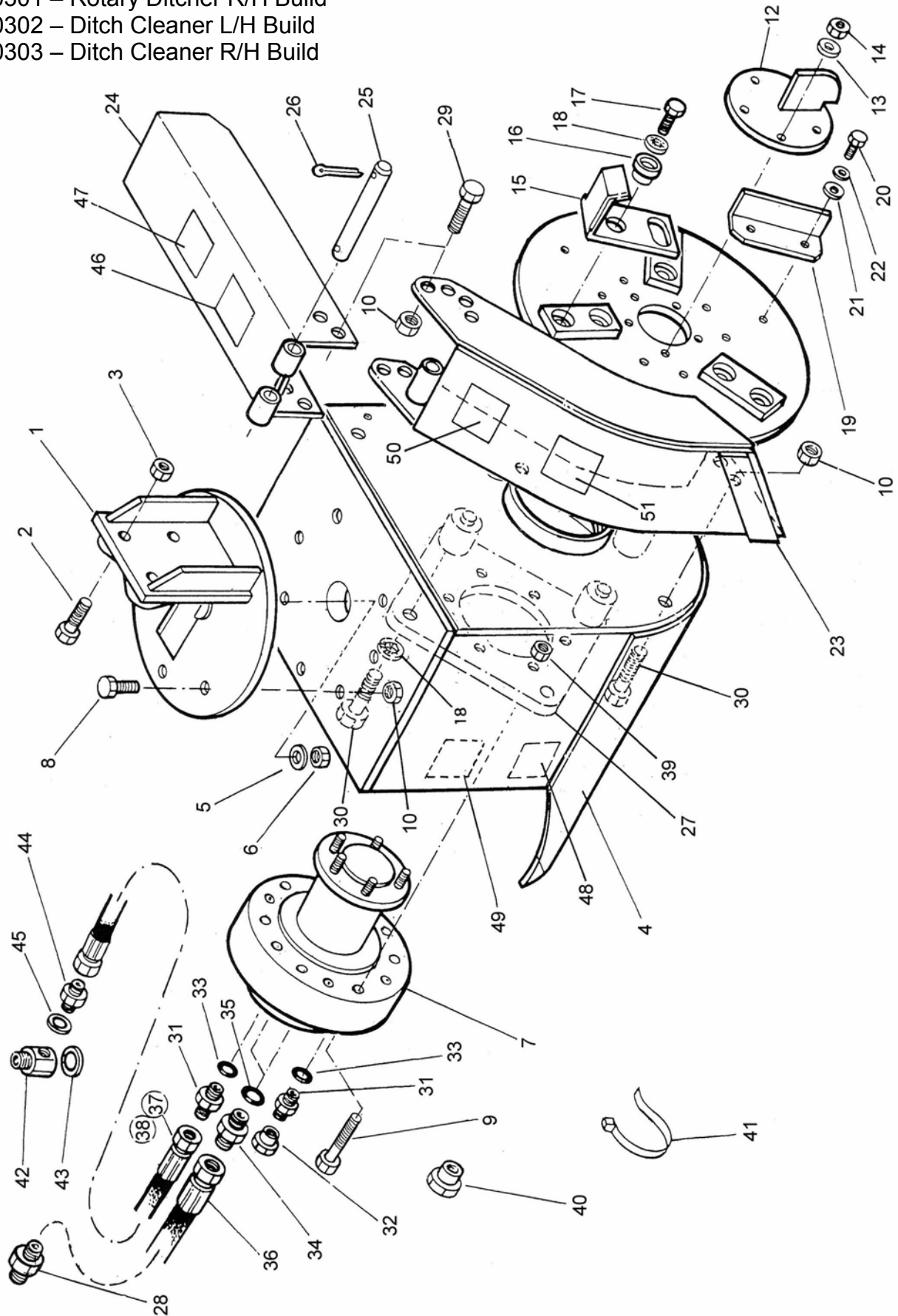



ROTARY DITCHER/DITCH CLEANER

| REF. | QTY. | PART No. | DESCRIPTION |
|------|------|----------------|---|
| 36 | 2 | 8501190 | HOSE - 1" BSP SF/90F x 41" Long |
| 37 | 1 | 8511433 | HOSE - 3/8" BSP SF/SF x 300" Long |
| 38 | 2 | 8511243 | HOSE - 3/8" BSP SF/SF x 42" Long |
| 39 | 6 | 9143006 | SELF-LOCKING NUT |
| 40 | 1 | G3812119 | BLANKING CAP - <i>Piston Hydraulic Machines</i> |
| 41 | 20 | 7196045 | HOSE TIE |
| 42 | 1 | 41.217.01 | SPECIAL ADAPTOR |
| 43 | 1 | 8650106 | BONDED SEAL |
| 44 | 1 | 6000113 | UNION |
| 45 | 1 | 8650103 | BONDED SEAL |
| 46 | 1 | 09.821.05 | DECAL - DANGER CUTTING HEAD |
| 47 | 1 | 09.821.08 | DECAL - SAFE WORKING ON HEAD |
| 48 | 1 | 09.821.10 | DECAL- KEEP NUTS TIGHT |
| 49 | 1 | 09.821.15 | DECAL - READ INSTRUCTION BOOK |
| 50 | 1 | 09.821.20 | DECAL - SHAFT ENTANGLEMENT |
| 51 | 1 | 09.821.04 | Decal - DANGER THROWN DEBRIS |
| | | 8699245 | SEAL KIT - For hydraulic motor |

ACCESSORIES - not illustrated

| | | | |
|--|---|----------------|------------------------------------|
| | | 6600310 | CHUTE & BLADE KIT - L/H |
| | 1 | 41928.01 | SPOIL CHUTE - L/H |
| | 3 | 41936.01 | BLADE - Single Edged L/H Std. Duty |
| | | 6600311 | CHUTE & BLADE KIT - R/H |
| | 1 | 41928.02 | SPOIL CHUTE - R/H |
| | 3 | 41936.02 | BLADE - Single Edged R/H Std. Duty |

HYDRAULIC OPERATION MODELS

Module:

- 6600400 – Ditch Cleaner L/H Build
- 6600401 – Ditch Cleaner R/H Build
- 6600402 – Rotary Ditcher L/H Build
- 6600403 – Rotary Ditcher R/H Build

Ditch Cleaner Left Hand Build Illustrated

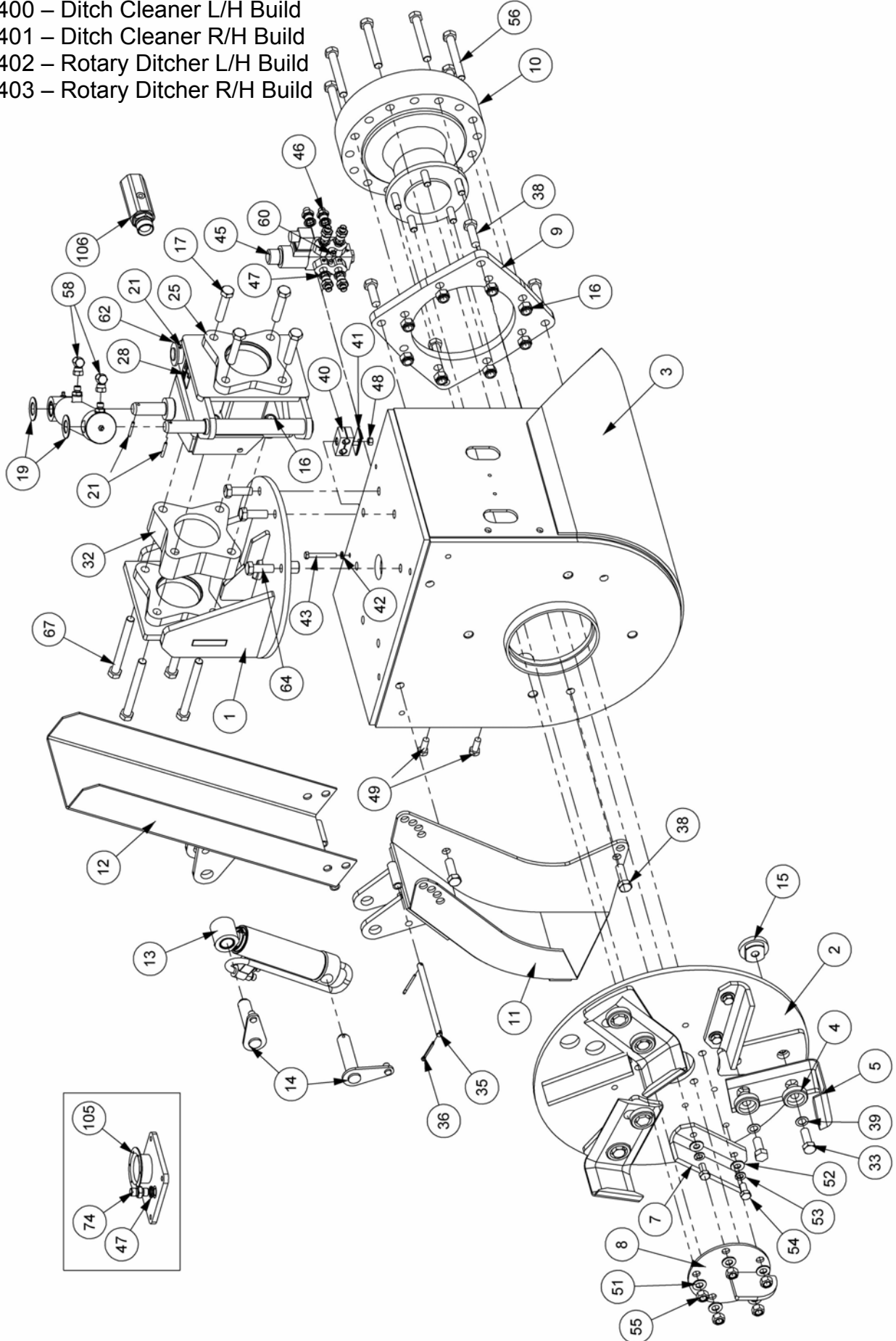



HYDRAULIC OPERATION MODELS

| REF. | QTY. | PART No. | DESCRIPTION |
|------|------|----------------|---|
| | | 6600400 | DITCH CLEANER (Hydraulic Operation) - L/H Build |
| | | 6600401 | DITCH CLEANER (Hydraulic Operation) - R/H Build |
| | | 6600402 | ROTARY DITCHER (Hydraulic Operation) - L/H Build |
| | | 6600403 | ROTARY DITCHER (Hydraulic Operation) - R/H Build |
| 1 | 1 | 41.210.02 | MOUNTING BRACKET |
| 2 | 1 | 41.209.02 | CUTTING DISC |
| 3 | 1 | 41.208.02 | MAIN HOUSING |
| 4 | 6 | 41.231.01 | COLLAR |
| 5 | 3 | 41.216.01 | BLADE - Double Edged (<i>Illustrated</i>) |
| | 3 | 41936.01 | BLADE - Single Edged L/H Std. Duty |
| | 3 | 41936.02 | BLADE - Single Edged R/H Std. Duty |
| | 3 | 41936.03 | BLADE - Single Edged L/H Heavy Duty |
| | 3 | 41936.04 | BLADE - Single Edged R/H Heavy Duty |
| 6 | 1 | 41.214.01 | WASHER |
| 7 | 3 | 41.215.01 | PADDLE |
| 8 | 1 | 41.232.01 | DEFLECTOR - CENTRE |
| 9 | 1 | 41927.01 | ADAPTOR PLATE - Ditch Cleaner |
| | 1 | 41927.02 | ADAPTOR PLATE - Rotary Ditcher |
| 10 | 1 | 8301289 | MOTOR - Ditch Cleaner |
| | 1 | 8301298 | MOTOR - Rotary Ditcher |
| 11 | 1 | 41928.03 | CHUTE (HYDRAULIC) - <i>L/H Build</i> |
| | 1 | 41928.04 | CHUTE (HYDRAULIC) - <i>R/H Build</i> |
| 12 | 1 | 41929.02 | DEFLECTOR (HYDRAULIC) |
| 13 | 1 | 43377.03 | CHUTE RAM ASSEMBLY (<i>uses Seal Kit 8699188</i>) |
| 14 | 2 | 7192024 | PIN |
| 15 | 3 | 41.209.03 | NUT SPECIAL |
| 16 | 16 | 0141006 | CLEVELOC NUT |
| 17 | 4 | 0211246 | BOLT |
| 18 | 1 | 0901121 | GREASE NIPPLE |
| 19 | 2 | 7192001 | WASHER |
| 20 | 1 | 09.987.03 | ORBITER RAM ASSEMBLY (<i>uses Seal Kit 8699188</i>) |
| 21 | 3 | 0425540 | SPRING DOWEL |
| 22 | 2 | 7101083 | LINK BUSH |
| 23 | 1 | 41.234.01 | BRACKET (FRONT) - <i>L/H Build</i> |
| | 1 | 41.234.02 | BRACKET (FRONT) - <i>R/H Build</i> |
| 24 | 1 | 41.235.02 | PIN |
| 25 | 1 | 41.233.01 | BRACKET (REAR) - <i>L/H Build</i> |
| | 1 | 41.233.02 | BRACKET (REAR) - <i>R/H Build</i> |
| 26 | 8 | 7135084 | CABLE TIE |
| 27 | 1 | 7213005 | HOSE ARMOUR |
| 28 | 2 | 02962764 | DECAL - PINCH POINTS |
| 29 | 2 | 8581172 | ADAPTOR |
| 30 | 6 | 8581169 | ADAPTOR |
| 31 | 2 | 8581320 | ADAPTER TEE |
| 32 | 1 | 7190453 | HEAD SPACER |
| 33 | 3 | 0211146 | BOLT |

continued...



HYDRAULIC OPERATION MODELS

| REF. | QTY. | PART No. | DESCRIPTION |
|------|------|-----------|---------------------------------|
| 34 | 3 | 0311126 | SCREW |
| 35 | 1 | 41.212.02 | PIN |
| 36 | 2 | 9501406 | SPLIT PIN |
| 37 | 4 | 0211446 | BOLT |
| 38 | 6 | 9313107 | SETSCREW |
| 39 | 10 | 05.283.04 | SHAKEPROOF WASHER |
| 40 | 1 | 7193065 | HOSE CLAMP |
| 41 | 3 | 7193066 | CLAMP PLATE |
| 42 | 3 | 9100204 | SPRING WASHER |
| 43 | 1 | 9213124 | BOLT |
| 44 | 1 | 21546.01 | SPACER - DIVERTER MOUNT |
| 45 | 1 | 41605.01 | DIVERTER VALVE |
| 46 | 6 | 8581115 | ADAPTOR |
| 47 | 7 | 8650103 | BONDED SEAL |
| 48 | 1 | 9143004 | SELF-LOCKING NUT |
| 49 | 2 | 9313066 | SETSCREW |
| 50 | 2 | 9143006 | SELF-LOCKING NUT |
| 51 | 5 | 05.281.14 | FLAT WASHER |
| 52 | 6 | 9100106 | FLAT WASHER |
| 53 | 6 | 9100206 | SPRING WASHER |
| 54 | 6 | 9313056 | SETSCREW |
| 55 | 5 | 05.968.06 | SELF LOCKING NUT |
| 56 | 8 | 0211366 | BOLT |
| 57 | 5 | 9143007 | SELF-LOCKING NUT |
| 58 | 2 | 8581190 | ADAPTOR ELBOW - 90° |
| 59 | 2 | 9100103 | FLAT WASHER |
| 60 | 2 | 9143003 | SELF-LOCKING NUT |
| 61 | 1 | 41928.40 | SPACER |
| 62 | 1 | 41.235.01 | PIN |
| 63 | 2 | 8650102 | BONDED SEAL |
| 64 | 3 | 9313097 | SETSCREW |
| 65 | 1 | 9143009 | SELF-LOCKING NUT |
| 66 | 2 | 9213123 | BOLT |
| 67 | 4 | 0211486 | BOLT |
| 68 | 4 | 05.434.01 | ADAPTOR |
| 69 | 10 | 7196045 | HOSE TIE |
| 70 | 1 | 3812119 | BLANKING CAP |
| 71 | 2 | 8600908 | O RING |
| 72 | 2 | 8600910 | O RING |
| 73 | 1 | 8650106 | BONDED SEAL |
| 74 | 4 | 6000113 | ADAPTOR |
| 75 | 2 | 8581387 | ADAPTOR |
| 76 | 1 | G3812368 | ADAPTOR |
| 77 | 1 | 09.821.10 | DECAL - KEEP NUTS TIGHT |
| 78 | 1 | 09.821.15 | DECAL - READ INSTRUCTION MANUAL |

continued...



HYDRAULIC OPERATION MODELS

| REF. | QTY. | PART No. | DESCRIPTION |
|------|------|-----------|----------------------------------|
| 79 | 1 | 09.821.20 | DECAL - SHAFT ENTANGLEMENT |
| 80 | 1 | 1335246 | SERIAL No. PLATE |
| 81 | 4 | 7103230 | POP RIVET |
| 82 | 2 | 8581170 | ADAPTOR |
| 83 | 1 | 05.433.04 | BLANKING CAP |
| 84 | 1 | 09.821.05 | DECAL - CUTTING HEAD DANGER |
| 85 | 1 | 09.821.08 | DECAL - SAFE WORKING |
| 86 | 1 | 09.821.04 | DECAL - DANGER THROWN DEBRIS |
| 87 | 1 | 41.217.01 | ADAPTOR |
| 88 | 2 | 8581241 | EXTENSION ADAPTOR |
| 89 | 1 | 8581432 | ADAPTOR - SWIVEL |
| 90 | 4 | 8581331 | ADAPTOR |
| 91 | 1 | 06.418.05 | CLAMP PLATE |
| 92 | 2 | 7193063 | PIPE CLAMP |
| 93 | 1 | 9213165 | BOLT |
| 94 | 1 | 9143005 | SELF-LOCKING NUT |
| 95 | 1 | 8581211 | EXTENSION |
| 96 | 2 | 8650108 | BONDED SEAL |
| 97 | 2 | 42024.07 | PIPE CLAMP |
| 98 | 2 | 9213084 | BOLT |
| 99 | 1 | 09.821.26 | DECAL - ORBIT HEAD |
| 100 | 1 | 7193064 | CLAMP PLATE |
| 101 | 1 | 41996.01 | HOSE KIT - <i>Comprising of:</i> |
| | 2 | 41349.21 | HOSE - 1" BSP FS/F90 x 1100mm |
| | 2 | 10.002.73 | HOSE - 1/4" BSP FS/F90 x 6300mm |
| | 6 | 10.001.20 | HOSE - 1/4" BSP FS/FS x 1000mm |
| | 2 | 10.002.20 | HOSE - 1/4" BSP FS/F90 x 1000mm |
| | 2 | 10.002.15 | HOSE - 1/4" BSP ST/90 x 750mm |
| | 2 | 10.003.86 | HOSE - 3/8" BSP FS/FS x 7600mm |
| | 1 | 10.003.21 | HOSE - 3/8" BSP ST/ST x 1100mm |
| 102 | 1 | 21556.01 | SWITCH BRACKET |
| 103 | 1 | 43177.43 | LOOM - DIVERTER EXTENSION |
| 104 | 1 | 8402208 | SWITCH KIT - LIFT FLOAT |
| 105 | 1 | 43175.02 | COVER PLATE |
| 106 | 1 | 42949.01 | BACK PRESSURE KIT |

BACK PRESSURE VALVE

Module:
42949.01

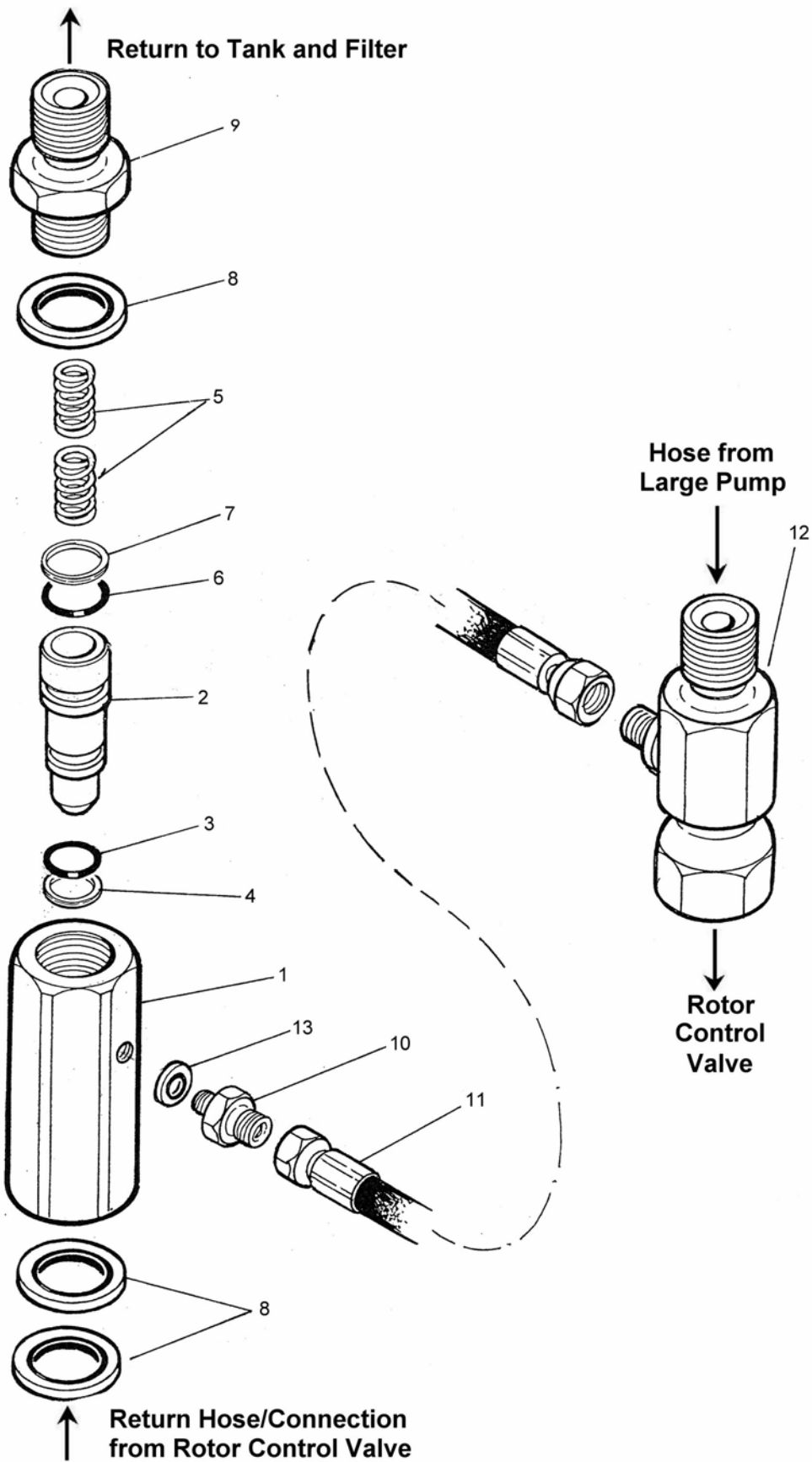



BACK PRESSURE VALVE

| REF. | QTY. | PART No. | DESCRIPTION |
|------|------|-----------------|----------------------------|
| | | 42949.01 | BACK PRESSURE VALVE |
| 1 | 1 | 42949.31 | VALVE BODY |
| 2 | 1 | 42949.32 | PISTON |
| 3 | 1 | 8600402 | O RING |
| 4 | 1 | 8609402 | AE RING |
| 5 | 2 | 8106027 | SPRING |
| 6 | 1 | 8600403 | O RING |
| 7 | 1 | 8609403 | AE RING |
| 8 | 3 | 8650108 | BONDED SEAL |
| 9 | 1 | 42949.33 | SPECIAL ADAPTOR |
| 10 | 1 | 30.052.76 | ADAPTOR |
| 11 | 1 | 10.001.08 | HOSE - 1/4" BSP |
| 12 | 1 | 04.056.33 | TEE |
| 13 | 1 | 05.290.01 | BONDED SEAL |

HYDRAULIC HOSES

| REF. | QTY. | PART NO. | DESCRIPTION |
|------|------|-----------------|--|
| | | 41996.01 | ROTARY DITCHER/CLEANER HOSE KIT |
| 1 | 2 | 41349.21 | HOSE - 1" BSP FS/F90 x 1100mm |
| 2 | 2 | 10.002.73 | HOSE - 1/4" BSP FS/F90 x 6300mm |
| 3 | 6 | 10.001.20 | HOSE - 1/4" BSP FS/FS x 1000mm |
| 4 | 2 | 10.002.20 | HOSE - 1/4" BSP FS/F90 x 1000mm |
| 5 | 2 | 10.002.15 | HOSE - 1/4" BSP FS/F90 x 750mm |
| 6 | 2 | 10.003.86 | HOSE - 3/8" BSP FS/FS x 7600mm |
| 7 | 1 | 10.003.21 | HOSE - 3/8" BSP FS/FS x 1100mm |

- 1 *Motor Drive*
- 2 *Tractor to Diverter Valve (Ports A & B)*
- 3 *Tractor to Diverter Valve Extention (For use as required)*
- 4 *Diverter Valve (Ports E & F) to Orbiter Ram*
- 5 *Diverter Valve (Ports C & D) to Chute Ram*
- 6 *Motor Drain*
- 7 *Motor Drain*

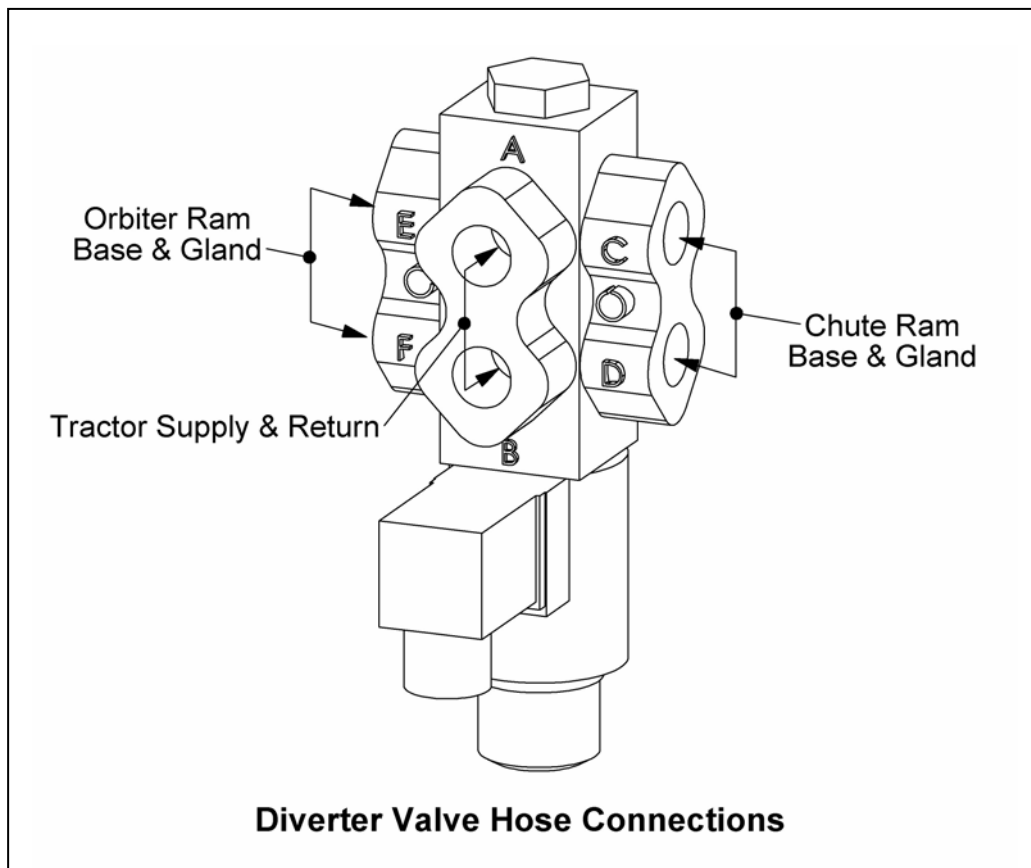

BLADE OPTIONS

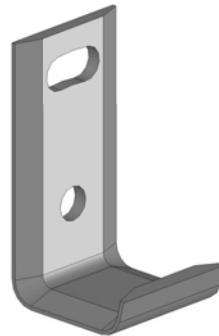

**Double Edged Blade
(Part No. 41.216.01)**

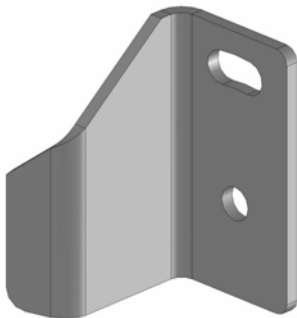

**L/H Standard Duty Single Edged Blade
(Part No. 41936.01)**

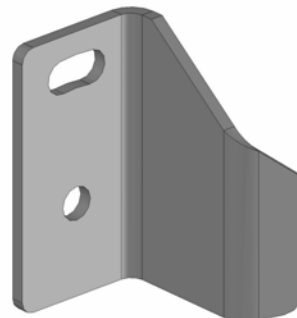

**R/H Standard Duty Single Edged Blade
(Part No. 41936.02)**

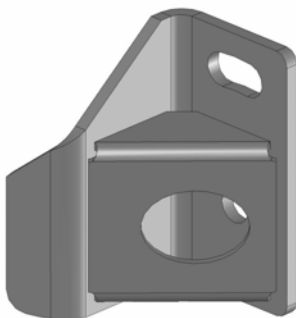

**L/H Heavy Duty Single Edged Blade
(Part No. 41936.03)**

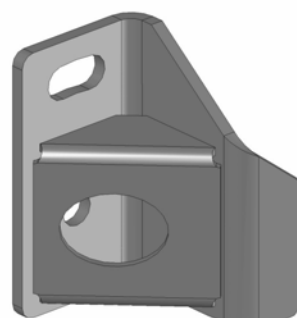

**R/H Heavy Duty Single Edged Blade
(Part No. 41936.04)**



McConnel Limited, Temeside Works, Ludlow, Shropshire SY8 1JL. England.
Telephone: 01584 873131. Facsimile: 01584 876463. www.mcconnel.com