

Publication 1085
September 2024
Part No. 24215.85

MHL150/180/210 CUTTERBARS



Standard Duty

Builds: 650697x, 650698x, 650699x

Operator Manual

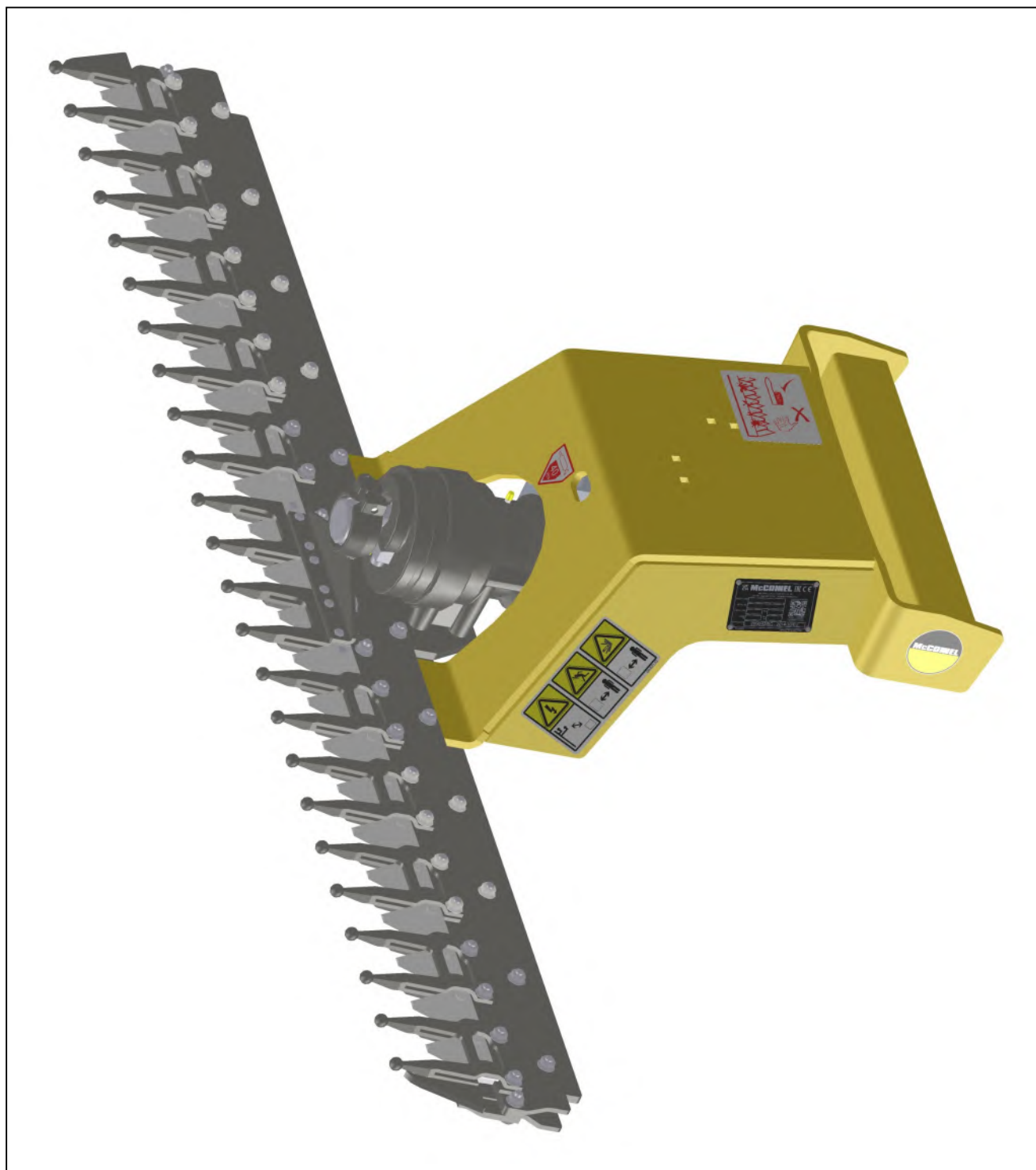

IMPORTANT

VERIFICATION OF WARRANTY REGISTRATION



Dealer Warranty Information & Registration Verification

It is imperative that the selling dealer registers this machine with McConnel Limited before delivery to the end user – failure to do so may affect the validity of the machine warranty.

To register machines; log onto <https://my.mcconnel.com> and select 'Machine Registration' which can be found in the 'Warranty' section of the site. **Confirm to the customer that the machine has been registered by completing the verification form below.**

Registration Verification	Serial No. <input type="text"/>
Dealer Name:	
Dealer Address:	
Customer Name:	
Date of Warranty Registration:/...../..... Dealer Signature:	

Note to Customer / Owner

Please ensure the section above has been completed and signed by the dealer to verify your machine has been registered with McConnel Limited.

IMPORTANT: During the initial 'bedding in' period of a new machine it is the customer's responsibility to regularly inspect all nuts, bolts and hose connections for tightness and re-tighten if required. New hydraulic connections occasionally weep small amounts of oil as the seals and joints settle in – where this occurs it can be cured by re-tightening the connection – *refer to torque settings chart below*. The tasks stated above should be performed on an hourly basis during the first day of work and at least daily thereafter as part of the machine's general maintenance procedure.

CAUTION: DO NOT OVER TORQUE HYDRAULIC FITTINGS AND HOSES

Torque Settings for Hydraulic Fittings

Hydraulic Hose Ends		
BSP	Setting	Metric
1/4"	18 Nm	19 mm
3/8"	31 Nm	22 mm
1/2"	49 Nm	27 mm
5/8"	60 Nm	30 mm
3/4"	80 Nm	32 mm
1"	125 Nm	41 mm
1.1/4"	190 Nm	50 mm
1.1/2"	250 Nm	55 mm
2"	420 Nm	70 mm

Port Adaptors with Bonded Seals		
BSP	Setting	Metric
1/4"	34 Nm	19 mm
3/8"	47 Nm	22 mm
1/2"	102 Nm	27 mm
5/8"	122 Nm	30 mm
3/4"	149 Nm	32 mm
1"	203 Nm	41 mm
1.1/4"	305 Nm	50 mm
1.1/2"	305 Nm	55 mm
2"	400 Nm	70 mm

WARRANTY POLICY

WARRANTY REGISTRATION

All machines must be registered, by the selling dealer with McConnel Ltd, before delivery to the end user. On receipt of the goods it is the buyer's responsibility to check that the Verification of Warranty Registration in the Operator's Manual has been completed by the selling dealer.

1. LIMITED WARRANTIES

- 1.01. *All mounted machines supplied by McConnel Ltd are warranted to be free from defects in material and workmanship from the date of sale to the original purchaser for a period of 12 months, unless a different period is specified.
All Self Propelled Machines supplied by McConnel Ltd are warranted to be free from defects in material and workmanship from the date of sale to the original purchaser for a period of 12 months or 1500 hours. Engine warranty will be specific to the Manufacturer of that unit.*
- 1.02. *All spare parts supplied by McConnel Ltd and purchased by the end user are warranted to be free from defects in material and workmanship from the date of sale to the original purchaser for a period of 6 months. All parts warranty claims must be supported by a copy of the failed part invoice to the end user. We cannot consider claims for which sales invoices are not available.*
- 1.03. *The warranty offered by McConnel Ltd is limited to the making good by repair or replacement for the purchaser any part or parts found, upon examination at its factory, to be defective under normal use and service due to defects in material or workmanship. Returned parts must be complete and unexamined. Pack the component(s) carefully so that any transit damage is avoided. All ports on hydraulic items should be drained of oil and securely plugged to prevent seepage and foreign body ingress. Certain other components, electrical items for example, may require particular care when packing to avoid damage in transit.*
- 1.04. *This warranty does not extend to any product from which McConnel Ltd's serial number plate has been removed or altered.*
- 1.05. *The warranty policy is valid for machines registered in line with the terms and conditions detailed and on the basis that the machines do not extend a period of 24 months or greater since their original purchase date, that is the original invoice date from McConnel Limited.
Machines that are held in stock for more than 24 months cannot be registered for warranty.*
- 1.06. *This warranty does not apply to any part of the goods, which has been subjected to improper or abnormal use, negligence, alteration, modification, fitment of non-genuine parts, accident damage, or damage resulting from contact with overhead power lines, damage caused by foreign objects (e.g. stones, iron, material other than vegetation), failure due to lack of maintenance, use of incorrect oil or lubricants, contamination of the oil, or which has served its normal life. This warranty does not apply to any expendable items such as blades, belts, clutch linings, filter elements, flails, flap kits, skids, soil engaging parts, shields, guards, wear pads, pneumatic tyres or tracks.*
- 1.07. *Temporary repairs and consequential loss - i.e. oil, downtime and associated parts are specifically excluded from the warranty.*
- 1.08. *Warranty on hoses is limited to 12 months and does not include hoses which have suffered external damage. Only complete hoses may be returned under warranty, any which have been cut or repaired will be rejected.*
- 1.09. *Machines must be repaired immediately a problem arises. Continued use of the machine after a problem has occurred can result in further component failures, for which McConnel Ltd cannot be held liable, and may have safety implications.*
- 1.10. *If in exceptional circumstances a non McConnel Ltd part is used to effect a repair, warranty reimbursement will be at no more than McConnel Ltd's standard dealer cost for the genuine part.*

- 1.11. *Except as provided herein, no employee, agent, dealer or other person is authorised to give any warranties of any nature on behalf of McConnell Ltd.*
- 1.12. *For machine warranty periods in excess of 12 months the following additional exclusions shall apply:*
 - 1.12.1. *Hoses, exposed pipes and hydraulic tank breathers.*
 - 1.12.2. *Filters.*
 - 1.12.3. *Rubber mountings.*
 - 1.12.4. *External electric wiring.*
 - 1.12.5. *Bearings and seals*
 - 1.12.6. *External Cables, Linkages*
 - 1.12.7. *Loose/Corroded Connections, Light Units, LED's*
 - 1.12.8. *Comfort items such as Operator Seat, Ventilation, Audio Equipment*
- 1.13. *All service work, particularly filter changes, must be carried out in accordance with the manufacturer's service schedule. Failure to comply will invalidate the warranty. In the event of a claim, proof of the service work being carried out may be required.*
- 1.14. *Repeat or additional repairs resulting from incorrect diagnosis or poor quality previous repair work are excluded from warranty.*

NB Warranty cover will be invalid if any non-genuine parts have been fitted or used. Use of non-genuine parts may seriously affect the machine's performance and safety. McConnell Ltd cannot be held responsible for any failures or safety implications that arise due to the use of non-genuine parts.

2. REMEDIES AND PROCEDURES

- 2.01. *The warranty is not effective unless the Selling Dealer registers the machine, via the McConnell web site and confirms the registration to the purchaser by completing the confirmation form in the operator's manual.*
- 2.02. *Any fault must be reported to an authorised McConnell Ltd dealer as soon as it occurs. Continued use of a machine, after a fault has occurred, can result in further component failure for which McConnell Ltd cannot be held liable.*
- 2.03. *Repairs should be undertaken within two days of the failure. Claims submitted for repairs undertaken more than 2 weeks after a failure has occurred, or 2 days after the parts were supplied will be rejected, unless the delay has been authorised by McConnell Ltd. Please note that failure by the customer to release the machine for repair will not be accepted as a reason for delay in repair or submitting warranty claims.*
- 2.04. *All claims must be submitted, by an authorised McConnell Ltd Service Dealer, within 30 days of the date of repair.*
- 2.05. *Following examination of the claim and parts, McConnell Ltd will pay, at their discretion, for any valid claim the invoiced cost of any parts supplied by McConnell Ltd and appropriate labour and mileage allowances if applicable.*
- 2.06. *The submission of a claim is not a guarantee of payment.*
- 2.07. *Any decision reached by McConnell Ltd. is final.*

3. LIMITATION OF LIABILITY

- 3.01. *McConnell Ltd disclaims any express (except as set forth herein) and implied warranties with respect to the goods including, but not limited to, merchantability and fitness for a particular purpose.*
- 3.02. *McConnell Ltd makes no warranty as to the design, capability, capacity or suitability for use of the goods.*
- 3.03. *Except as provided herein, McConnell Ltd shall have no liability or responsibility to the purchaser or any other person or entity with respect to any liability, loss, or damage caused or alleged to be caused directly or indirectly by the goods including, but not limited to, any indirect, special, consequential, or incidental damages resulting from the use or operation of the goods or any breach of this warranty. Notwithstanding the above limitations and warranties, the manufacturer's liability hereunder for damages incurred by the purchaser or others shall not exceed the price of the goods.*
- 3.04. *No action arising out of any claimed breach of this warranty or transactions under this warranty may be brought more than one (1) year after the cause of the action has occurred.*

4. MISCELLANEOUS

- 4.01. *McConnel Ltd may waive compliance with any of the terms of this limited warranty, but no waiver of any terms shall be deemed to be a waiver of any other term.*
- 4.02. *If any provision of this limited warranty shall violate any applicable law and is held to be unenforceable, then the invalidity of such provision shall not invalidate any other provisions herein.*
- 4.03. *Applicable law may provide rights and benefits to the purchaser in addition to those provided herein.*

McConnel Limited



For Safety and Performance...

ALWAYS READ THE BOOK FIRST

McCONEL LIMITED

**Temeside Works
Ludlow
Shropshire
England**

**Telephone: +44 (0)1584 873131
www.mcconel.com**

- NOISE STATEMENT -

The equivalent daily personal noise exposure from this machine measured at the operators' ear is within the range 78 – 85 dB, these figures apply to a normal distribution of use where the noise fluctuates between zero and maximum. The figures assume that the machine is fitted to a tractor with a 'quiet' cab with the windows closed in a generally open environment. We recommend that the windows are kept closed. With the cab rear window open the equivalent daily personal noise exposure will increase to a figure within the range 82 – 88 dB. At an equivalent daily noise exposure level of 85 – 90 dB ear protection is recommended and must always be used if any window is left open.



Operating, servicing and maintaining this equipment can expose you to chemicals including gasoline, diesel fuel, lubricants, petroleum products, engine exhaust, carbon monoxide, and phthalates, which are known to the State of California to cause cancer and birth defects or other reproductive harm. To minimize exposure, avoid breathing exhaust, do not idle the engine except as necessary, service your vehicle in a well-ventilated area and wear gloves or wash your hands frequently when servicing your vehicle. Battery posts, terminals and related accessories contain lead and lead compounds, chemicals known to the state of California to cause cancer, birth defects or other reproductive harm. For more information go to www.P65Warnings.ca.gov. This website, operated by California's Office of Environmental Health Hazard Assessment, provides information about these chemicals and how individuals may be exposed to them.

CONTENTS

General Information	1
Machine Description & Purpose of Use	3
Technical Specifications	3
Component Identification	4
Safety Information	5
Safety Decals	9
Vehicle Preparation	10
Procedure for Use	11
Installation	11
Start Up & Operation	12
Working	12
Transportation of the Machine	12
Machine Removal	12
Storage	12
Overhead Power Line Dangers	13
Maintenance	15
Troubleshooting	30

GENERAL INFORMATION

Read this manual before fitting or operating the machine or accessory. Whenever any doubt exists contact your local dealer or the McConnel Service Department for assistance.

Only use 'Genuine McConnel Parts' on McConnel machinery and equipment.

DEFINITIONS: *The following definitions apply throughout this manual;*

⚠ DANGER

DANGER: *Alerts to a hazardous situation which will result in death or serious injury if not observed carefully.*

⚠ WARNING

WARNING: *Alerts to a hazardous situation which could result in death or serious injury if not observed carefully.*

⚠ CAUTION

CAUTION: *Alerts to a hazardous situation which could result in damage to the machine and/or equipment if not observed carefully.*

NOTICE

NOTICE: *Specific or general information considered important or useful to emphasise.*

LEFT HAND (LH) & RIGHT HAND (RH): *These terms are applicable to the machine when fitted to the tractor and viewed from the rear; these terms also apply to tractor references.*

SERIAL PLATE

All machines are equipped with a serial number plate containing important information relating to the machine including a unique serial number used for identification purposes.

Note: Images in this manual are provided for instruction and informational purposes only and may not show components in their entirety. In certain instances images may appear different to the actual machine; where this occurs the general procedure will be basically the same. E&OE.

MACHINE & DEALER INFORMATION

Record the serial number of your machine on this page and always quote it when ordering parts. Whenever information concerning the machine is requested remember to also state the make and model of tractor to which the machine is fitted.	
Machine Serial Number:	Installation Date:
Machine Model Details:	
Dealer Name & Branch:	
Dealer Address:	
Dealer Telephone No:	
Dealer Email Address:	

MACHINE DESCRIPTION & PURPOSE OF USE

The McConnel MHL150, MHL180 & MHL210 are a range of 'Power Arm' mounted hydraulic Cutterbars for performing hedge trimming duties. Cutterbars are available in 1.5m, 1.8m and 2.1m working widths and are suitable for cutting hedge materials up to a maximum branch thickness of 30mm under normal conditions.

These machines should only be used to perform tasks for which they were designed; use of the machines for any other function is dangerous to persons and risks damaging machine and/or components.

Handling

Handling of this machine, as with all machinery, should only be performed using suitable lifting equipment operated by persons fully trained in its safe use.

Hoisting

Before hoisting the machines ensure that the hoisting equipment is suitable for lifting the weight of the machine and that the working area has been inspected to detect the presence of possible dangers such as electric power lines, gas or fluid lines etc. Ensure that there is sufficient space and headroom for safe manoeuvring and all bystanders are kept at a safe distance at all times. Ensure that the unit is correctly balanced before attempting to raise the machine.

⚠ DANGER Failure to follow the above instructions may result in injury to persons and/or damage to the machinery.

TECHNICAL SPECIFICATIONS

Specifications	MHL150	MHL180	MHL210
Working Width	150cm	180cm	210cm
Cutting Thickness (Max.)	30mm	30mm	30mm
Rotational Speed	Max. 400 rpm	Max. 400 rpm	Max. 400 rpm
Work Rate (Max.)	5 km/h	5 km/h	5 km/h
Width	155cm	186cm	216cm
Height	20cm	20cm	20cm
Depth	50cm	50cm	50cm
Weight	65 kg	73 kg	80 kg
Permanent Pressure	Max. 175 bar	Max. 175 bar	Max. 175 bar
Oil Quantity	20-40 l/min	20-40 l/min	20-40 l/min
No. Knives	19	23	27

MACHINE IDENTIFICATION

Serial Plate

Each machine is fitted with an identification plate which includes the following information:

1. Model/Code (Part Number)
2. Machine Serial No.
3. Machine Weight

When ordering spares or replacement parts from your local dealer it is important to quote the part number and serial number as stated on the identification plate so machine and model can be quickly and correctly identified.

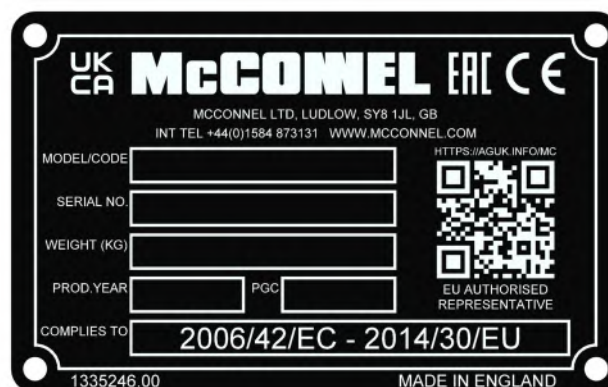

COMPONENT IDENTIFICATION

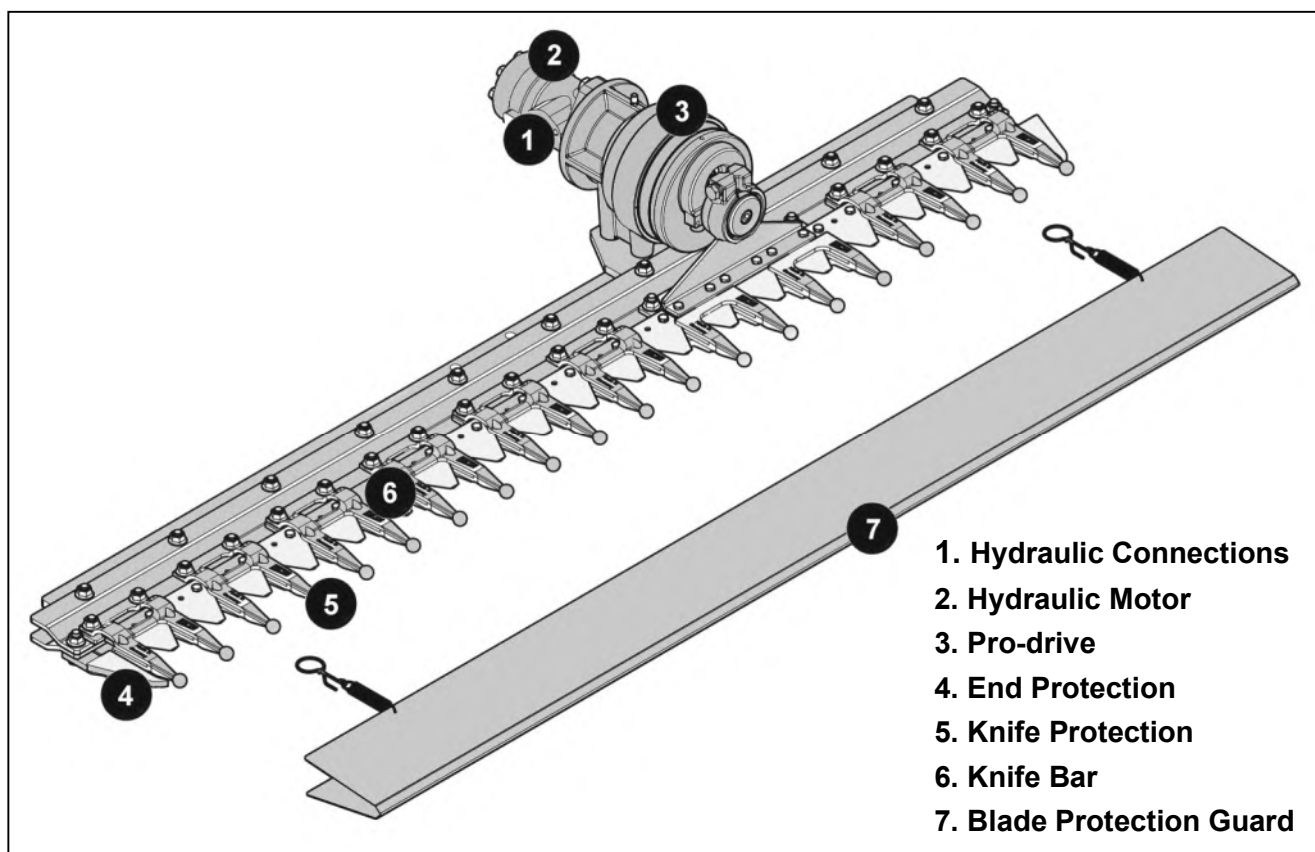

Overview

The hedge trimmer consists of a profiled, stationary bar equipped with knife protection guards. These guards contain the knife that is driven by the Pro-drive (planetary drive) and a hydraulic motor.

The hedge trimmer is attached to the carrier vehicle or implement carrier by means of a mechanical and hydraulic connection.

The blade protection guard is fitted to the hedge trimmer by means of tension springs.



Read safety information for all machinery you are operating

This machine has the potential to be extremely dangerous - in the wrong hands it can kill or maim; It is therefore imperative that both owner and operator of the machine reads and understands the following section to ensure they are fully aware of the dangers that do, or may exist, and their responsibilities surrounding the use and operation of the machine.

The operator of this machine is responsible not only for their own safety but equally for the safety of others who may come into the close proximity of the machine, as the owner you are responsible for both.

When the machine is not in use it should be lowered to rest on the ground. In the event of any fault being detected with the machine's operation it must be stopped immediately and not used again until the fault has been corrected by a qualified technician.

POTENTIAL DANGERS ASSOCIATED WITH THE USE OF THIS MACHINE:

- ▲ *Being hit by debris thrown by moving components.*
- ▲ *Being hit by machine parts ejected through damage during use.*
- ▲ *Being caught on a rotating power take-off (PTO) shaft.*
- ▲ *Being caught in other moving parts i.e.: belts, pulleys and cutting heads.*
- ▲ *Electrocution from Overhead Power Lines (by contact with or 'flashover' from).*
- ▲ *Being hit by cutting heads or machine arms as they move.*
- ▲ *Becoming trapped between tractor and machine when hitching or unhitching.*
- ▲ *Tractor overbalancing when machine arm is extended.*
- ▲ *Injection of high-pressure oil from hydraulic hoses or couplings.*
- ▲ *Machine overbalancing when freestanding (out of use).*
- ▲ *Road traffic accidents due to collision or debris on the road.*

BEFORE USING THIS MACHINE YOU MUST:

- ▲ *Ensure you read all sections of the operator handbook for this machine and any other machines associated to its use.*
- ▲ *Ensure the operator is, or has been, properly trained to use the machine.*
- ▲ *Ensure the operator has been issued with and reads the operator handbook.*
- ▲ *Ensure the operator understands and follows the instructions in operator handbook.*
- ▲ *Ensure the tractor front, rear and sides are fitted with metal mesh or polycarbonate guards of suitable size and strength to protect the operator against thrown debris or parts.*
- ▲ *Ensure tractor guards are fitted correctly, are undamaged and kept properly maintained.*
- ▲ *Ensure that all machine guards are in position, are undamaged, and are kept maintained in accordance with the manufacturer's recommendations.*
- ▲ *Ensure knives and their fixings are of a type recommended by the manufacturer, are securely attached and that none are missing or damaged.*
- ▲ *Ensure hydraulic pipes are carefully and correctly routed to avoid damage by chaffing, stretching or pinching and that they are held in place with the correct fittings.*
- ▲ *Always follow the manufacturer's instructions for attachment and removal of the machine.*
- ▲ *Check that the machine fittings and couplings are in good condition.*
- ▲ *Ensure the tractor meets the minimum weight recommendations of the machine's manufacturer and that ballast is used as necessary.*
- ▲ *Always inspect the work area thoroughly before starting to note obstacles and remove wire, bottles, cans and other debris.*
- ▲ *Use clear suitably sized warning signs to alert others to the nature of the machine working within that area. Signs should be placed at both ends of the work site. (It is recommended that signs used are of a size and type specified by the Department of Transport and positioned in accordance with their, and the Local Highways Authority, guidelines).*
- ▲ *Ensure the operator is protected from noise. Ear defenders should be worn and tractor cab doors and windows must be kept closed. Machine controls should be routed through proprietary openings in the cab to enable all windows to be shut fully.*
- ▲ *Always work at a safe speed taking account of the conditions i.e.: terrain, highway proximity and obstacles around and above the machine. Extra special attention should be applied to Overhead Power Lines. Some of our machines are capable of reach in excess of 8 metres (26 feet) this means they have the potential to well exceed, by possibly 3 metres (9' 9"), the lowest legal minimum height of 5.2 metres from the ground for 11,000 and 33,000 volt power lines. It cannot be stressed enough the dangers that surround this capability, it is therefore vital that the operator is fully aware of the maximum height and reach of the machine, and that they are fully conversant with all aspects regarding the safe minimum distances that apply when working with machines in close proximity to Power Lines. (Further information on this subject can be obtained from the Health & Safety Executive or your Local Power Company).*

- ▲ *Always disengage the machine, kill the tractor engine, remove and pocket the key before dismounting for any reason.*
- ▲ *Always clear up all debris left at the work area, it may cause hazard to others.*
- ▲ *Always ensure when you remove your machine from the tractor that it is left in a safe and stable position and secured if necessary.*

WHEN NOT TO USE THIS MACHINE:

- ▲ *Never attempt to use this machine if you have not been trained to do so.*
- ▲ *Never use a machine until you have read and understood the operator handbook, are familiar with it, and practiced the controls.*
- ▲ *Never use a machine that is poorly maintained.*
- ▲ *Never use a machine if guards are missing or damaged.*
- ▲ *Never use a machine on which the hydraulic system shows signs of wear or damage.*
- ▲ *Never fit, or use, a machine on a tractor that does not meet the manufacturer's minimum specification level.*
- ▲ *Never use a machine fitted to a tractor that does not have suitable front, rear and side(s) cab guarding made of metal mesh or polycarbonate.*
- ▲ *Never use the machine if the tractor cab guarding is damaged, deteriorating or badly fitted.*
- ▲ *Never turn a machine cutting head to an angle that causes debris to be ejected towards the cab.*
- ▲ *Never start or continue to work a machine if people are nearby or approaching - Stop and wait until they are at a safe distance before continuing. WARNING: Some cutting heads may continue to 'freewheel' for up to 40 seconds after being stopped.*
- ▲ *Never attempt to use a machine on materials in excess of its capability.*
- ▲ *Never use a machine to perform a task it has not been designed to do.*
- ▲ *Never operate the tractor or machine controls from any position other than from the driving seat, especially whilst hitching or unhitching the machine.*
- ▲ *Never carry out maintenance of a machine or a tractor whilst the engine is running – the engine should be switched off, the key removed and pocketed.*
- ▲ *Never leave a machine unattended in a raised position – it should be lowered to the ground in a safe position on a level firm site.*
- ▲ *Never leave a tractor with the key in or the engine running.*
- ▲ *Never carry out maintenance on any part or component of a machine that is raised unless that part or component has been properly substantially braced or supported.*
- ▲ *Never attempt to detect a hydraulic leak with your hand – use a piece of cardboard.*
- ▲ *Never allow children near to, or play on, a tractor or machine under any circumstances.*

ADDITIONAL SAFETY ADVICE

Training

Operators need to be competent and fully capable of operating this machine in a safe and efficient way prior to attempting to use it in any public place. We advise therefore that the prospective operator make use of relevant training courses available such as those run by the Agricultural Training Board, Agricultural Colleges, Dealers and McConnell.

Working in Public Places

When working in public places such as roadsides, consideration should be paid to others in the vicinity. Stop the machine immediately when pedestrians, cyclists and horse riders etc. pass. Restart only when they are at a distance that causes no risk to their safety.

Warning Signs

It is advisable that any working area be covered by suitable warning signs and statutory in public places. Signs should be highly visible and well placed in order to give clear advanced warning of the hazard. Contact the Department of Transport or your Local Highways Authority to obtain detailed information on this subject. The latter should be contacted prior to working on the public highway advising them of the time and location of the intended work asking what is required by way of signs and procedure. – *‘Non-authorized placement of road signs may create offences under the Highways Act’.*

Suggested Warning Signs Required

‘Road works ahead’ warning sign with a supplementary ‘Hedge cutting’ plate. ‘For 1 mile’ or appropriate shorter distance may be added to the plate.

‘Road narrows’ warning signs with supplementary ‘Single file traffic’ plate.

White on blue ‘Keep right’ () arrow sign on rear of machine.*

** Note – this applies to UK Market machines where traffic passes to the right of a machine working in the same direction as the traffic flow. The direction, use and colour of the arrow sign will depend on the country of use and the Local Highway Authorities regulations in the locality.*

Use of Warning Signs

- ▲ *On two-way roads one set of signs is needed facing traffic in each direction.*
- ▲ *Work should be within 1 mile of the signs.*
- ▲ *Work only when visibility is good and at times of low risk e.g.: NOT during ‘rush-hour’.*
- ▲ *Vehicles should have an amber-flashing beacon.*
- ▲ *Ideally, vehicles should be conspicuously coloured.*
- ▲ *Debris should be removed from the road and path as soon as practicable, and at regular intervals, wearing high visibility clothing and before removing the hazard warning signs.*
- ▲ *Collect all road signs promptly when the job is completed.*

Although the information stated here covers a wide range of safety subjects it is impossible to predict every eventuality that can occur under differing circumstances whilst operating this machine. No advice given here can replace ‘good common sense’ and ‘total awareness’ at all times, but will go a long way towards the safe use of your McConnell machine.

SAFETY DECALS

Safety Information Decals - Identification

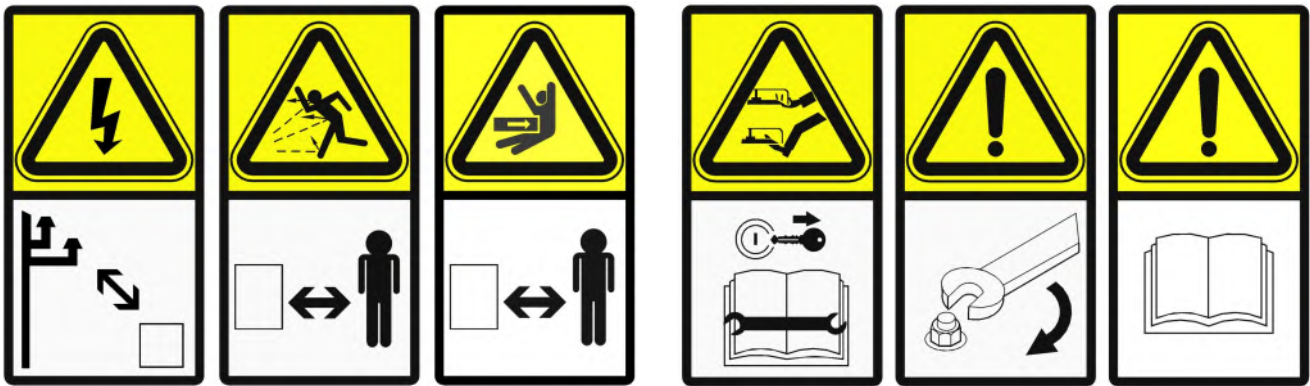

1.

2.

3.

4.

5.

6.

1. DANGER Overhead Power Lines

Keep machinery clear of power lines

2. DANGER Thrown Objects Risk

Keep all persons clear of the working machine

3. DANGER Crush Hazard

Keep all persons clear of the machinery

4. DANGER Keep Clear of Machine

Switch OFF and remove key before accessing

5. WARNING Keep bolts tight

Check tightness of fixings before machine use

6. WARNING Read the Manual

Read manual before operating or maintaining

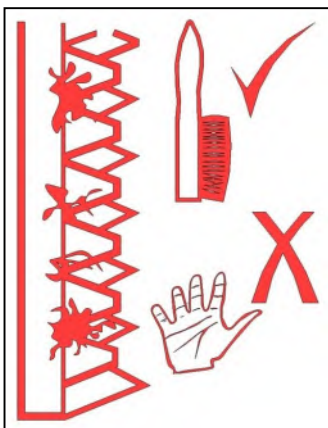

7.

7. DANGER Keep Finger Clear

Use brush or suitable tools to clear debris



8.

8. GREASE DECAL

Grease every 40 HOURS

⚠ WARNING

Ensure these Safety Warning Decals are present on the machine at all times and are kept in a clean legible condition. If any of the Safety Decals are damaged, missing or otherwise illegible they must be replaced immediately.

⚠ WARNING

Shut down the machine and remove the ignition key for all assembly, maintenance and repair work. Wait until all components have come to a complete standstill before approaching the machine.

Safety Gear: It is recommended that the following personal protective equipment is worn when operating and/or maintaining this machine; Coveralls, safety boots, safety glasses, hearing protection, safety helmet, protective gloves, and protective dust mask.



VEHICLE / TRACTOR PREPARATION

We recommend vehicles are fitted with cabs using 'safety glass' windows and protective guarding when used with our machines.

Fit Operator Guard (Part No. 7313324) using the hooks provided. Shape the mesh to cover all vulnerable areas. The driver must be looking through mesh and/or polycarbonate glazing when viewing the flail head in any working position - unless the vehicle/ cab

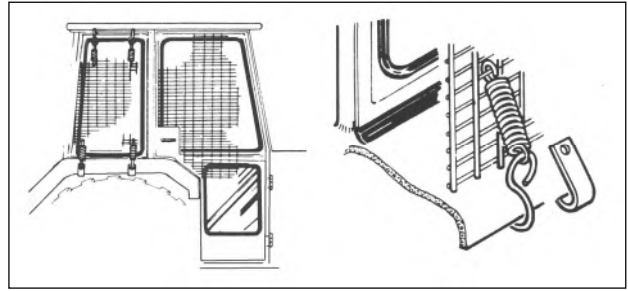

manufacturer can demonstrate that the penetration resistance is equivalent to, or higher than, that provided by mesh/polycarbonate glazing. If the tractor has a roll bar only, a frame must be made to carry both mesh and polycarbonate glazing. The operator should also use personal protective equipment to reduce the risk of serious injury such as; eye protection (mesh visor to EN1731 or safety glasses to EN166), hearing protection to EN352, safety helmet to EN297, gloves, filter mask and high visibility clothing.

Vehicle Ballast: It is imperative when attaching 'third-party' equipment to a vehicle that the maximum possible stability of the machine and vehicle combination is achieved – this can be accomplished by the utilisation of 'ballast' in order to counter-balance the additional equipment added.

Front weights may be required for rear mounted machines to place 15% of total outfit weight on the front axle for stable transport on the road and to reduce 'crabbing' due to the drag of the cutting unit when working on the ground.

Rear weights may be required to maintain a reasonable amount of rear axle load on the opposite wheel from the arms when in work; for normal off-ground work i.e. hedge cutting this should be 20% of rear axle weight or more for adequate control, and for ground work i.e. verge mowing with experienced operators, this can be reduced to 10%.

All factors must be addressed in order to match the type and nature of the equipment added to the circumstances under which it will be used – in the instance of Power Arm hedgecutters it must be remembered that the machines centre of gravity during work will be constantly moving and will differ from that during transport mode, therefore balance becomes critical.

Factors that effect stability:

- Centre of gravity of the tractor/machine combination.
- Geometric conditions, e.g. position of the cutting head and ballast.
- Weight, track width and wheelbase of the tractor.
- Acceleration, braking, turning and the relative position of the cutting head during these operations.
- Ground conditions, e.g. slope, grip, load capability of the soil/surface.
- Rigidity of implement mounting.

Suggestions to increase stability:

- Increasing rear wheel track; a vehicle with a wider wheel track is more stable.
- Ballasting the wheel; it is preferable to use external weights but liquid can be added to around 75% of the tyre volume – water with anti-freeze or the heavier Calcium Chloride alternative can be used.
- Addition of weights – care should be taken in selecting the location of the weights to ensure they are added to a position that offers the greatest advantage.
- Front axle locking (check with tractor manufacturer).

NOTE: The advice above is offered as a guide for stability only and is not a guide to vehicle strength. It is recommended that you consult your vehicle manufacturer or local dealer to obtain specific advice on this subject, additionally advice should be sought from a tyre specialist with regard to tyre pressures and ratings suitable for the type and nature of the machine you intend to fit.

PROCEDURE FOR USE

⚠ CAUTION This machine should only be used for the trimming of hedges, reeds or young growth materials up to a maximum diameter of 30mm.

For safety purposes the machine is supplied with a blade protection guard that attaches over the knives of the cutterbar and is held in place with spring clips; the guard should be fitted to cutterbar at all times other than during work and must always be fitted during installation and transport.

INSTALLATION

Before beginning installation ensure that the specifications of the 'vehicle' machine match those of the cutterbar and that the connecting pipes are suitable to sustain the maximum working pressure. The working environment and all connections and fittings should be kept clean in order to protect the hydraulic system from contamination by grit or dirt.

The attachment procedure should be performed on a clean firm level site with suitable space to manoeuvre tractor and machine adjacent to the cutterbar.

The blade protection guard must be fitted during installation, transportation and storage.

⚠ WARNING Ensure all persons are kept clear of machine and tractor when positioning the machine for attachment.

Attaching

Place the hydraulic arm of the 'vehicle' machine into a position that will allow attachment of the cutterbar; fit and secure the cutterbar in place using the mounting kit supplied.

Ensure hydraulic hoses are routed where they are not at risk of being trapped, stretched or otherwise damaged during normal arm movements when operating the machinery.

Hydraulic Connections

Connect the pressure and return hoses to the cutterbar motor; the hoses can be plumbed either way round as the motor is designed to operate in either direction.

Blade Protection Guard

The blade protector guard must be removed prior to start up with the motor switched off and the oil not under pressure, and replaced only once the machine has stopped completely – *the protector should be in position at all times during transportation and storage as a means of safeguarding people and machine.*

⚠ CAUTION Do not attempt to run the machine with the blade protection guard fitted. Remove protection guard before starting the cutterbar.

⚠ WARNING Removal of the blade protection guard must only be performed when the motor is switched off and the oil free from pressure.

START UP AND OPERATION

Start up and operation of the cutterbar must only be carried out by an operator who has been fully trained in the use of such machinery and is fully aware of the dangers and hazards surrounding the use of this type of machine.

Ensure all persons remain at a safe distance before starting the machine and at all times whilst it is running.

⚠ WARNING Never approach the cutterbar whilst it is running or working.

On initial startup of the machine keep the speed to a minimum for several minutes after which time the machine can then put through some light movement to check all functions operate correctly.

On new machines the tightness of all nuts and bolts, connectors, pipes and clamps should be checked on an hourly basis during the first day of work, and where necessary retightened. On subsequent days' work, the same procedure should be carried out at regular intervals and always prior to starting work each day.

WORKING

This machine must only be operated by persons who are fully trained and familiar with machinery of this type. The work area should be thoroughly inspected prior to starting in order to detect and note possible dangers or hazards – removable objects that may cause problems such as wire, glass, bricks or large stones etc. should be cleared from the work area beforehand and any immovable hazards should be clearly marked in order to avoid them.

The cutterbar must only be used for cutting materials for which it is designed – hedges, shrubs and wood plant materials up to maximum of 30mm diameter – failure to observe this may cause injury to persons and/or damage to the machine.

In addition to the information stated in this manual, operators must read the operation manuals for the tractor and machine that the cutterbar is being operated on.

⚠ WARNING Keep all persons and animals at a safe distance from the machine whilst working – if passers-by approach all work should be halted until they are clear of the danger area.

TRANSPORTATION OF THE MACHINE

For transportation the machine and cutterbar should be positioned within the width of the carrying vehicle with the blade protection guard fitted and machine controls positioned or protected against accidental or inadvertent operation during transport. Warning lights and/or signs should be displayed as and where required or if local highway authority rules dictate.

MACHINE REMOVAL

Turn off the motor and ensure that the hydraulic oil is not under pressure before removing the pipes connected to the cutterbar motor. Cap all hydraulic connection points and hoses to protect the hydraulic system from risk of dirt and moisture contamination.

Block and suitably support the cutterbar before removing it from the 'vehicle' machine. Removal is basically a reversal of the attachment procedure. Blade protection guard must be fitted for the removal procedure and during transport and storage.

STORAGE

Transport the unattached cutterbar using suitable means and store on a level, safe, clean and dry environment where it will not cause hazard or danger to persons or animals.

Thoroughly clean and lubricate the machine prior to storage and ensure blade protection guard is securely fitted.

OVERHEAD POWER LINES (OHPLs)

It cannot be stressed enough the dangers involved when working in the vicinity of Overhead Power Lines (OHPLs). Some of our machines are capable of reach in excess of 8 metres (26'); they have the potential to well exceed, by possibly 3 metres (9' 9"), the lowest legal minimum height of 5.2 metres from the ground for 11,000 and 33,000 volt power lines. Remember electrocution can occur without actually coming into contact with a power line as electricity can 'flashover' when machinery gets close to it.

⚠ WARNING All operators must read the following information and be aware of the risks and dangers involved when working in the vicinity of Overhead Power Lines (OHPLs).

Wherever possible the safest option is always to avoid working in areas close to OHPLs. Where unavoidable, all operators must perform a risk assessment and implement a safe procedure and system of work – see *following page for details*. All operators should perform a risk assessment before operating the machine within 10m horizontal distance of any OHPLs.

Minimum Heights for Overhead Power Lines

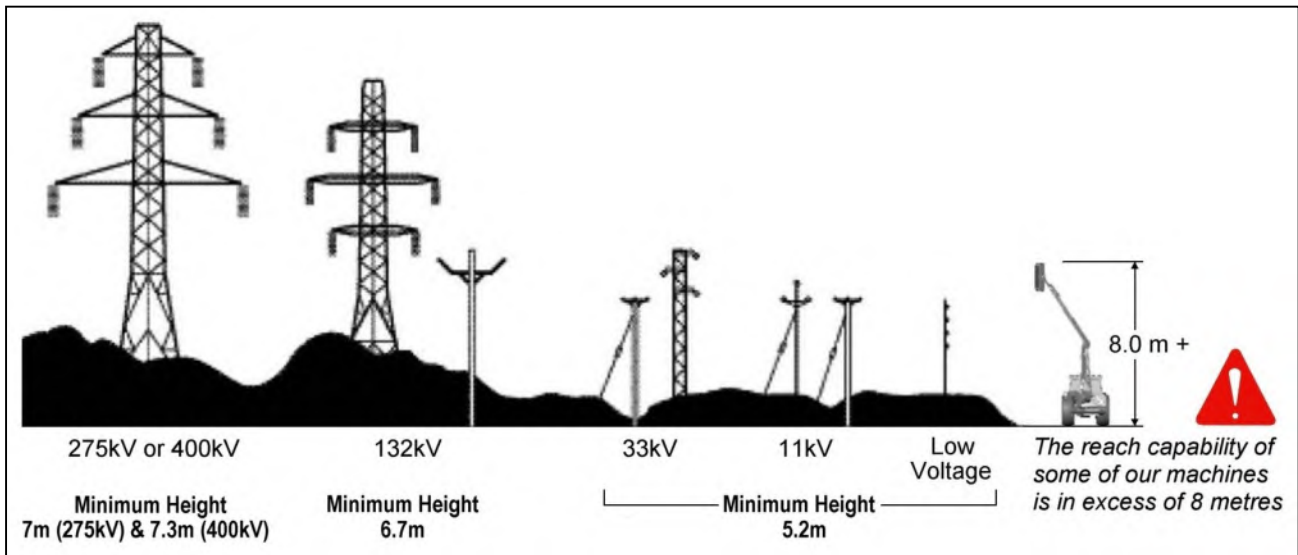

Absolute Minimum Exclusion Zones for Specific Overhead Power Lines

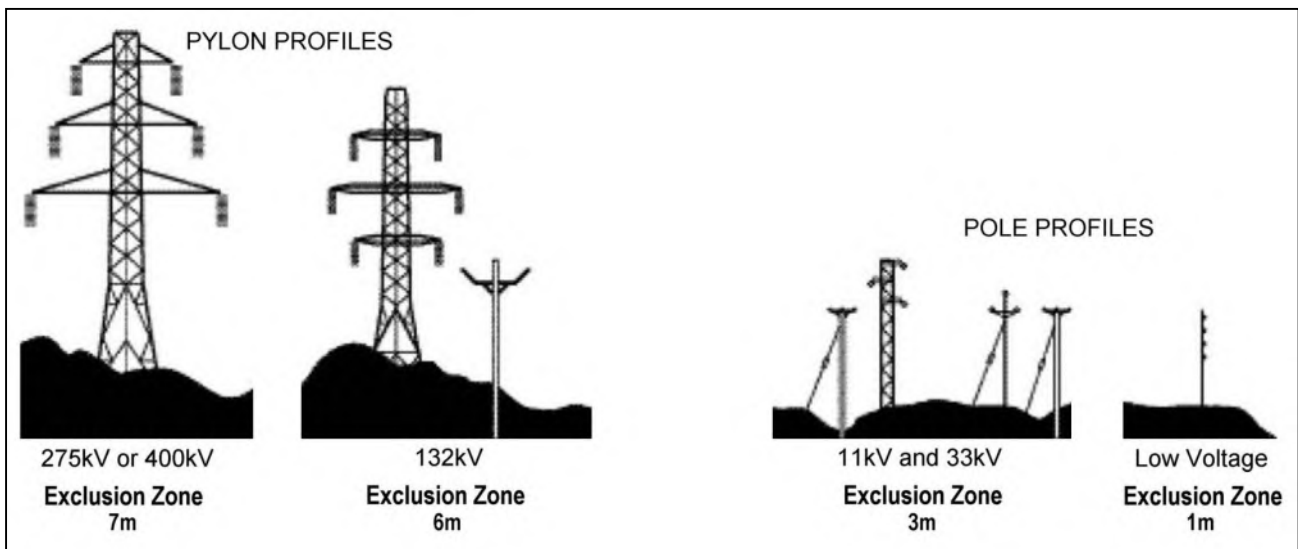

Definitions of Exclusion Zones

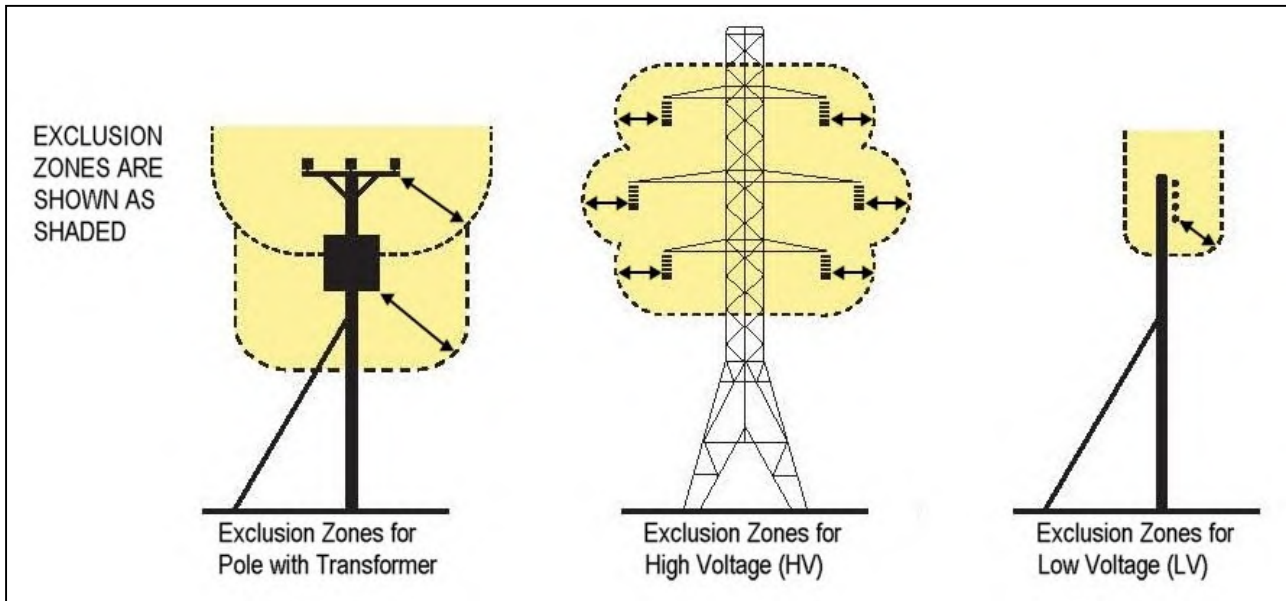

Risk Assessment

Before starting to work near OHPLs you should always assess the risks. The following points should be observed;

- **Know** the risks of contacting OHPLs and the risk of flashover.
- **Find out** the maximum height and maximum vertical reach of your machine.
- **Find out** the location and route of all Power Lines within the work area.
- **Find out** the operating voltage of all Power Lines within the work area.
- **Contact** the local Distribution Network Operator (DNO) who will be able to advise you on the operating voltage, safe minimum clearance distance for working, and additional precautions required.
- **Never** attempt to operate the machine in exclusion zones.
- **Always** work with extreme caution and plan your work ahead to avoid high risk areas.
- **If doubt exists** do not work in the area – never risk the safety of yourself or others.

Emergency Action for Accidents Involving Electricity

- Never touch an overhead line - even if it has been brought down by machinery, or has fallen. Never assume lines are dead.
- When a machine is in contact with an overhead line, electrocution is possible if anyone touches both the machine and the ground. Stay in the machine and lower any raised parts in contact or drive the machine out of the lines if you can.
- If you need to get out to summon help or because of fire, jump out as far as you can without touching any wires or the machine - keep upright and away.
- Get the electricity company to disconnect the supply. Even if the line appears dead, do not touch it - automatic switching may reconnect the power.

Further information and leaflets on this and other agricultural safety subjects are available on the 'Health & Safety Executive' website at the following address: www.hse.gov.uk/pubns/agindex.htm

MAINTENANCE

⚠ WARNING

Before any work is carried out on the machine the motor must be switched off and the hydraulic unit free of pressure. Remove the ignition key, and secure the carrier vehicle against unintended operation or movement.

⚠ DANGER

Always wear suitable protection such as gloves, safety glasses, safety boots, mask etc. when carrying out maintenance or repair work on this machine.

General Maintenance

- Check nuts, bolts and fixings on a regular basis and retighten if necessary.
- Lubricate grease points at the periods stated below.
- Check condition of the hydraulic hoses on a regularly basis - replace immediately if damaged or excessively worn. Ensure replacement hoses conform to the manufacturer's specifications.
- Check the cutter components on a regular basis and replace any damaged or missing parts immediately; *defective or worn components produce an unclean cut and increase power requirement dramatically – always replace damaged or worn components with genuine parts that are designed specifically for the machine.*
- Check all safety decals are visible and readable, replace unreadable safety decals immediately.
- Clean the machine after each use and prior to storage.

Tools Required

The following tools are required for normal maintenance of the hedge trimmer:



10mm, 17mm & 19mm Spanners and/or Sockets

Torque Wrench

Torque Settings

Pro-drive knife drive bolts M12 x 40	115 Nm
Motor mount and Pro-drive knife drive bolts M12 x 30	115 Nm
Knife protection guard nuts M10	48 Nm
Knife connection bolts M6 x 22, M6 x 18	15 Nm
Knife section nuts M6	15 Nm
Head bearing bolts M10 x 35	81 Nm
Knife head lug bolt M10 x 45	> 72 Nm

Lubrication & Torque Locations

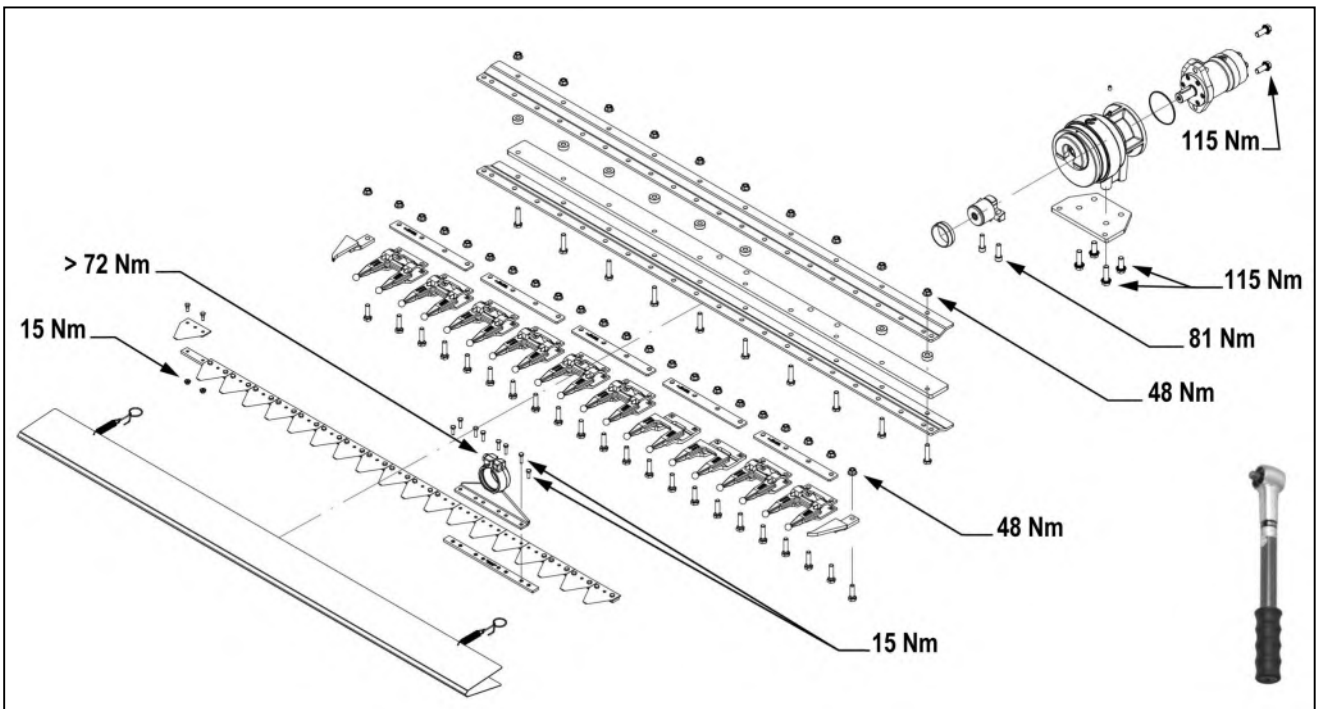
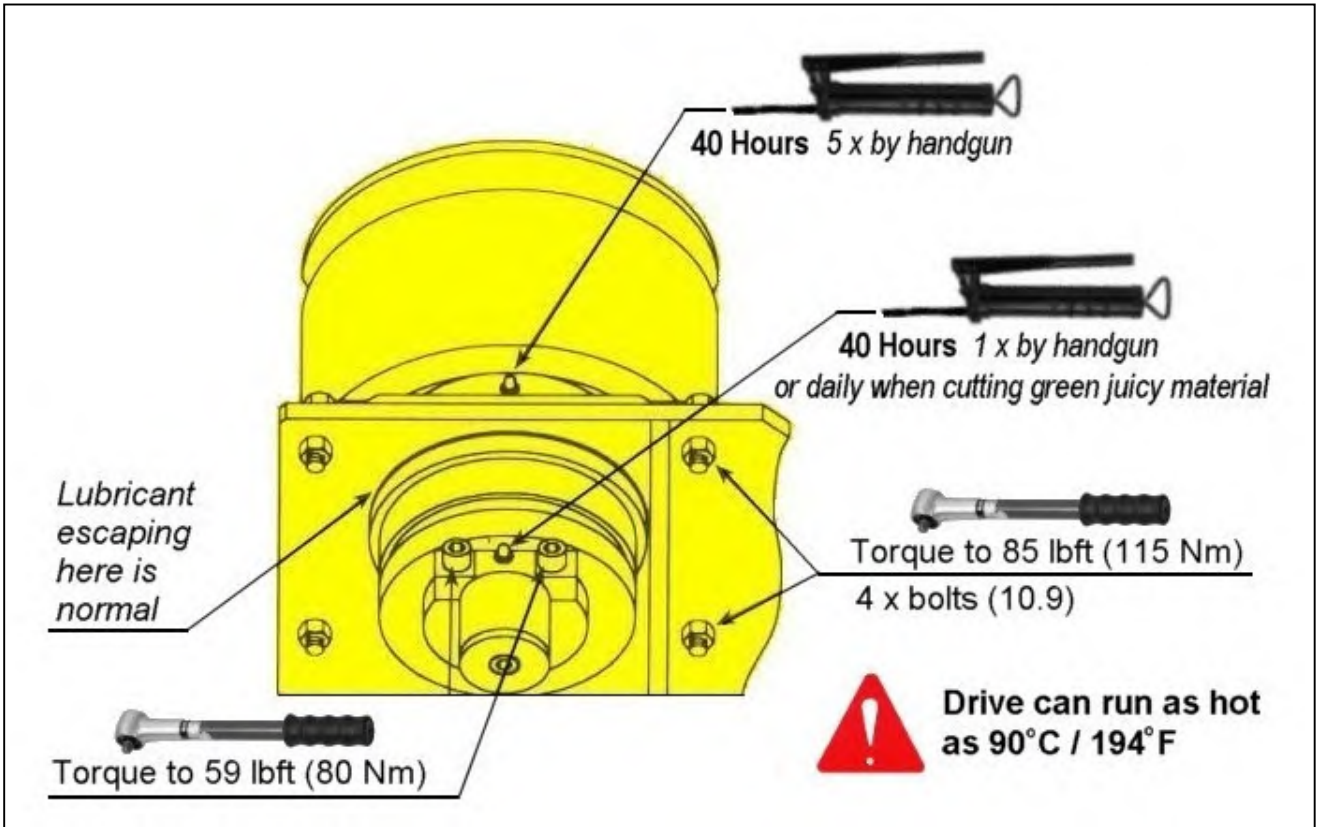

Replacing Sections

In case of breakage, single sections of the installed knives can be replaced.

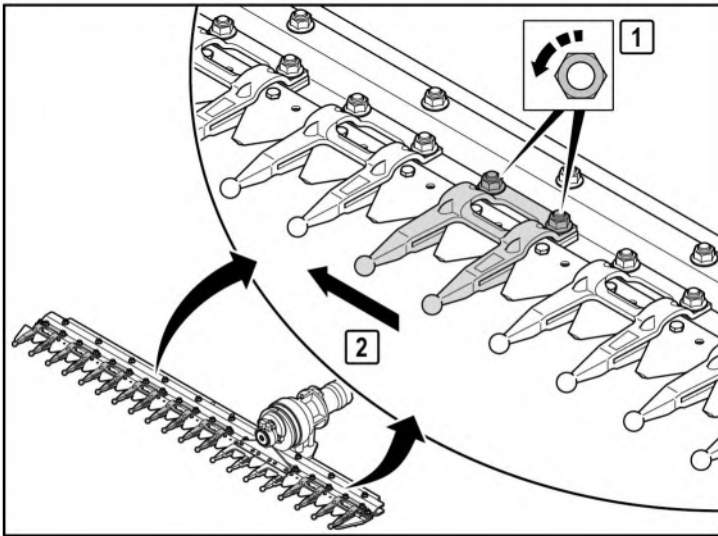

Removing a section

- ▶ Unscrew the nut of the double guard on the damaged section and remove the bolts.
- ▶ Push the double guard to the side in order to access the knife bolts.

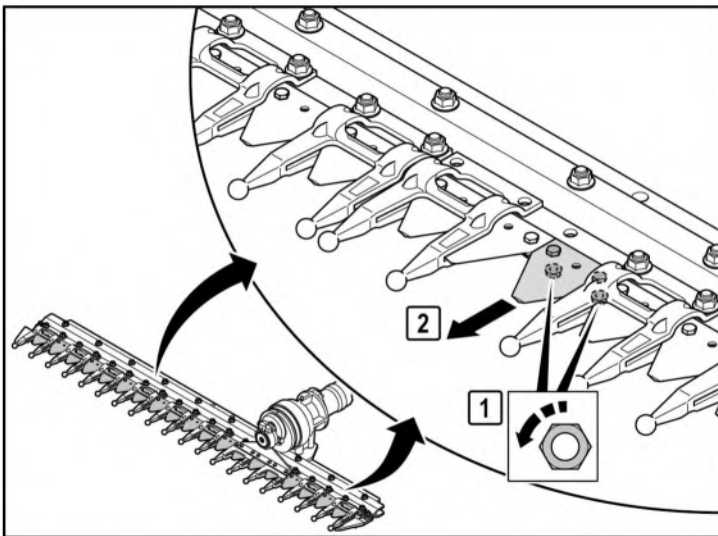

- ▶ Loosen the nuts on the damaged section and tap the serrated stud bolts to remove them.
- ▶ Remove the section from the knife.

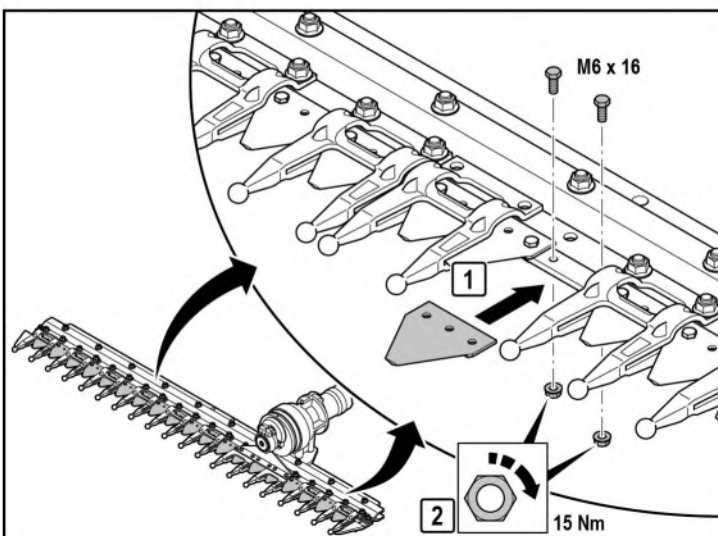

Mounting a section

- ▶ Position the new section on the knife.
- ▶ Insert the serrated stud bolts from above. Always use **new** serrated stud bolts!
- ▶ Tighten the nuts to the specified tightening torque.

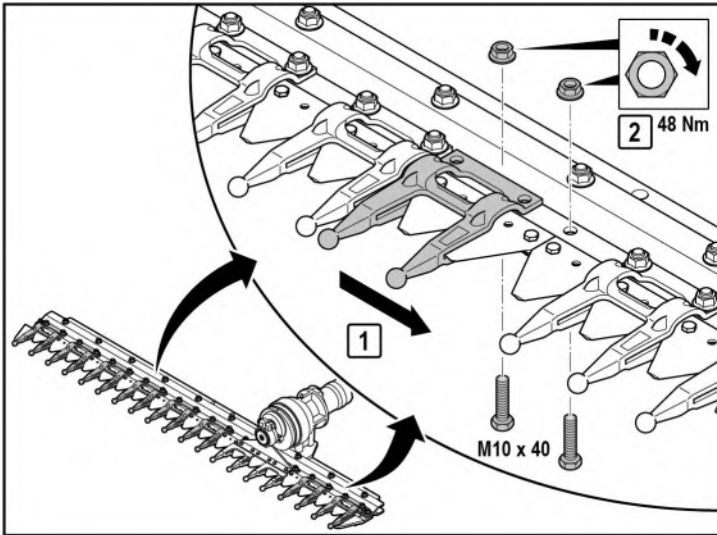

- ▶ Push the double guard back.
- ▶ Insert the bolts.
- ▶ Tighten the nuts to the specified tightening torque.

Changing knives

If the sections are excessively worn, the entire knife must be replaced.

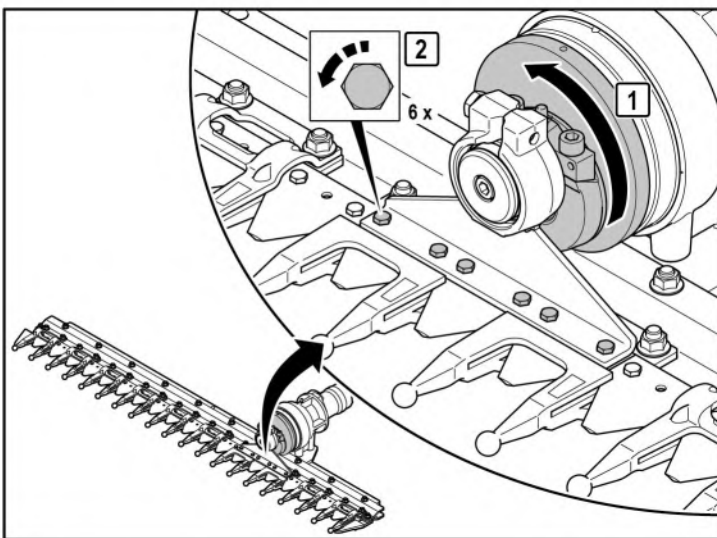

Removing knives

- ▶ Align the knife stroke so that the bolts on the head bearing are on top.
- ▶ Unscrew the bolts on the knife head.

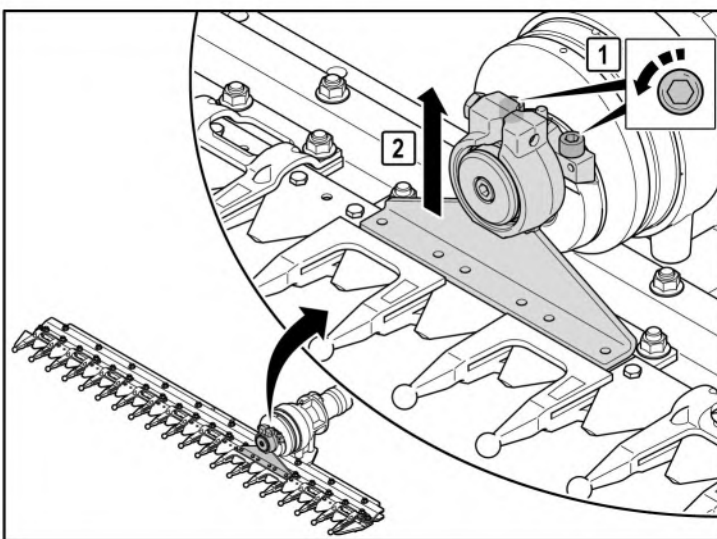

- ▶ Unscrew the bolts on the head bearing.
- ▶ Remove the knife head

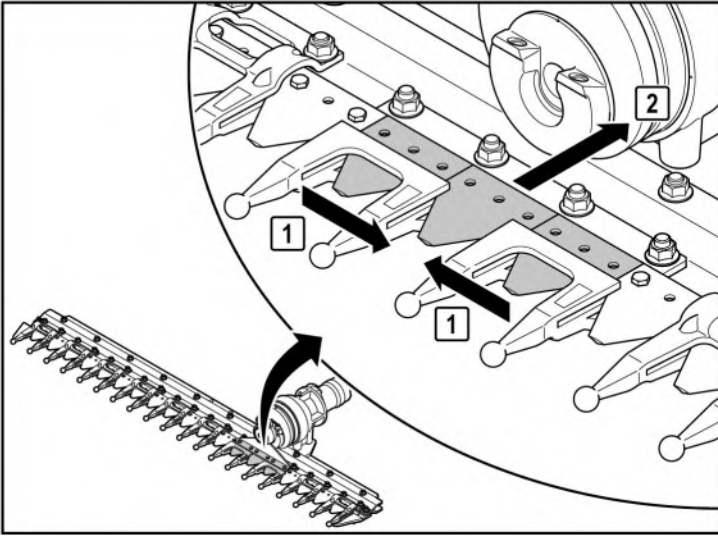

- ▶ Remove the three loose sections toward the rear between the two first guards.

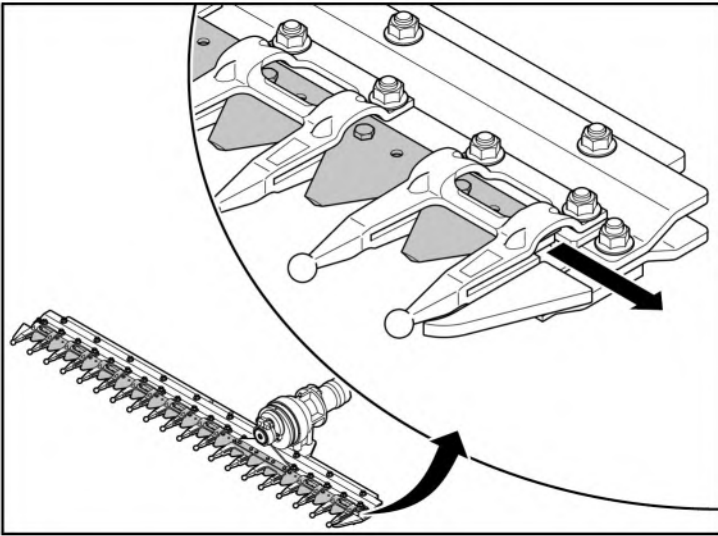

- ▶ Pull the knife carefully to the side to remove it from the finger bar.

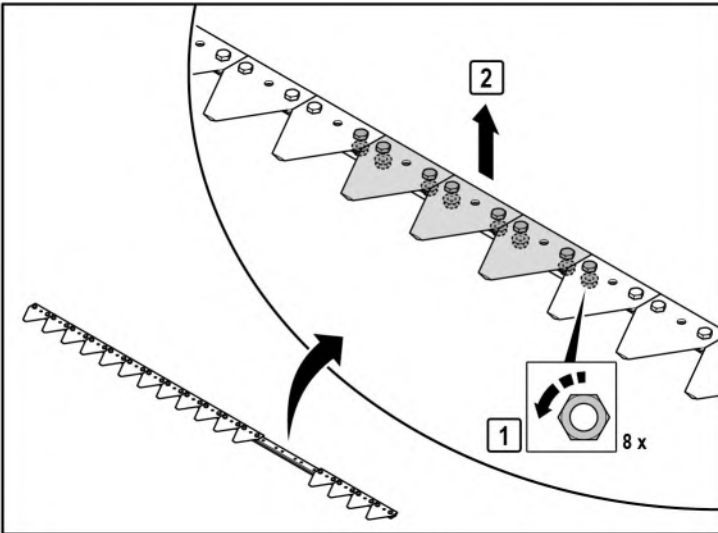

Preparing a new knife for mounting

- ▶ Loosen the nuts on the three sections on which the knife head is to be mounted.
- ▶ Loosen the nuts on both sides of the next section.
- ▶ Tap the serrated stud bolts to remove them.
- ▶ Remove the three sections.

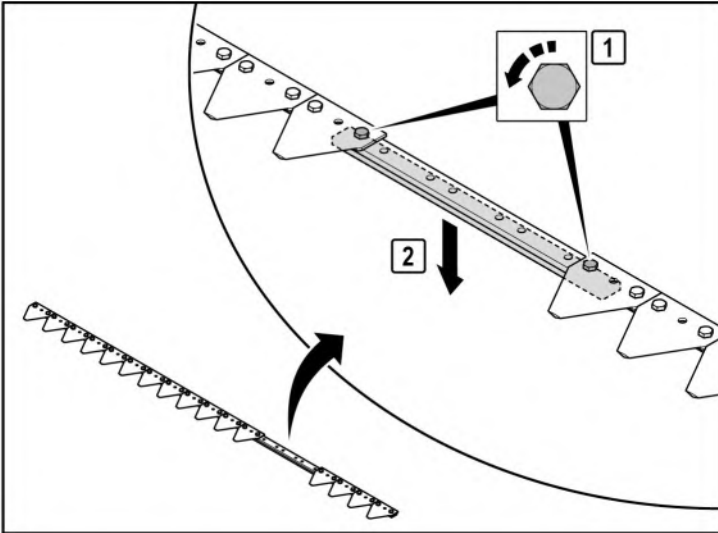

- ▶ Loosen the two outer bolts on the knife connection of the **old** knife.
- ▶ Remove the knife connection.

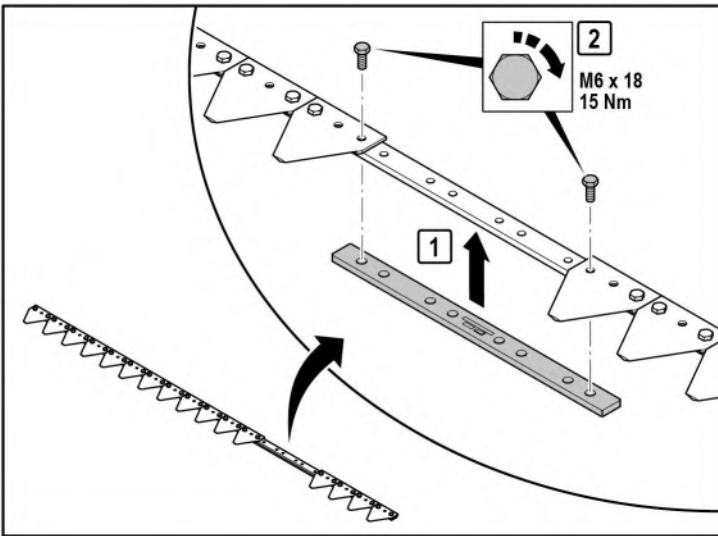

- ▶ Mount the knife connection on the **new** knife.
- ▶ Make sure that the protrusions of the press-in nuts point upward and are seated properly during assembly.
- ▶ Tighten the two bolts to the specified tightening torque.

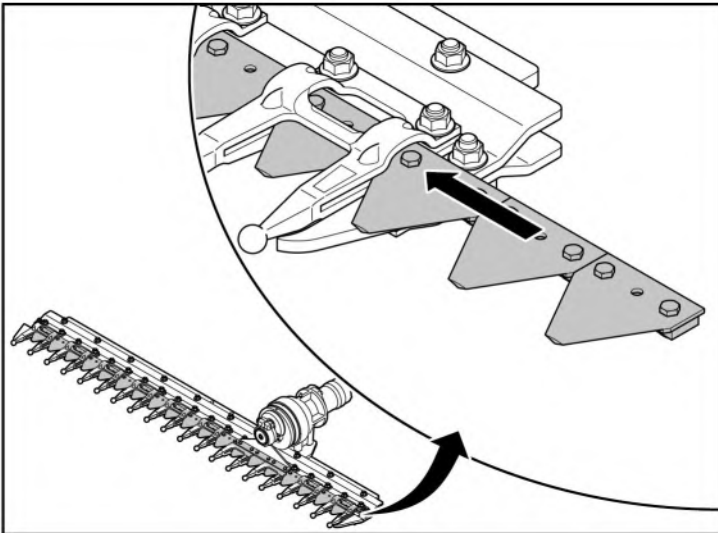

Mount the knife

- ▶ Push the new knife carefully into the guide bar.

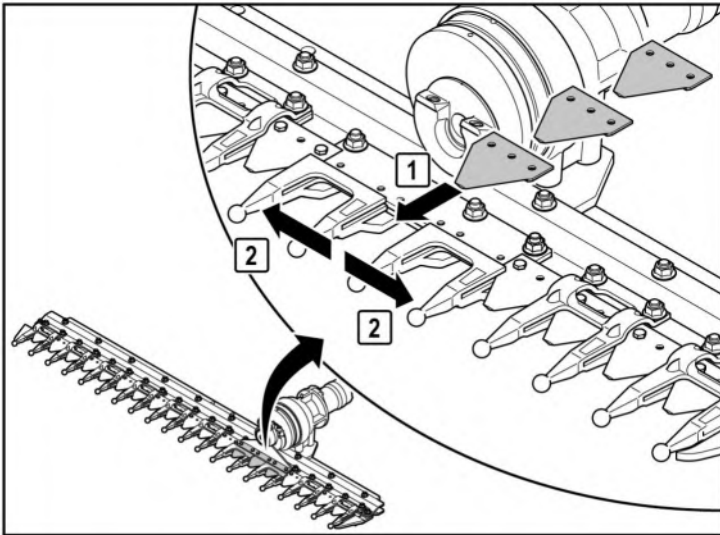

- ▶ Insert the three loose sections from the rear between the two guide fingers and push them into the mounting position.

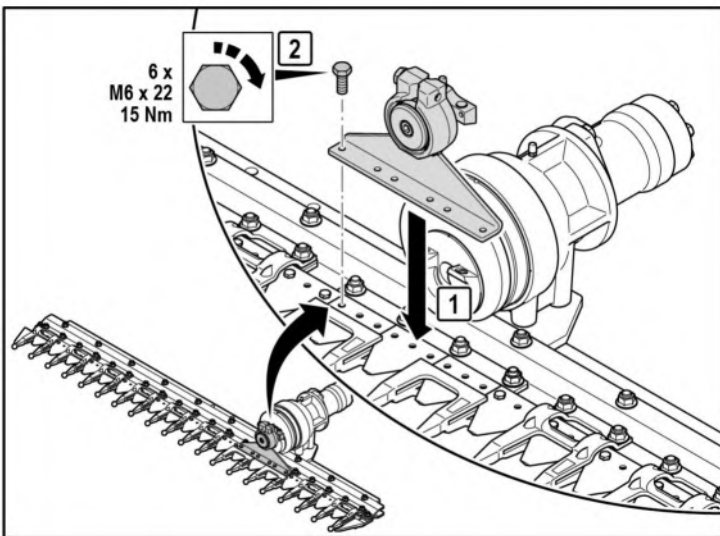

- ▶ Place the knife head on the sections.
- ▶ Tighten the bolts to the specified tightening torque.

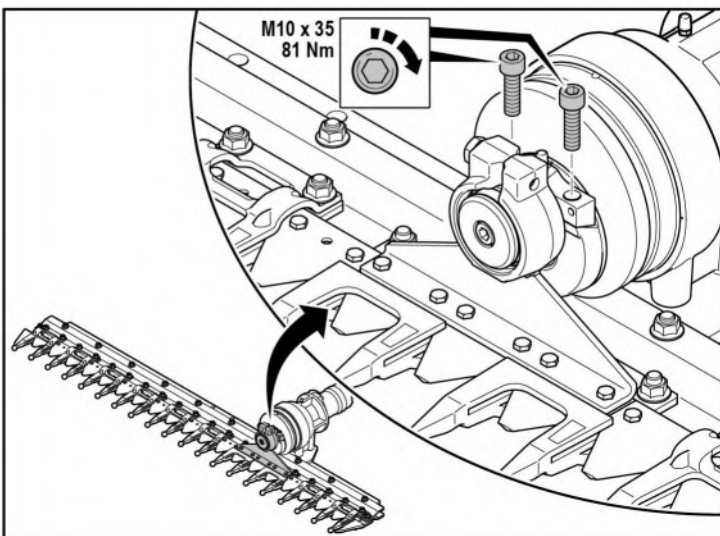

- ▶ Tighten the bolts on the head bearing to the specified tightening torque.

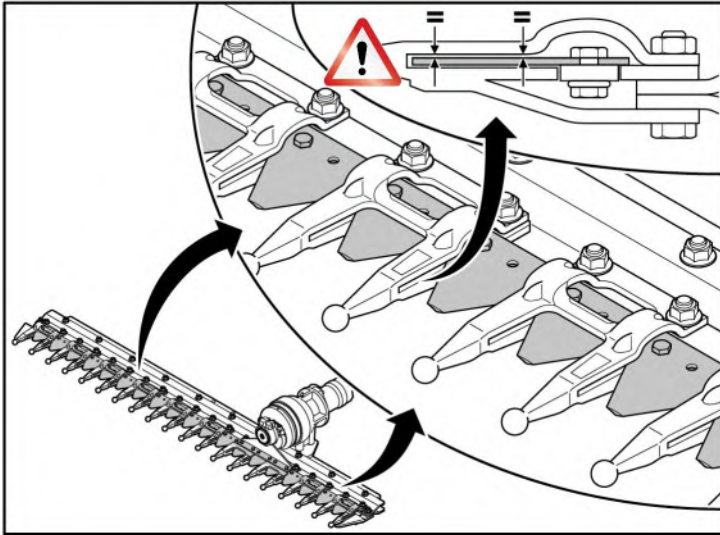

- ▶ Check the cutting gap for parallelism.
- ▶ Observe the section while it runs very slowly; *if the knife scrapes or does not run straight in the cutting gap, the cause must be determined and eliminated.*

Replace the Guard

A guard must be replaced if it is bent or damaged, or if the cutting gap has reached the wear mark of **5.4mm**.

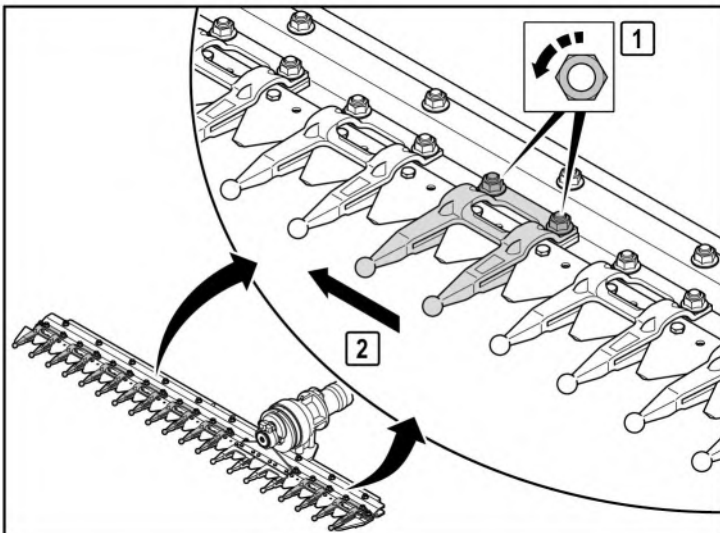

Remove the double guard

- ▶ Unscrew the nuts on the damaged double guard and remove the bolts.
- ▶ Push the double guard to the side in order to access the knife bolts.

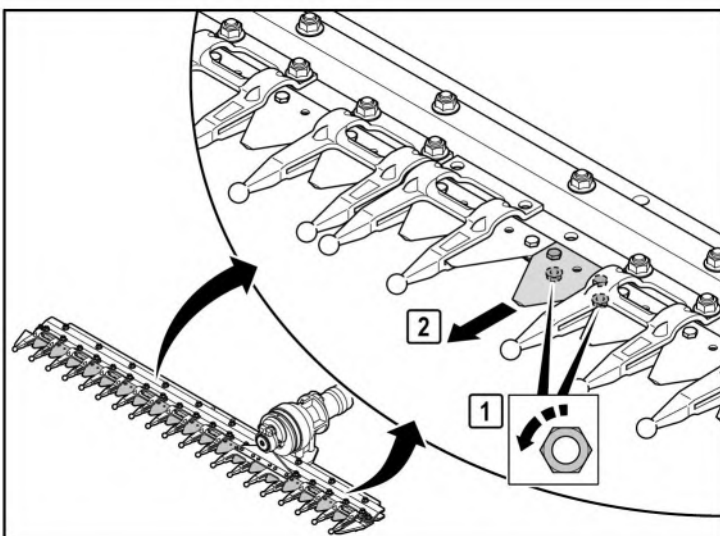

- ▶ Loosen the nuts on the corresponding section and tap the serrated stud bolts to remove them.
- ▶ Remove the section from the knife.

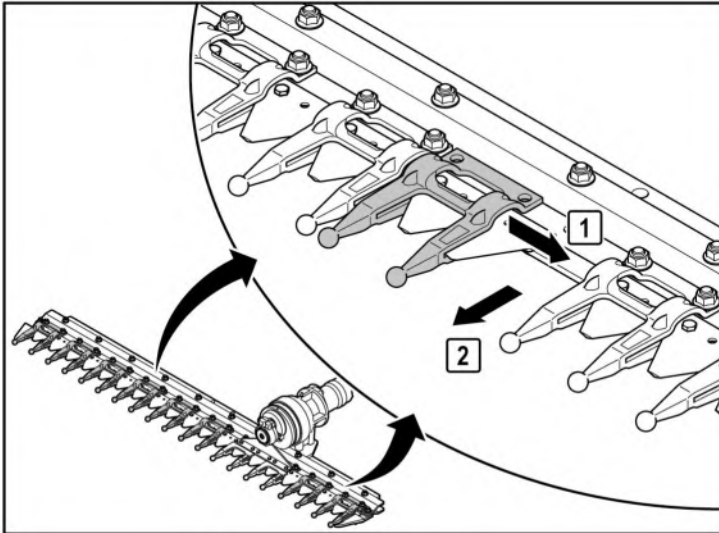

- ▶ Push the double guard through the resulting gap in the knife.

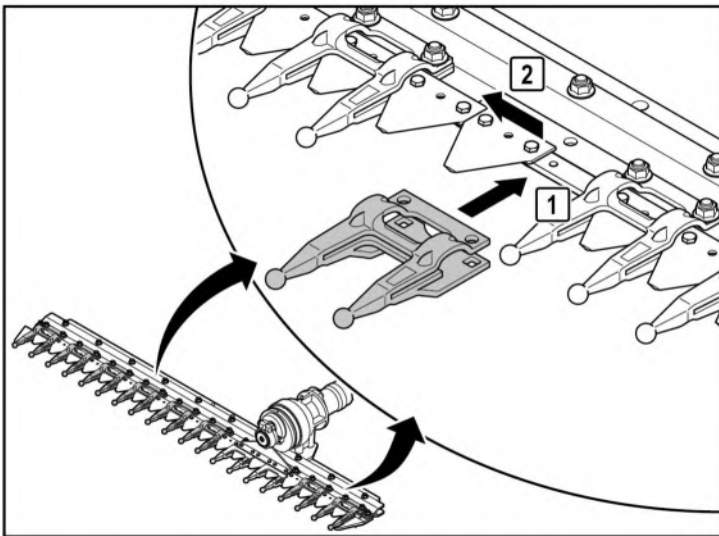

Mount the double guard

- ▶ Push the new double guard through the gap in the knife.
- ▶ Push the double guard aside.

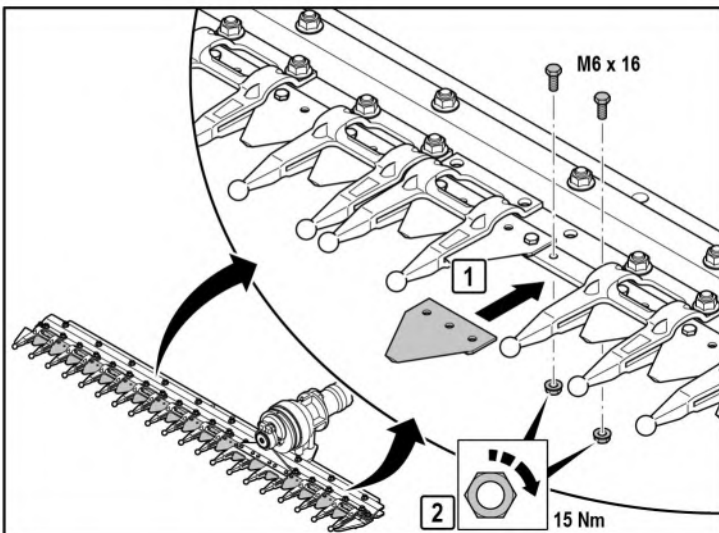

- ▶ Position the section on the knife.
- ▶ Insert the serrated stud bolts from above.
Always use **new** serrated stud bolts!
- ▶ Tighten the nuts to the specified tightening torque.

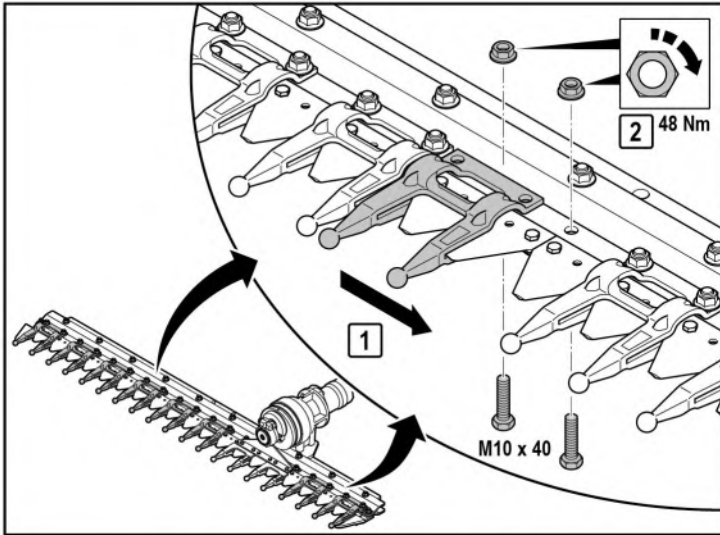

- ▶ Push the double guard back.
- ▶ Insert the bolts.
- ▶ Tighten the nuts to the specified tightening torque.

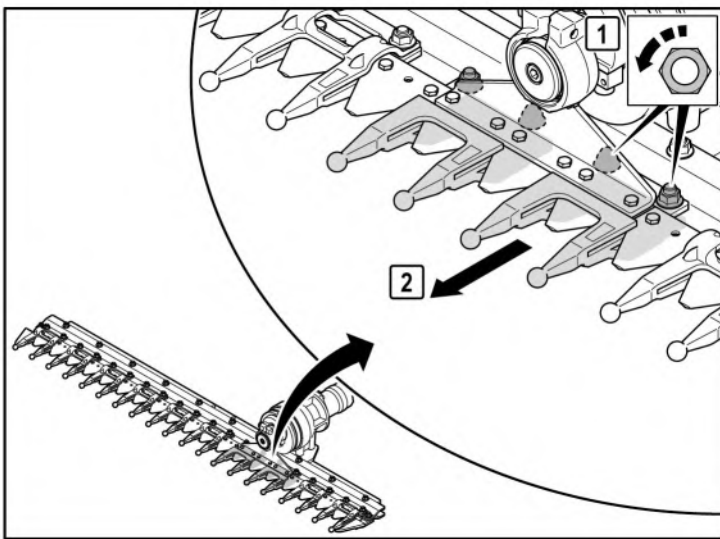

Remove the first guard V/O

- ▶ Unscrew the nuts on the first guard V/O and remove the bolts.
- ▶ Remove the first guard V/O from the profile bar.

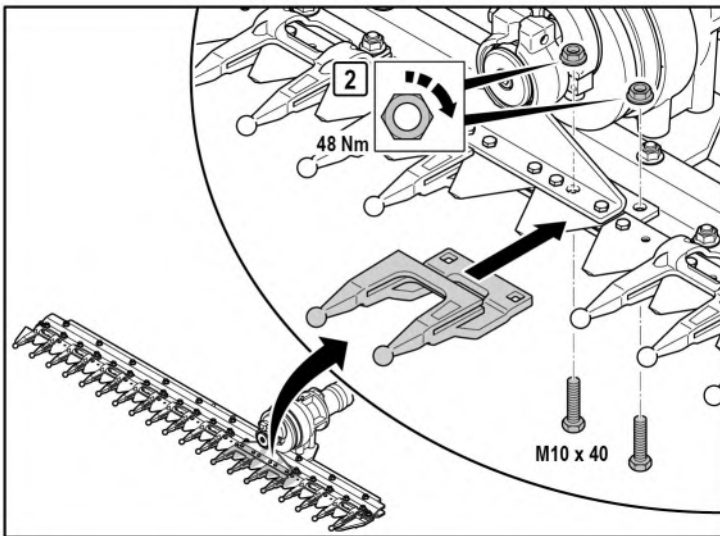

Attach first guard V/O

- ▶ Position the first guard V/O below the profile bar.
- ▶ Insert the bolts.
- ▶ Tighten the nuts to the specified tightening torque.

Replace the Safety Finger

If the position of the safety finger on the guard is not correct, it can be aligned to correct this. Damaged safety fingers must be replaced immediately.

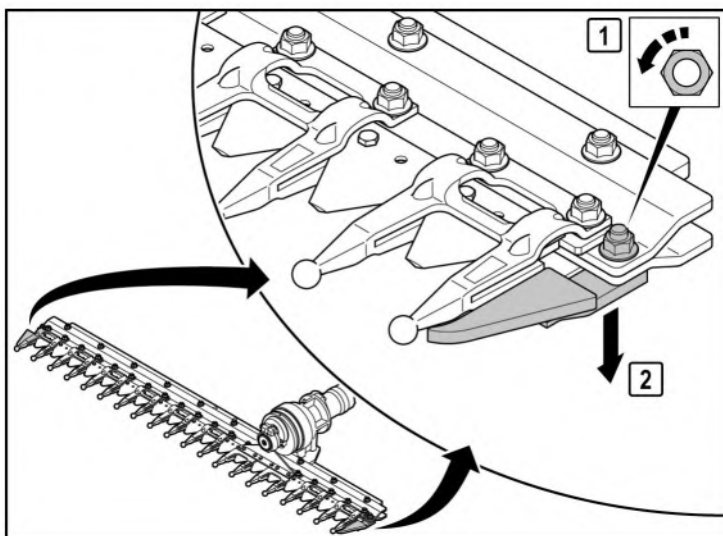

Remove the safety finger

- ▶ Unscrew the nut on the safety finger and remove the bolt.
- ▶ Remove the safety finger from the profile bar.

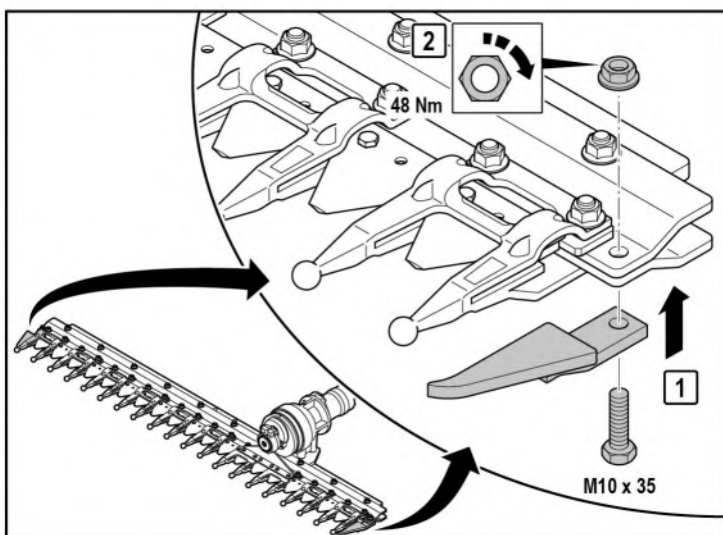

Mount the safety finger

- ▶ Position the safety finger beneath the profile bar.
- ▶ Insert the bolt and tighten the nut to the specified tightening torque.

Replace the Wear Plate

If the wear plates are worn, they must be replaced.

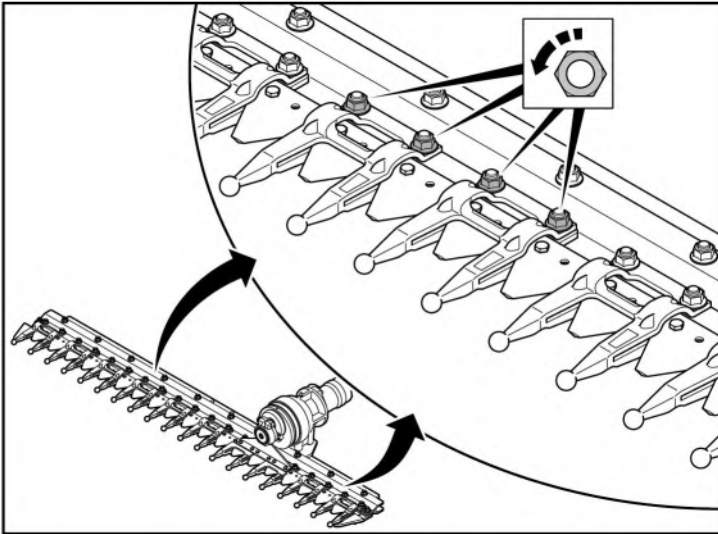

Remove the wear plate

- ▶ Unscrew the nuts of the two double guards on the worn wear plate and remove the bolts.

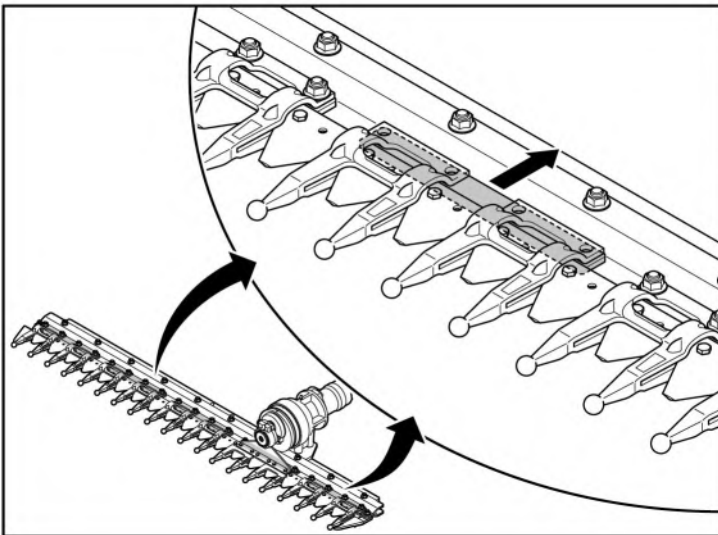

- ▶ Push the worn wear plate out to the rear over the profile bar.

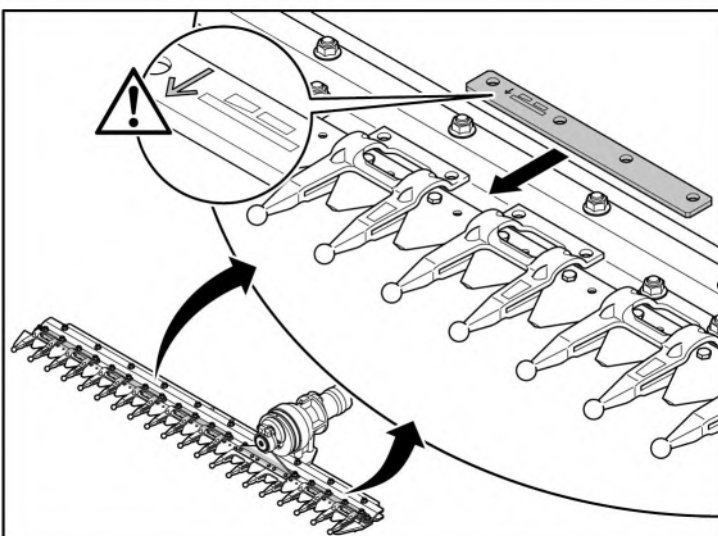

Mount the wear plate

- ▶ Push the new wear plate from the rear between the profile bar and guard. The arrow on the wear plate must point in the direction of travel.

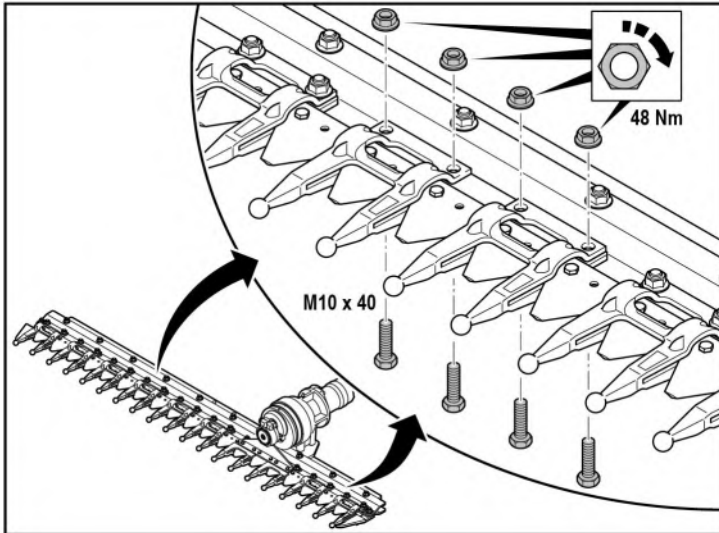

- ▶ Position the two guards correctly on the wear plate.
- ▶ Insert the bolts.
- ▶ Tighten the nuts to the specified tightening torque.

Replacing the Knife Head

If the knife head is bent, damaged or deformed, it must be replaced immediately.

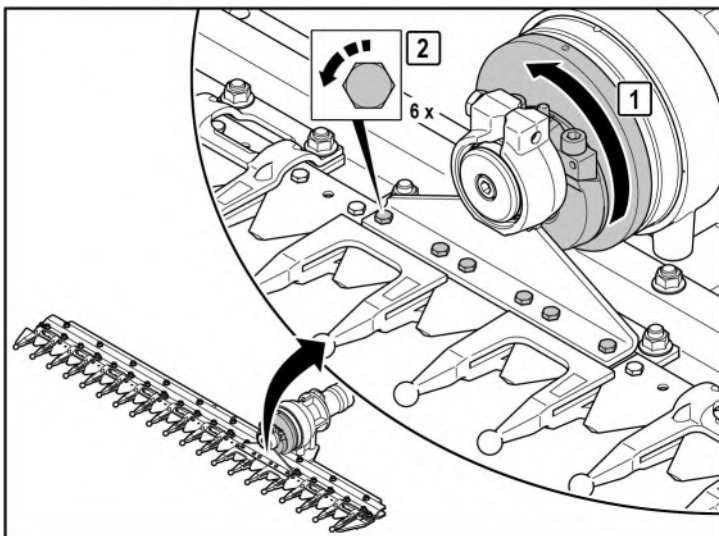

Removing the knife head

- ▶ Align the knife stroke so that the bolts on the head bearing are on top.
- ▶ Unscrew the bolts on the knife head.

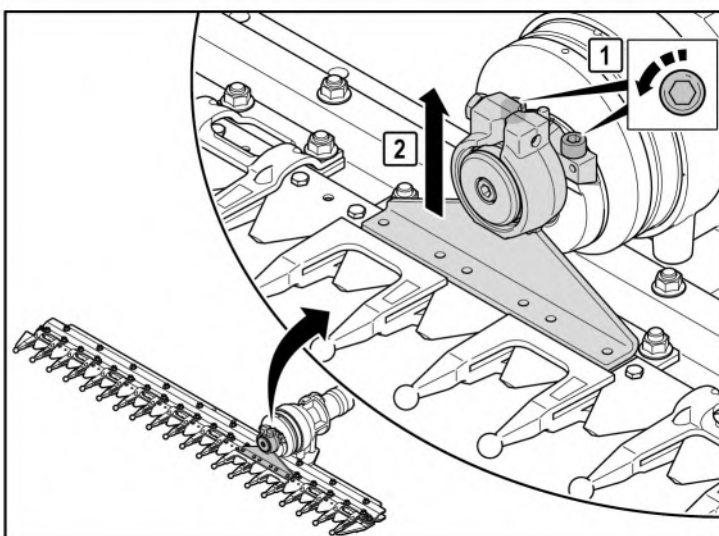

- ▶ Unscrew the bolts on the head bearing.
- ▶ Remove the knife head from the Sections; *watch out for loose sections.*

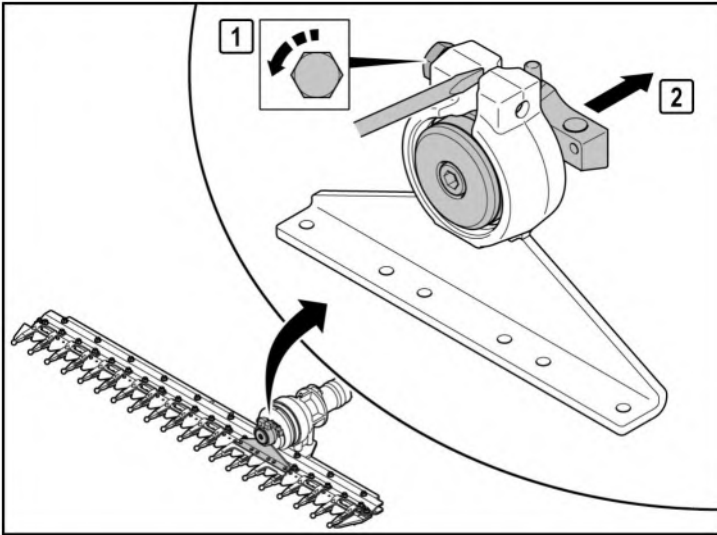

Dismantling the head bearing

- ▶ Loosen the bolt on the knife head.
- ▶ Remove the head bearing from the knife head. You can spread the knife head somewhat by inserting a small screwdriver into the slot of the knife head.

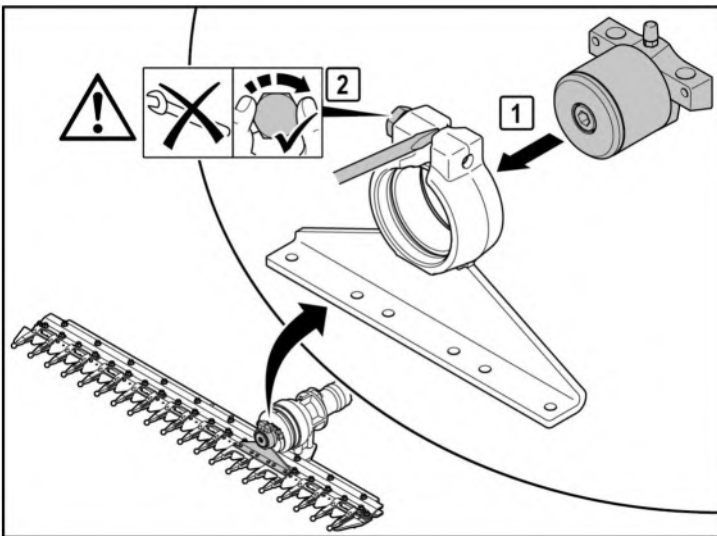

Installing the head bearing

- ▶ Insert the head bearing in the new knife head and align it roughly. You can spread the knife head somewhat by inserting a small screwdriver into the slot of the knife head.
- ▶ Tighten the bolt hand-tight.

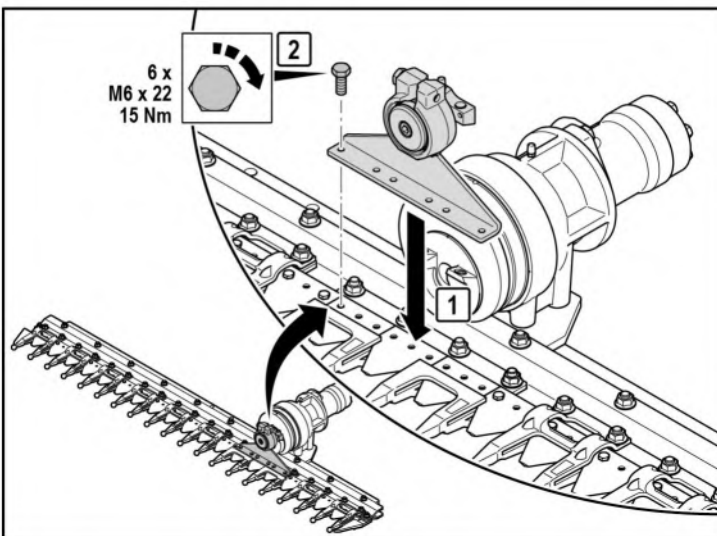

Mounting the knife head

- ▶ Place the knife head on the sections.
- ▶ Tighten the bolts to the specified tightening torque.

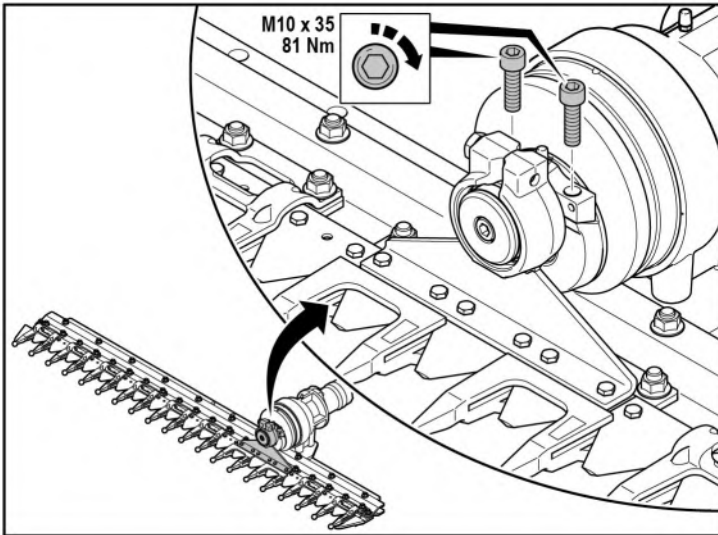

- ▶ Tighten the bolts on the head bearing to the specified tightening torque.

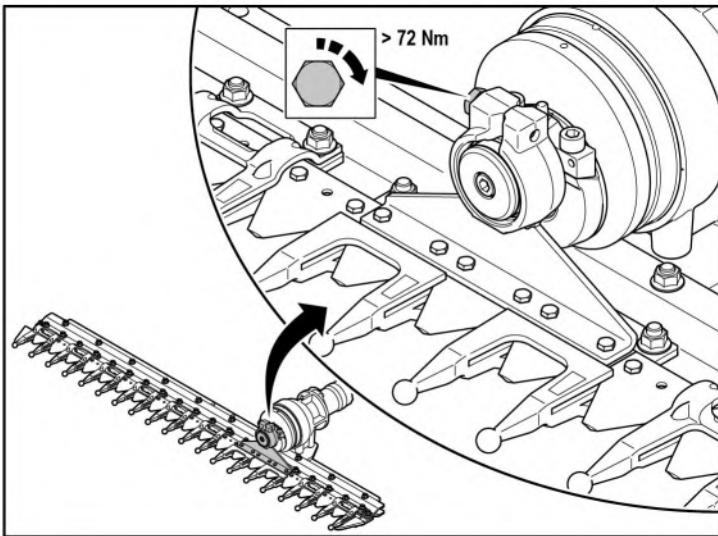

- ▶ Tighten the bolt on the head bearing to the specified tightening torque.

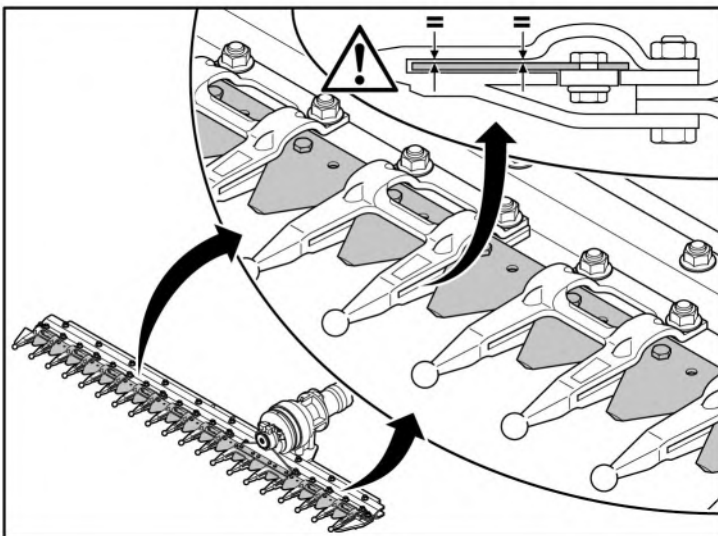

- ▶ Check the cutting gap for parallelism.
- ▶ Observe the section while it runs very slowly; *if the knife scrapes or does not run straight in the cutting gap, the cause must be determined and eliminated.*

TROUBLESHOOTING

Problem	Possible Cause	Remedy
Cutting blade does not move	<ul style="list-style-type: none"> - Incorrect connection - Pump not started - Foreign object in cutter mechanism - Defective motor - Defective cutting blade gear 	<ul style="list-style-type: none"> - Check connections - Retighten screw connections - Switch on pump (<i>If necessary check circuit breaker on vehicle</i>) - Remove foreign object - Replace defective components
Not cutting cleanly	<ul style="list-style-type: none"> - Cutters, blades / cutting blade and guide plates worn - Speed of cutting blade drive incorrect 	<ul style="list-style-type: none"> - Replace defective components - Contact specialist workshop
Cutting blade drive does not pull through	<ul style="list-style-type: none"> - Oil quantity/pressure incorrect 	<ul style="list-style-type: none"> - Consult specialist workshop
Extreme oscillation and / or vibration	<ul style="list-style-type: none"> - Coupling star defective - Motor/blade speed too high 	<ul style="list-style-type: none"> - Replace defective part - Consult specialist workshop



McConnel Limited, Temeside Works, Ludlow, Shropshire SY8 1JL. England.
Telephone: 01584 873131. Facsimile: 01584 876463. www.mcconnel.com