

Publication 173
July 1992
Part No. 71 93 859



PA93 & PA9058

Classic

OPERATOR'S MANUAL



McCONEl

IMPORTANT

VERIFICATION OF WARRANTY REGISTRATION

(Applies to UK Machines only)



UK DEALER WARRANTY INFORMATION & REGISTRATION VERIFICATION

It is imperative that the selling dealer registers this machine with McConnel Limited within 7 days of delivery to the end user – failure to do so may affect the validity of the machine warranty.

To register a machine go to the McConnel Limited web site at www.mcconnel.com, log on to '**DEALER INSIDE**' and select the '**Machine Registration button**' which can be found in the Service Section of the site. Confirm to the customer that the machine has been registered in the section below.

Should you experience any problems registering a machine in this manner please contact the McConnel Service Department on 01584 875848.

Registration Verification (UK Machines)

| |
|--|
| Dealer Name: |
| Dealer Address: |
| Customer Name: |
| Date of Warranty Registration:/...../..... Dealer Signature: |

NOTE TO CUSTOMER / OWNER

Please ensure that the above section above has been completed and signed by the selling dealer to verify that your machine has been registered with McConnel Limited.

EC DECLARATION OF CONFORMITY

Conforming to EEC Directive 89/392/EEC

We,

McCONNEL LIMITED,

Temeside Works, Ludlow, Shropshire SY8 1JL.

Declare under our sole responsibility that:

The product (*type*) *Tractor Mounted Hedgecutter/Trimmer*.....

.....

Product Code *PA91, PA92, PA93, MA48, PA58, MA39, MA45*.....

Serial No. & Date Type

Manufactured by the above company/*

.....

(insert business name and full address if not stated above)*

Complies with the required provisions of the Directive 89/392/CEE, and AMD 91/368/CEE, AMD 93/44/CEE, AMD 93/63/CEE and conforms with European Norm. BS EN 292.

Part 1: 1991 – Safety of Machinery – Terminology, methodology.

Part 2: 1991 – Safety of Machinery – Technical Specifications.

and other national standards associated with its design and construction as listed in the Technical File.

Signed *John Frank*.....
on behalf of McCONNEL LIMITED *Responsible Person*

Chief Design Engineer *May 2004*.....
Status *Date*

EC DECLARATION OF CONFORMITY

Conforming to EEC Directive 89/392/EEC

We,

McCONNEL LIMITED,

Temeside Works, Ludlow, Shropshire SY8 1JL.

Declare under our sole responsibility that:

The product (type) *Flail Head*

.....

Product Code *BD12, BD16, F110, F112, F115, F012, F016*

Serial No. & Date Type

Manufactured by the above company/*

.....

(insert business name and full address if not stated above)*

Complies with the required provisions of the Directive 89/392/CEE, and AMD 91/368/CEE, AMD 93/44/CEE, AMD 93/63/CEE and conforms with European Norm. BS EN 292.

Part 1: 1991 – Safety of Machinery – Terminology, methodology.

Part 2: 1991 – Safety of Machinery – Technical Specifications.

and other national standards associated with its design and construction as listed in the Technical File.

Signed *John Fawk*

on behalf of McCONNEL LIMITED

Responsible Person

Chief Design Engineer

Status

May 2004

Date



READ THE BOOK FIRST

It might save hours and pounds later !

When ordering spare parts always quote

- ***The Machine Type***
- ***The Machine Serial Number***
- ***The Part Number***

Factory re-built service exchange units of the major hydraulic components are available from your Dealer

NOISE

The equivalent daily personal noise exposure from this machine, measured at the operators' ear, is within the range 78 – 85 DB.

These figures apply to a normal distribution of use where the noise fluctuates between zero and maximum. The figures assume that the machine is fitted to a tractor with a quiet cab with the windows closed in a generally open environment. We recommend that the windows are kept closed.

With the cab rear window open the equivalent daily personal noise exposure will increase to a figure within the range 82 – 88 DB.

At equivalent daily noise exposure levels of between 85 and 90 DB, ear protection is recommended, it should be used if any window is left open.

LIST OF CONTENTS

Page No.

| | |
|--|----|
| GENERAL INFORMATION | 1 |
| INTRODUCTION | 2 |
| SAFETY INFORMATION | 4 |
| FITTING | 9 |
| Tractor Selection | 9 |
| Linkage Requirements | 9 |
| Linkage Isolation | 9 |
| Check Chains/Stabilisers | 9 |
| Tractor Relief Valve | 9 |
| Tractor Hydraulic Flow Rates | 9 |
| PTO Shaft | 9 |
| Tractor Preparation | 10 |
| Operator Guard Fitting | 10 |
| Wheel Width | 10 |
| Ballast Weight | 10 |
| Lift Links | 10 |
| Closed Centre Conversion Kit – <i>Si Models only</i> | 11 |
| Oil Requirements | 12 |
| Delivery | 13 |
| Attachment to Tractor | 13 |
| Fitting Control Unit in Cab | 16 |
| Running Up Procedure | 18 |
| Removal from Tractor | 19 |
| Storage | 19 |
| OPERATION | 20 |
| Limitation | 20 |
| Operator Guard | 20 |
| Preparation | 20 |
| Machine Controls | 21 |
| Main Control Valve – <i>Cable Models</i> | 21 |
| Main Control Valve – <i>Electric Models</i> | 21 |
| Head Angle Float – <i>PA9058 Models only</i> | 22 |
| Rotor Valves | 23 |
| Moving into the Transport Position | 24 |
| Moving from Transport to Work Position | 24 |
| Engaging Drive | 24 |
| Rotor Operating Speed | 25 |
| Forward Speed | 25 |
| Highway Working | 25 |
| Working Practices | 26 |
| Breakaway | 26 |
| Auto Head Control – <i>PA93E-AHC only</i> | 26 |
| Wire Trap | 27 |
| Removing Wire from Rotor | 27 |
| Overhead Obstructions | 27 |
| High Voltage Cables | 27 |

LIST OF CONTENTS (Continued)

Page No.

| | |
|---|----|
| Hedge Cutting Procedure | 28 |
| Preliminary Precautions | 28 |
| Upward Cutting | 28 |
| Downward Cutting | 28 |
| Reversing Rotation – <i>Ti Models only</i> | 28 |
| Reversing Rotation – <i>Si Models only</i> | 29 |
| Grass Cutting | 29 |
| Roller Positions | 30 |
| Cutting sequence | 32 |
| Lift Float Kit – <i>Optional Extra</i> | 33 |
| Angle Float – <i>Optional Extra on Electric Models only</i> | 34 |
| MAINTENANCE | 35 |
| Lubrication | 35 |
| General | 35 |
| PTO Shaft | 35 |
| Hydraulic System | 36 |
| Flail Head | 37 |
| Cables | 37 |
| Hydraulic Hoses | 38 |
| PTO Gearbox | 38 |
| Hose Connections | 39 |
| Main Control Valve – <i>PA93 Cable Models</i> | 39 |
| Main Control Valve – <i>PA9058 Cable Models</i> | 40 |
| Main Control Valve – <i>PA93 Electric & Electric AHC Models</i> | 41 |
| Main Control Valve – <i>PA9058 Electric Models</i> | 42 |
| Rotor Valves | 43 |

GENERAL INFORMATION

Read this manual before fitting or operating the machine. Whenever any doubt exists contact your dealer or the McConnell Service Department for assistance.

Use only McConnell Genuine spare parts on McConnell equipment and machines.

DEFINITIONS - *The following definitions apply throughout this manual:*

WARNING

An operating procedure, technique etc., which can result in personal injury or loss of life if not observed carefully.

CAUTION

An operating procedure, technique etc., which can result in the damage of either machine or equipment if not observed carefully.

NOTE

An operating procedure, technique etc., which is considered essential to emphasise.

LEFT AND RIGHT HAND

This term is applicable to the machine when fitted to the tractor and viewed from the rear. This also applies to tractor references.

| | |
|--|---------------------------|
| Record the Serial Number of your machine on this page and always quote this number when ordering parts. Whenever information concerning the machine is requested remember to also state the type and model of tractor on which the machine is fitted. | |
| Machine Serial No. | Installation Date: |
| Machine Model Details: | |
| Dealer Name: | |
| Dealer Address: | |
| Dealer Telephone No: | |

INTRODUCTION – PA93 Models

PA 93 SERIES – All Models

*Linkage mounted.
Right or left hand cutting.
1.2 metre Hedge or grass heavy duty flail head.
Spring assisted gravity breakaway.
Operator guard.
44 gallon (200 litre) hydraulic reservoir.*

PA93 Si

*Semi independent hydraulics – tractor power for arm movement. PTO pump for rotor.
Cable controls.
Rotor engagement by tractor's PTO lever.
Choice of 45h.p. or 54 h.p, hydraulic systems.*

PA93 Ti

*Totally independent hydraulics powered by tandem PTO pump.
Cable controls.
Independent reversible Rotor on/off valve.
Choice of 45 h.p. or 54 h.p. hydraulic systems.*

PA93 E

*Totally independent hydraulics powered by tandem PTO pump.
Electric controls solenoid operated.
Independent reversible Rotor on/off valve.
Choice of 45 h.p. or 54 h.p. hydraulic systems.*

PA93 E - AHC

*Totally independent hydraulics powered by tandem pump.
Electric controls solenoid operated.
Independent reversible Rotor on/off valve.
54 h.p. hydraulic system.
Auto head control.*

INTRODUCTION – PA9058 Models

PA 9058 SERIES – All Models

*Linkage mounted.
Right or left hand cutting.
1.2 metre Hedge or grass light duty flail head.
Hydraulic assisted gravity breakaway.
Operator guard.
44 gallon (200 litre) hydraulic reservoir.
Head angle float.
45 hp hydraulicsystem.*

PA 9058 Si

*Semi independent hydraulics - tractor power for arm movement. PTO pump for rotor.
Cable controls.
Rotor engagement by tractor's PTO lever.*

PA9058 Ti

*Totally independent hydraulics powered by tandem PTO pump.
Cable controls.
Independent reversible Rotor on/off valve.*

PA9058 E

*Totally independent hydraulics powered by tandem PTO pump.
Electric controls solenoid operated.
Independent reversible Rotor on/off valve.*



SAFETY INFORMATION

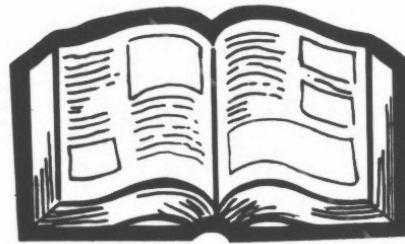

This machine has the potential to be extremely dangerous, in the wrong hands it can kill or maim. It is therefore imperative that both owner, and operator of this machine, read and understand the following section to ensure that they are fully aware of the dangers that do, or may exist, and their responsibilities surrounding the use and operation of the machine.

The operator of this machine is responsible not only for their own safety but equally for the safety of others who may come into the close proximity of the machine, as the owner you are responsible for both.

When the machine is not in use the cutting head should be lowered to rest on the ground. In the event of a fault being detected with the machine's operation it should be stopped immediately and not used again until the fault has been corrected by a qualified technician.

POTENTIAL SIGNIFICANT DANGERS ASSOCIATED WITH THE USE OF THIS MACHINE:

- *Being hit by debris thrown by rotating components.*
- *Being hit by machine parts ejected through damage during use.*
- *Being caught on a rotating power take-off (PTO) shaft.*
- *Being caught in other moving parts i.e.: belts, pulleys and cutting heads.*
- *Electrocution from Overhead Power Lines (by contact with or 'flashover' from).*
- *Being hit by cutting heads or machine arms as they move.*
- *Becoming trapped between tractor and machine when hitching or unhitching.*
- *Tractor overbalancing when machine arm is extended.*
- *Injection of high-pressure oil from hydraulic hoses or couplings.*
- *Machine overbalancing when freestanding (out of use).*
- *Road traffic accidents due to collision or debris on the road.*

BEFORE USING THIS MACHINE YOU MUST:

- *Ensure you read all sections of the operator handbook.*
- *Ensure the operator is, or has been, properly trained to use the machine.*
- *Ensure the operator has been issued with and reads the operator handbook.*
- *Ensure the operator understands and follows the instructions in operator handbook.*
- *Ensure the tractor front, rear and side(s) are fitted with metal mesh or polycarbonate guards of suitable size and strength to protect the operator against thrown debris or parts.*
- *Ensure tractor guards are fitted correctly, are undamaged and kept properly maintained.*
- *Ensure that all machine guards are in position, are undamaged, and are kept maintained in accordance with the manufacturer's recommendations.*
- *Ensure flails and their fixings are of a type recommended by the manufacturer, are securely attached and that none are missing or damaged.*
- *Ensure hydraulic pipes are carefully and correctly routed to avoid damage by chaffing, stretching or pinching and that they are held in place with the correct fittings.*
- *Always follow the manufacturer's instructions for attachment and removal of the machine from the tractor.*
- *Check that the machine fittings and couplings are in good condition.*
- *Ensure the tractor meets the minimum weight recommendations of the machine manufacturer and that ballast is used as necessary.*
- *Always inspect the work area thoroughly before starting to note obstacles and remove wire, bottles, cans and other debris.*
- *Use clear suitably sized warning signs to alert others to the nature of the machine working within that area. Signs should be placed at both ends of the work site. (It is recommended that signs used are of a size and type specified by the Department of Transport and positioned in accordance with their and the Local Highways Authority guidelines).*
- *Ensure the operator is protected from noise. Ear defenders should be worn and tractor cab doors and windows must be kept closed. Machine controls should be routed through proprietary openings in the cab to enable all windows to be shut fully.*
- *Always work at a safe speed taking account of the conditions i.e.: terrain, highway proximity and obstacles around and above the machine.*
- *Extra special attention should be applied to Overhead Power Lines. Some of our machines are capable of reach in excess of 8 metres (26 feet) this means they have the potential to well exceed, by possibly 3 metres (9' 9"), the lowest legal minimum height of 5.2 metres from the ground for 11,000 and 33,000 volt power lines. It cannot be stressed enough the dangers that surround this capability, it is therefore vital that the operator is fully aware of the maximum height and reach of the machine, and that they are fully conversant with all aspects regarding the safe minimum distances that apply when working with machines in close proximity to Power Lines. (Further information on this subject can be obtained from the Health & Safety Executive or your Local Power Company).*
- *Always disengage the machine, kill the tractor engine, remove and pocket the key before dismounting for any reason.*

- *Always clear up all debris left at the work area, it may cause hazard to others.*
- *Always ensure when you remove your machine from the tractor that it is left in a safe and stable position using the stands and props provided and secured if necessary.*

WHEN NOT TO USE THIS MACHINE:

- *Never attempt to use this machine if you have not been trained to do so.*
- *Never uses a machine until you have read and understood the operator handbook, are familiar with, and practiced the controls.*
- *Never use a machine that is poorly maintained.*
- *Never use a machine if guards are missing or damaged.*
- *Never use a machine on which the hydraulic system shows signs of wear or damage.*
- *Never fit, or use, a machine on a tractor that does not meet the manufacturer's minimum specification level.*
- *Never use a machine fitted to a tractor that does not have suitable front, rear and side(s) cab guarding made of metal mesh or polycarbonate.*
- *Never use the machine if the tractor cab guarding is damaged, deteriorating or badly fitted.*
- *Never turn a machine cutting head to an angle that causes debris to be ejected towards the cab.*
- *Never start or continue to work a machine if people are nearby or approaching - Stop and wait until they are at a safe distance before continuing.*
- *Never attempt to use a machine on materials in excess of its capability.*
- *Never use a machine to perform a task it has not been designed to do.*
- *Never operate the tractor or machine controls from any position other than from the driving seat, especially whilst hitching or unhitching the machine.*
- *Never carry out maintenance of a machine or a tractor whilst the engine is running – the engine should be switched off, the key removed and pocketed.*
- *Never leave a machine unattended in a raised position – it should be lowered to the ground in a safe position on a level firm site.*
- *Never leave a tractor with the key in or the engine running.*
- *Never carry out maintenance on any part or component of a machine that is raised unless that part or component has been properly substantially braced or supported.*
- *Never attempt to detect a hydraulic leak with your hand – use a piece of cardboard.*
- *Never allow children near to, or play on, a tractor or machine under any circumstances.*

ADDITIONAL SAFETY ADVICE

TRAINING

Operators need to be competent and fully capable of operating this machine in a safe and efficient way prior to attempting to use it in any public place. We advise therefore that the prospective operator make use of relevant training courses available such as those run by the Agricultural Training Board, Agricultural Colleges, Dealers and McConnel.

WORKING IN PUBLIC PLACES

When working in public places such as roadsides, consideration should be paid to others in the vicinity. Stop the machine immediately when pedestrians, cyclists and horse riders etc. pass. Restart only when they are at a distance that causes no risk to their safety.

WARNING SIGNS

It is advisable that any working area be covered by suitable warning signs and statutory in public places. Signs should be highly visible and well placed in order to give clear advanced warning of the hazard. Contact the Department of Transport or your Local Highways Authority to obtain detailed information on this subject. The latter should be contacted prior to working on the public highway advising them of the time and location of the intended work asking what is required by way of signs and procedure. – ‘*Non-authorized placement of road signs may create offences under the Highways Act*’.

SUGGESTED WARNING SIGNS REQUIRED

“Road works ahead” warning sign with a supplementary “Hedge cutting” plate. “For 1 mile” or appropriate shorter distance may be added to the plate.

“Road narrows” warning sign with supplementary “Single file traffic” plate.

White on blue “Keep right” () arrow sign on rear of machine.*

** Note – this applies to UK Market machines where traffic passes to the right of a machine working in the same direction as the traffic flow. The direction, use and colour of the arrow sign will depend on the country of use and the Local Highway Authorities regulations in the locality.*

USE OF WARNING SIGNS

- *On two way roads one set of signs is needed facing traffic in each direction.*
- *Work should be within 1 mile of the signs.*
- *Work only when visibility is good and at times of low risk e.g.: NOT during ‘rush-hour’.*
- *Vehicles should have an amber flashing beacon.*
- *Ideally, vehicles should be conspicuously coloured.*
- *Debris should be removed from the road and path as soon as practicable, and at regular intervals, wearing high visibility clothing and before removing the hazard warning signs.*
- *Collect all road signs promptly when the job is completed.*

Although the information given here covers a wide range of safety subjects it is impossible to predict every eventuality that can occur under differing circumstances whilst operating this machine. No advice given here can replace ‘good common sense’ and ‘total awareness’ at all times but will go a long way towards the safe use of your McConnel machine.

VEHICLE/ TRACTOR PREPARATION

We recommend vehicles are fitted with cabs using safety glass windows and protective guarding when used with our machines.

Fit Operator Guard (part no. 73 13 324) using the hooks provided. Shape mesh to cover all vulnerable areas.

Remember the driver must be looking through mesh and/or polycarbonate glazing when viewing the flail head in any working position - unless the vehicle/ cab manufacturer can demonstrate that the penetration resistance is equivalent to, or higher than, that provided by mesh/polycarbonate glazing. If the tractor has a roll bar only, a frame must be made to carry both mesh and polycarbonate glazing. The operator should also use personal protective equipment to reduce the risk of serious injury such as; eye protection (*mesh visor to EN1731 or safety glasses to EN166*), hearing protection to EN352, safety helmet to EN297, gloves, filter mask and high visibility clothing.

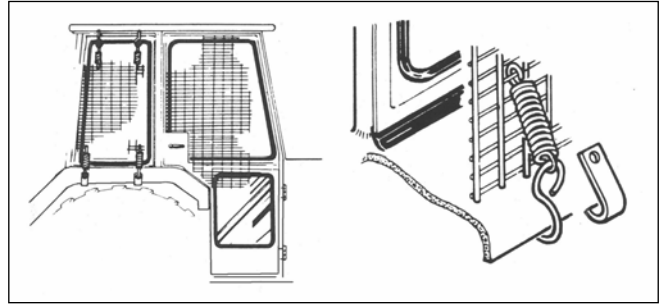

Vehicle Ballast: It is imperative when attaching 'third-party' equipment to a vehicle that the maximum possible stability of the machine and vehicle combination is achieved – this can be accomplished by the utilisation of 'ballast' in order to counter-balance the additional equipment added.

Front weights may be required for rear mounted machines to place 15% of total outfit weight on the front axle for stable transport on the road and to reduce 'crabbing' due to the drag of the cutting unit when working on the ground.

Rear weights may be required to maintain a reasonable amount of rear axle load on the opposite wheel from the arms when in work; for normal off-ground work i.e. hedge cutting this should be 20% of rear axle weight or more for adequate control, and for ground work i.e. verge mowing with experienced operators, this can be reduced to 10%.

All factors must be addressed in order to match the type and nature of the equipment added to the circumstances under which it will be used – in the instance of Power Arm Hedgecutters it must be remembered that the machines centre of gravity during work will be constantly moving and will differ from that during transport mode, therefore balance becomes critical.

Factors that effect stability:

- Centre of gravity of the tractor/machine combination.
- Geometric conditions, e.g. position of the cutting head and ballast.
- Weight, track width and wheelbase of the tractor.
- Acceleration, braking, turning and the relative position of the cutting head during these operations.
- Ground conditions, e.g. slope, grip, load capability of the soil/surface.
- Rigidity of implement mounting.

Suggestions to increase stability:

- Increasing rear wheel track; a vehicle with a wider wheel track is more stable.
- Ballasting the wheel; it is preferable to use external weights but liquid can be added to around 75% of the tyre volume – water with anti-freeze or the heavier Calcium Chloride alternative can be used.
- Addition of weights – care should be taken in selecting the location of the weights to ensure they are added to a position that offers the greatest advantage.
- Front axle locking, check with tractor manufacturer.

The advice above is offered as a guide for stability only and is not a guide to vehicle strength. It is therefore recommended that you consult your vehicle manufacturer or local dealer to obtain specific advise on this subject, additionally advice should be sought from a tyre specialist with regard to tyre pressures and ratings suitable for the type and nature of the machine you intend to fit.

FITTING

TRACTOR SELECTION

Linkage requirements

The Power Arms will fit almost any tractor with a category II linkage.

Linkage isolation

A linkage isolation facility is necessary for Si models only.

Check chains/stabilisers

Check chains or stabiliser bars must be fitted and tightened.

Tractor relief valve

For Si models only tractor relief valve must be set above 2000 psi (140 bar)

Tractor hydraulic flow rate

Hydraulic flow rates are not crucial for Si models

P.T.O. shaft

Tractor must be equipped with live drive independent PTO shaft to enable forward movement to be halted while the flail head continues to operate.

TRACTOR PREPARATION

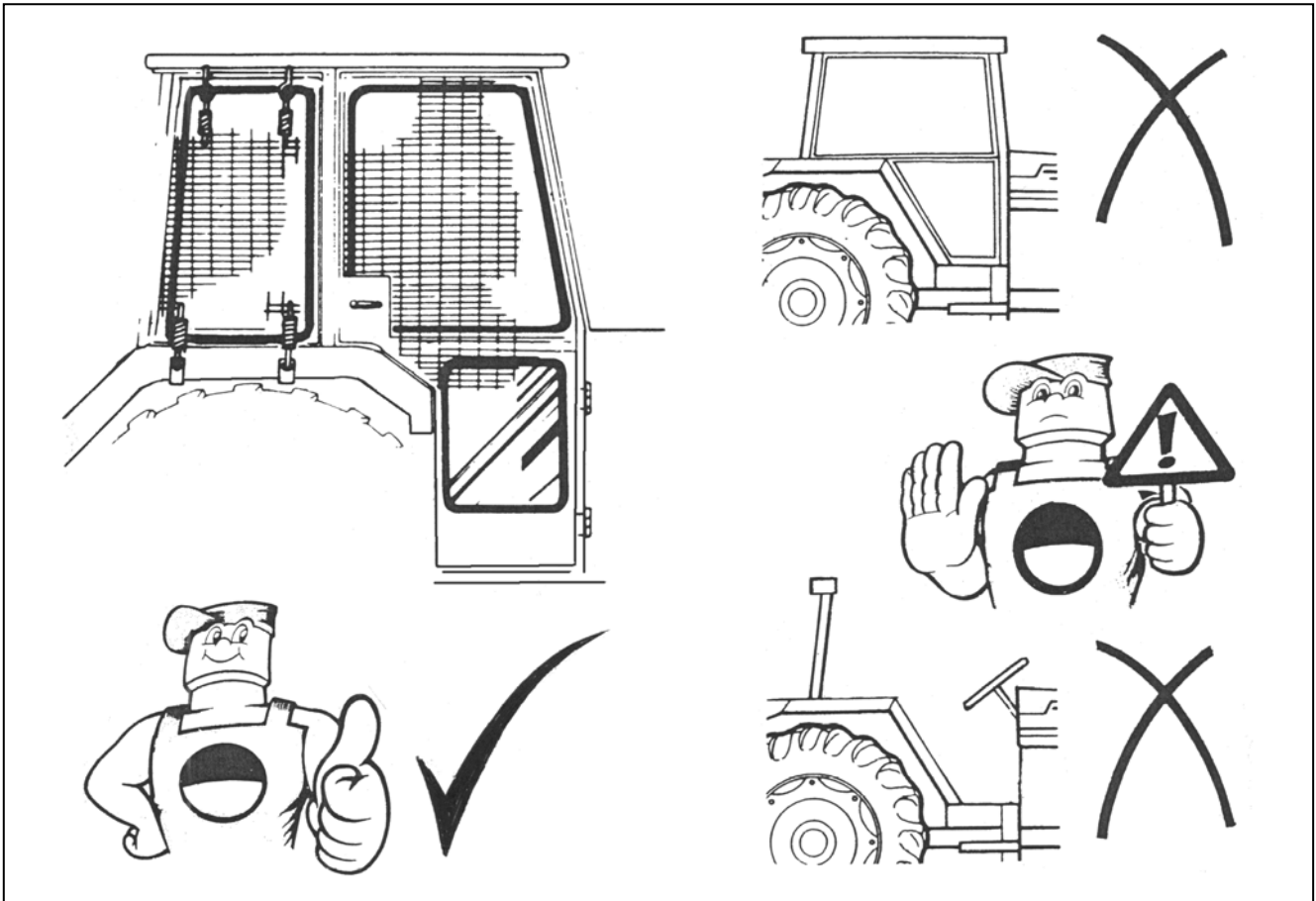

Fitting Operator Guard

Use tractor with safety glass windows and fit **Operator guard** (part no. 73 13 324) using the hooks provided.

Shape mesh to cover all vulnerable areas.

Remember the driver must be looking through mesh at the flail head in any working position.

If the windows are not laminated safety glass polycarbonate glazing must also be fitted.

If the tractor has a roll bar only, a frame must be made to carry both mesh and polycarbonate glazing.

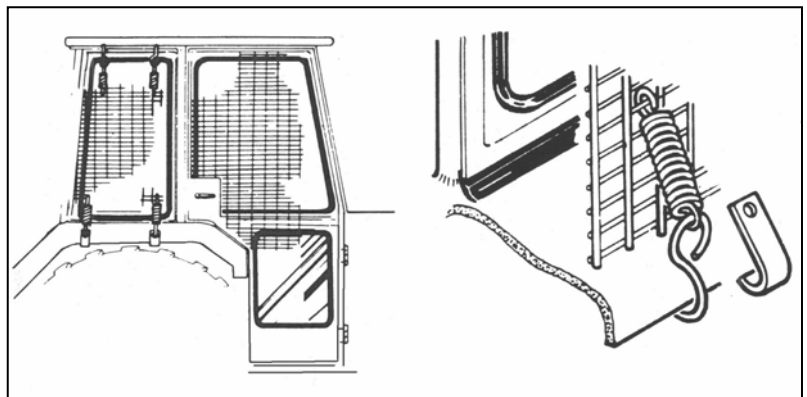

Wheel Width

Set wheel widths as wide as possible – see page 8.

Ballast Weight

Add ballast weight whenever necessary within the tractor manufacturers recommended limits to ensure maximum stability under all working conditions – see page 8.

Lift Links

Adjust lift links until they are equal length.

CLOSED CENTRE CONVERSION KIT - (Part No. 8130059)
Semi Independent Models only

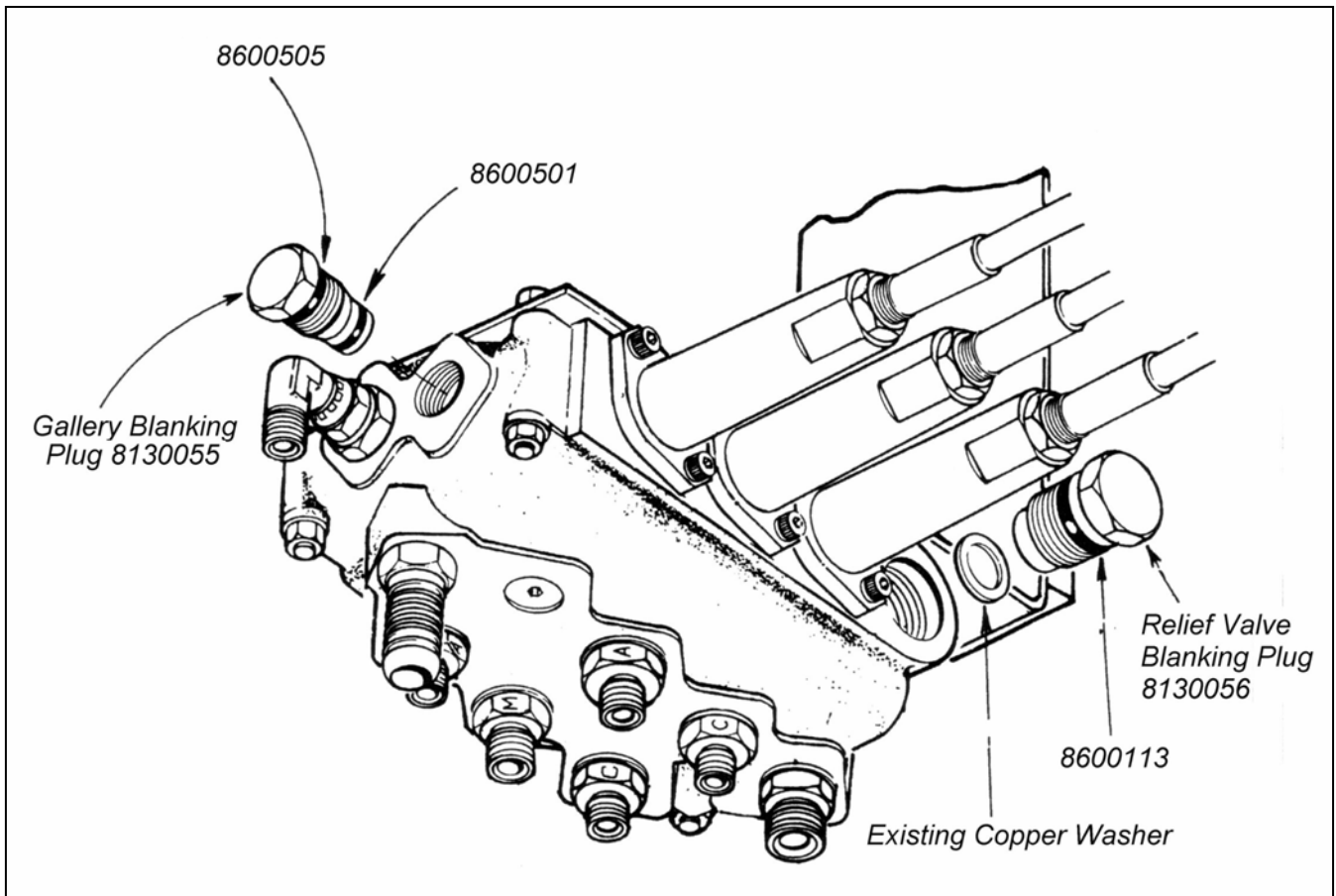

A control valve conversion kit (Part No. 8130059) consists of a relief valve-blanking plug, which should be installed in place of the existing relief valve, and a pressure gallery blanking plug, which is installed in place of the standard blanking plug at the valve outlet end next to the lift ram gland connection.

NOTE: Take care when extracting the relief valve not to damage the copper sealing washer, as it is to be re-used.

When working in this mode the tractor's pressure control valve must not exceed 2500 P.S.I (170 Bar).

OIL REQUIREMENTS

Tank

Fill the reservoir to approximately 2" (50mm) below the top of the tank. The capacity is approximately 200 Litres (44 imp. Gallons).

Do not overfill.

| Supplier | Cold or temperate climate | Hot climate |
|-----------------|---|--|
| CASTROL | <i>Agricastrol hydraulic oil Hy-spin AWS 46</i> | <i>Hy-spin AWS 68</i> |
| SHELL | <i>Tellus 46</i> | <i>Tellus 68</i> |
| MOBIL | <i>D.T.E. 25</i> | <i>D.T.E. 26</i> |
| ESSO | <i>Nuto 'H' ou 'A' 46</i> | <i>Nuto 'H' or 'A' 68</i> |
| TEXACO | <i>Rando HD 46</i> | <i>Rando D 68</i> |
| GULF | <i>Hydrasil 46</i> | <i>Hydrasil 68</i> |
| B.P. | <i>Energal HLP 46</i> | <i>Energal HLP 68</i> |
| DALTON | <i>Silkolene Dove 46 or Derwent 46</i> | <i>Silkolene Dove 68 or Derwent 68</i> |
| ELF | <i>Hydrelf 46</i> | <i>Hydrelf 68</i> |

Gearbox

Check the gearbox oil level – on level ground gearbox should be filled until oil 'dribbles' out of the level plug. Top up if required with SAE 30/50 Universal Tractor Oil.

DELIVERY

The machine is delivered in a partially dismantled condition. To make ready for attachment to the tractor it will be necessary to:

Select a hard level surface

- * Cut the banding straps and remove loose items. On mid-cut machines the front hood must be bolted to the flail head.
- * Fill the reservoir to capacity with oil selected from the chart on the previous page.
- * Remove the lifting plate and re position the reach ram rod pin with the pin tail in its locating hole.
- * Remove and discard the transport strap connecting the flail head to the frame.

ATTACHMENT TO TRACTOR

- * For **electric controlled models only** the base end pin of the angling ram and the rod end pins of the lift and reach rams must be removed.
- * On **Si models only** reverse the tractor up as closely as possible. Fit suitable return connection to the tractor and connect the return hose before connecting the supply hose to the tractors external services point with a suitable self-seal coupling.
- * **Ensure** that lift ram tap (and reach ram tap on mid-cut machines) are fully open.
- * With the aid of a crowbar prise the flail head sideways to allow the tractor to be reversed up

For cable controlled models only assistance will be needed to simultaneously select "Reach out" and "angle down" to allow the oil to flow whilst the arms are being moved.

WARNING

As a safety precaution to prevent the possibility of the flail head slipping sideways and the arm collapsing on the fitter as he is prying the head sideways, a loop of strong rope or wire, with sufficient slack to allow the required flail head movement should connect the frame and dipper. This will then act as an arrestor in the event of this happening. Leave in position until attachment is complete.

Adjust tractor drop arms to enable the draft links to lower to within 15" (375mm) of the ground.

Remove the top link and machine yoke completely.

Reverse the tractor squarely to the front of the machine, engage draft link pins and secure.

Attach yoke to the top hitch position on the tractor ensuring the lug for the top link is uppermost.

Unlimber the machine controls and fit into the tractor cab – refer to pages 16 & 17.

Install the top link between yoke and upper hitch position on the machine. - If necessary fitting Cat. 1 sleeves into the ball ends of the top link.

- * Raise the machine on its three point linkage until the PTO shaft and the gearbox stub shaft are as near as possible in a straight line.

* At this point check that the welded in pins between the jaws of the yoke are tightly against the top of the mounting rail - If the welded in pins are not in contact with the rail the machine must be lowered to the ground, the next hole on the yoke top link lug selected, the machine raised again and contact checked. Repeat again in the third hole if necessary. *On subsequent fitting to the same tractor the hole selected is always used.*

Secure the yoke with the locking pins and spring cotters provided ensuring that they engage in matching holes in the mounting rails.

Lower the quadrant lever so that the machines weight is taken by the yoke - Adjust the top link to bring the pillar upright.

* Reposition the eccentric collars in the holes immediately behind the yoke and adjust until both collars each side abut against the face of the yoke plates. Tighten in position. *These collars act as stops for the yoke during subsequent fitting to the same tractor. If the tractor used is changed new collar positions will need to be worked out following the previous procedure.*

WARNING

The quadrant lever or machine controls must be operated from the tractor seat. During this operation ensure no one is standing on or amongst the linkage arms or bars.

* Measure the PTO drive shaft length as shown in the diagram below and subtract 2 inches (50mm).

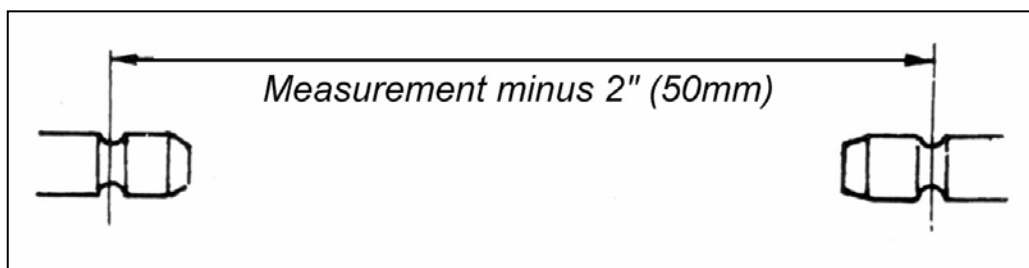

* *This measurement which is the fully closed final length of the PTO drive shaft measured button to button should be taken carefully before the PTO drive shaft and guards are shortened to suit by cutting off both the driving and driven members of the tube by an equal amount. Accurate measurement is important on some close-coupled tractors to ensure maximum engagement during operation.*

Fit the P.T.O. shaft in position - ensure that the collar locking devices on the P.T.O, shaft are fully engaged and wrap the torque chain around any convenient point to prevent the shaft guard from rotating.

Check that the rotor control valve is in the stop position (*T.i. models only*).

* For electric controlled machines only engage the P.T.O. (see page 18) and select "Lift down" until the lift ramrod together with its pin can be re-assembled in position. Similarly selecting "Reach out" and "Angle down" will enable the respective ram rods and pins to be replaced.

Carry out final adjustment of the tractor lift arm-leveling box to bring the main frame horizontal. This should be checked with the arms at approximately half reach with the flail head clear of the ground.

* Remove the rope arrestor loop.

Carry out final adjustment of the tractor lift arm-leveling box to bring the main frame horizontal. This should be checked with the arms at approximately half reach with the flail head clear of the ground.

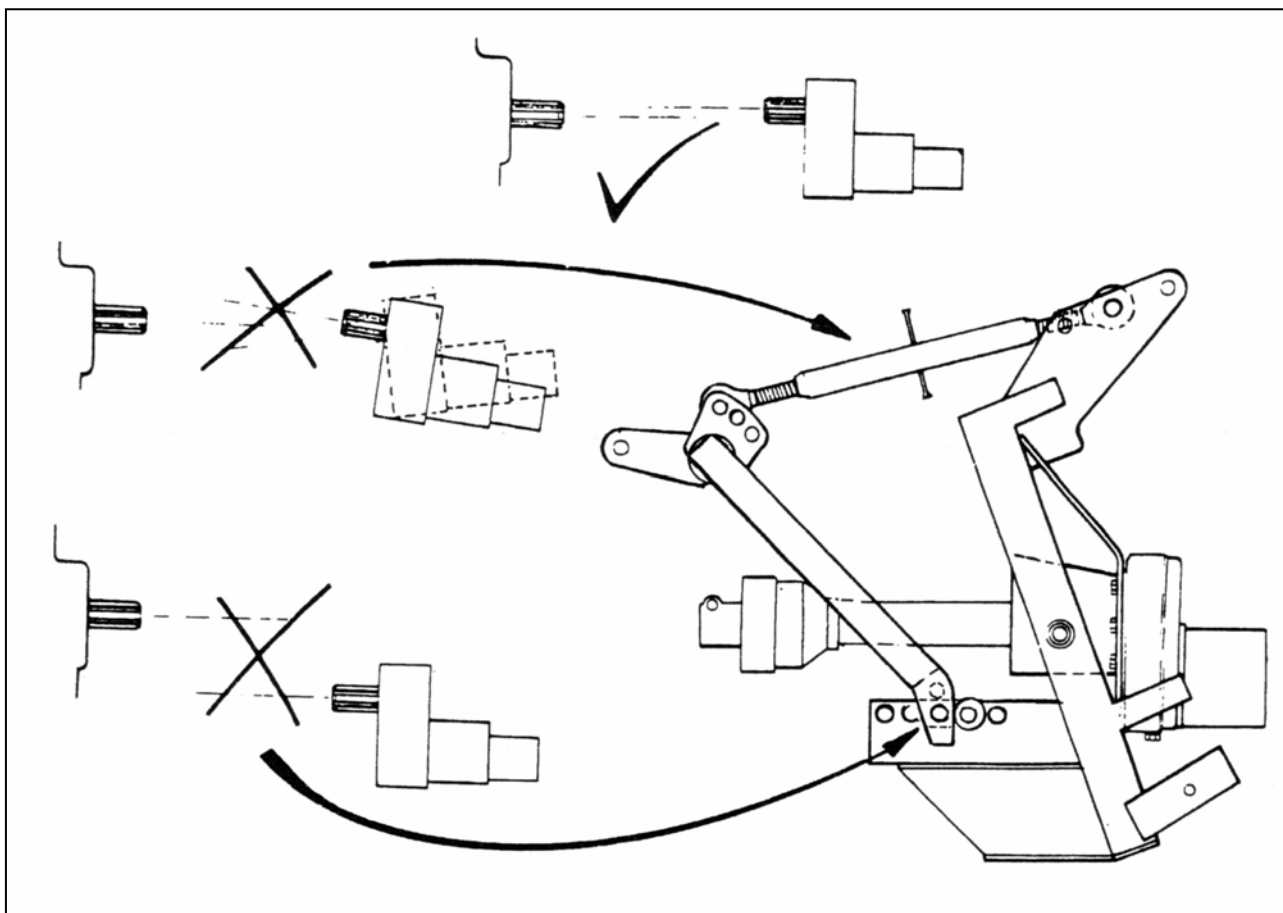

Remove the parking feet, turn inward 90 degrees and re-locate in their housings. Carefully operate the machine through its full range of movement whilst checking that the hoses are not strained, pinched, chaffed or kinked and that all movements are functioning correctly.

* Assemble the cover plate and the hedge hood into position

Fold the machine into the transport position (*refer to page 24*)

The machine is now ready to proceed to the work site.

This procedure is for initial attachment only, for subsequent attachment paragraphs marked * do not apply.

FITTING CONTROL UNIT IN CAB

A bracket is clamped between the seat runners and their mounting base. Attached to this is a stalk, which carries the control units. Modification to either may be necessary to achieve a comfortable working position.

On tractors other than the quiet cab models the stalk can be bent and bolted to the mudwing or the cladding of the cab ensuring that no structural member of the safety frame is drilled. See 'B'.

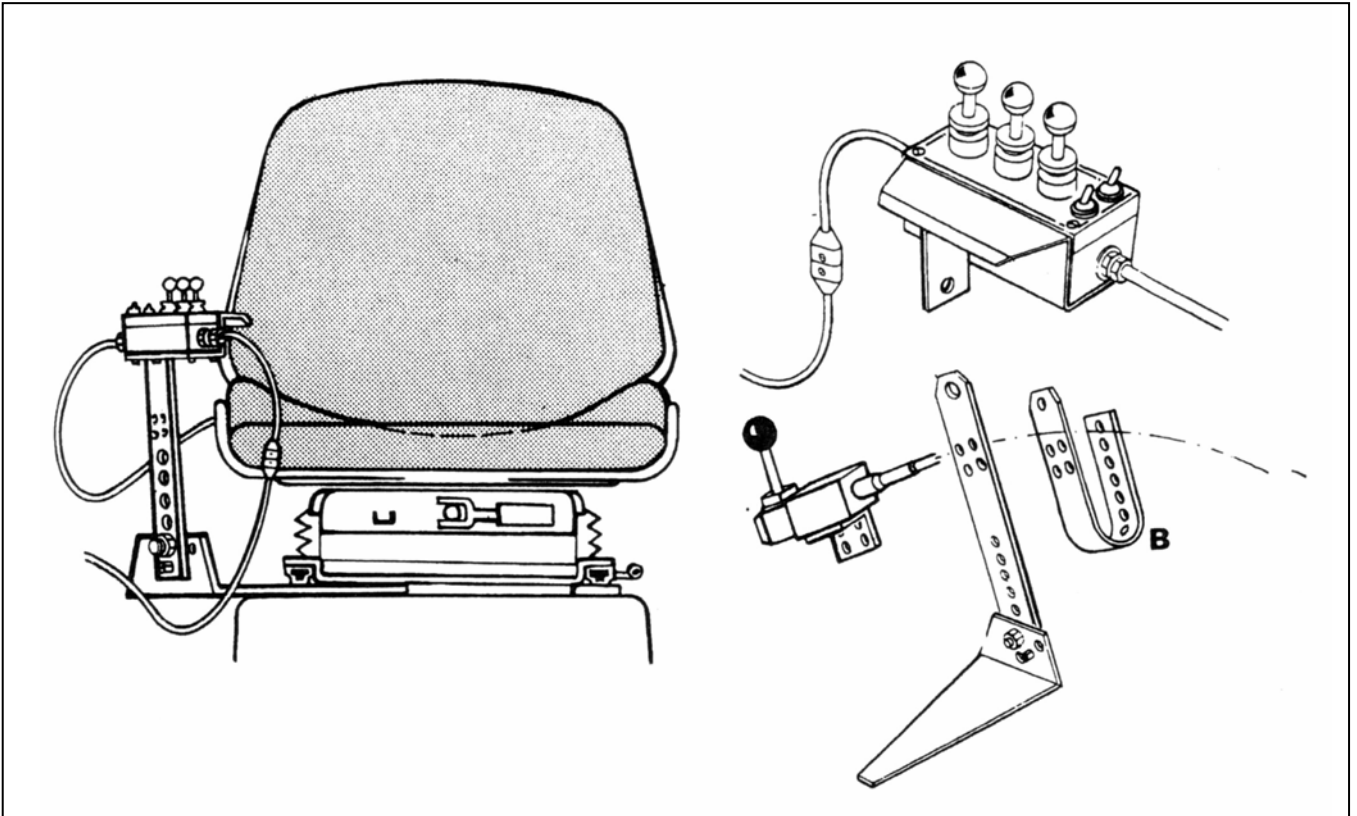

Electric controlled models only

The supply cable with the disconnected plug should be connected to the tractors electrical system preferably at the fuse box or the ignition switch where it can be switched off with the tractors isolation key.

The control is 12 volt D.C. operated: the brown lead is Positive and the blue lead is Negative.

The control lever for the cable operated Flail rotor on/off valve is then bolted into position on the mounting stalk.

Cable controlled models

The control unit is bolted to an angled mounting bracket in either a transverse or longitudinal position thus giving a variety of mounting positions, which in conjunction with the flexibility of the mounting pillar will enable a satisfactory working position to be achieved.

In deciding the final position of the control box remember not to exceed the minimum acceptable bend radii of 8" for the cables.

The handles may be screwed into alternative holes in the levers to give an 'in line' installation should it be desirable.

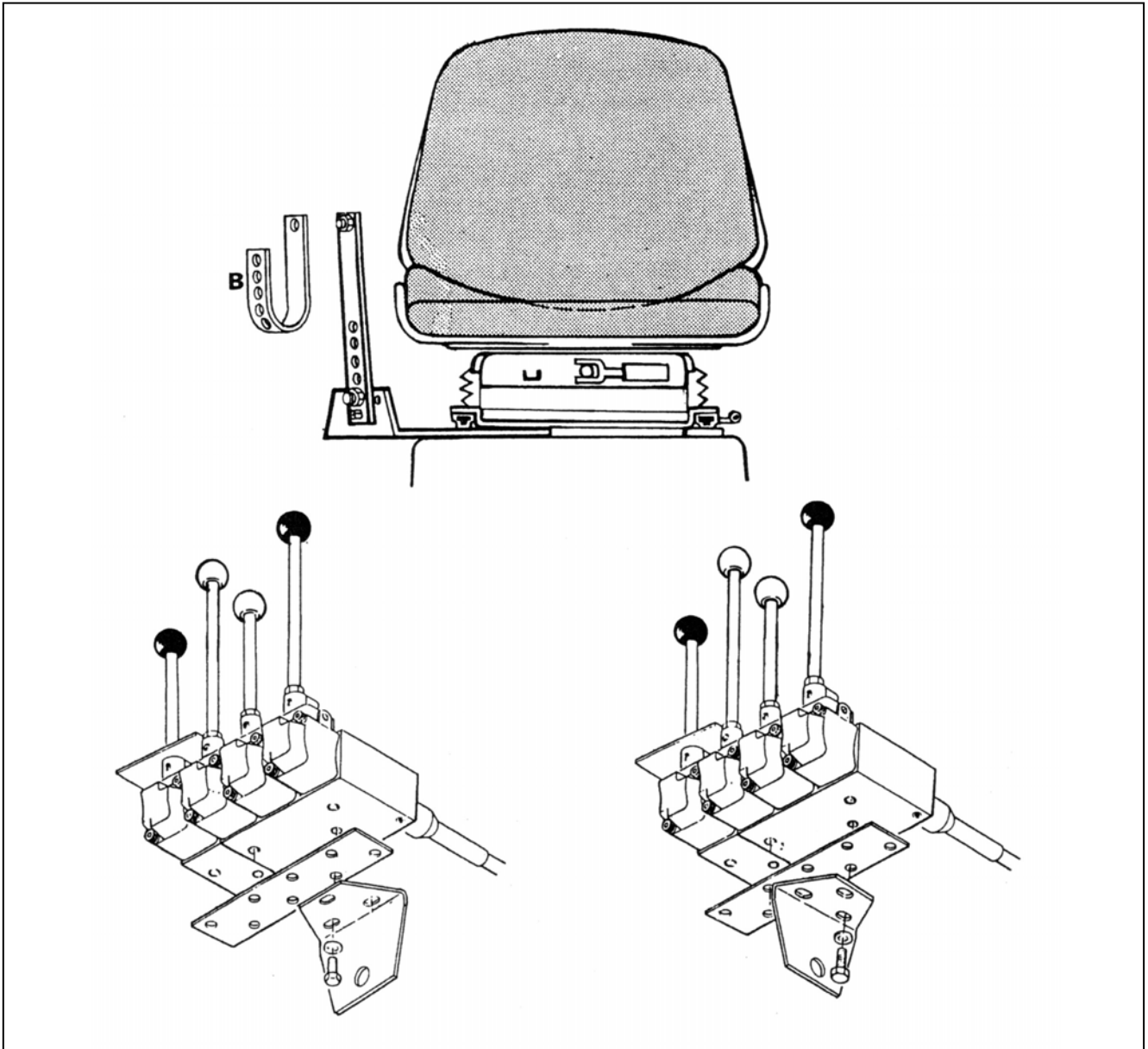

RUNNING UP PROCEDURE

Ti models only

Ensure that the rotor control valve is in "**STOP**" position, start tractor, engage P.T.O. allow the oil to circulate through the return line filter for about 5 minutes without operation of the armhead control lever.

Operate the armhead levers through their complete range ensuring that all movements are functioning correctly.

Place the flail head at a safe attitude and move the rotor control to "START" position. After initial fluctuation the rotor should settle to a steady speed. Increase P.T.O. speed to approximately 360 rpm. and run for a further five minutes before disengaging and stopping tractor.

Check the hose runs and observe that they are free from any pinching, chafing straining or kinks. Re-check the oil level in the tank and top up as necessary.

Si models only

Ensure P.T.O. lever is in neutral position, and isolate tractor hydraulic linkage. Start tractor and select external service supply. Allow the tractor to run for several minutes before attempting to operate any of the machine control levers.

On operating move the levers through their complete range ensuring that all movements are functioning correctly.

Check the tractor rear axle oil level and top up if necessary.

Place the flail head at a safe attitude and bring tractor engine revolutions to 1000 rpm. Engage P.T.O. and allow the rotor to run for several minutes. Do not leave the tractor cab or allow anyone to approach the flail head at this time.

CAUTION

Do not allow the pump to continue working if the rotor does not turn. Overheating and serious damage to the pump can be caused in a very short time.

After running up the machine increase P.T.O. speed to approximately 360 rpm. and run for a further five minutes to allow the oil to circulate through the return line filter before disengaging the P.T.O. and stopping tractor.

Check the hose runs and observe that they are free from any pinching, chafing, straining or kinks. Re-check the oil level in the tank and top up as necessary.

REMOVAL FROM TRACTOR

DANGER

READ CAREFULLY BEFORE COMMENCING TO REMOVE THE MACHINE FROM THE TRACTOR

**THE ORDER OF THE FOLLOWING STEPS MUST BE FOLLOWED EXACTLY
DISCONNECTING THE TOP LINK MUST BE THE LAST OPERATION PRIOR TO
DRIVING THE TRACTOR AWAY FROM THE MACHINE**

WARNING

**Do not operate quadrant lever or machine controls through the rear cab window whilst standing on or amongst linkage components.
Always seek assistance.**

Select a firm level site for parking the machine.

Remove the parking feet, turn through 90° to face towards the ground and re-locate in the housing.

Unscrew the lift ram tap and with the machine at approximately half reach in normal working position, *i.e. not broken back*, operate the hydraulic service until the flail head roller is horizontal and level with the feet on the main frame.

Disengage tractor PTO and remove.

Disconnect stabiliser bars or loosen check chains as applicable.

Unbolt the control unit from the mounting pillar, remove from tractor cab and stow the levers or switchbox clear of the ground, **On Si models only** disconnect the supply and return hoses and stow with hose ends clear of the ground.

Raise the machine on the tractors linkage to take the weight off the yoke and remove the lower yoke pins.

Lower the tractor draft links and place machine firmly on the ground.

Remove draft links and the top link from the machine, drive tractor forward and remove yoke.

Blank off the end of the return hose with a plug or small plastic bag if a self seal coupling is not fitted.

STORAGE

If machine is to be left standing for an extended period of time, lightly coat the exposed portions of the ramrods with grease. Subsequently this grease should be wiped off before the rams are next moved.

If the machine has to be stored outside tie a piece of tarpaulin or canvas over the control assembly **do not** use a plastic bag this could lead to rapid corrosion of the control unit.

OPERATION

Material Thickness Cutting Limitations

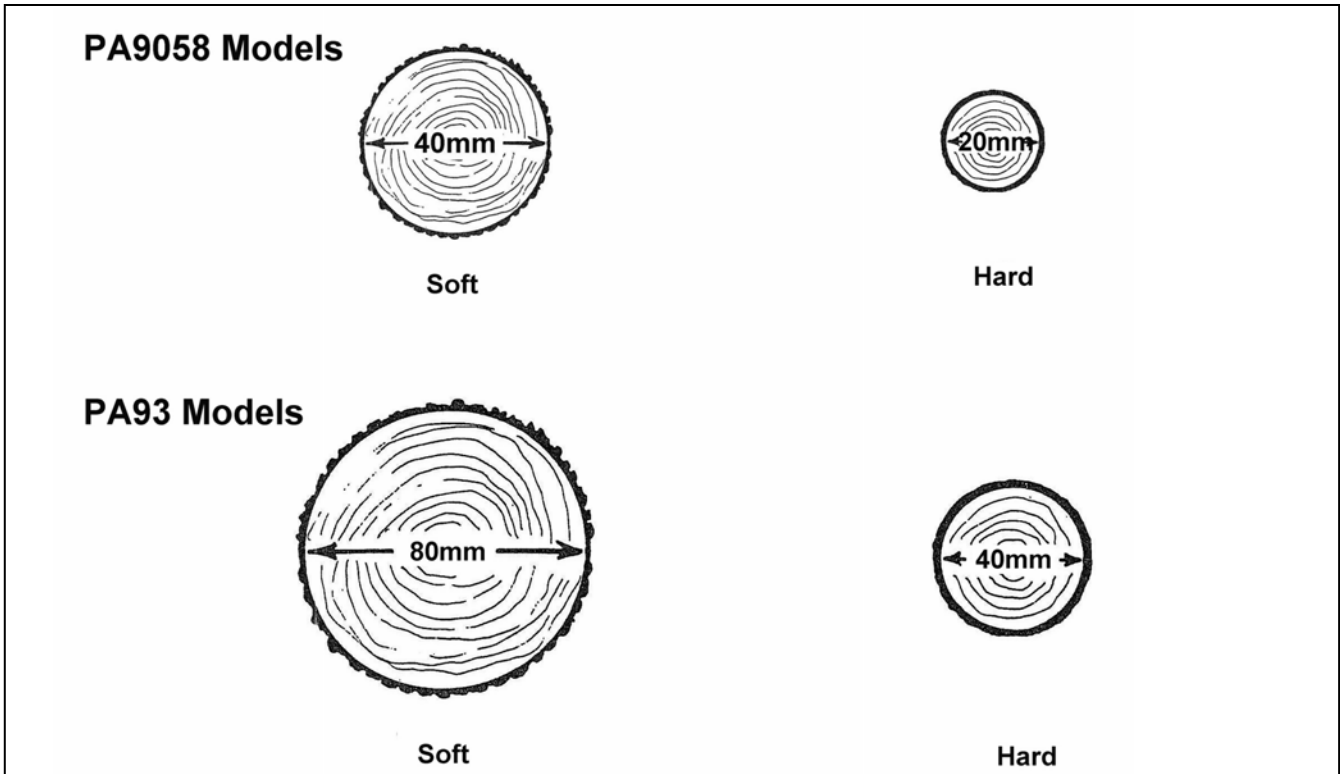

OPERATOR GUARD – Refer to page 8.

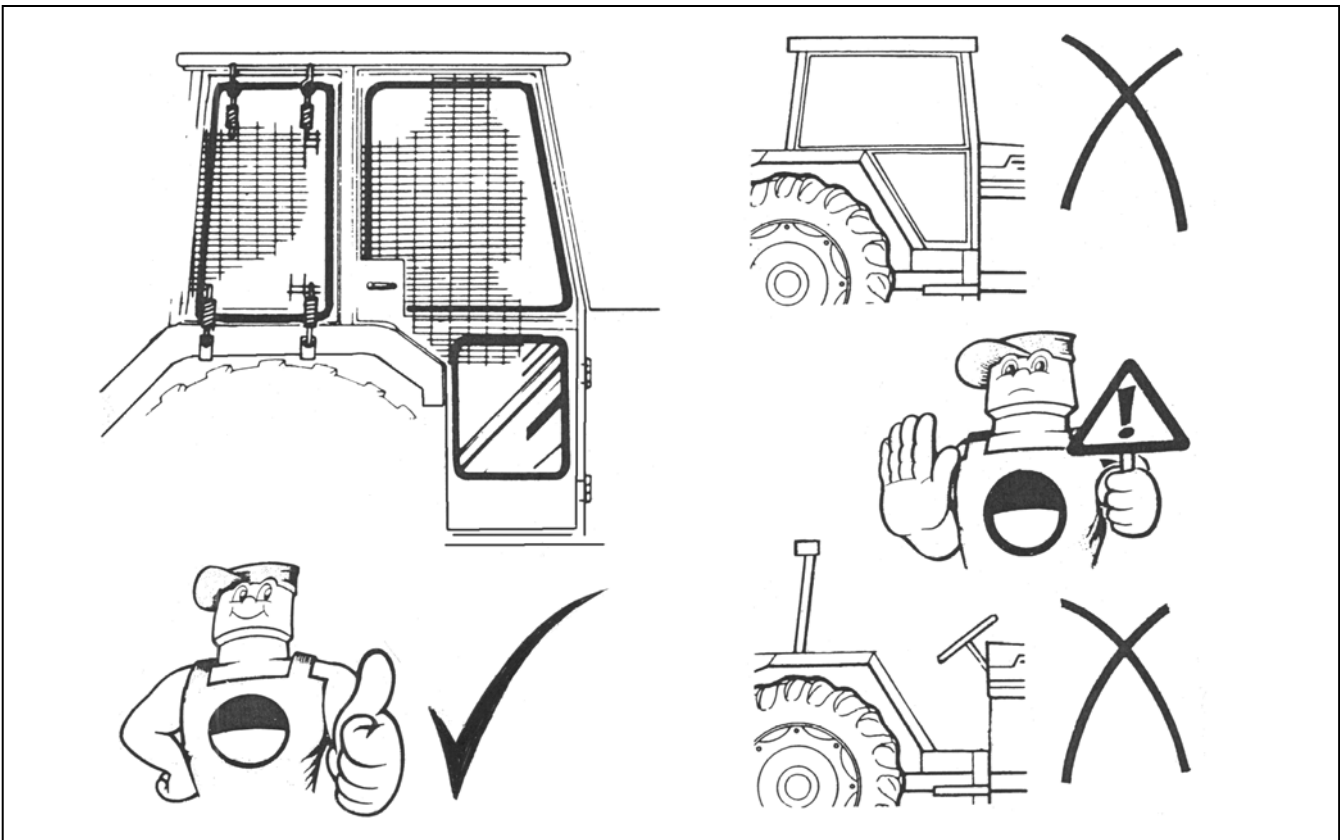

PREPARATION

Read the book first.

Practice in an open space without the rotor running until familiar with controls.

CAUTION: Take care when working with the flail head close in as it can hit the tractor.

TRACTOR CONTROLS

NOTE: For Si Models only the tractors linkage will need to be isolated.

MACHINE CONTROLS

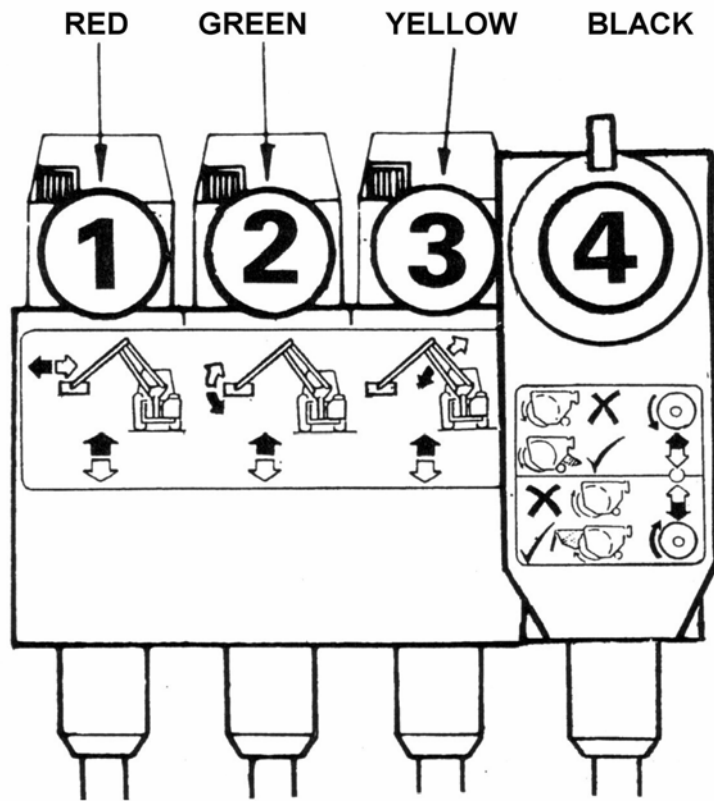

PA93 Si and PA9058 Si - 1, 2 and 3

PA93 Ti and PA9058 Ti - 1, 2, 3 and 4

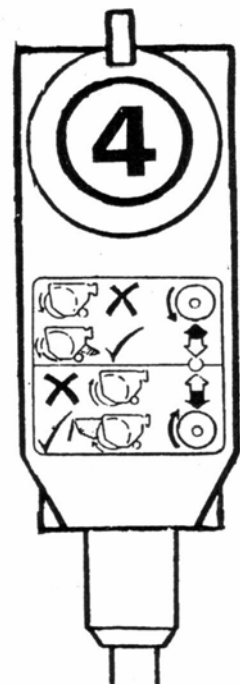
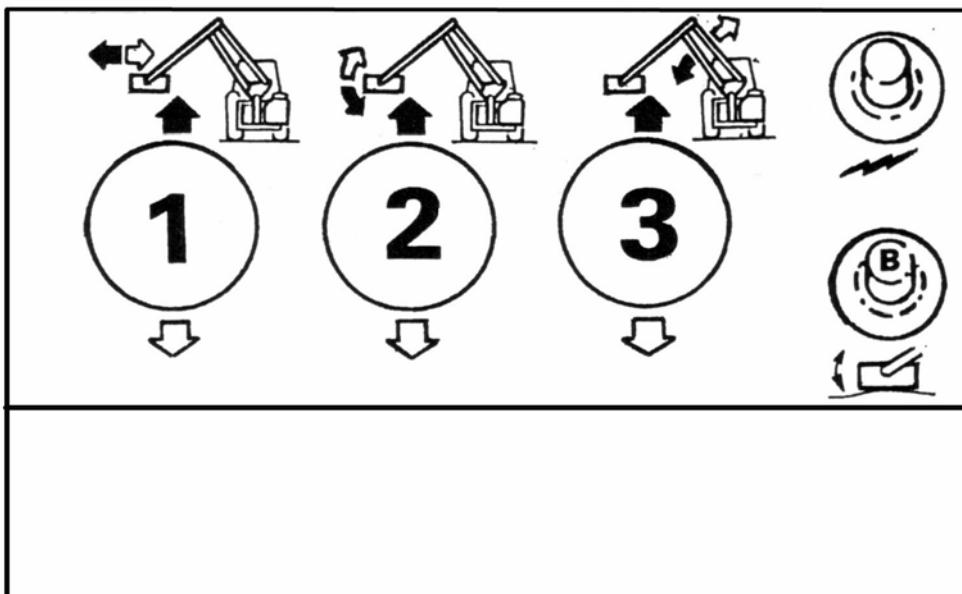

PA93E, PA93E Super and PA9058E

ARM CONTROLS

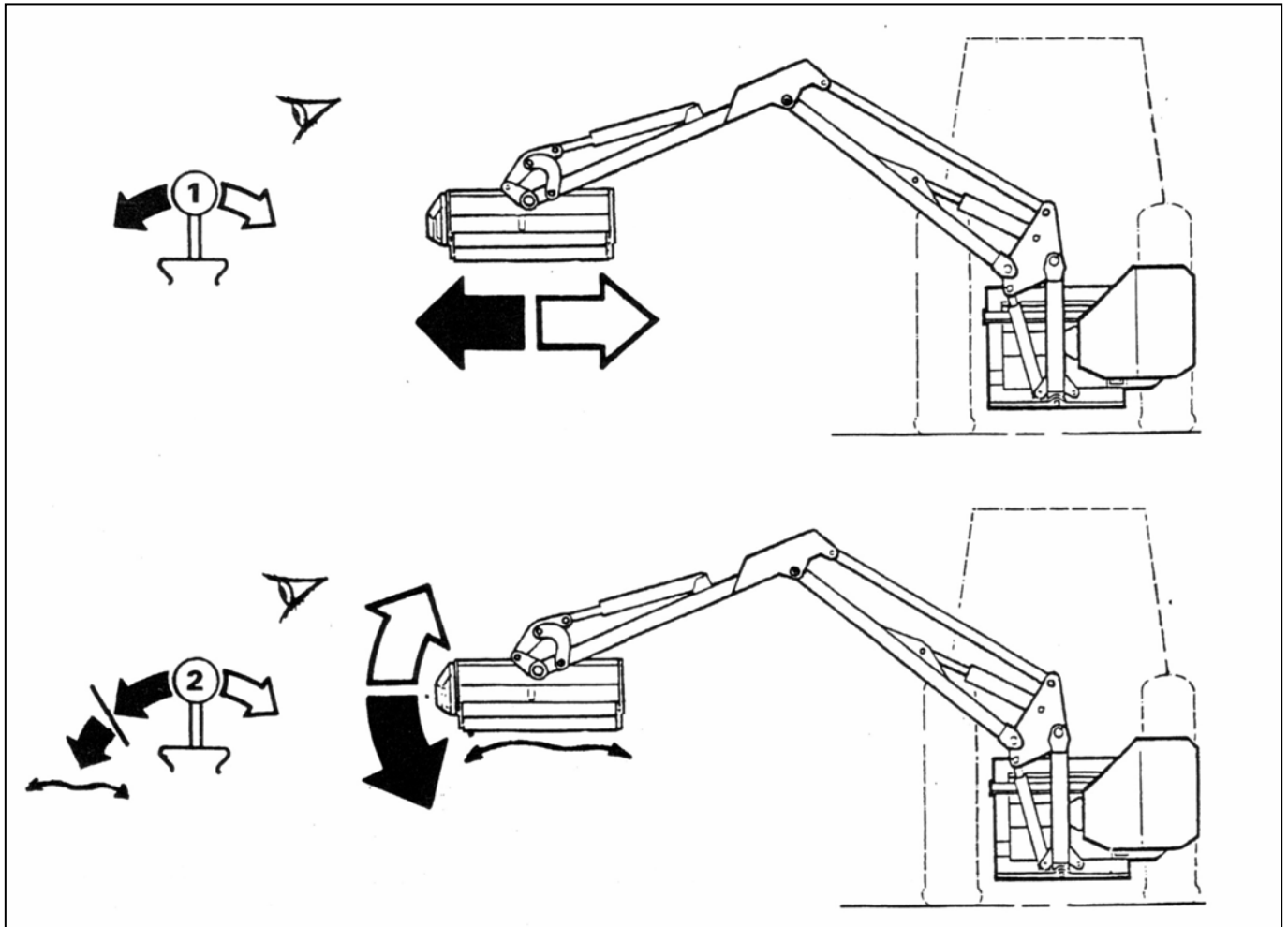

HEAD ANGLE FLOAT – PA9058 Si & Ti only

An angle 'float' position can be selected which allows the flail head to automatically angle itself to the contours of the ground. To obtain this position the control lever must be pushed away from the operator beyond its normal range until it locks into the float position. To return to normal operation the float position must be manually de-selected.

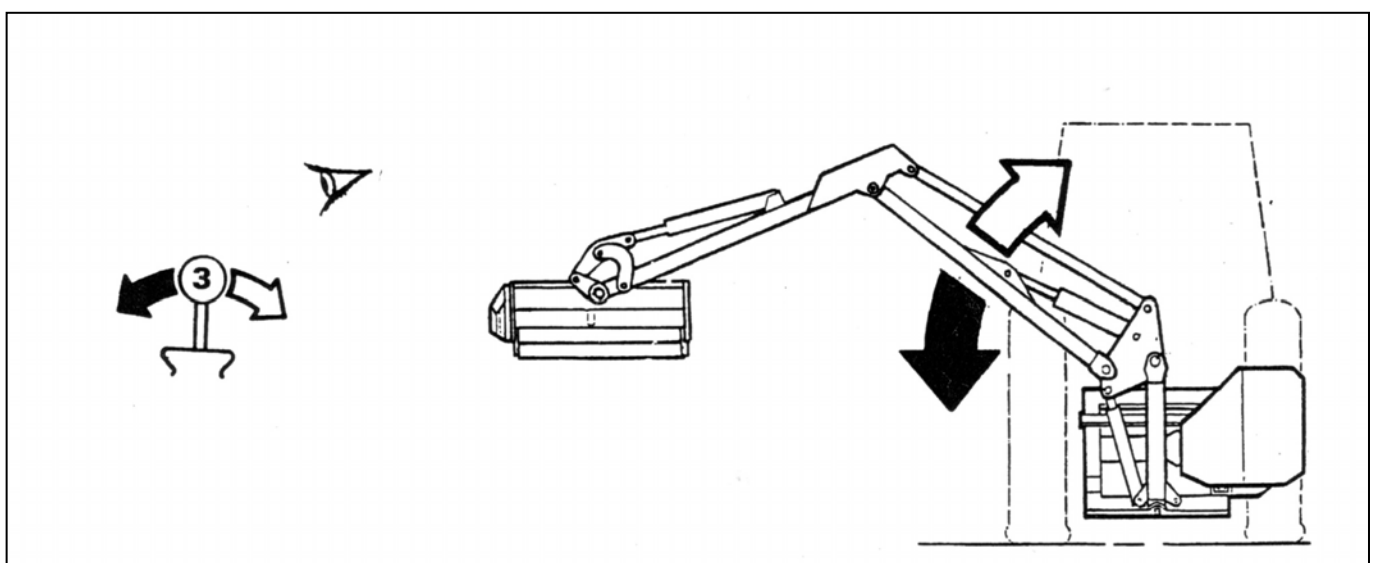

ROTOR CONTROLS

Ti machines only

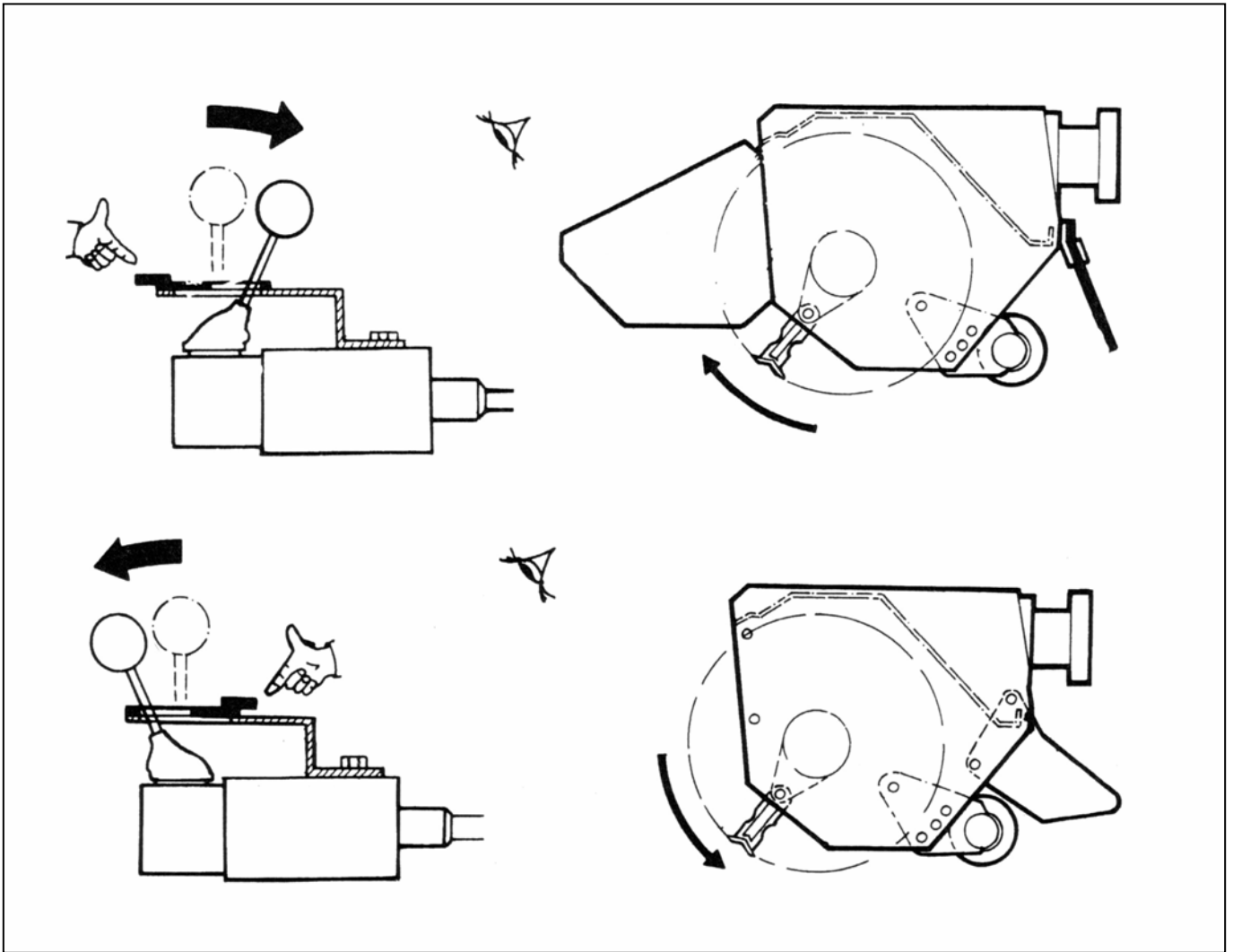

Si machines only

Rotor ON/OFF is controlled by operation of the tractors PTO lever.

To START rotor:

Bring tractor engine revs up to 1000 rpm.

Engage PTO.

To STOP rotor:

Disengage PTO. – ***Do not leave tractors seat until the rotor is stationary.***

MOVING INTO THE TRANSPORT POSITION

PA93 Standard Arm models only

When transporting on the highway the arms should be latched securely in the broken back position and the white tap on the lift ram screwed fully in.

To achieve this position angle the flail head and place one corner of it on the ground. Raise the latch; drive forward and simultaneously select "lift down". Release the latch and check that it is fully engaged. Raise and fold the machine into the transport position taking care not to hit the tractor cab or mudwing. Screw the lift ram in fully to prevent any droop.

MOVING FROM THE TRANSPORT POSITION

PA93 Standard Arm models only

Unscrew the lift ram tap fully. Lower the flail head flat to the ground and release the transport latch, if it does not release take the weight off the latch by easing the tractor forward slightly. The working position can be achieved by either reversing the tractor or by operating the lift ram to raise the head which allows the breakaway mechanism to position the flail head for work.

MOVING INTO THE TRANSPORT POSITION

PA93 Midcut Arm and PA9058 models only

Select rotor off and wait until the rotor has stopped rotating.

Fold the arms in until the flail head is vertical and parked as tightly as possible alongside the cab with the flails facing outwards.

Note:

Leave adequate clearance to prevent the flail head hitting the tractor during transport.

Close the lift ram tap. Close reach ram tap on PA93 mid cut arms only.

MOVING FROM THE TRANSPORT POSITION

PA93 Midcut Arm and PA9058 models only

Open the lift ram tap. Open the reach ram tap on PA93 mid cut arms only.

Unfold the arms and position the flail head in the work position.

Select rotor on.

ENGAGING DRIVE

a) Ti models only

Ensure that the rotor control lever is in the 'Stop' position before engaging the PTO shaft. Allow the oil to circulate for a minute or so before operating the armhead levers. Position the flail head in a safe position, increase the engine speed to a high idle and move rotor control lever to 'START'. After initial surging the rotor will run at an even speed.

b) Si models only

Place the flail head at a safe attitude and bring the tractor engine revs to 1000rpm. Engage the PTO and slowly increase revs until operating speeds are attained.

ROTOR OPERATING SPEED

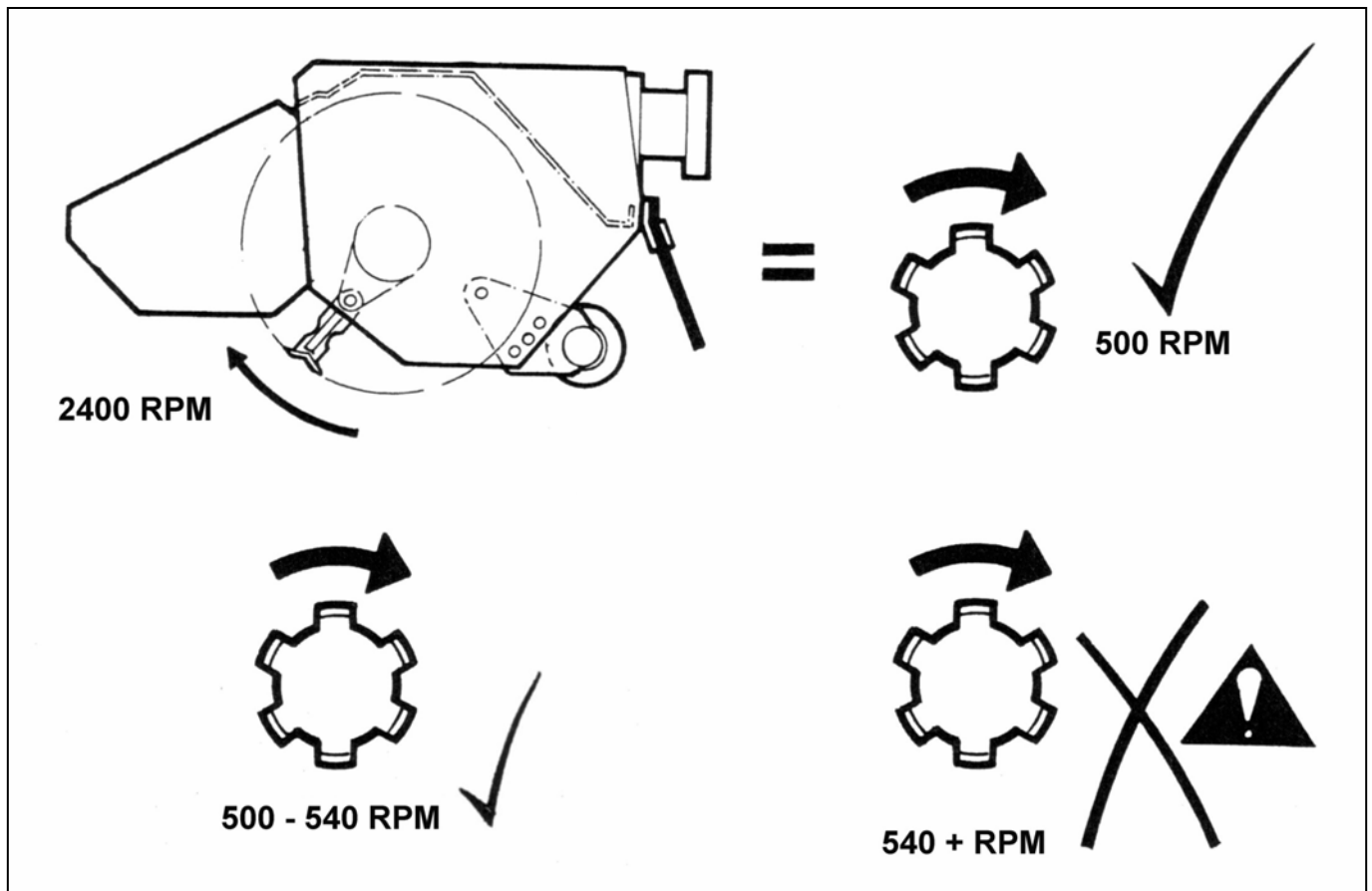

TRACTOR FORWARD SPEED

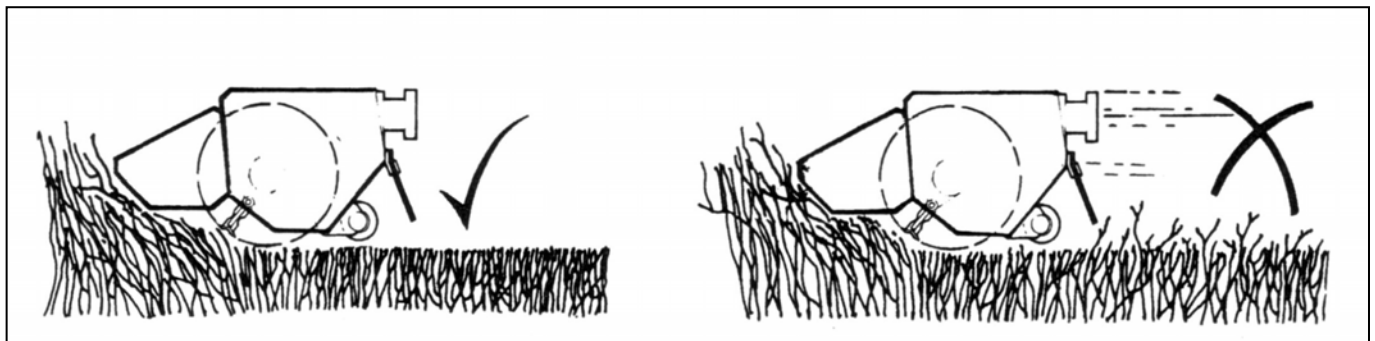

HIGHWAY WORKING

Local highway working regulations must be observed at all times.

WARNING

It is the operators' responsibility to observe these regulations and to ensure that all bystanders are kept at a safe distance at all times.

GENERAL WORKING PRACTICES

It is the operators' responsibility to develop, and adhere to, safe working practices.

ALWAYS:

Be aware of hazards in the vicinity

Make sure all guards are in position and in good condition.

Disengage P.T.O. before stopping the engine.

Wait until the flail has stopped running before leaving the tractor seat.

Disengage the P.T.O. and stop the tractor engine before making any adjustments.

Check frequently that all nuts and bolts are tight.

Keep bystanders at a safe distance.

BREAKAWAY

An automatically resetting, power assisted, gravity breakaway system protects the machine when an obstruction is encountered.

The spring pre-load is factory set and non-adjustable.

Breakaway reset forces are absorbed by a pre-tensioned hollow rubber spring unit.

The breakaway geometry is such that there is a possibility of an unstable condition occurring when in the broken back position at full height. When operating in conditions where there is any likelihood of this happening e.g. when cutting high hedges on sloping ground the latch must always be in the lowered position. Where it acts as an abutment stop.

AUTO HEAD CONTROL

PA93E AHC models only

An automatic function which maintains the flail head angle at the chosen setting during normal 'Lift' and 'Reach' adjustments.

Note: *The performance of the function deteriorates when working within half a metre of full reach.*

Should 'Head angle float' be selected the auto head control feature ceases to function. On de-selection it becomes automatically re-instated.

WIRE TRAP

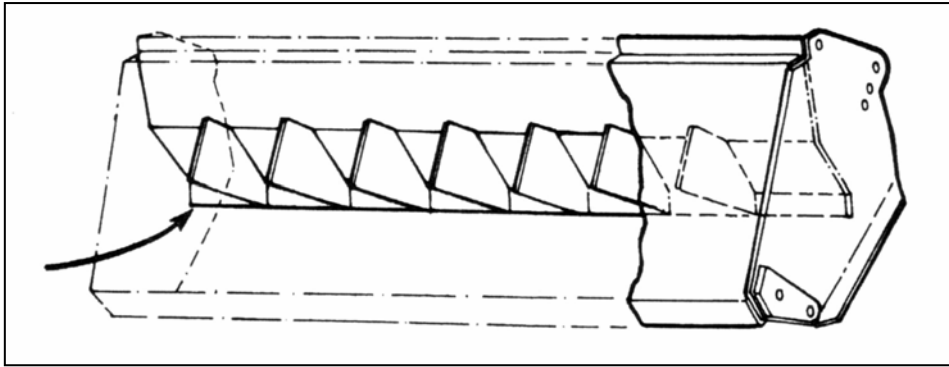

Both flail hoods are equipped with a 'wire cutting edge' welded into the underside – this plate should not be interfered with or modified in any way.

Any wire caught in the rotor must be removed immediately.

REMOVING WIRE

Select rotor '**OFF**' and wait until it has **stopped rotating**.

STOP the tractor and pocket the key – **only then remove the wire**.

Do not reverse the rotor in an attempt to unwind any wire.

WARNING

Ensure both tractor engine and machine are switched off and the rotor at a complete standstill before approaching the flail head.

OVERHEAD OBSTRUCTIONS

Always be aware the machine is approximately 4 metres high when folded and take extra care when maneuvering in areas with overhead obstacles especially power cables.

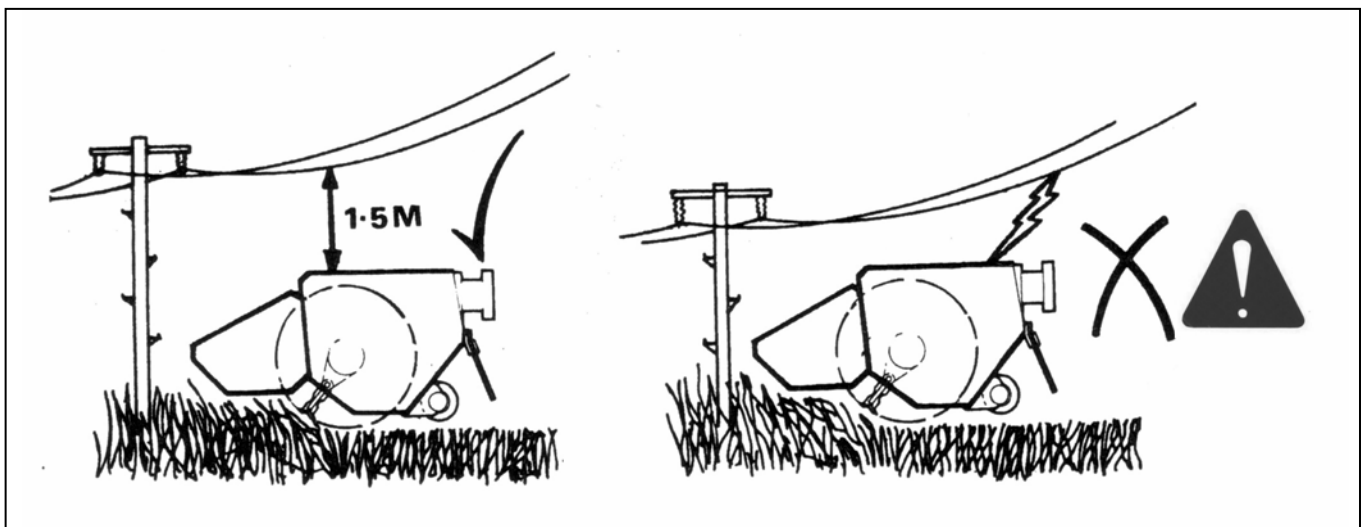

If in doubt consult your local electricity company regarding a safe procedure for work.

HEDGE CUTTING PROCEDURE

Preliminary Precautions

ALWAYS inspect the work area beforehand and remove any hazardous objects or materials. Note the location of any immovable obstructions in order that they will be avoided whilst working the machine.

UPWARD CUTTING

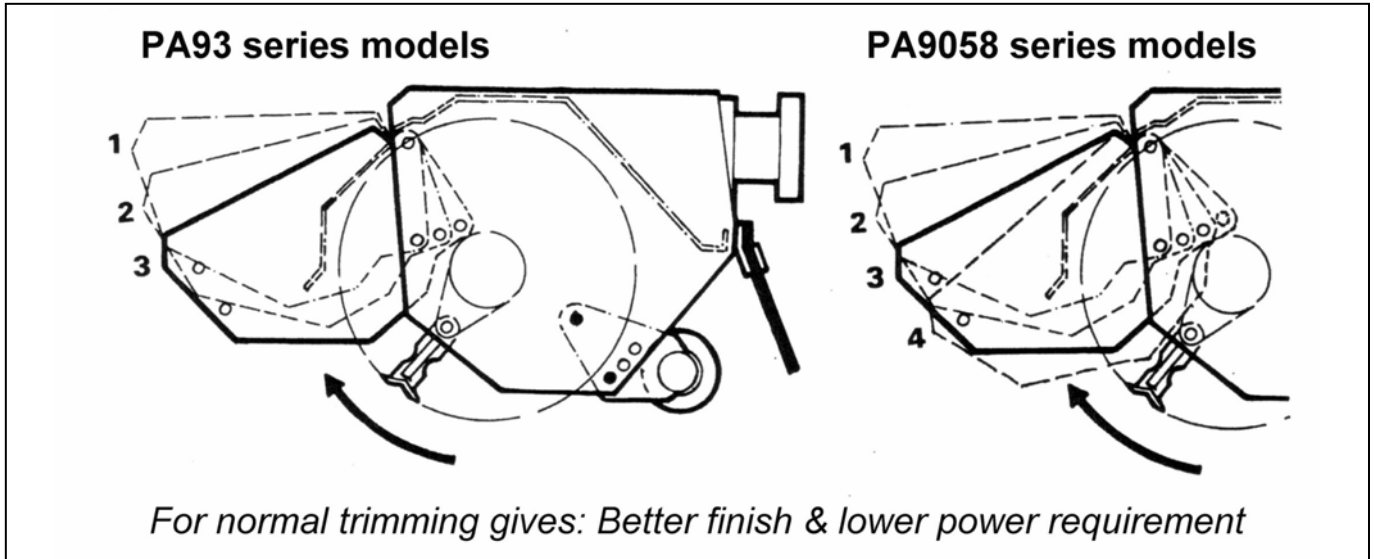

Front hood and rear flap **must always** be in position

DOWNWARD CUTTING

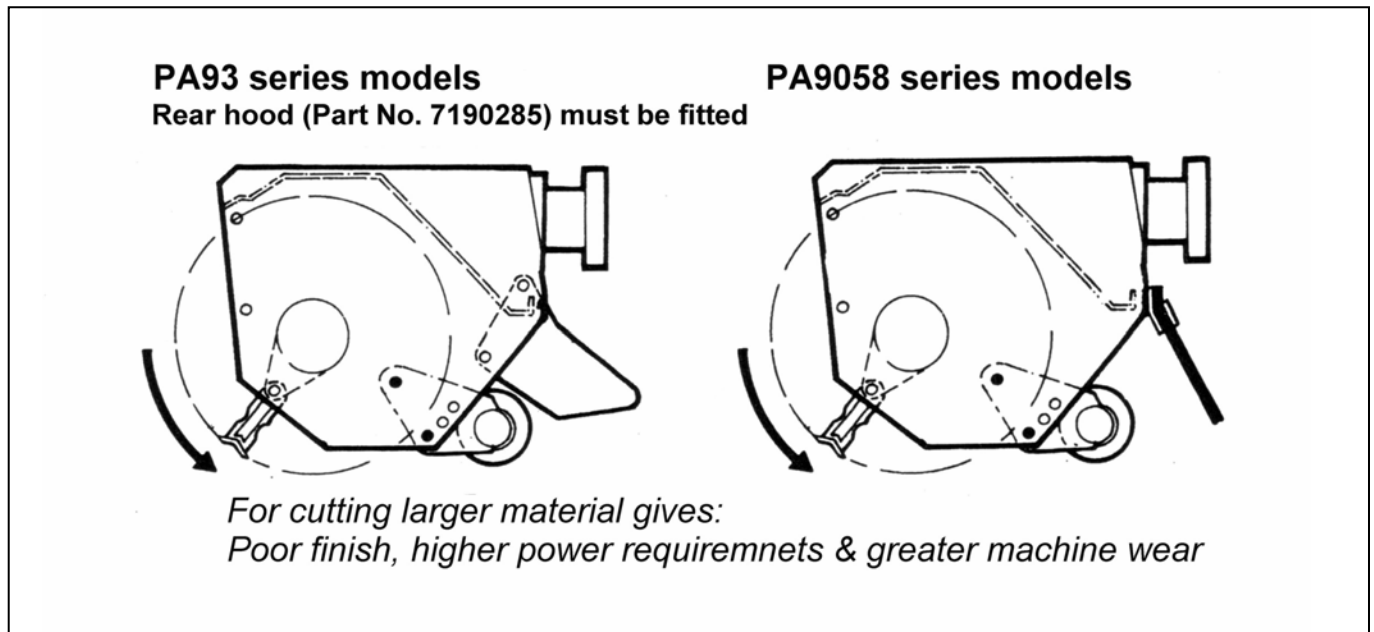

REVERSING ROTATION – Ti models only

Select rotor 'OFF'

Wait until rotor has **stopped** turning.

Swing lever stop gate through 180° to allow opposite rotation to be selected.

CAUTION: Do not remove the lever stop gate.

REVERSING ROTATION – PA93 Si models only

Fully extend the armhead and lower flail to the ground to minimise oil loss.

Release the hoses from the flail motor rigid pipes or the rotor control valve and interchange. **Do not** interchange the flail supply and return hoses at any other point as the hose routing and cross overs in the installation are necessary to allow the hoses to flex correctly during arm movements.

To ascertain the direction of cut without running the machine the following applies:

Connection **MP** - Lower motor rigid pipe} **upward cutting**

Connection **MR** - Upper motor right pipe}

Connection **MP** - Upper motor rigid pipe} **downward cutting**

Connection **MR** - Lower motor rigid pipe}

GRASS CUTTING – Flails must cut upwards

PA93 series models

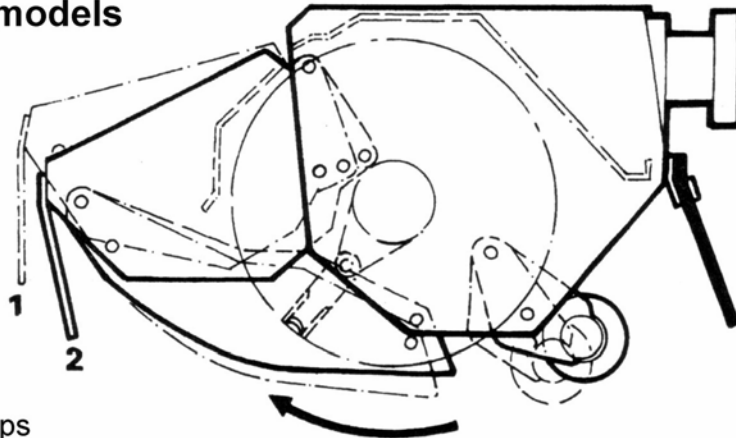

Front hood c/w flaps

Front hood c/w flaps, skids and rear flap must be fitted.

The mounting holes allow two positions on the front hood and two positions for the skids - any combination of these positions may be used.

The roller can be set in positions 2 and 3 for bushed rollers or positions 2, 3 and 4 for ball bearing rollers.

PA9058 series models

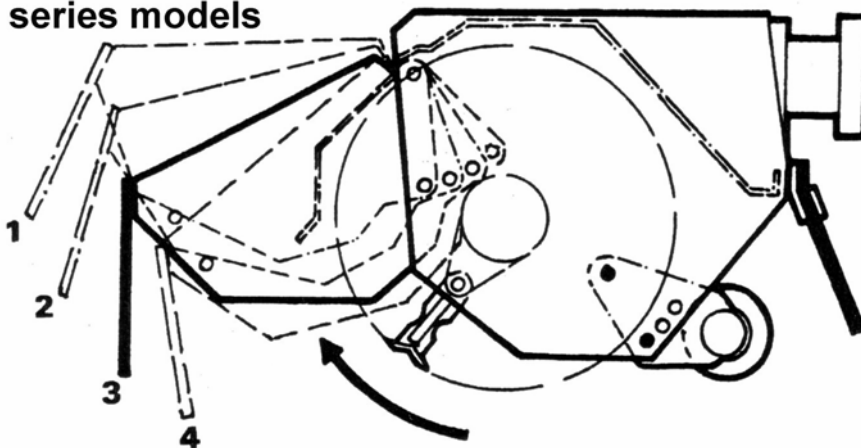

A front hood c/w flaps and a rear flap must be fitted. The front hood must be set in the lowest position which allows the material to be cut. The roller may be set in positions 2 or 3.

ROLLER POSITION – PA93 models only

Bushed Roller

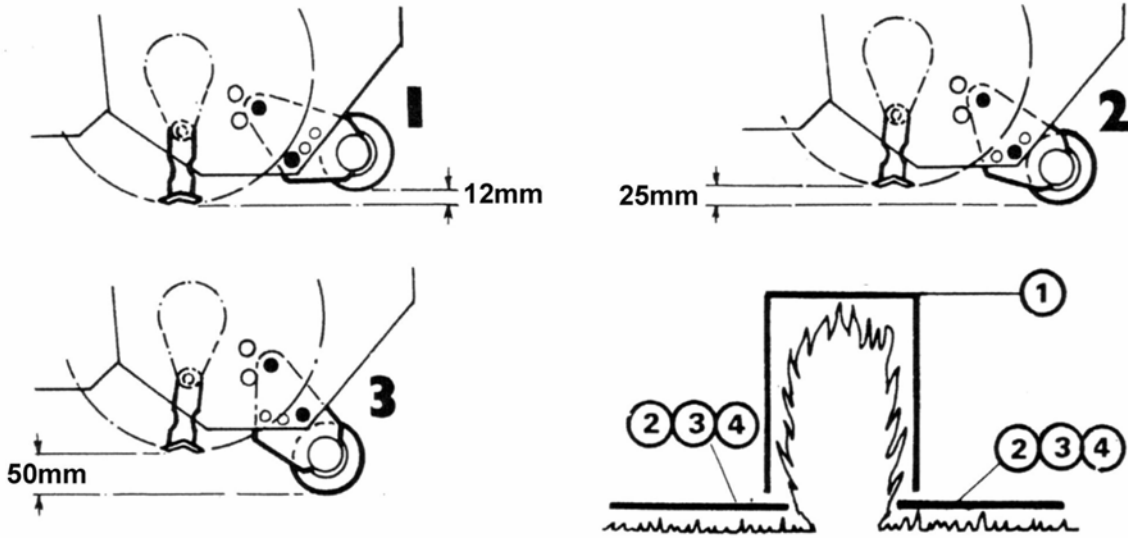

Ball Bearing Roller

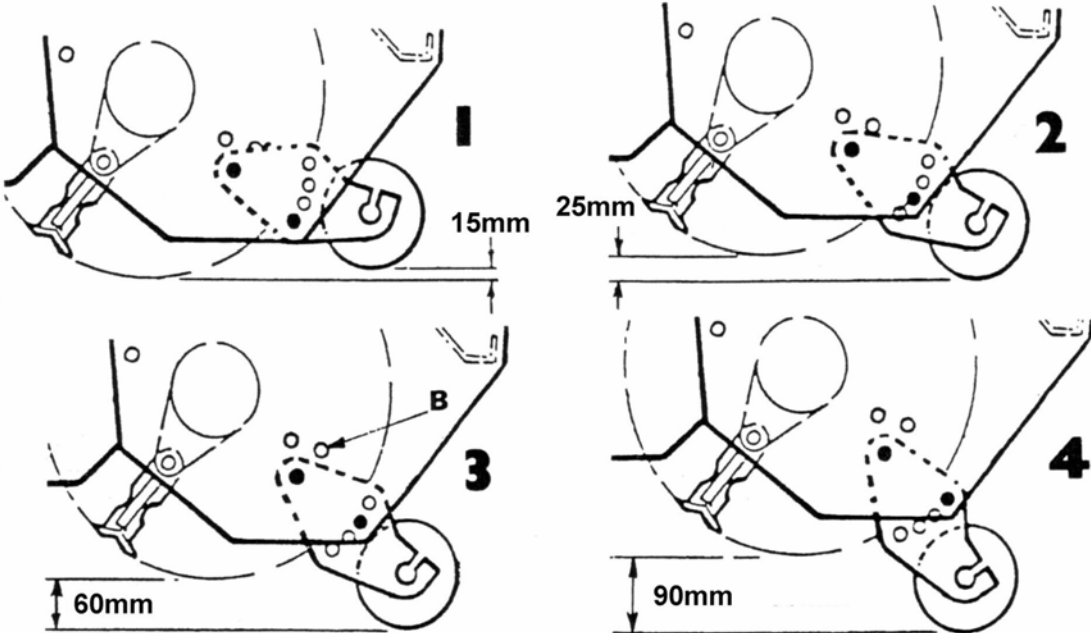

WARNING
The ball bearing roller must never be mounted in position 'B'.

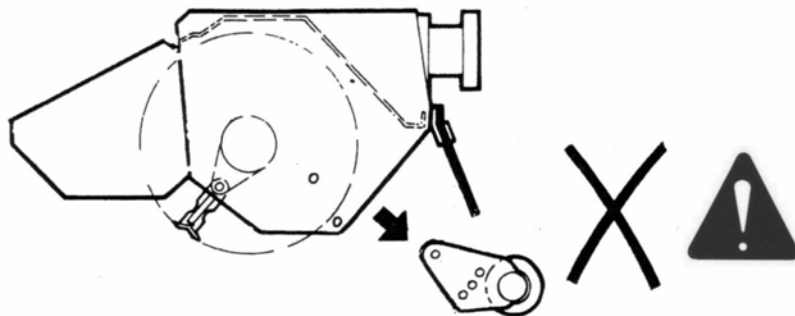

ROLLER POSITION – PA9058 models only

Bushed Roller

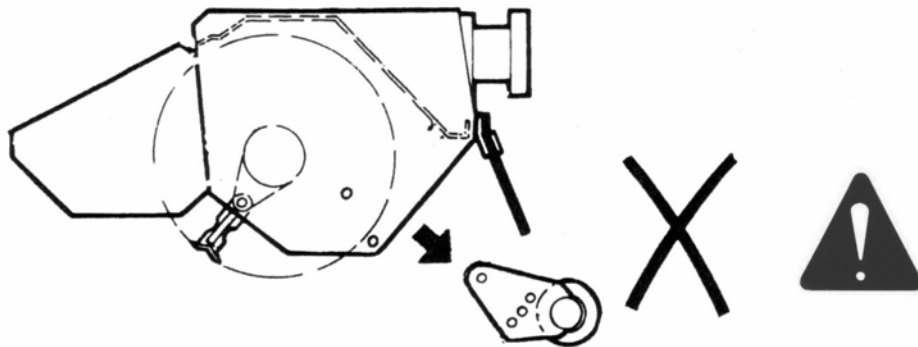
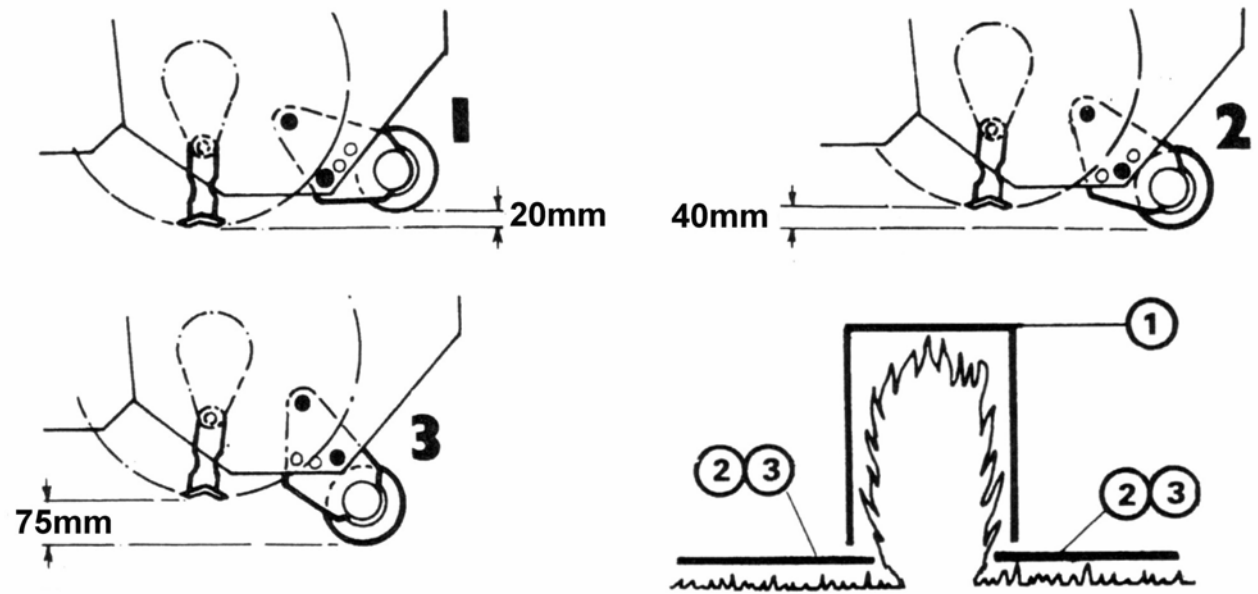

CUTTING SEQUENCE

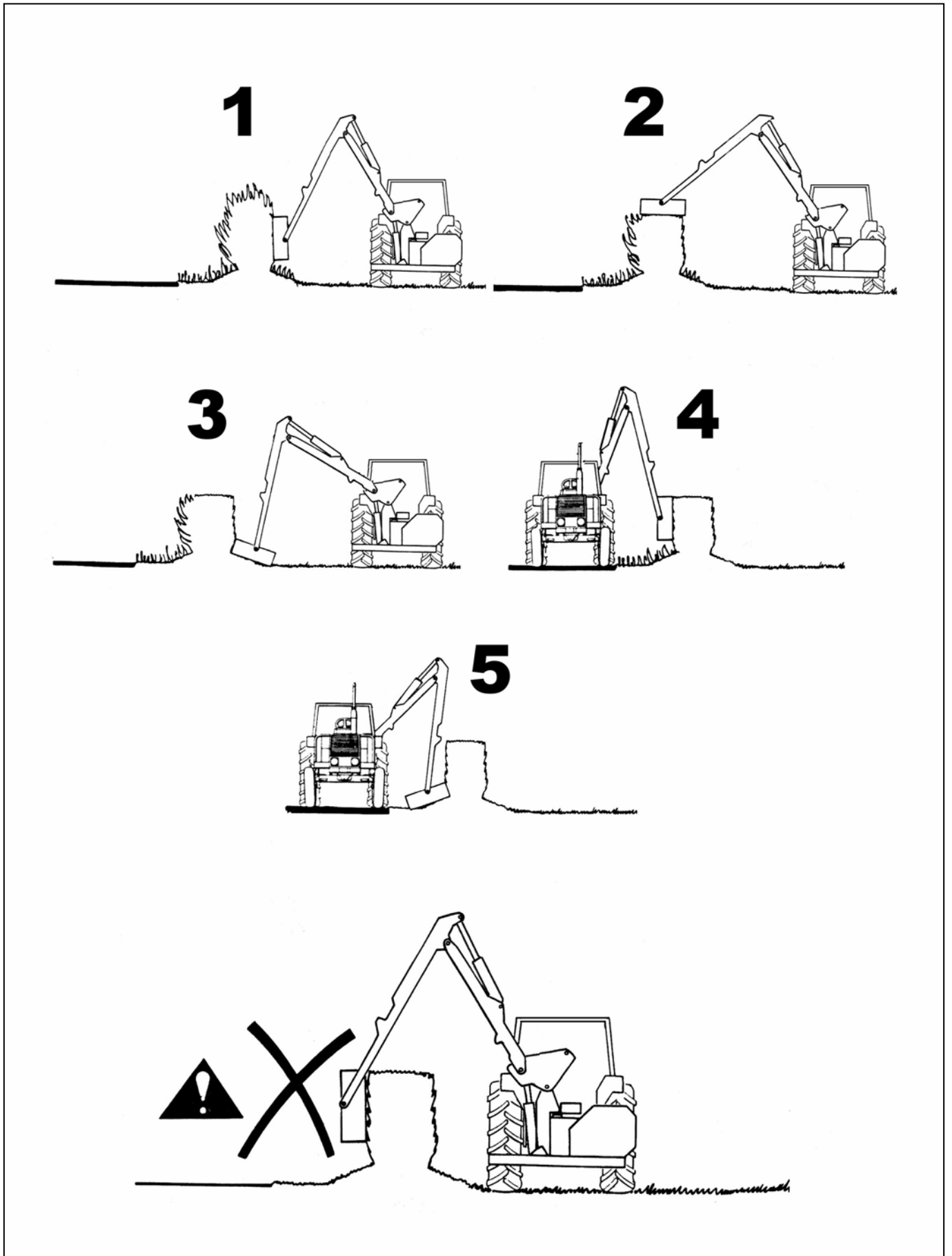

LIFT FLOAT KIT (Optional extra for ground cutting)

The hydraulic float kit, if fitted, should be mounted as shown, (*see diagram below*), clamped to the lift ram barrel. On electric controlled machines the cable from the poppet valve solenoid is connected to the auxiliary switch on the switchbox, It is permissible to also to have the angle float facility connected to the auxiliary switch - in this case both functions will operate in unison.

In work with the poppet valve open the flail head will automatically follow the ground contours.

The float action is engaged either:

By selection of the auxiliary (angle float) switch on electric machines

Or by manually lifting the knurled plunger on top of the poppet valve out of the 'V' groove and rotating through 90 degrees on cable operated machines.

The lift control should be operated to take a proportion of the flail head weight off the flail roller. This is important, too little weight on the roller will leave uncut areas of grass while with too much weight on the roller the ground will be scalped in places and increased flail wear, damage, or even loss of flails could occur.

To revert to standard operation the accumulator is isolated from the lift ram, by deselecting the float switch or by returning the knurled plunger to the 'off' position.

On electric machines where both float functions are fitted a 'switching kit' (*Part Number 8402303*) is available which isolates the angle float. This allows the machine to be operated with either the lift and angle floats functioning together or with the lift float operating alone.

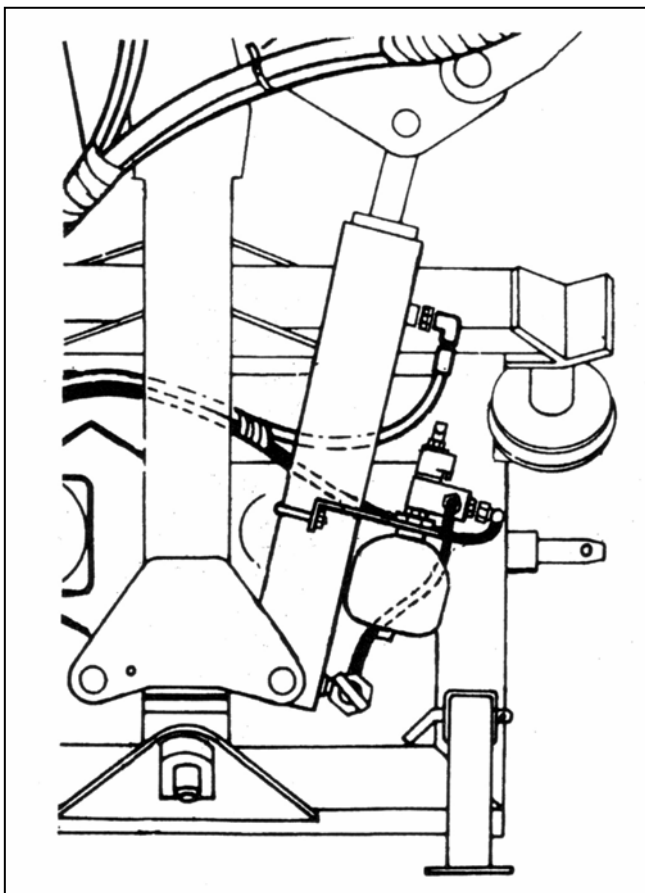

FLOATING HEAD ANGLE FACILITY

Optional Extra for PA93E, PA93E-AHC and PA9058E

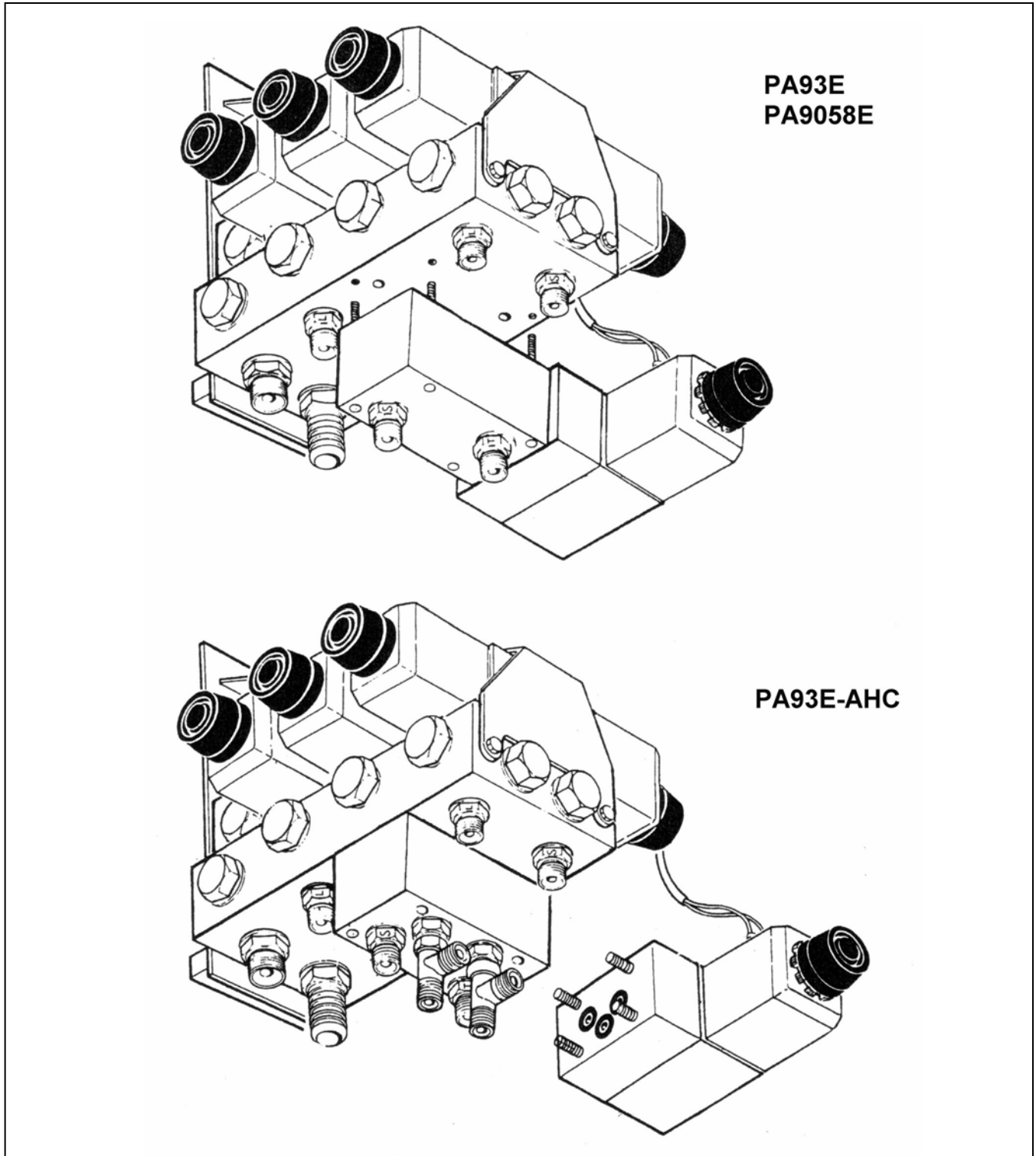

This facility will allow the flail head to angle itself automatically to suit the contours of the ground – it is activated by selecting 'B'.

The kit is bolted in position as shown in the diagram above. The 'O' Rings from either the hose plate on the PA93E and PA9058E models or the compensator valve blanking plate on the PA93E-AHC model must be extracted carefully and re-used.

The two-core cable is connected from the solenoid to the common link harness and connection 9 on the main harness.

MAINTENANCE

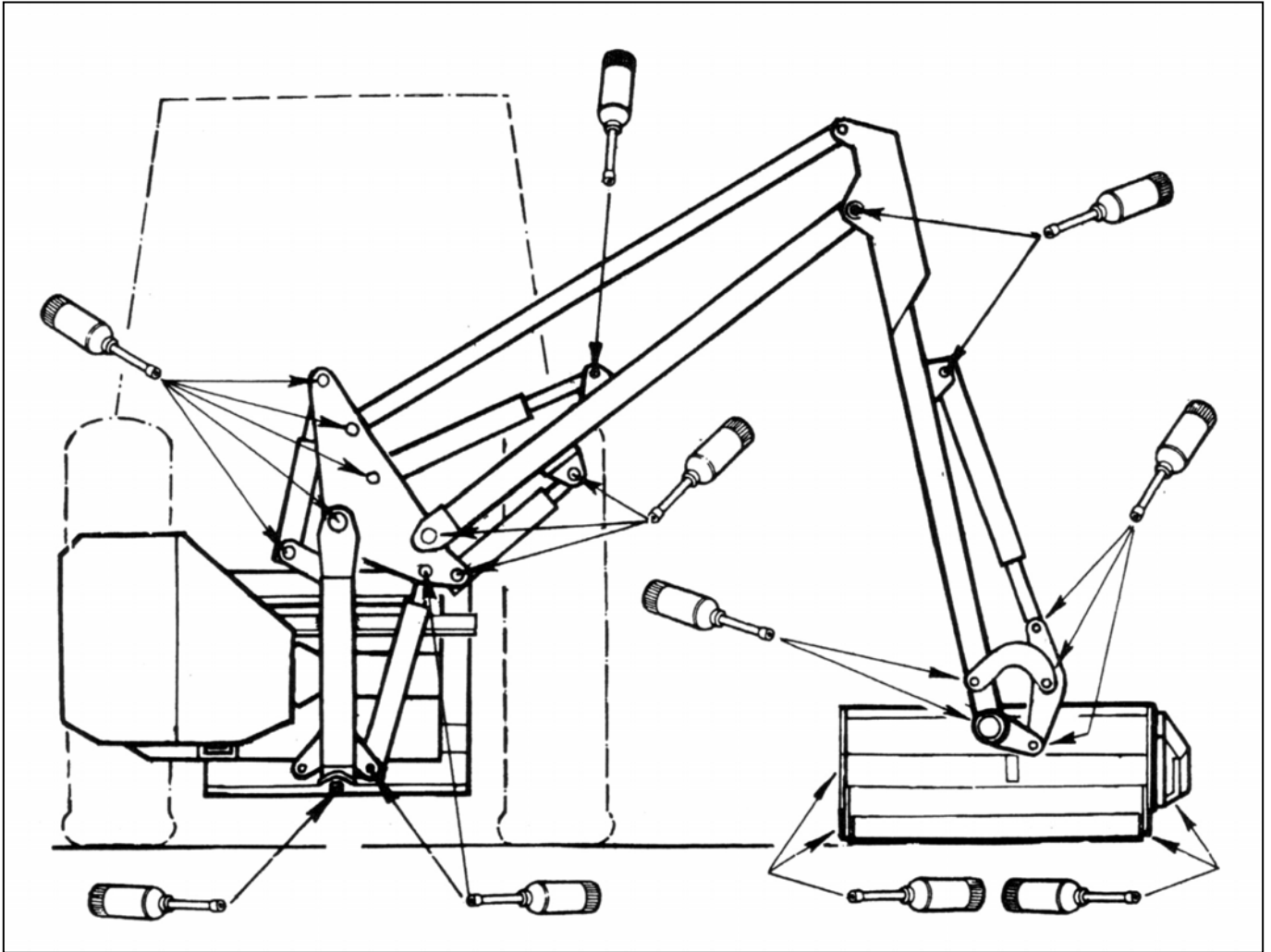

LUBRICATION

General

Grease daily all points shown.

Power Take-Off Shaft

The PTO Shaft and its guards should be regularly examined. The universal joints should be greased very sparingly i.e. one shot weekly.

Note: *Over greasing a universal joint will 'blow-out' the cork or neoprene sealing rings that exclude the dirt from the needle bearings inside.*

The two halves of the plastic guard should be checked daily to ensure that they can spin freely on the shaft. The nylon slip rings, which support the guard on the drive shaft, should be lightly greased at weekly intervals.

The telescopic drive shaft should be similarly separated and grease applied to the internal shaft at approximately 100 hour intervals.

HYDRAULIC SYSTEM

Oil supply

Check the oil level in the reservoir daily.

No fixed time period can be quoted for oil changes as operating conditions and maintenance standards vary so widely. Burnt and scorched oil odours and the oil darkening and thickening are all signs of oxidation and indicate the oil should be changed.

Moisture, which results from condensation, can become entrapped in the oil and cannot be removed by filtration so that water contamination is progressive.

Contamination can be reduced by:

- a) *Cleaning around the reservoir cap before removal, and keeping that area clean.*
- b) *Using clean containers when replenishing the system.*
- c) *Regular servicing of the filtration system.*

Filtration Maintenance

A 125-micron suction strainer and a low-pressure 10-micron full flow return line filter protect the machine.

Suction strainer

The strainer is permanently fixed within the reservoir.

Should symptoms of pump cavitation or spongy intermittent operation occur the tank must be drained and flushed out with a suitable cleaning agent e.g. clean diesel oil.

Return Line Filter

The elements should be changed after the first 50 hours and thereafter at 500-hour intervals. It is important to note hours worked as if the filter becomes blocked an internal by-pass within the canister will operate and no symptoms of filter malfunction will occur to jog your memory.

FLAIL HEAD

Frequently inspect the rotor assembly for damaged or missing flails. Bolts and nuts securing the flails to the rotor should be regularly checked and kept tight. The correct torque setting for these locknuts is 135 Nm (100 lbf/ft.). Use only the correct flail bolt and locking nut. Check the flail pivot bushes for possible damage or wear - *they do not require oil*.

Do not attempt to run the rotor with flails missing. Im-balance will cause severe vibration and can rapidly damage the rotor shaft bearings. As an emergency measure if a flail is broken off or lost, remove another on the opposite side of the rotor to retain balance. Always replace flails in opposite pairs and never match up a new flail with a re-sharpened one, which will of course be lighter.

Blunt flails absorb a lot of power and leave an untidy finish to the work. They should be sharpened on a grindstone or with a portable grinder periodically.

WARNING: Wear protective gear when sharpening flails.

Ensure that the bearing housings and hydraulic mounting nuts and bolts are kept tight. They should be checked during servicing.

CABLES

The cables operate on a push/pull system with the spool centering springs always returning the spool to the neutral position when the handle is released.

Care should be taken during installation and operation to ensure that the cables are not trapped or kinked. Any abrasion or damage to the outer casing should be sealed with plastic insulation tape to avoid moisture penetrating.

No routine adjustments of the cables are necessary, as they do not stretch. The threaded collar is correctly adjusted when the lever is in a vertical position in its housing allowing an equal amount of travel in either direction.

CAUTION:

On no account should any attempt be made to lubricate the cables, which are assembled with a special lubricant during manufacture.

NOTE:

Take care to ascertain the correct cable connections on both the control unit and the valve in the event of cable replacement.

HYDRAULIC HOSES

The condition of all hoses should be carefully checked during routine service of the machine. Hoses that have been chafed or damaged on their outer casing should be securely wrapped with waterproof adhesive tape to stop the metal braid from rusting. Hoses that have suffered damage to the metal braid should be changed at the earliest opportunity.

Hose replacement

- a) *Replace one hose at a time to avoid the risk of wrong connections.*
- b) *When the hose is screwed to an additional fitting or union, use a second spanner on the union to avoid breaking both seals.*
- c) *Do not use jointing compound on the threads.*
- d) *Avoid twisting the hose. Adjust the hose line to ensure freedom from rubbing or trapping before tightening hose end connections.*

Before changing hoses study the installation these are carefully calculated to prevent hose damage during operation. Always replace hoses in exactly the same manner. This is especially important for the flail hoses where they must be crossed, upper to lower, at the dipper and head pivots. The 90-degree elbows at the head bracket must point directly across the pivot and the hoses must have no slack at this point.

Two hose clips are provided at either end of the large bore suction and return hoses. These should be positioned so that their worm drive barrels are opposed at 180 degrees to reduce the possibility of air entering the system. A stop tap is provided to enable the suction hose to be changed without draining the tank.

Hose warranty

Warranty is limited to replacement of hoses that have failed due to faulty materials or manufacture. Warranty will not be considered on hoses that have suffered damage by abrasion, cuts or being pinched or trapped while in work. Neither will a claim be considered where a hose end has been damaged by a blow or where overtightening has damaged the threads or unions.

PTO GEARBOX

The gearbox is rigidly bolted on to the main frame and has a filler plug. Oil level is correct when level with the filler plug aperture. The gearbox oil should be changed every year or at 600-hour intervals: *whichever occurs first*. The capacity of the gearbox is .25 Litres (1/2 pint) S.A.E 30/50 Universal Tractor Oil.

HOSE CONNECTIONS – PA93

MAIN CONTROL VALVE

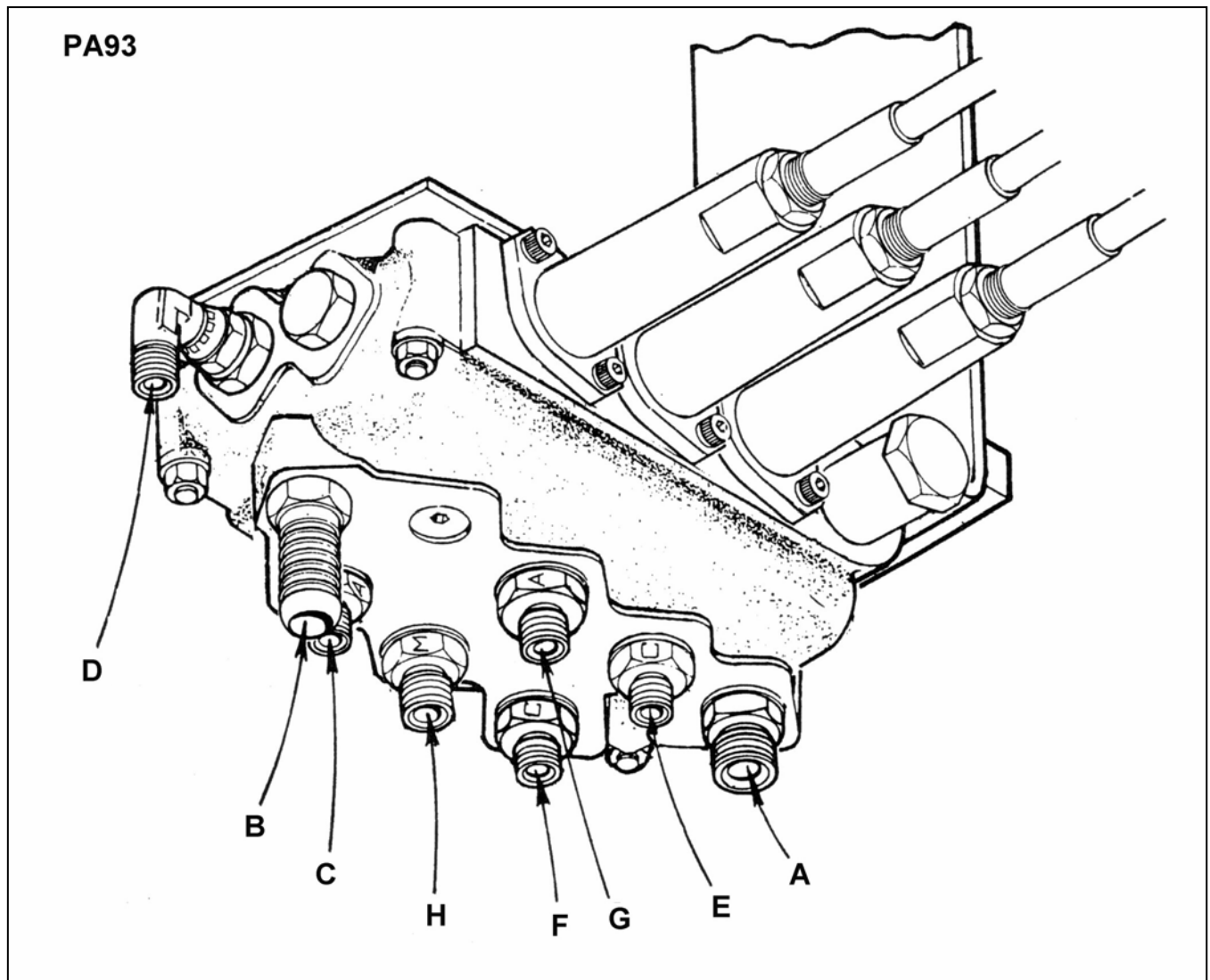

A - Supply

B - Return (*Ti illustrated*)

C – Lift Base (Restrictor A)

D – Lift Gland

E – Reach Base (Restrictor C)

F– Reach Gland (Restrictor C)

G – Angle Base (Restrictor A)

H – Angle Gland (Restrictor M)

HOSE CONNECTIONS – PA9058

MAIN CONTROL VALVE

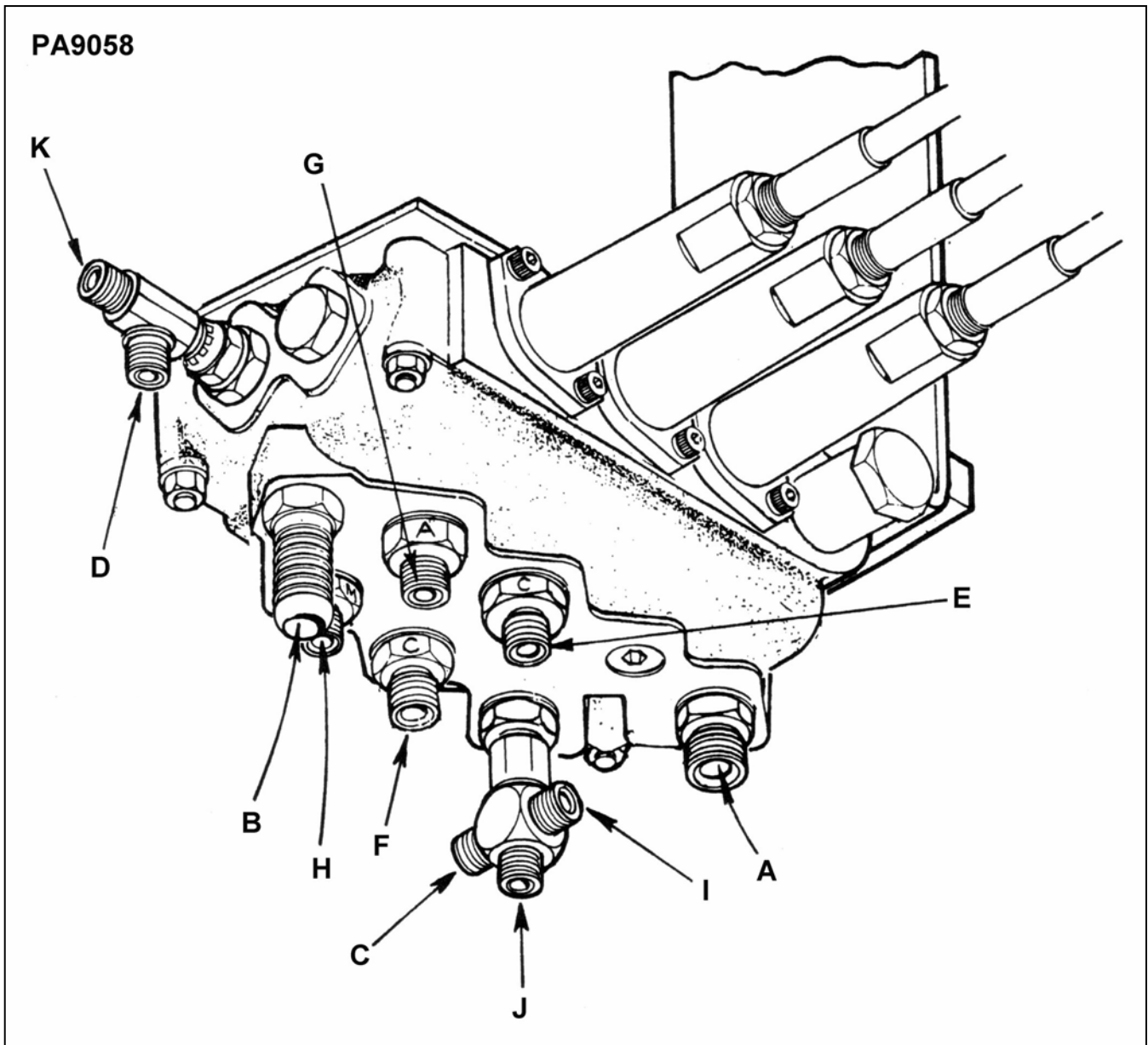

- A - Supply
- B - Return (*Not illustrated*)
- C - Lift Base
- D - Lift Gland
- E - Reach Base (Restrictor C)
- F - Reach Gland (Restrictor C)
- G - Angle Base (Restrictor A)
- H - Angle Gland (Restrictor M)
- I - Breakaway Ram
- J - To Connection 'K'
- K - To Connection 'J'

HOSE CONNECTIONS – PA93E & PA9058E

MAIN CONTROL VALVE

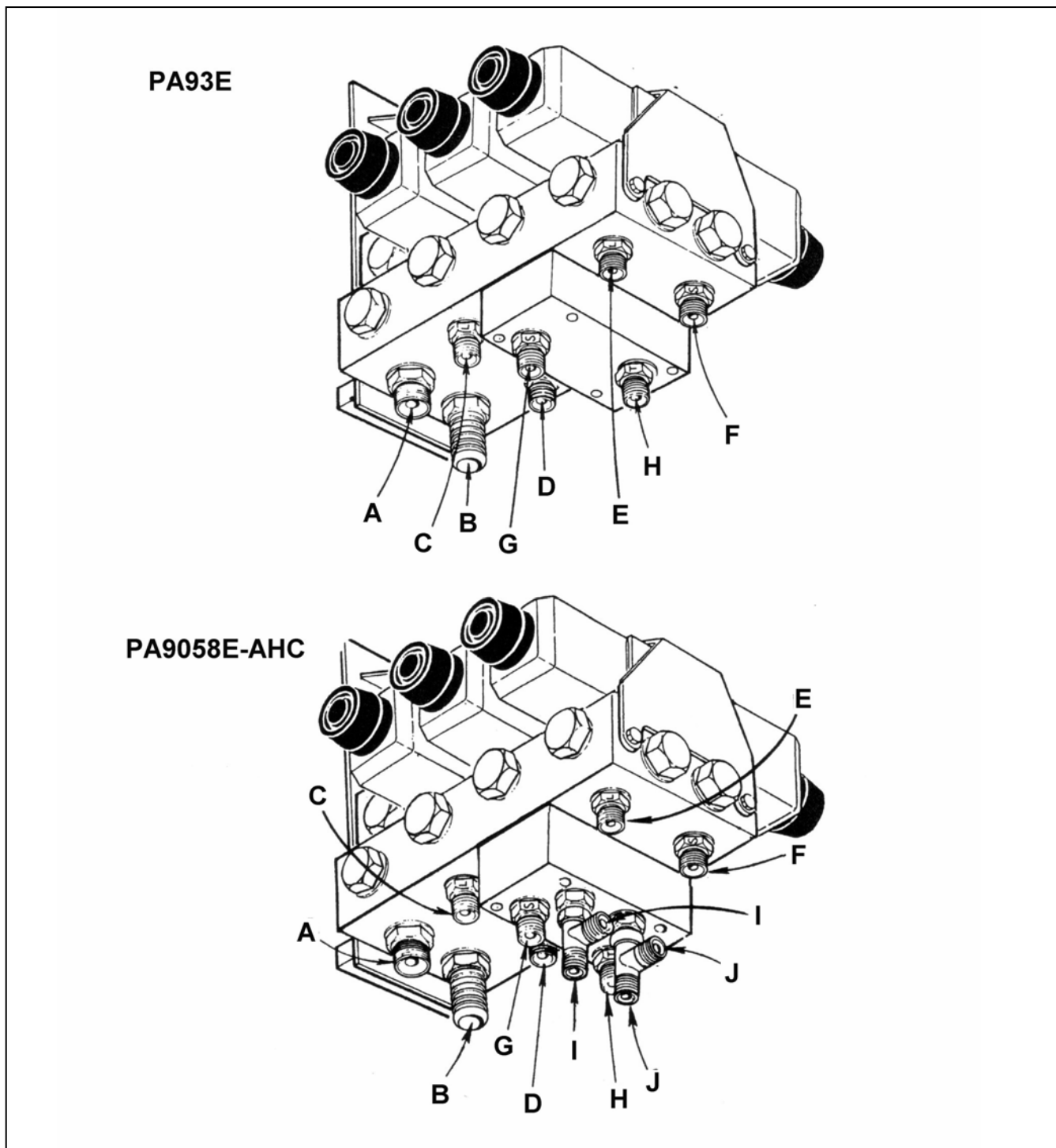

A – Supply

B – Return

C – Lift Base (Restrictor L)

D – Lift Gland

E – Reach Base (Restrictor L)

F – Reach Gland (Restrictor S)

G – Angle Base (Restrictor S)

H – Angle Gland (Restrictor T)

I – Compensator Base

J – Compensator Gland

PA9058E

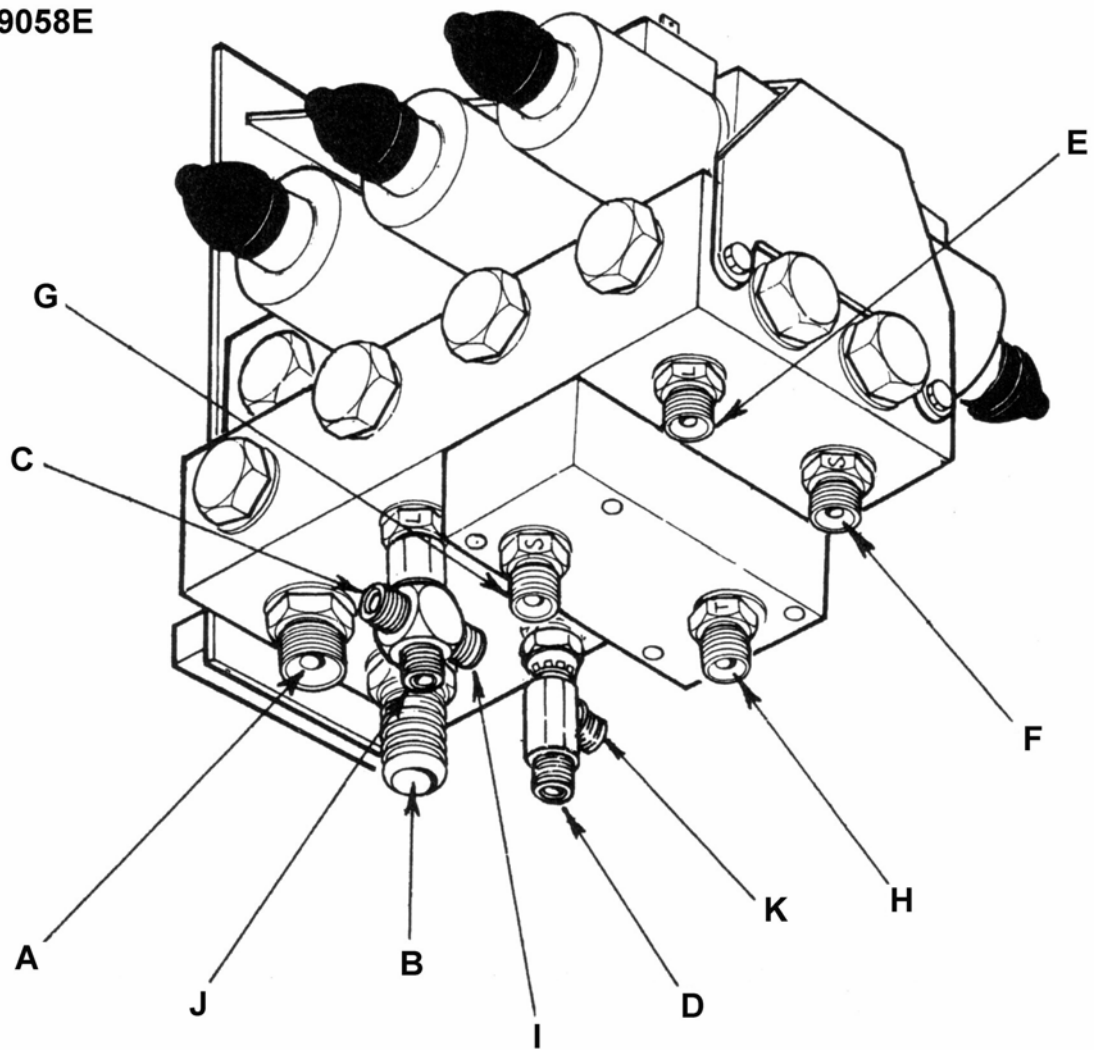

A - Supply

B - Return

C - Lift Base

D - Lift Gland

E - Reach Base

F - Reach Gland

G - Angle Base

H - Angle Gland

I - Breakaway Ram

J - To Connection 'K'

K - To Connection 'J'

ROTOR CONTROL & ROTOR RELIEF VALVES

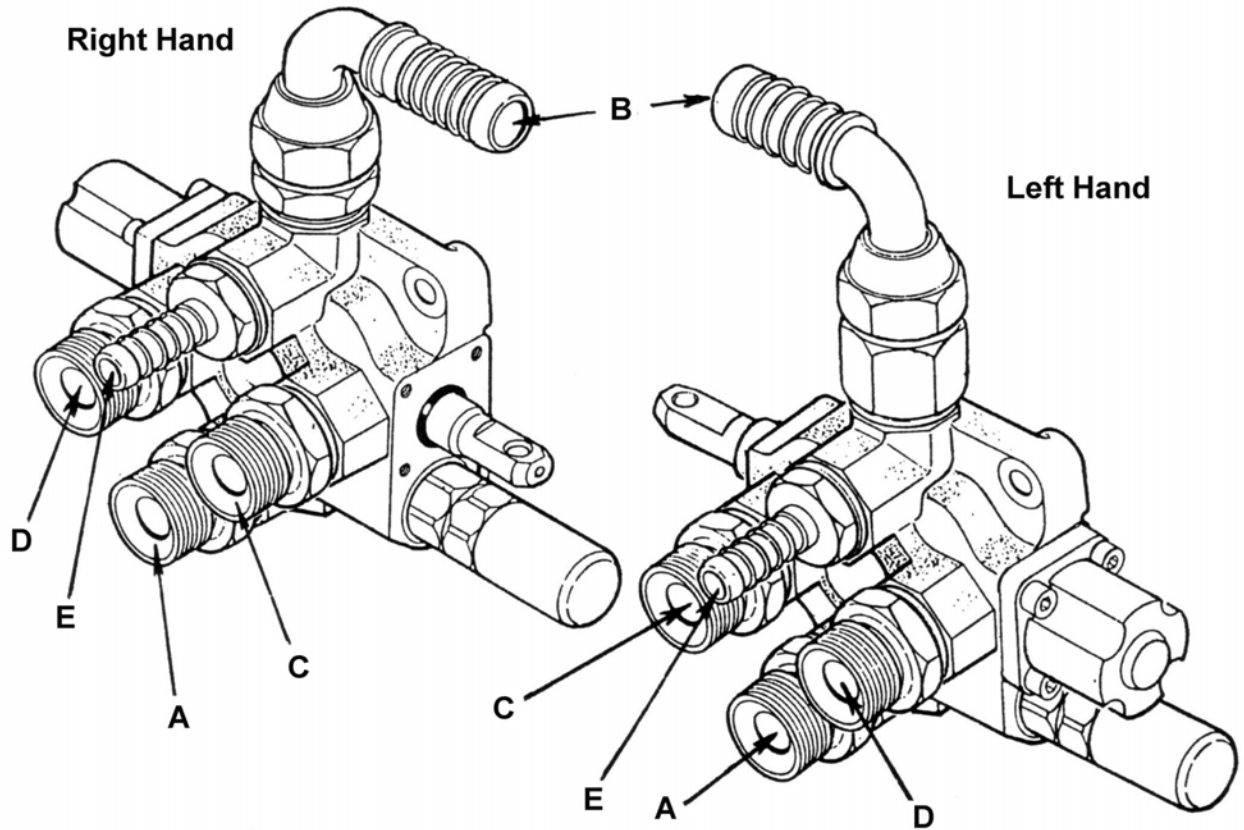

ROTOR CONTROL VALVE - All Totally Independent Machines

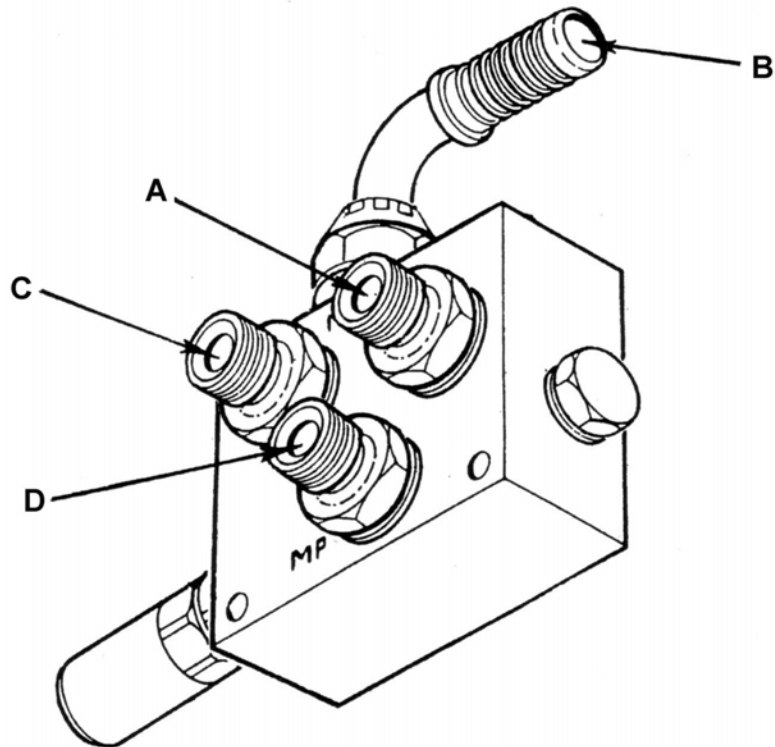

ROTOR RELIEF VALVE - All Semi Independant Machines

- A – Supply from Pump
- B – Return to Tank
- C – Motor Upper

- D – Motor Lower
- E – Return from Main Valve

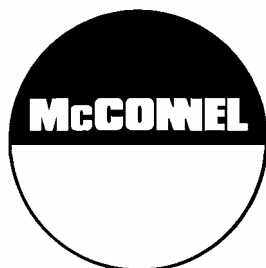

McConnel Limited, Temeside Works, Ludlow, Shropshire SY8 1JL. England.
Telephone: 01584 873131. Facsimile: 01584 876463. www.mcconnel.com