

Publication 472
February 2005
Part No. 41570.72
Revised: 15.09.10



PA ECO Series

50, 55 & 60 ECO

HEDGE & GRASS CUTTERS

Operator Manual



IMPORTANT

VERIFICATION OF WARRANTY REGISTRATION



DEALER WARRANTY INFORMATION & REGISTRATION VERIFICATION

It is imperative that the selling dealer registers this machine with McConnel Limited before delivery to the end user – failure to do so may affect the validity of the machine warranty.

To register machines go to the McConnel Limited web site at www.mcconnel.com, log onto 'Dealer Inside' and select the 'Machine Registration button' which can be found in the Service Section of the site. Confirm to the customer that the machine has been registered in the section below.

Should you experience any problems registering a machine in this manner please contact the McConnel Service Department on 01584 875848.

Registration Verification

Dealer Name:
Dealer Address:
Customer Name:
Date of Warranty Registration:/...../..... Dealer Signature:

NOTE TO CUSTOMER / OWNER

Please ensure that the above section above has been completed and signed by the selling dealer to verify that your machine has been registered with McConnel Limited.

IMPORTANT: During the initial 'bedding in' period of a new machine it is the customer's responsibility to regularly inspect all nuts, bolts and hose connections for tightness and re-tighten if required. New hydraulic connections occasionally weep small amounts of oil as the seals and joints settle in – where this occurs it can be cured by re-tightening the connection – *refer to torque settings chart below*. The tasks stated above should be performed on an hourly basis during the first day of work and at least daily thereafter as part of the machines general maintenance procedure.

TORQUE SETTINGS FOR HYDRAULIC FITTINGS

HYDRAULIC HOSE ENDS		
BSP	Setting	Metric
1/4"	18 Nm	19 mm
3/8"	31 Nm	22 mm
1/2"	49 Nm	27 mm
5/8"	60 Nm	30 mm
3/4"	80 Nm	32 mm
1"	125 Nm	41 mm
1.1/4"	190 Nm	50 mm
1.1/2"	250 Nm	55 mm
2"	420 Nm	70 mm

PORT ADAPTORS WITH BONDED SEALS		
BSP	Setting	Metric
1/4"	34 Nm	19 mm
3/8"	47 Nm	22 mm
1/2"	102 Nm	27 mm
5/8"	122 Nm	30 mm
3/4"	149 Nm	32 mm
1"	203 Nm	41 mm
1.1/4"	305 Nm	50 mm
1.1/2"	305 Nm	55 mm
2"	400 Nm	70 mm

WARRANTY POLICY

WARRANTY REGISTRATION

All machines must be registered, by the selling dealer with McConnell Ltd, before delivery to the end user. On receipt of the goods it is the buyer's responsibility to check that the Verification of Warranty Registration in the Operator's Manual has been completed by the selling dealer.

1. LIMITED WARRANTIES

- 1.01. All machines supplied by McConnell Limited are warranted to be free from defects in material and workmanship from the date of sale to the original purchaser for a period of 12 months, unless a different period is specified.
- 1.02. All spare parts supplied by McConnell Limited are warranted to be free from defects in material and workmanship from the date of sale to the original purchaser for a period of 6 months.
- 1.03. The manufacturer will replace or repair for the purchaser any part or parts found, upon examination at its factory, to be defective under normal use and service due to defects in material or workmanship. Returned parts must be complete and unexamined.
- 1.04. This warranty does not apply to any part of the goods, which has been subjected to improper or abnormal use, negligence, alteration, modification, fitment of non-genuine parts, accident damage, or damage resulting from contact with overhead power lines, damage caused by foreign objects (e.g. stones, iron, material other than vegetation), failure due to lack of maintenance, use of incorrect oil or lubricants, contamination of the oil, or which has served its normal life. This warranty does not apply to any expendable items such as blades, flails, flap kits, skids, soil engaging parts, shields, guards, wear pads or pneumatic tyres.
- 1.05. Temporary repairs and consequential loss - i.e. oil, downtime and associated parts are specifically excluded from the warranty.
- 1.06. Warranty on hoses is limited to 12 months and does not include hoses which have suffered external damage. Only complete hoses may be returned under warranty, any which have been cut or repaired will be rejected.
- 1.07. Machines must be repaired immediately a problem arises. Continued use of the machine after a problem has occurred can result in further component failures, for which McConnell Ltd cannot be held liable, and may have safety implications.
- 1.08. Except as provided herein, no employee, agent, dealer or other person is authorised to give any warranties of any nature on behalf of McConnell Ltd.
- 1.09. For machine warranty periods in excess of 12 months the following additional exclusions shall apply:
 - 1) Hoses, external seals, exposed pipes and hydraulic tank breathers.
 - 2) Filters.
 - 3) Rubber mountings.
 - 4) External electric wiring.

N.B. Warranty cover will be invalid if any non-genuine parts have been fitted or used. Use of non-genuine parts may seriously affect the machine's performance and safety. McConnell Ltd. cannot be held responsible for any failures or safety implications that arise due to the use of non-genuine parts.

2. REMEDIES AND PROCEDURES

- 2.01. The warranty is not effective unless the Selling Dealer registers the machine, via the McConnel web site and confirms the registration to the purchaser by completing the Verification of Warranty Registration in the operator's manual.
- 2.02. Any fault must be reported to an authorised McConnel dealer as soon as it occurs. Continued use of a machine, after a fault has occurred, can result in further component failure for which McConnel Ltd cannot be held liable.
- 2.03. Repairs should be undertaken within two days of the failure. Claims submitted for repairs undertaken more than 2 weeks after a failure has occurred, or 2 days after the parts were supplied will be rejected, unless the delay has been authorised by McConnel Ltd.
- 2.04. All claims must be submitted, by an authorised McConnel Service Dealer, within 30 days of the date of repair.
- 2.05. Following examination of the claim and parts the manufacture will pay, at their discretion, for any valid claim the cost of any parts and an appropriate labour allowance if applicable.
- 2.06. The submission of a claim is not a guarantee of payment.
- 2.07. Any decision reached by McConnel Ltd. is final.

3. LIMITATION OF LIABILITY

- 3.01. The manufacturer disclaims any express (except as set forth herein) and implied warranties with respect to the goods including, but not limited to, merchantability and fitness for a particular purpose.
- 3.02. The manufacturer makes no warranty as to the design, capability, capacity or suitability for use of the goods.
- 3.03. Except as provided herein, the manufacturer shall have no liability or responsibility to the purchaser or any other person or entity with respect to any liability, loss, or damage caused or alleged to be caused directly or indirectly by the goods including, but not limited to, any indirect, special, consequential, or incidental damages resulting from the use or operation of the goods or any breach of this warranty. Notwithstanding the above limitations and warranties, the manufacturer's liability hereunder for damages incurred by the purchaser or others shall not exceed the price of the goods.
- 3.04. No action arising out of any claimed breach of this warranty or transactions under this warranty may be brought more than one (1) year after the cause of the action has occurred.

4. MISCELLANEOUS

- 4.01. The manufacturer may waive compliance with any of the terms of this limited warranty, but no waiver of any terms shall be deemed to be a waiver of any other term.
- 4.02. If any provision of this limited warranty shall violate any applicable law and is held to be unenforceable, then the invalidity of such provision shall not invalidate any other provisions herein.
- 4.03. Applicable law may provide rights and benefits to the purchaser in addition to those provided herein.



For Safety and Performance ...

ALWAYS READ THIS BOOK FIRST

McCONEl LIMITED

**Temeside Works
Ludlow
Shropshire
England**

**Telephone: 01584 873131
www.mccommel.com**

NOISE STATEMENT

The equivalent daily personal noise exposure from this machine measured at the operators' ear is within the range 78 – 85 dB, these figures apply to a normal distribution of use where the noise fluctuates between zero and maximum. The figures assume that the machine is fitted to a tractor with a 'quiet' cab with the windows closed in a generally open environment. We recommend that the windows are kept closed. With the cab rear window open the equivalent daily personal noise exposure will increase to a figure within the range 82 – 88 dB. At equivalent daily noise exposure levels of between 85 – 90 dB ear protection is recommended – it should be used if any window is left open.

EC DECLARATION OF CONFORMITY

*Conforming to EEC Machinery Directive 98/37/EC**

We,

McCONNEL LIMITED,
Temeside Works, Ludlow, Shropshire SY8 1JL.

Declare under our sole responsibility that:

The product (type) *Tractor Mounted Hedgecutter*

.....

Product Code *PE50, PE55, PE60*

Serial No. & Date Type

Manufactured by the above company/*

.....

(insert business name and full address if not stated above)*

Complies with the required provisions of the Machinery Directive 98/37/EC, * previously Directive 89/392/EEC as amended by Directives 91/368/EEC, 93/44/EEC and 93/68/EEC.

The machinery directive is supported by;

- BS EN ISO 12100:2003 Safety of Machinery. This standard is made up of two parts; Part 1 Terminology, methodology, Part 2 Technical Specifications.
- BS EN 1050 Safety of machinery - Principles of risk assessment.
- and other national standards associated with its design and construction as listed in the Technical File.

The Machinery Directive is fully implemented into UK law by means of the Supply of Machinery (Safety) Regulations 1992 (SI 1992/3073) as amended by The Supply of Machinery (Safety) (Amendment) Regulations 1994 (SI 1994/2063).

Signed *John Frank*

on behalf of McCONNEL LIMITED

Responsible Person

Status: *Chief Design Engineer*

Date: *February 2005*

EC DECLARATION OF CONFORMITY

*Conforming to EEC Machinery Directive 98/37/EC**

We,

McCONNEL LIMITED,
Temeside Works, Ludlow, Shropshire SY8 1JL.

Declare under our sole responsibility that:

The product (type) *Arm Mounted Flailhead*

Product Code *BD12, BD16, F110, F112, F115, F012, F016*

Serial No. & Date Type

Manufactured by the above company/*

.....
(insert business name and full address if not stated above)*

Complies with the required provisions of the Machinery Directive 98/37/EC, * previously Directive 89/392/EEC as amended by Directives 91/368/EEC, 93/44/EEC and 93/68/EEC.

The machinery directive is supported by;

- BS EN ISO 12100:2003 Safety of Machinery. This standard is made up of two parts; Part 1 Terminology, methodology, Part 2 Technical Specifications.
- BS EN 1050 Safety of machinery - Principles of risk assessment.
- and other national standards associated with its design and construction as listed in the Technical File.

The Machinery Directive is fully implemented into UK law by means of the Supply of Machinery (Safety) Regulations 1992 (SI 1992/3073) as amended by The Supply of Machinery (Safety) (Amendment) Regulations 1994 (SI 1994/2063).

Signed *John Frank*

on behalf of McCONNEL LIMITED
Responsible Person

Status: *Chief Design Engineer*

Date: *February 2005*

LIST OF CONTENTS

	<i>Page No.</i>
General Information	1
Specifications	2
Safety Information	4
Preparation	
Vehicle / Tractor Preparation	8
Pre-Attachment – <i>Machine Preparation</i>	9
Oil Recommendations Chart	10
Initial Attachment of the Machine	11
Flailhead Attachment	16
Fitting Control Unit	17
Running Up Procedure	17
Detaching the Machine from the Tractor – <i>Removal Procedure</i>	18
Storage of the Machine	19
Subsequent Attachment to Identical Tractor	19
Subsequent Attachment to Different Tractor	19
Operation	
Preparation	20
Machine Controls – <i>Cable Controls Lever Identification & Function</i>	21
Machine Controls – <i>Control and Arm Movements</i>	22
Cable Rotor Control	23
XTC Proportional Controls	24
Breakaway System and Slew	28
Transportation	
Moving into the Transport Position	29
Transport Positions – <i>with and without Flailhead attached</i>	30
Transport Height	31
Overhead Obstructions	31
Moving from Transport to Work Position	31
Rotor Operation	
Engaging drive	32
Rotor Operating Speed	32
Tractor Forward Speed	32
Hedge Cutting Procedure	33
Safe Working Practices	
Working on Public Highways	34
General Working Practices	34
Working on Adverse Slopes	34
High Voltage Cables	35
Lift Float – <i>Optional Extra</i>	
Lift Float Kit – <i>Fitting Location</i>	36
Lift Float Kit – <i>Power Supply</i>	36

LIST OF CONTENTS - *Continued*

	<i>Page No.</i>
Maintenance	
Lubrication Points	37
PTO Shaft Inspection	37
PTO Shaft Lubrication	37
Hydraulic System	
Oil Supply	38
Filtration Maintenance	38
Suction Strainer	38
Return Line Filter	38
PTO Gearbox	38
Hydraulic Hoses	
Hose Replacement	39
Torque Settings	39
Control Cables	
Control Cable Information	40

GENERAL INFORMATION

Always read this manual before fitting or operating the machine – whenever any doubt exists contact your dealer or the McConnel Service Department for advice and assistance.

Use only McConnel Genuine Service Parts on McConnel Equipment and Machines

DEFINITIONS – *The following definitions apply throughout this manual:*

WARNING

An operating procedure, technique etc., which –
can result in personal injury or loss of life if not observed carefully.

CAUTION

An operating procedure, technique etc., which –
can result in damage to either machine or equipment if not observed carefully.

NOTE

An operating procedure, technique etc., which –
is considered essential to emphasis.

LEFT AND RIGHT HAND

This term is applicable to the machine when attached to the tractor and is viewed from the rear – this also applies to tractor references.

MACHINE & DEALER INFORMATION

Record the Serial Number of your machine on this page and always quote this number when ordering parts. Whenever information concerning the machine is requested remember also to state the make and model of tractor to which the machine is fitted.

Machine Serial Number:	Installation Date:
Machine Model details:	
Dealer Name:	
Dealer Address:	
Dealer Telephone No:	
Dealer Email Address:	

SPECIFICATIONS

All Models

- *Linkage Mounted*
- *Right Hand Build*
- *Totally Independent Hydraulics*
- *95°Power Slew*
- *Cable Controls*
- *Independent Rotor ON/OFF Valve*
- *200-litre Hydraulic Reservoir*
- *Choice of Operator Controls*

Optional Extras

- *Lift Float Kit*



This machine has the potential to be extremely dangerous, in the wrong hands it can kill or maim. It is therefore imperative that both owner, and operator of this machine, read and understand the following section to ensure that they are fully aware of the dangers that do, or may exist, and their responsibilities surrounding the use and operation of the machine. The operator of this machine is responsible not only for their own safety but equally for the safety of others who may come into the close proximity of the machine, as the owner you are responsible for both.

When the machine is not in use the cutting head should be lowered to rest on the ground. In the event of a fault being detected with the machine's operation it should be stopped immediately and not used again until the fault has been corrected by a qualified technician.

POTENTIAL SIGNIFICANT DANGERS ASSOCIATED WITH THE USE OF THIS MACHINE:

- ▲ *Being hit by debris thrown by rotating components.*
- ▲ *Being hit by machine parts ejected through damage during use.*
- ▲ *Being caught on a rotating power take-off (PTO) shaft.*
- ▲ *Being caught in other moving parts i.e.: belts, pulleys and cutting heads.*
- ▲ *Electrocution from Overhead Power Lines (by contact with or 'flashover' from).*
- ▲ *Being hit by cutting heads or machine arms as they move.*
- ▲ *Becoming trapped between tractor and machine when hitching or unhitching.*
- ▲ *Tractor overbalancing when machine arm is extended.*
- ▲ *Injection of high-pressure oil from hydraulic hoses or couplings.*
- ▲ *Machine overbalancing when freestanding (out of use).*
- ▲ *Road traffic accidents due to collision or debris on the road.*

BEFORE USING THIS MACHINE YOU MUST:

- ▲ *Ensure you read all sections of the operator handbook.*
- ▲ *Ensure the operator is, or has been, properly trained to use the machine.*
- ▲ *Ensure the operator has been issued with and reads the operator handbook.*
- ▲ *Ensure the operator understands and follows the instructions in operator handbook.*
- ▲ *Ensure the tractor front, rear and side(s) are fitted with metal mesh or polycarbonate guards of suitable size and strength to protect the operator against thrown debris or parts.*
- ▲ *Ensure tractor guards are fitted correctly, are undamaged and kept properly maintained.*
- ▲ *Ensure that all machine guards are in position, are undamaged, and are kept maintained in accordance with the manufacturer's recommendations.*
- ▲ *Ensure flails and their fixings are of a type recommended by the manufacturer, are securely attached and that none are missing or damaged.*
- ▲ *Ensure hydraulic pipes are carefully and correctly routed to avoid damage by chaffing, stretching or pinching and that they are held in place with the correct fittings.*
- ▲ *Always follow the manufacturer's instructions for attachment and removal of the machine from the tractor.*
- ▲ *Check that the machine fittings and couplings are in good condition.*
- ▲ *Ensure the tractor meets the minimum weight recommendations of the machine's manufacturer and that ballast is used as necessary.*
- ▲ *Always inspect the work area thoroughly before starting to note obstacles and remove wire, bottles, cans and other debris.*
- ▲ *Use clear suitably sized warning signs to alert others to the nature of the machine working within that area. Signs should be placed at both ends of the work site. (It is recommended that signs used are of a size and type specified by the Department of Transport and positioned in accordance with their, and the Local Highways Authority, guidelines).*
- ▲ *Ensure the operator is protected from noise. Ear defenders should be worn and tractor cab doors and windows must be kept closed. Machine controls should be routed through proprietary openings in the cab to enable all windows to be shut fully.*
- ▲ *Always work at a safe speed taking account of the conditions i.e.: terrain, highway proximity and obstacles around and above the machine. Extra special attention should be applied to Overhead Power Lines. Some of our machines are capable of reach in excess of 8 metres (26 feet) this means they have the potential to well exceed, by possibly 3 metres (9' 9"), the lowest legal minimum height of 5.2 metres from the ground for 11,000 and 33,000 volt power lines. It cannot be stressed enough the dangers that surround this capability, it is therefore vital that the operator is fully aware of the maximum height and reach of the machine, and that they are fully conversant with all aspects regarding the safe minimum distances that apply when working with machines in close proximity to Power Lines. (Further information on this subject can be obtained from the Health & Safety Executive or your Local Power Company).*

- ▲ *Always disengage the machine, kill the tractor engine, remove and pocket the key before dismounting for any reason.*
- ▲ *Always clear up all debris left at the work area, it may cause hazard to others.*
- ▲ *Always ensure when you remove your machine from the tractor that it is left in a safe and stable position using the stands and props provided and secured if necessary.*

WHEN NOT TO USE THIS MACHINE:

- ▲ *Never attempt to use this machine if you have not been trained to do so.*
- ▲ *Never uses a machine until you have read and understood the operator handbook, are familiar with it, and practiced the controls.*
- ▲ *Never use a machine that is poorly maintained.*
- ▲ *Never use a machine if guards are missing or damaged.*
- ▲ *Never use a machine on which the hydraulic system shows signs of wear or damage.*
- ▲ *Never fit, or use, a machine on a tractor that does not meet the manufacturer's minimum specification level.*
- ▲ *Never use a machine fitted to a tractor that does not have suitable front, rear and side(s) cab guarding made of metal mesh or polycarbonate.*
- ▲ *Never use the machine if the tractor cab guarding is damaged, deteriorating or badly fitted.*
- ▲ *Never turn a machine cutting head to an angle that causes debris to be ejected towards the cab.*
- ▲ *Never start or continue to work a machine if people are nearby or approaching - Stop and wait until they are at a safe distance before continuing. WARNING: Some Cutting Heads may continue to 'freewheel' for up to 40 seconds after being stopped.*
- ▲ *Never attempt to use a machine on materials in excess of its capability.*
- ▲ *Never use a machine to perform a task it has not been designed to do.*
- ▲ *Never operate the tractor or machine controls from any position other than from the driving seat, especially whilst hitching or unhitching the machine.*
- ▲ *Never carry out maintenance of a machine or a tractor whilst the engine is running – the engine should be switched off, the key removed and pocketed.*
- ▲ *Never leave a machine unattended in a raised position – it should be lowered to the ground in a safe position on a level firm site.*
- ▲ *Never leave a tractor with the key in or the engine running.*
- ▲ *Never carry out maintenance on any part or component of a machine that is raised unless that part or component has been properly substantially braced or supported.*
- ▲ *Never attempt to detect a hydraulic leak with your hand – use a piece of cardboard.*
- ▲ *Never allow children near to, or play on, a tractor or machine under any circumstances.*

ADDITIONAL SAFETY ADVICE

Training

Operators need to be competent and fully capable of operating this machine in a safe and efficient way prior to attempting to use it in any public place. We advise therefore that the prospective operator make use of relevant training courses available such as those run by the Agricultural Training Board, Agricultural Colleges, Dealers and McConnel.

Working in Public Places

When working in public places such as roadsides, consideration should be paid to others in the vicinity. Stop the machine immediately when pedestrians, cyclists and horse riders etc. pass. Restart only when they are at a distance that causes no risk to their safety.

Warning Signs

It is advisable that any working area be covered by suitable warning signs and statutory in public places. Signs should be highly visible and well placed in order to give clear advanced warning of the hazard. Contact the Department of Transport or your Local Highways Authority to obtain detailed information on this subject. The latter should be contacted prior to working on the public highway advising them of the time and location of the intended work asking what is required by way of signs and procedure. – *‘Non-authorized placement of road signs may create offences under the Highways Act’.*

Suggested Warning Signs Required

“Road works ahead” warning sign with a supplementary “Hedge cutting” plate. “For 1 mile” or appropriate shorter distance may be added to the plate.

“Road narrows” warning sign with supplementary “Single file traffic” plate.

White on blue “Keep right” () arrow sign on rear of machine.*

** Note – this applies to UK Market machines where traffic passes to the right of a machine working in the same direction as the traffic flow. The direction, use and colour of the arrow sign will depend on the country of use and the Local Highway Authorities regulations in the locality.*

Use of Warning Signs

- ▲ *On two-way roads one set of signs is needed facing traffic in each direction.*
- ▲ *Work should be within 1 mile of the signs.*
- ▲ *Work only when visibility is good and at times of low risk e.g.: NOT during ‘rush-hour’.*
- ▲ *Vehicles should have an amber-flashing beacon.*
- ▲ *Ideally, vehicles should be conspicuously coloured.*
- ▲ *Debris should be removed from the road and path as soon as practicable, and at regular intervals, wearing high visibility clothing and before removing the hazard warning signs.*
- ▲ *Collect all road signs promptly when the job is completed.*

Although the information given here covers a wide range of safety subjects, it is impossible to predict every eventuality that can occur under differing circumstances whilst operating this machine. No advice given here can replace ‘good common sense’ and ‘total awareness’ at all times, but will go a long way towards the safe use of your McConnel machine.

VEHICLE / TRACTOR PREPARATION

We recommend vehicles are fitted with cabs using 'safety glass' windows and protective guarding when used with our machines.

Fit Operator Guard (part no. 73 13 324) using the hooks provided. Shape the mesh to cover all vulnerable areas.

Remember the driver must be looking through mesh and/or polycarbonate

glazing when viewing the flail head in any working position - unless the vehicle/ cab manufacturer can demonstrate that the penetration resistance is equivalent to, or higher than, that provided by mesh/polycarbonate glazing. If the tractor has a roll bar only, a frame must be made to carry both mesh and polycarbonate glazing. The operator should also use personal protective equipment to reduce the risk of serious injury such as; eye protection (*mesh visor to EN1731 or safety glasses to EN166*), hearing protection to EN352, safety helmet to EN297, gloves, filter mask and high visibility clothing.

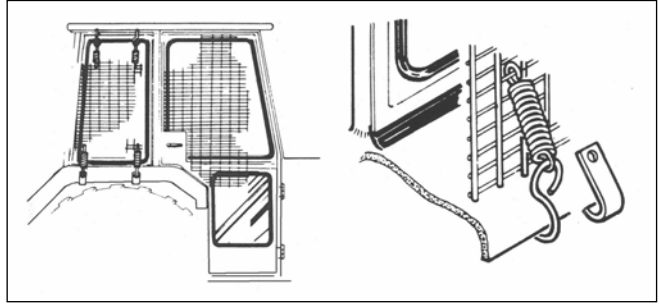

Vehicle Ballast: It is imperative when attaching 'third-party' equipment to a vehicle that the maximum possible stability of the machine and vehicle combination is achieved – this can be accomplished by the utilisation of 'ballast' in order to counter-balance the additional equipment added.

Front weights may be required for rear mounted machines to place 15% of total outfit weight on the front axle for stable transport on the road and to reduce 'crabbing' due to the drag of the cutting unit when working on the ground.

Rear weights may be required to maintain a reasonable amount of rear axle load on the opposite wheel from the arms when in work; for normal off-ground work i.e. hedge cutting this should be 20% of rear axle weight or more for adequate control, and for ground work i.e. verge mowing with experienced operators, this can be reduced to 10%.

All factors must be addressed in order to match the type and nature of the equipment added to the circumstances under which it will be used – in the instance of Power Arm Hedgecutters it must be remembered that the machines centre of gravity during work will be constantly moving and will differ from that during transport mode, therefore balance becomes critical.

Factors that effect stability:

- Centre of gravity of the tractor/machine combination.
- Geometric conditions, e.g. position of the cutting head and ballast.
- Weight, track width and wheelbase of the tractor.
- Acceleration, braking, turning and the relative position of the cutting head during these operations.
- Ground conditions, e.g. slope, grip, load capability of the soil/surface.
- Rigidity of implement mounting.

Suggestions to increase stability:

Increasing rear wheel track; a vehicle with a wider wheel track is more stable.

Ballasting the wheel; it is preferable to use external weights but liquid can be added to

around 75% of the tyre volume – water with anti-freeze or the heavier Calcium Chloride

alternative can be used.

Addition of weights – care should be taken in selecting the location of the weights to ensure

they are added to a position that offers the greatest advantage.

Front axle locking, check with tractor manufacturer.

The advice above is offered as a guide for stability only and is not a guide to vehicle strength. It is therefore recommended that you consult your vehicle manufacturer or local dealer to obtain specific advise on this subject, additionally advice should be sought from a tyre specialist with regard to tyre pressures and ratings suitable for the type and nature of the machine you intend to fit.

PRE-ATTACHMENT

The machine will be delivered in a partially dismantled condition secured with transport strap and banding.

Machine Preparation

Select a firm level site on which to locate the machine.

Remove the transport strap, banding straps, and all loose items.

Fill the reservoir with oil to a level that is approximately 2" (5cm) below the top of the tank. **Do not overfill the tank.**

Refer to the oil chart on the following page for recommended oils – equivalents of may be used providing they match the specification.

The oil tank capacity of this machine is approximately 200 litres (44 Imp. Gallons)

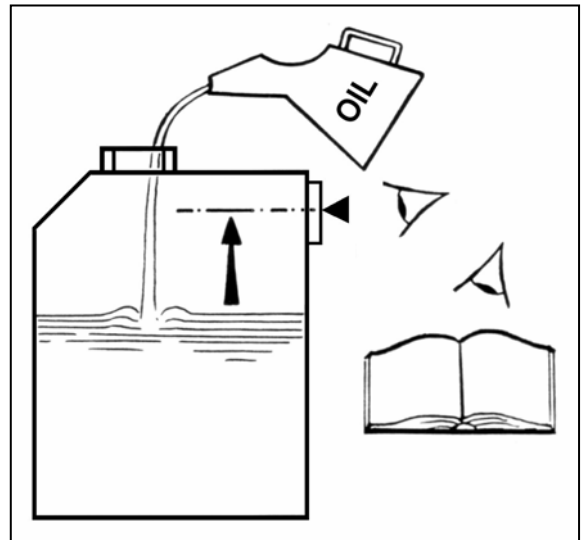

Raise the machine using overhead lifting equipment with a minimum lifting capacity of 1500kg SWL.

Leave in position at this stage.

- Lower the legs and pin in position selecting the locating holes that position the machines gearbox stub axle shaft approximately 3" (7.5cm) below the tractor's PTO shaft.

Note leg pin position used.

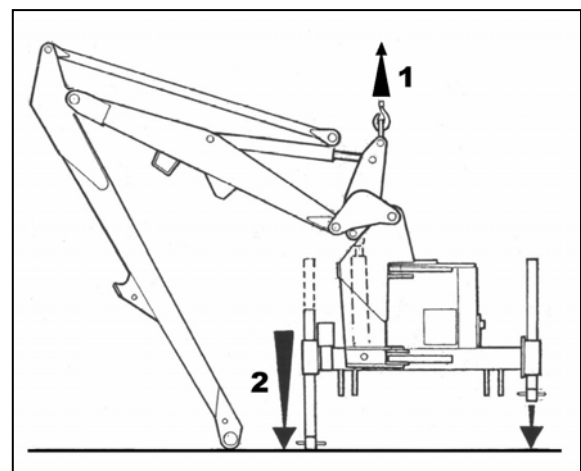

- Unbolt stabiliser from machine and remove the stabiliser nose quadrant pin.

OIL RECOMMENDATIONS

Manufacturer / Supplier	Cold or Temperate Climate	Hot Climate
BP	<i>Bartran 46 Energol HLP-HM 46</i>	<i>Bartran 68 Energol HLP-HM 68</i>
CASTROL	<i>Hyspin AWH-M 46</i>	<i>Hyspin AWH-M 68</i>
COMMA	<i>Hydraulic Oil LIC 15</i>	<i>Hydraulic Oil LIC 20</i>
ELF	<i>Hydrelf HV 46 Hydrelf XV 46</i>	<i>Hydrelf HV 68</i>
ESSO	<i>Univis N 46</i>	<i>Univis N 68</i>
FUCHS (UK/Non UK Markets*)	<i>Renolin 46 Renolin HVZ 46 Renolin CL46/B15* Renolin AF46/ZAF46B*</i>	<i>Renolin 68 Renolin HVZ 68 Renolin CL68/B20* Renolin AF68/ZAF68B*</i>
GREENWAY	<i>Excelpower HY 68</i>	<i>Excelpower HY 68</i>
MILLERS	<i>Millmax 46 Millmax HV 46</i>	<i>Millmax 68 Millmax HV 68</i>
MORRIS	<i>Liquimatic 5 Liquimatic HV 46 Triad 46</i>	<i>Liquimatic 6 Liquimatic HV 68 Triad 68</i>
SHELL	<i>Tellus 46 Tellus T46</i>	<i>Tellus 68 Tellus T68</i>
TEXACO	<i>RandoHD 46 Rando HDZ 46</i>	<i>Rando HD 68 Rando HDZ 68</i>
TOTAL	<i>Equivis ZS 46</i>	<i>Equivis ZS 68</i>

INITIAL ATTACHMENT OF THE MACHINE

- Reverse tractor squarely up to the machine.
- Connect the tractors draft links - selecting the rear most hole in the machines lower link brackets that allow the machine to be mounted without contacting the tractor.
- Ensure that the same hole is used on both sides.
- If necessary fit the spacers supplied (*as required*) to minimise sideways movement of the tractor draft links within the hitch brackets.

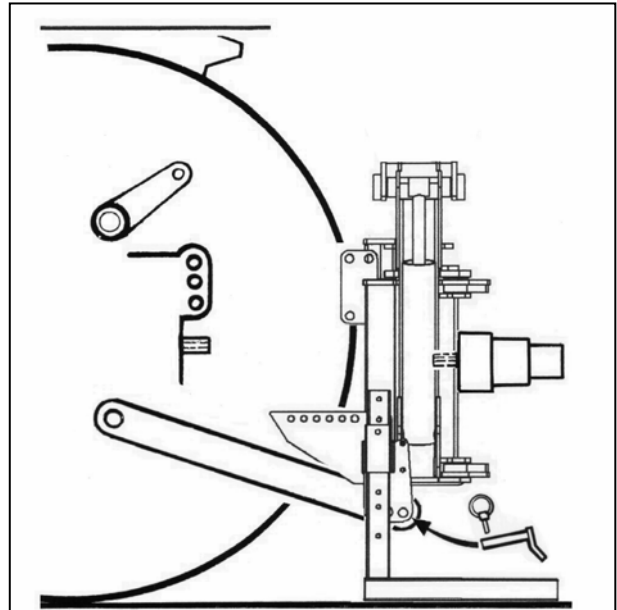

- The lifting equipment may now be removed.
- Fit the stabiliser nose into the tractors top link position. Use the highest position available avoiding any load sensing properties.
- The bolt-on nose of the stabiliser is reversible to accommodate a variety of tractor linkage designs.

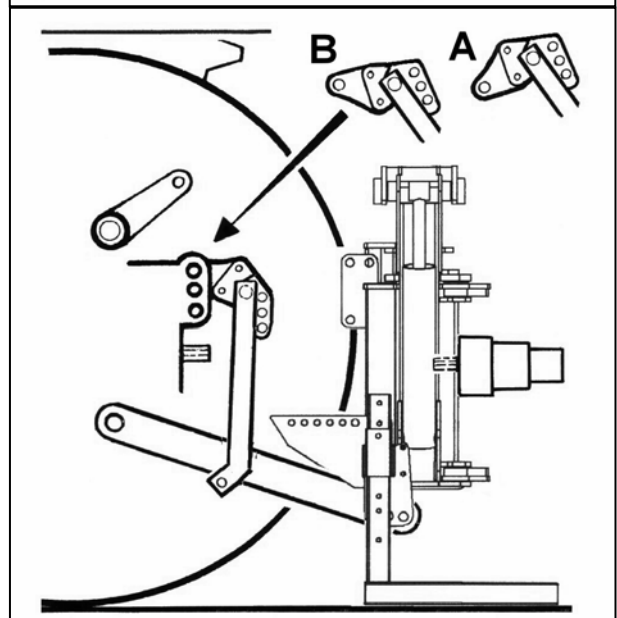

- Stretch out the stabiliser and rest the bottom legs on the lower rail.
- Do not fit stabiliser lower pins at this stage.

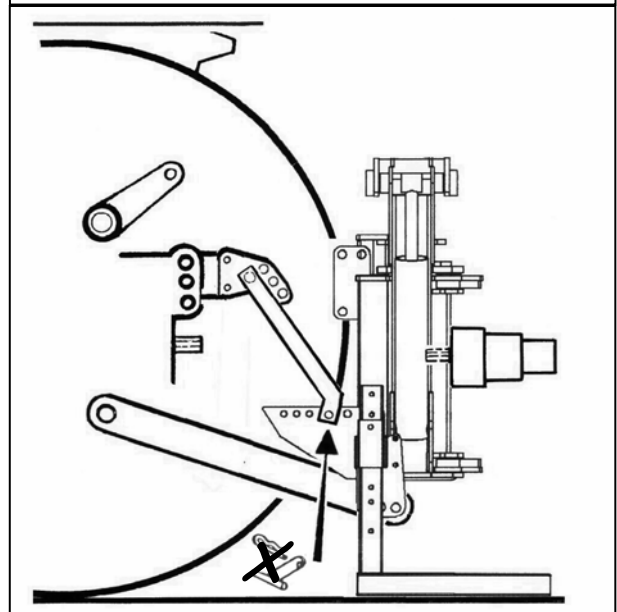

- Fit the machine top link.
- Raise the machine on the tractors linkage to a position where the tractor PTO and the machines gearbox stub shaft are approximately in line with each other. Note: *As lift occurs be aware the machine may tilt slightly.*
-

WARNING

The quadrant lever or machine controls must be operated from the tractor seat. Ensure no one is standing on or between the linkage arms or bars.

- Replace the stabiliser quadrant pin and secure with the 'R' clip.

NOTE: The quadrant pin must be fitted in the lowest hole on the stabiliser in order that it acts as a 'bottom stop' - *this will prevent the machine from dropping when stopped and permit the tractor's inbuilt transport protection system to function correctly during operation and transportation.*

- Ensure the tractor's linkage is in 'position control' and the linkage raised sufficiently to hold the hedgecutter at the correct height and remove the load from the quadrant pin.
Never fit the quadrant pin in a location hole that locks the stabiliser as this can cause damage to the machine and/or tractor.

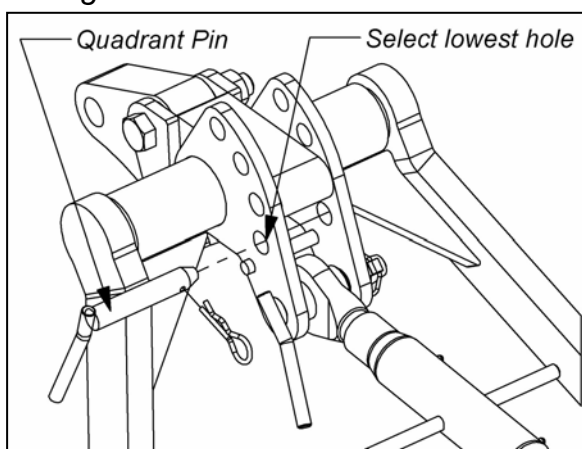

- Adjust the top link to bring the machine frame into the vertical position.

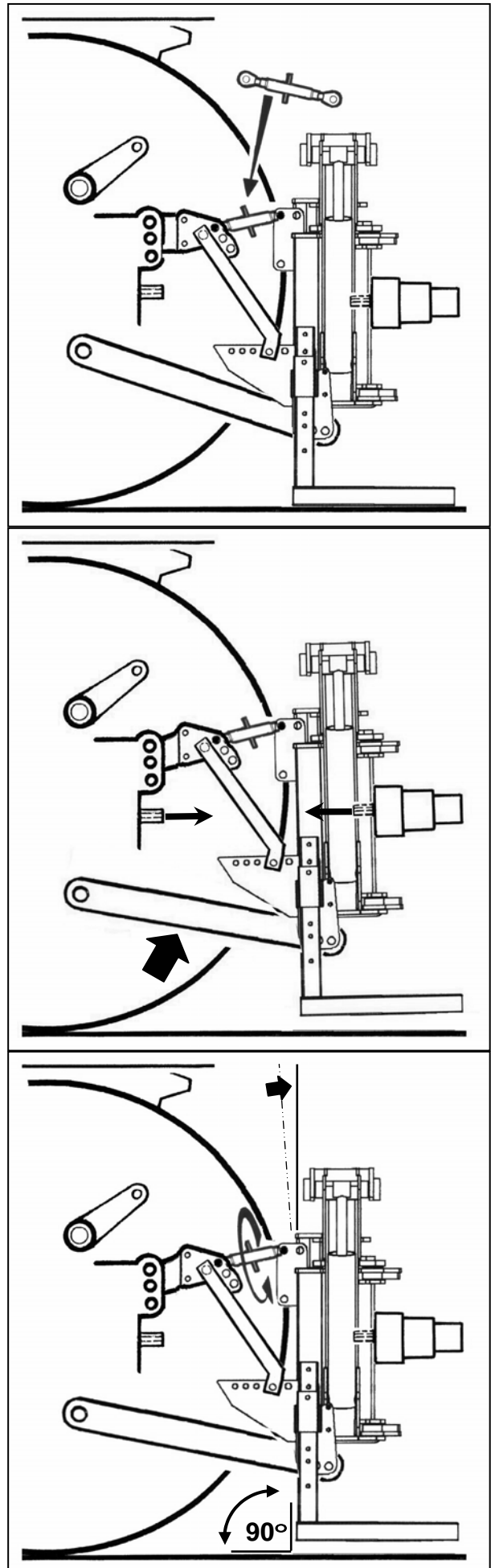

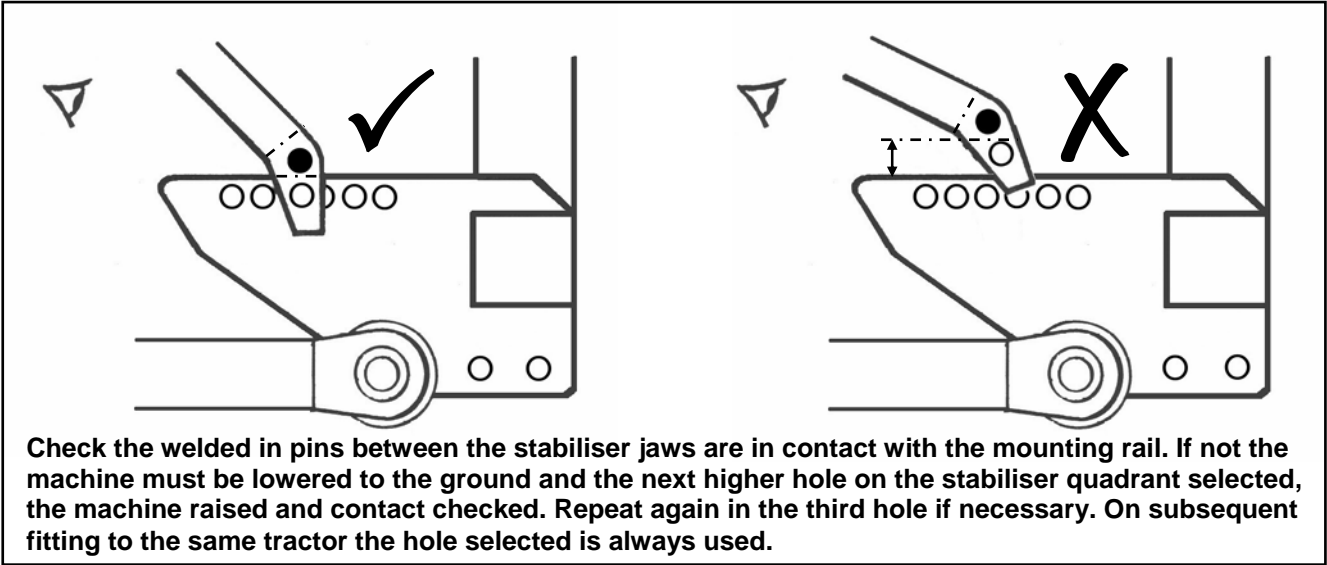

- Fit machine controls into the cab (see page 17)

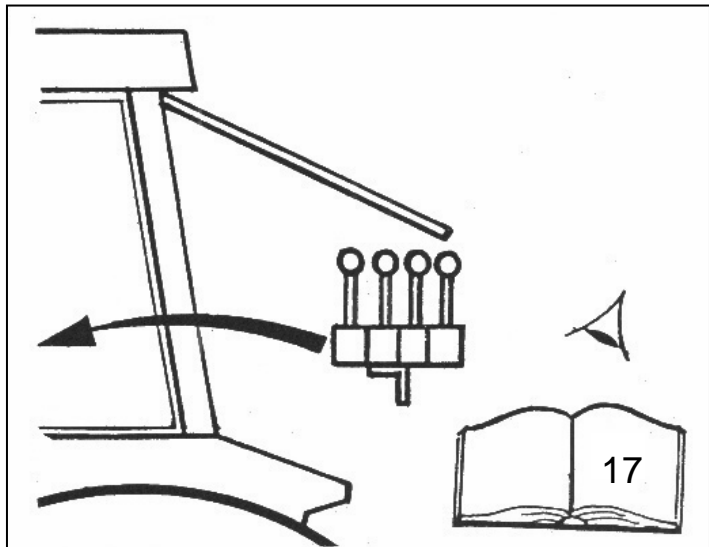

- Measure PTO and cut to dimension shown
- refer to maintenance section for details.

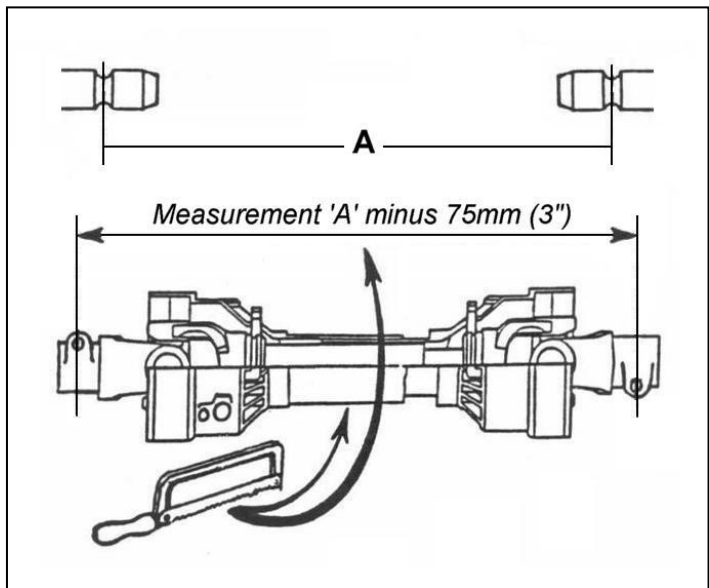

NOTE

For subsequent use on different tractors measure again - there must always be a minimum shaft overlap of 6" (150mm).

- Fit P.T.O. shaft in position.
- Attach torque chains to a convenient location to prevent shaft guards rotating.

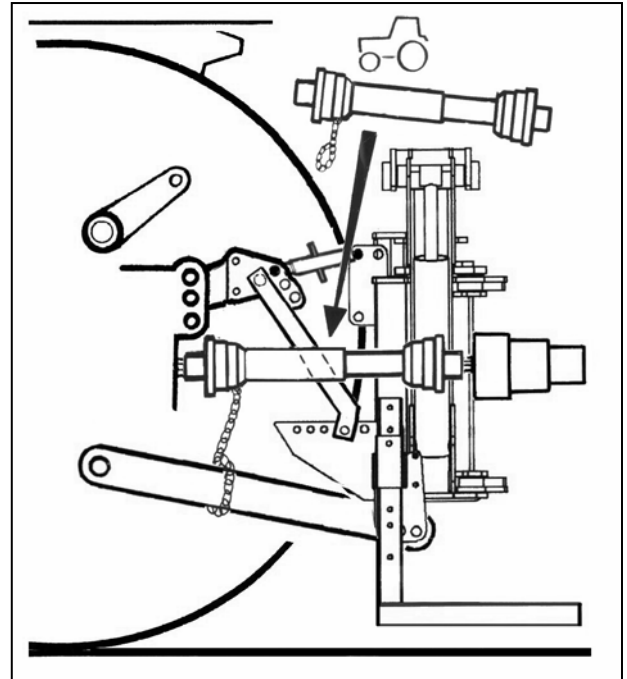

- Ensure the Lift Ram tap and Slew Ram taps are open.

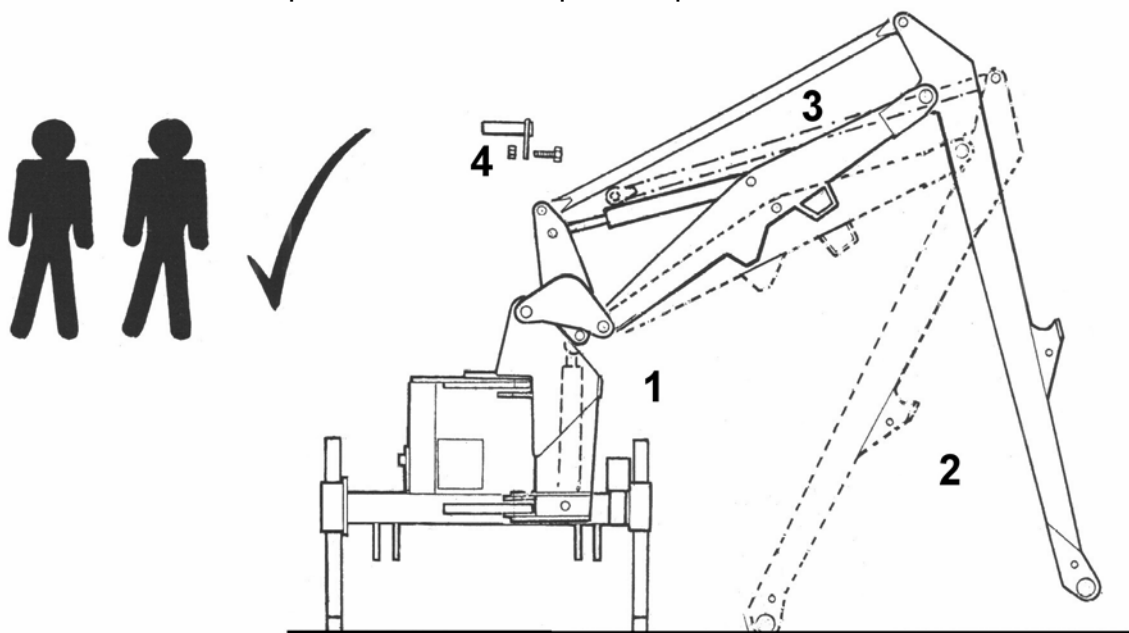

- Request assistance.
- Operate 'lift up' on machine controls sufficient only for the end of the dipper arm to clear the ground.
- Pivot out the dipper arm until the tension link can be connected.

Operate controls to slew the arms towards the rear - only until the frame is horizontal.

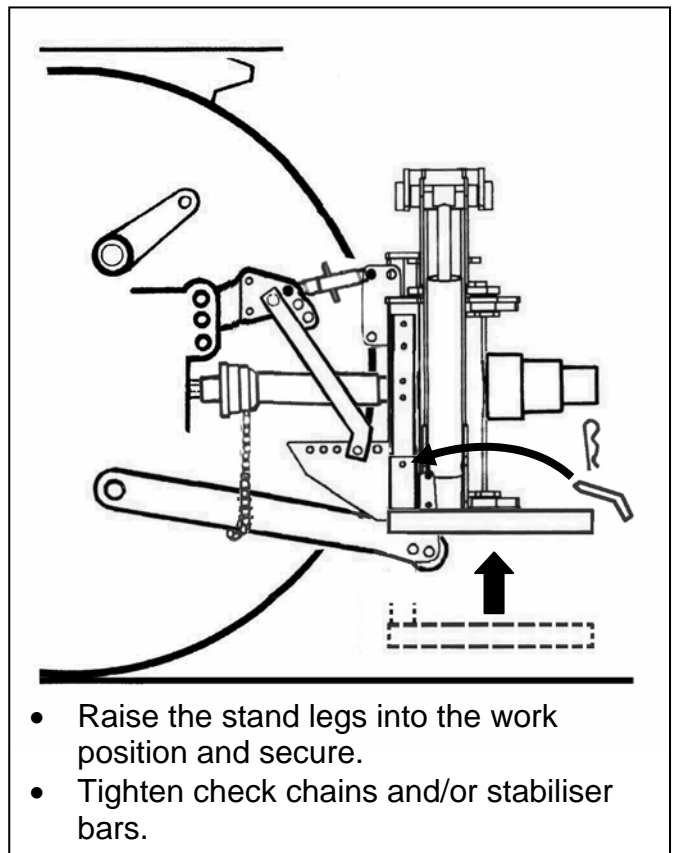
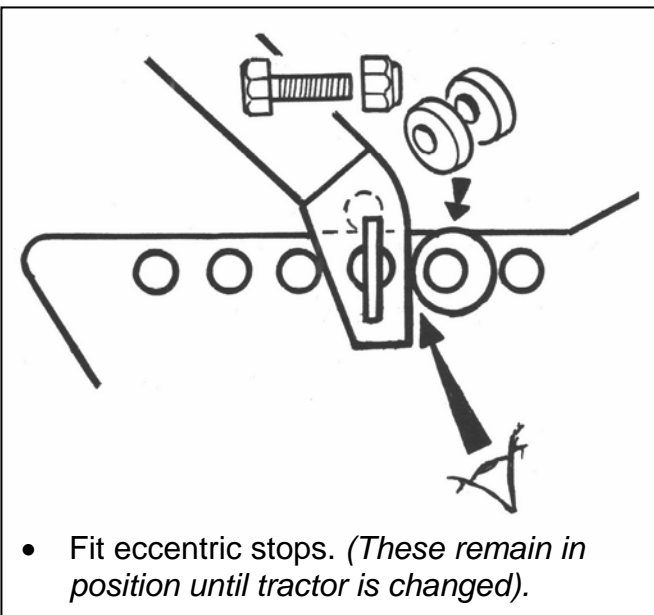
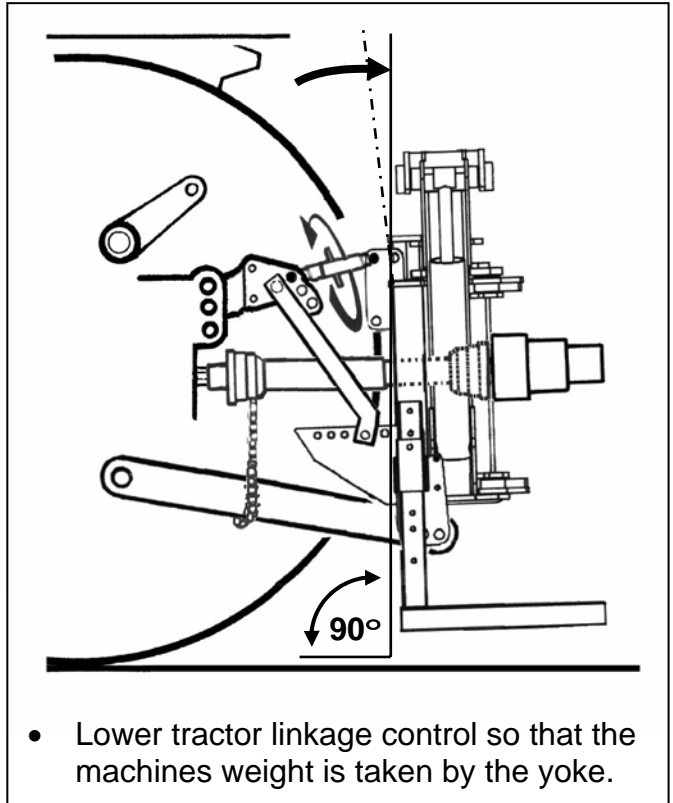
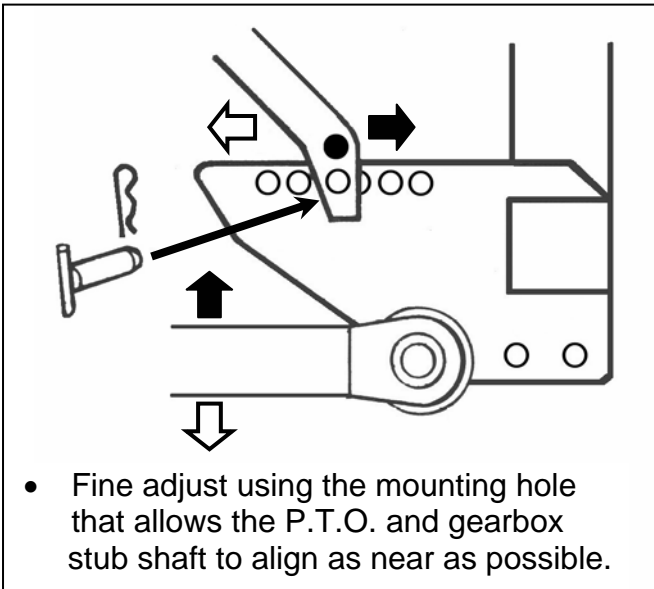

Carefully operate the machine through its full range of movements whilst checking that hoses are not strained, pinched, chaffed or kinked and that all movements are functioning correctly.

Fold the machine into the transport position (*see pages 25 - 27*).

The machine is now ready to proceed to the work site.

FLAILHEAD ATTACHMENT

Operate machine controls to manoeuvre the arm into a position that will enable attachment of the flailhead – the bottom of the hose junction bracket must be parallel with the ground.

Refer to 'Pre operational checks' for correct bolt torque settings.

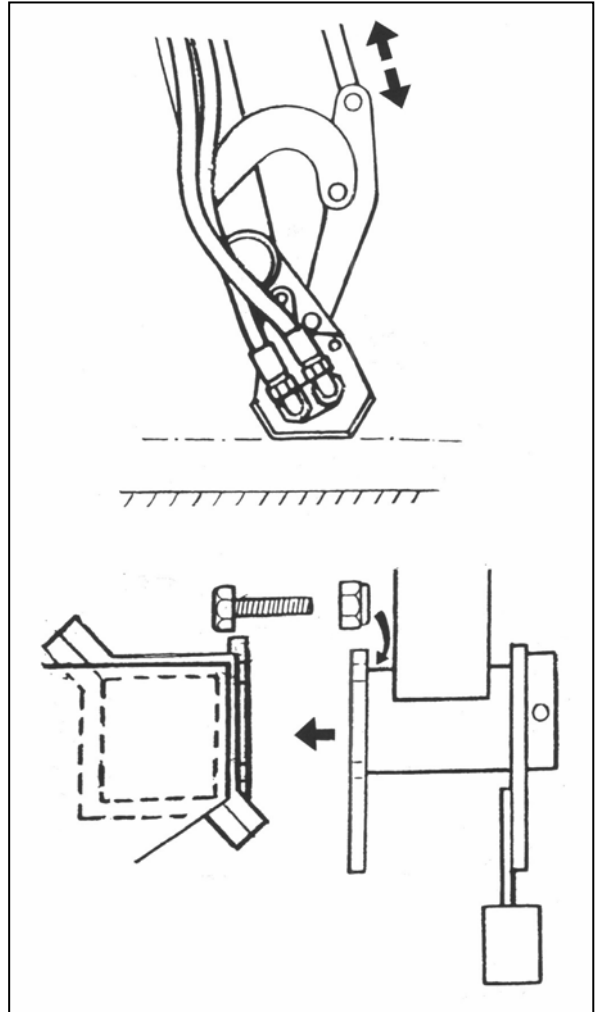

Connect up flail hoses as indicated below.

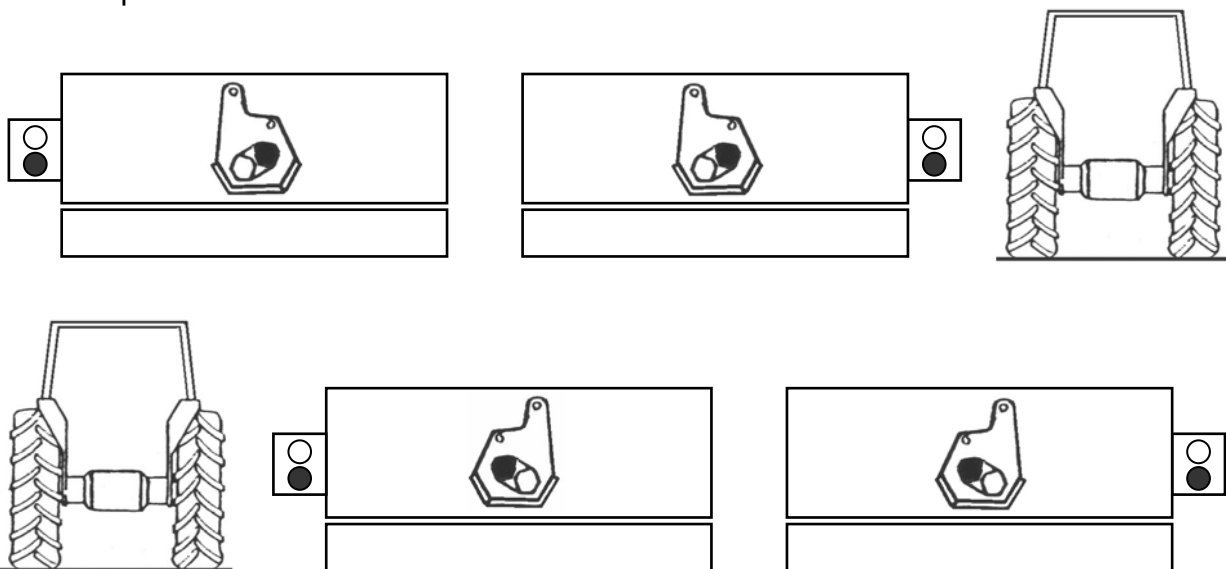

With the arms at half reach and the flailhead clear of the ground carry out final adjustment of the lift arm levelling box to bring the main frame horizontal.

FITTING CONTROL UNIT IN CAB

The control unit is bolted to a mounting bracket, which may be bolted to the mud wing or cab cladding in a convenient location - ensure that no structural member of the cab or roll bar is drilled.

In deciding the final position of the control box remember not to exceed the minimum acceptable bend -radii of 8" for the cables.

The control lever for the cable operated rotor control valve is mounted in a similar fashion adopting the same precautions pertaining to drilling and cable runs.

RUNNING UP PROCEDURE



CAUTION! Before initial use of a new machine, all lubrication points must be greased and the gearbox and oil tank levels checked and where required topped up before attempting to use the machine. See *maintenance section for details*.

Ensure that the rotor control valve is in 'STOP' position, start the tractor and engage the P.T.O. Allow the oil to circulate through the return line filter for about 5 minutes without operation of the Armhead Control Lever.

WARNING

Do not leave the tractor cab or allow anyone to approach the flailhead whilst the machine is running.

Operate the Armhead Levers through their complete range ensuring that all movements are functioning correctly.

Place the flail head at a safe attitude and move the rotor control to the 'START' position - *after initial fluctuation the rotor should settle to a steady speed*. Increase P.T.O. speed to approximately 360 rpm and run for a further five minutes before disengaging and stopping the tractor.

Check the hose runs to ensure that they are free from any pinching, chaffing, straining or kinks.

Re-check the oil level in the tank - top up as necessary if required.

CAUTION

**Do not allow a pump to continue working if the rotor does not turn –
Overheating and serious damage to the pump can occur in a very short time.**

DETACHING THE MACHINE FROM THE TRACTOR

DANGER

READ CAREFULLY BEFORE COMMENCING TO REMOVE THE MACHINE FROM THE TRACTOR

THE ORDER OF THE FOLLOWING STEPS MUST BE FOLLOWED EXACTLY –
DISCONNECTION OF THE TOP LINK **MUST** BE THE LAST OPERATION PRIOR TO
DRIVING THE TRACTOR AWAY FROM THE MACHINE.

WARNING

DO NOT operate the Quadrant Lever or Machine Controls through the rear cab window whilst standing on or amongst linkage components. **ALWAYS SEEK ASSISTANCE.**

REMOVAL PROCEDURE

Select a firm level site for parking the machine.

- Replace parking legs in their sockets and secure in their lowest position.
- Raise the machine on the tractor linkage until the weight is taken off the stabiliser.
- Remove the lower stabiliser pins.
- Unscrew the lift ram tap.
- Lower the machine to be ground.
- Extend the arms and place the flail head on the ground at half reach.
- Disengage tractor P.T.O. and remove.
- Disconnect stabiliser bars or loosen check chains as applicable.
- Unbolt the control unit from the mounting pillar, remove from tractor cab and stow the levers or switchbox clear of the ground.
- Disconnect the stabiliser from the tractors top hitch position. Allow the stabiliser to slide along the rail until it contacts the eccentric stops.
- Remove draft link pins and drive tractor away from machine.

STORAGE OF THE MACHINE

If machine is to be left standing for an extended period of time, lightly coat the exposed portions of the ram rods with grease. Subsequently this grease should be wiped off before the rams are next moved.

If the machine has to be stored outside tie a piece of tarpaulin or canvas over the control assembly, do not use a plastic fertilizer bag as this may lead to rapid corrosion of the component.

SUBSEQUENT ATTACHMENT TO IDENTICAL TRACTOR

Refer to and follow the steps given in the '**initial attachment**' section (page 11).

Connect stabiliser into tractors top hitch position used previously.

- Raise the machine on the tractor linkage until the stabiliser contacts the eccentric stops.
- Fit stabiliser lower pins.
- Mount controls in the tractor cab.
- Fit P.T.O. shaft and attach torque chain to a convenient point to prevent the shaft guard rotating.
- Place arms in work position at half reach and adjust lift arm levelling box to bring frame horizontal.
- Tighten check chains.
- Stow parking legs.
- Fold machine into transport position (see pages 25 - 27).
- Proceed to the work site.

SUBSEQUENT ATTACHMENT TO DIFFERENT TRACTOR

Remove stabiliser and top link from machine and separate.

Refer to and follow the steps given in the '**initial attachment**' section (page 11).

OPERATION

Operator Guard

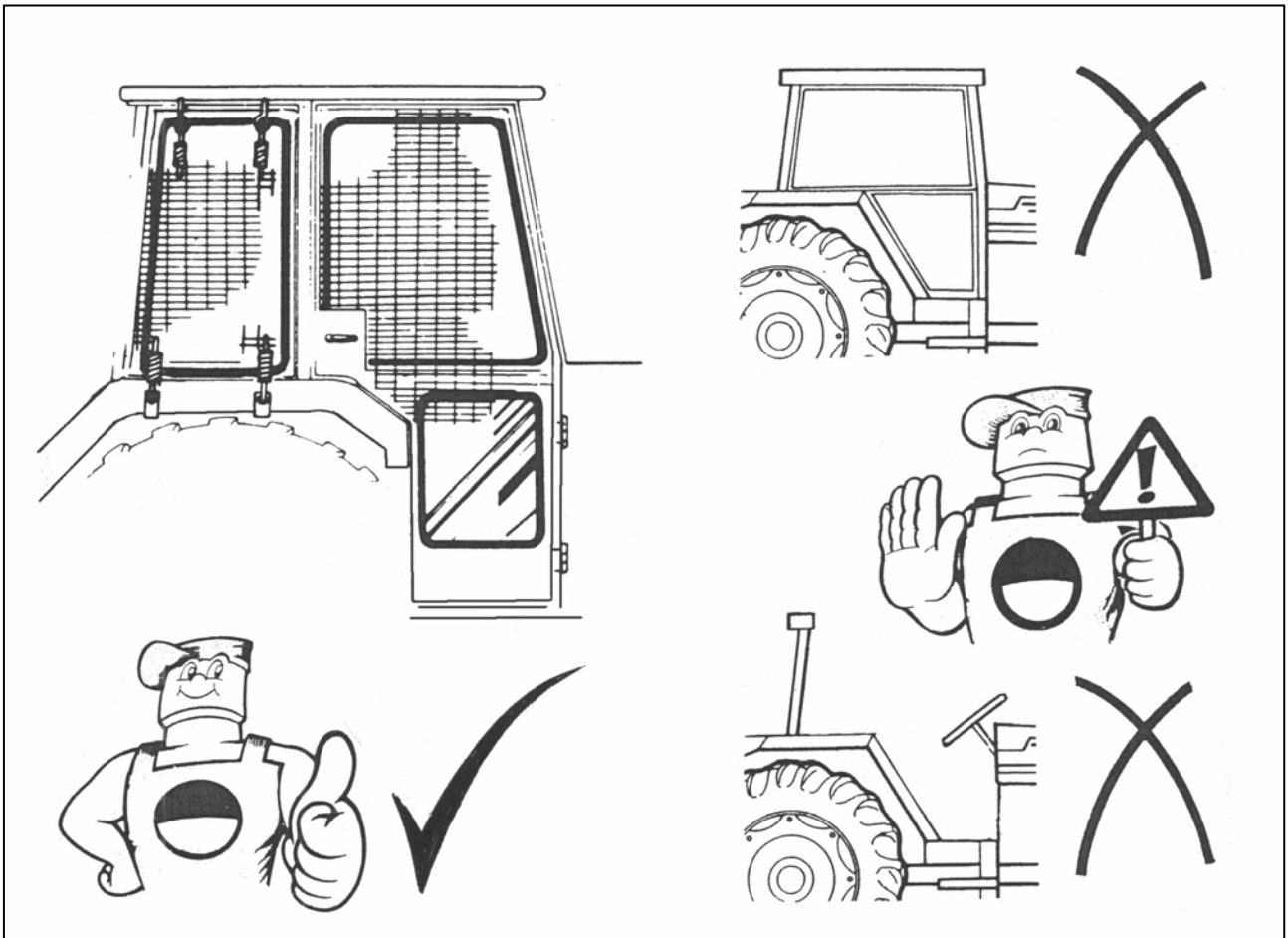

PREPARATION

READ THE BOOK FIRST

Ensure both the Owner and the Operator of this machine has read this book in its entirety and that they are familiar with all aspects regarding its safe use.

Operators of this machine should practice operating it in a clear safe open area, without the rotor running, until they are fully familiar with its controls and operation.

CAUTION

Care must be taken when operating the machine with the flailhead close in, as it will come into contact with the tractor.

MACHINE CONTROLS

Cable Controls – Identification & Function

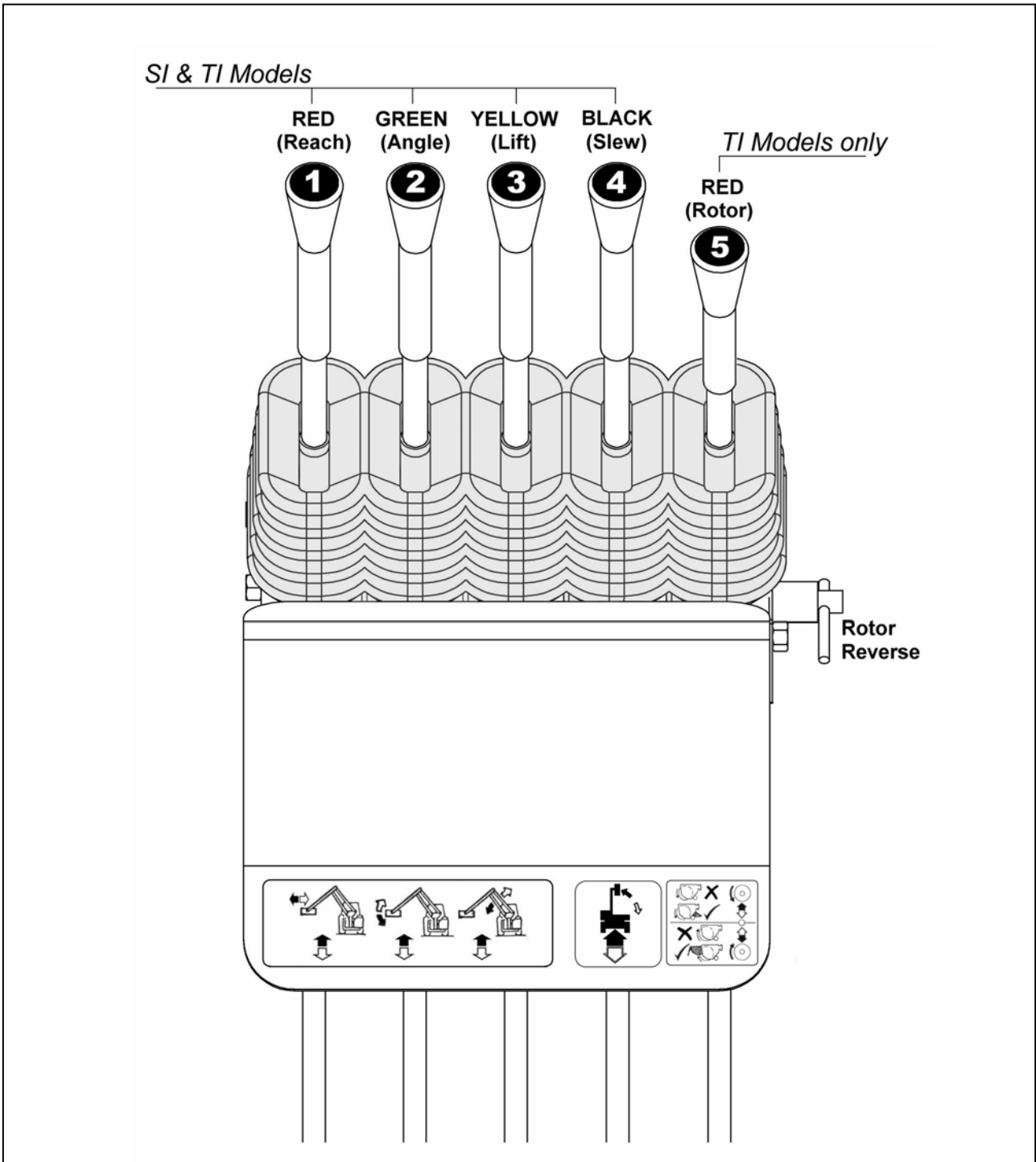

MACHINE CONTROLS

Control & Arm Movements

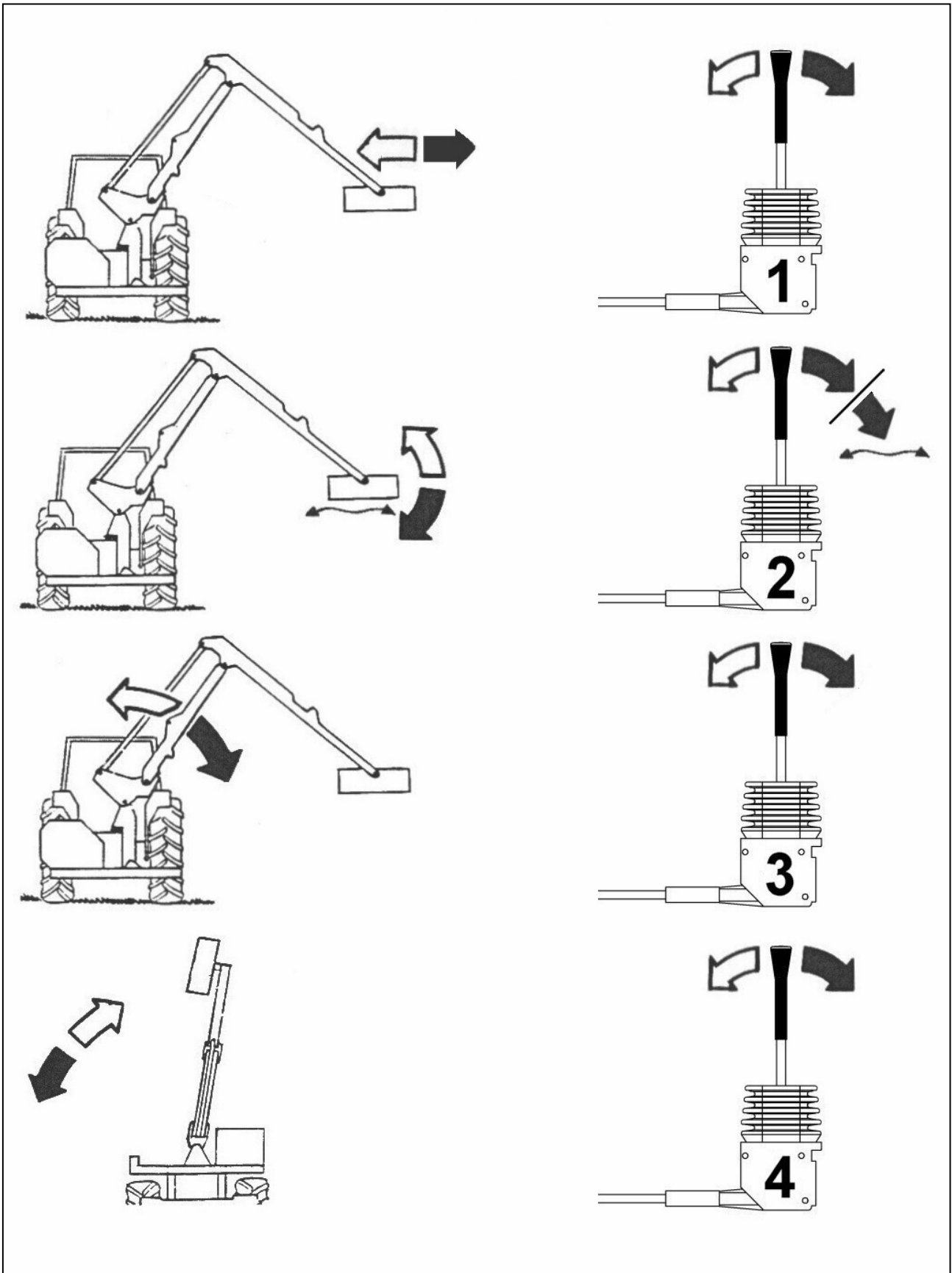

ROTOR CONTROL

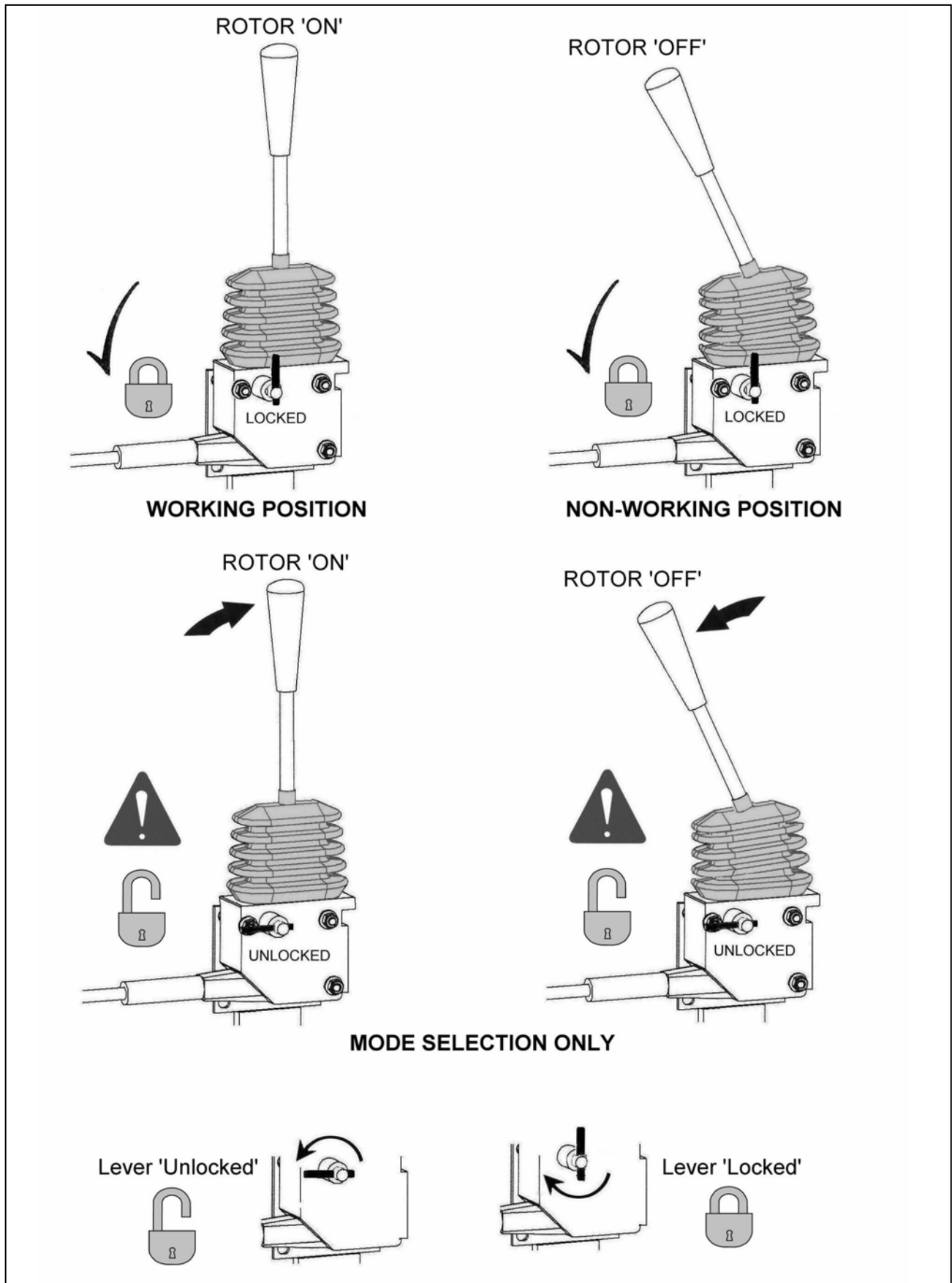

WARNING

Never leave the tractor seat until the Rotor is stationary.
Remember - some cutting heads may 'freewheel' for up to 40 seconds after being stopped.

XTC PROPORTIONAL SWITCHBOX CONTROLS

Machines with XTC Proportional Controls will be supplied with the control unit shown below. The units for both electric and cable rotor machines are identical except that on cable versions the rotor control switches (D & E shown below) will not provide a function as rotor operation will be controlled by a separate cable lever unit (refer to specific cable rotor control page for operation information).



LOCATION & FUNCTION OF CONTROLS

- | | |
|--|--|
| 1. Arm Lift Control | A. Power On/Off |
| 2. Arm Reach Control | B. Auto Reset |
| 3. Flailhead Angle Control | C. Head Float - Angle/Lift (Option) |
| 4. Arm Slew Control | D. Rotor On/Off (Electric RCV models) |
| 5. Tele/Midcut/VFR Control (<i>Applicable models only</i>) | E. Rotor Direction (Electric RCV models) |

Powering the Controls

Activation of power to the control unit is by operation of switch 'A' as shown below:

Press the switch down for Power ON (LED light on)

Press the switch up for Power OFF (LED light off)



ARM OPERATION

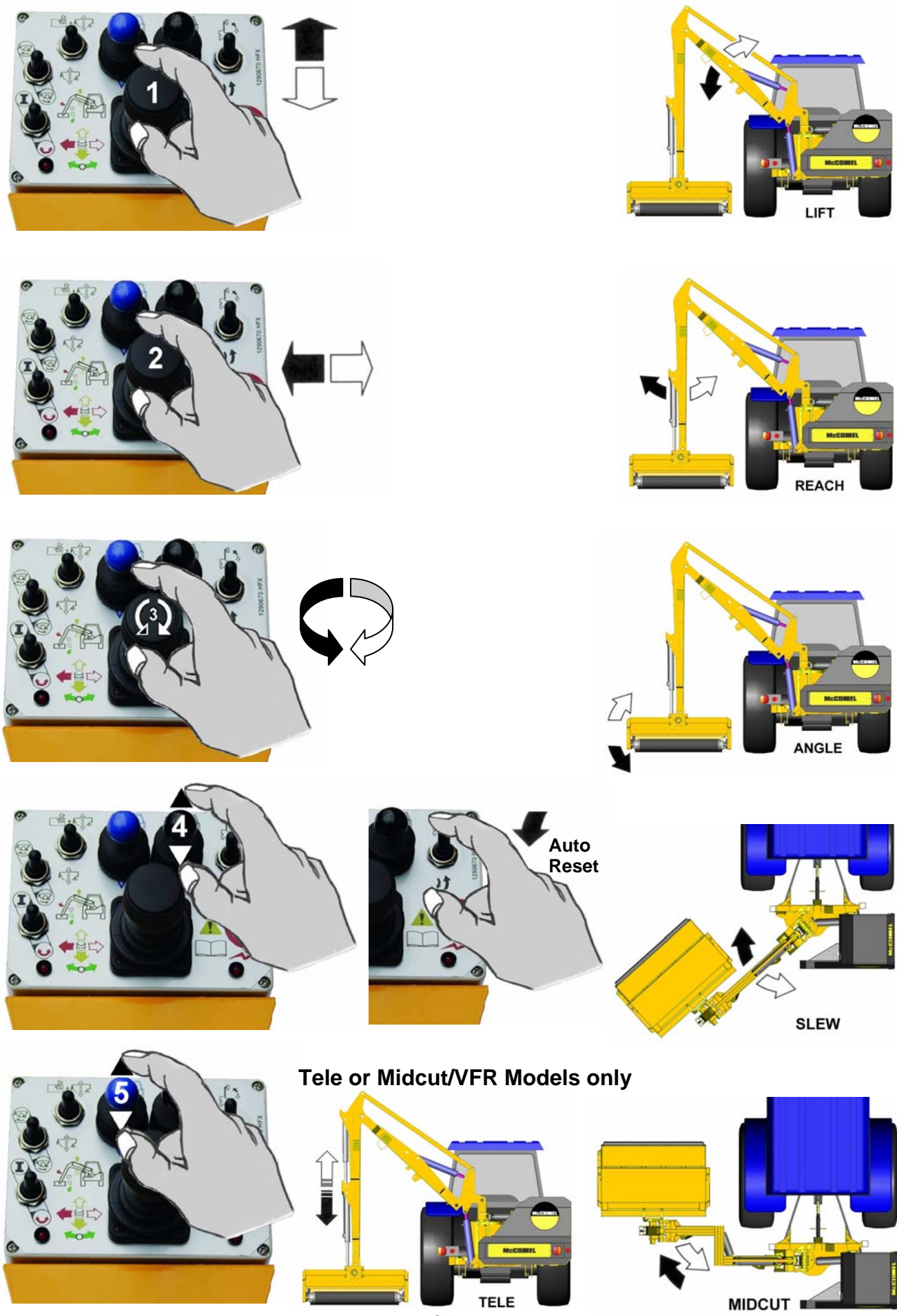

HEAD FLOAT OPERATION (Angle Float standard / Lift Float optional)

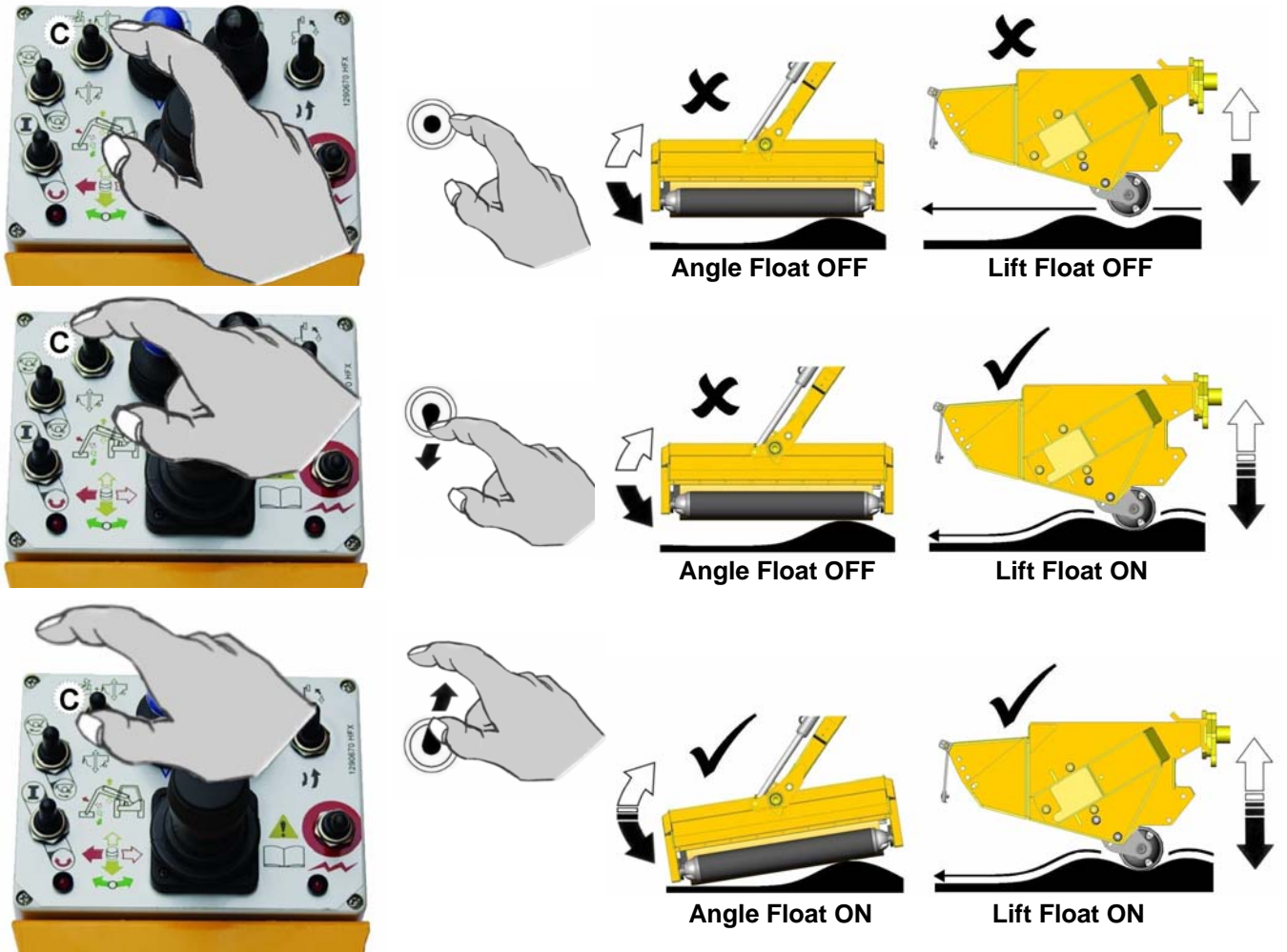

ROTOR OPERATION – Electric Rotor Control Models only

NOTE: The following section relates to machines with Electric Rotor Control only – for Cable Rotor Control models refer to the cable rotor control section.

Selection of Rotor Cutting Direction

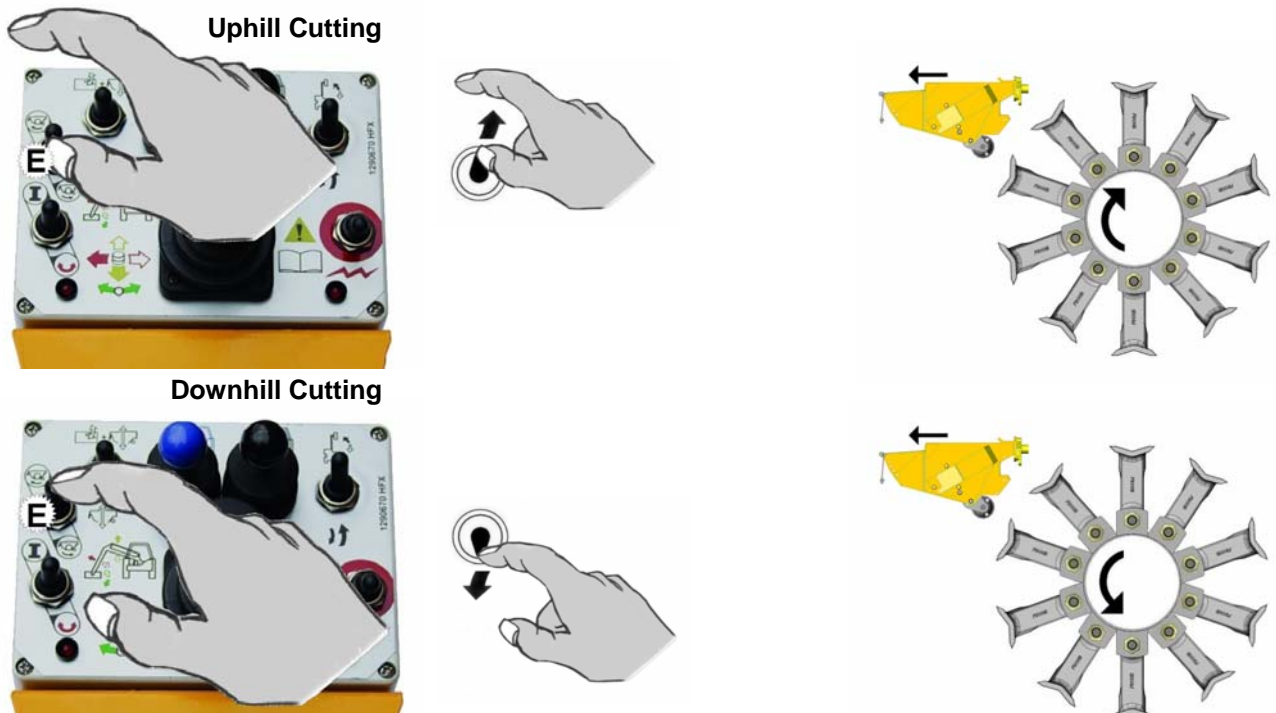

Switching the Rotor On

For safety reasons, to prevent accidental starting of the rotor, the 'Rotor On' switch cannot be activated in a single operation or without first selecting the direction of cut – the procedure for starting the rotor is as follows:

Select the required cutting direction - the Rotor On/Off Switch (D) must then be switched upwards and held in position for a minimum of 8 seconds before switching it into the fully down 'on' position where it will remain until it is switched off. When the switch is moved to the down position the red LED light below the switch will be lit to signify the rotor is on – if the LED does not light the switch was not held in its up position for long enough and the rotor will not have started, repeat the process again holding the switch upwards for a longer period.

Rotor Start

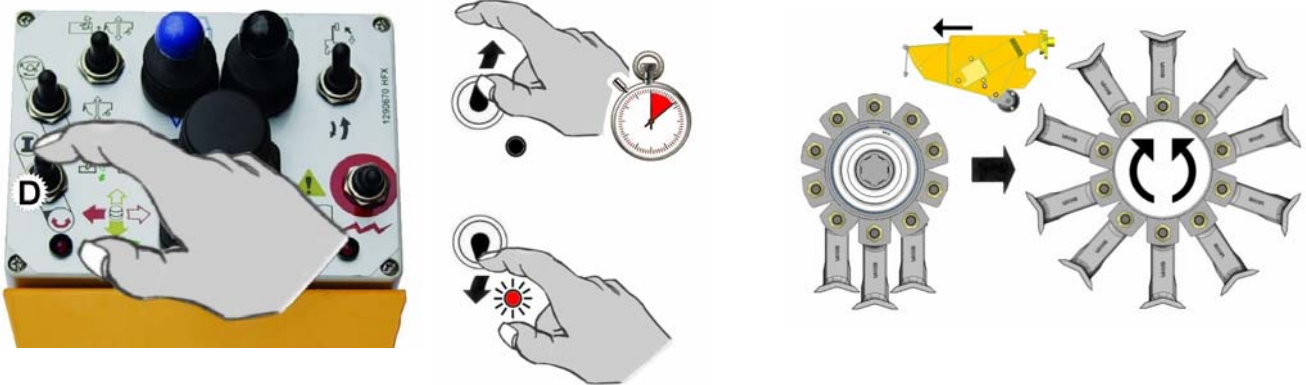

Switching the Rotor Off

Stopping the rotor is performed by switching either the Rotor Power Switch (D) or the Rotor Direction Switch (E) to the central (off) position – the red LED light will go out to signify the rotor has been switched off.



CAUTION: When the rotor is switched off it will continue to 'freewheel' under its own momentum for up to 40 seconds before finally coming to a standstill – do not leave the tractor cab or attempt to approach the flailhead until the rotor has stopped turning completely.

Rotor Stop

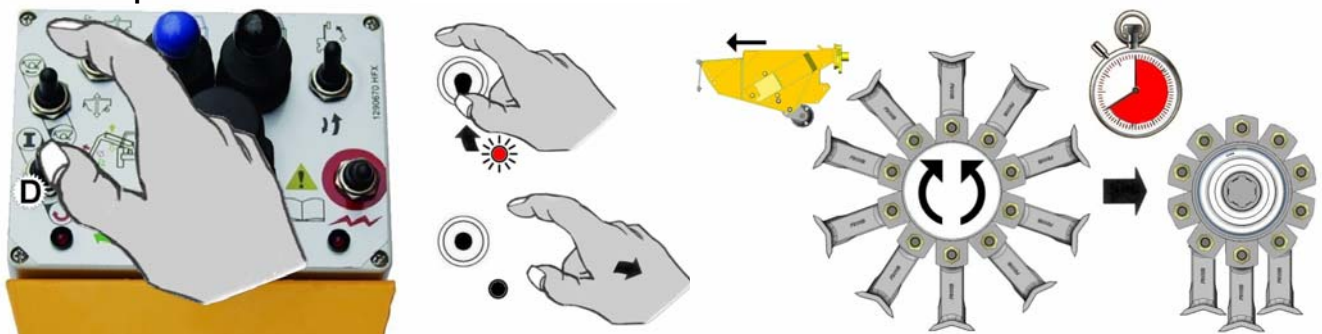

Alternative Rotor Stop

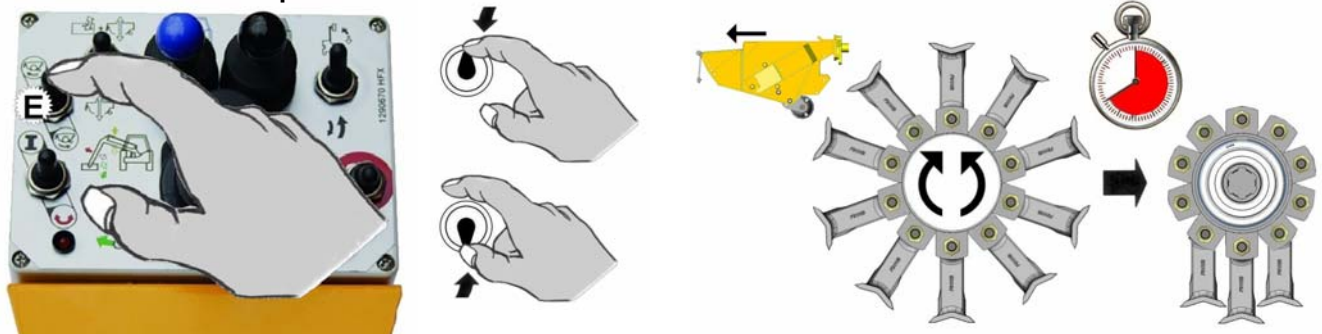

BREAKAWAY

The machine is fitted with a hydraulic breakaway device which protects the structure of the machine should an unforeseen obstacle be encountered.

NOTE

The breakaway function does not relieve the operator of his responsibility to drive carefully - be alert
AVOID OBVIOUS HAZARDS BEFORE CONTACT OCCURS.

Breakaway may occur momentarily during normal work should an extra thick or dense patch of vegetation be encountered. In these instances tractor forward motion may be maintained with care.

Where breakaway has occurred as a result of contacting a post or tree etc. the tractor must be halted and the controls of the machine utilised to manoeuvre the head away from the obstacle. **NEVER CONTINUE FORWARD MOTION TO DRAG THE HEAD AROUND THE OBSTACLE IN BREAKBACK POSITION.**

NOTE

The force required to activate the breakaway system will vary dependent upon the gradient of work.
It will require less force when working uphill and vice versa.

With 'SLEW' selected:

When the slew relief valve setting is exceeded oil is displaced from the slew ram allowing the arm to pivot backwards horizontally and the obstacle to be cleared.

Re-setting the head into the work position is carried out manually by selecting 'SLEW OUT' on the control assembly.

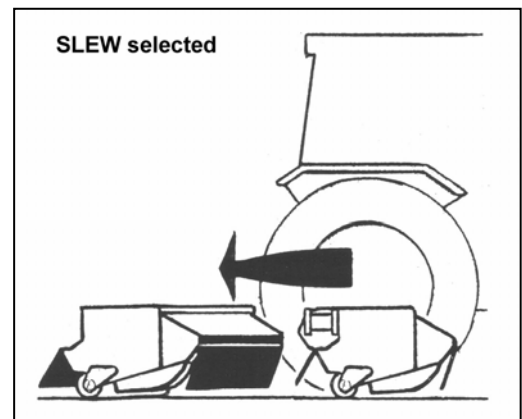

Powered Slew

The slew feature allows a 95° arc of powered arm movement on the working side from right angles to the tractor to 5° beyond the direct line astern.

The feature is required to place the machine in the transport position but can also be used to sweep the arm to and fro whilst cutting awkward areas and corners thus avoiding the need to constantly reposition the tractor. To operate in this way 'SLEW' must be selected on the control assembly.

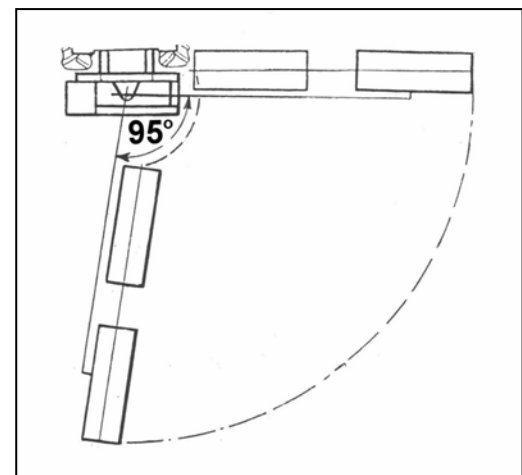

If breakaway occurs the slew motion must be reversed to allow the slew breakaway relief valve to re seat and the ram to become operable again.

CAUTION

Extra care must be taken when working in 'SLEW' mode with the reach fully in -
IT IS POSSIBLE FOR THE FLAIL HEAD TO HIT THE TRACTOR OR MACHINE FRAME.

POSITIONING MACHINE FOR TRANSPORTATION

Moving into the Transport position

- Select 'ROTOR OFF' and wait until the rotor has stopped turning.
- Ensure that 'LIFT' and 'ANGLE FLOAT' are switched off.
- Select 'SLEW' mode on the controls.
- Operate 'SLEW IN'.

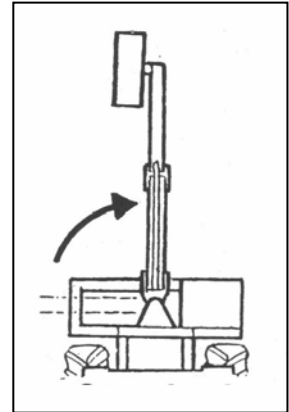

- Operate 'LIFT' and 'REACH' to position the machine – see *diagram opposite*.

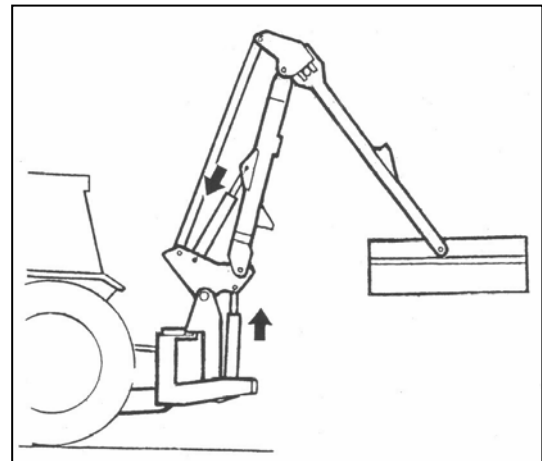

- Operate 'REACH IN' until the dipper arm contacts the transport cradle.

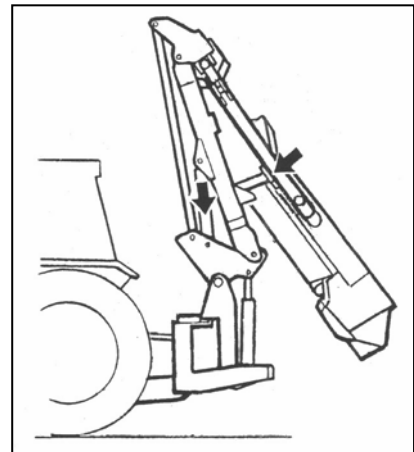

- Select 'LIFT UP' and raise the arms until the tension link is a minimum of 300mm (12") from the tractor cab.
- Operate 'ANGLE' and position the flailhead in as compact position as possible.
- Fully screw in the lift ram and slew ram taps.

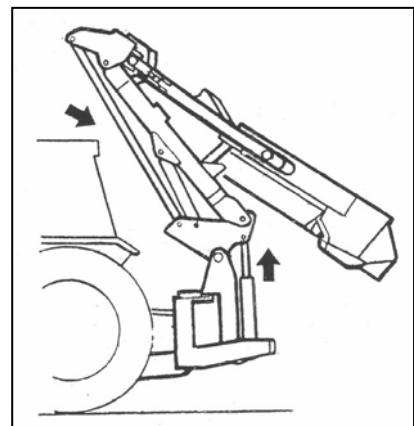

TRANSPORT POSITION

The machine is transported in line to the rear of the tractor with a minimum of 300mm (12") of clearance between the tension link and the rear cross member of the tractor cab.

Transport Position with Flailhead Attached

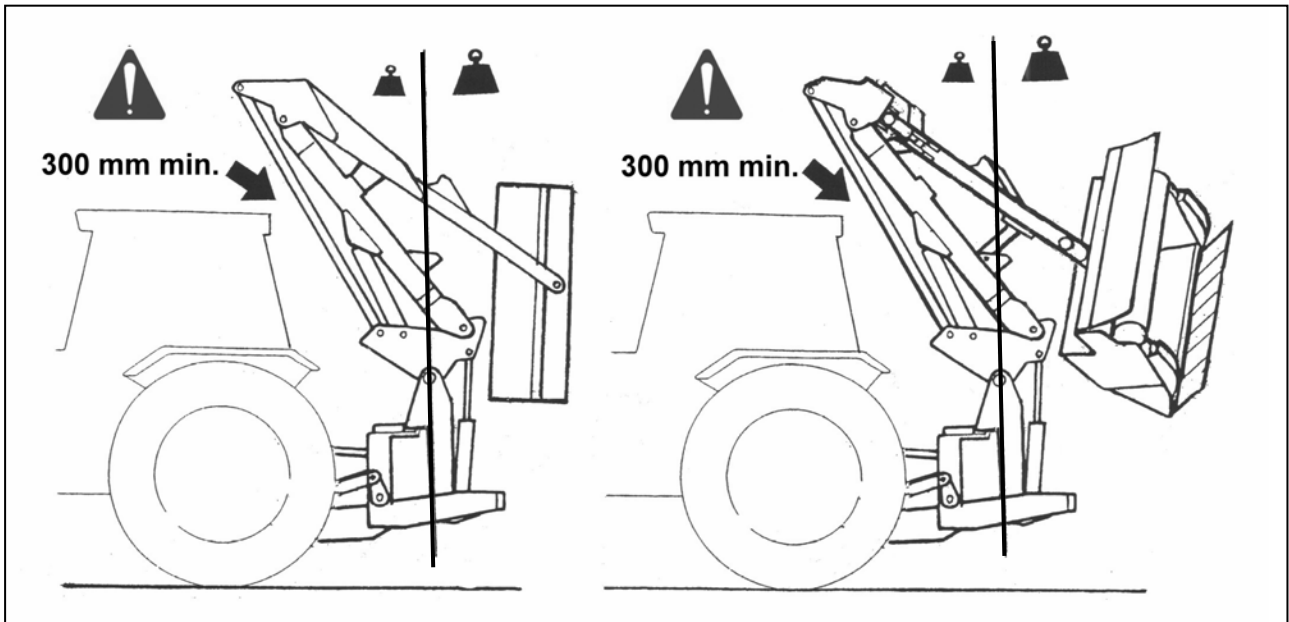

Transport Position with Flailhead Removed

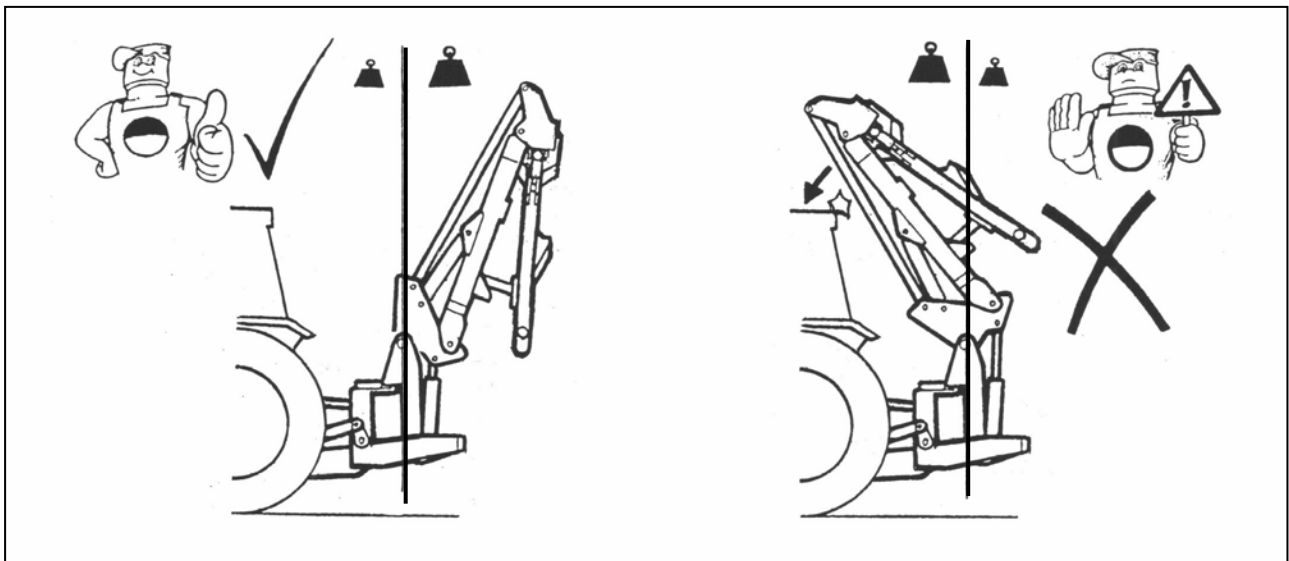

With the flailhead removed the arms of the machine are fully folded but the lift ram remains retracted. If the lift ram is extended the weight of the arms will cause the balance of the machine to go 'over-centre' causing the tension link to crash into the rear cross member of the tractors cab.

WARNING

During Transport the 'Slew' mode must ALWAYS be selected on the Control Unit.

TRANSPORTING

When in transport the PTO must be disengaged and the power to the control box switched off.

The acceptable speed of transport will vary greatly depending upon the ground conditions. In all conditions avoid driving at a speed which causes exaggerated bouncing as this will put unnecessary strain on the tractors top hitch position and increase the likelihood of the tension link contacting the cab rear cross member.

Transport Height

There is no fixed dimension for transport height - It will vary depending on the height that the machine is carried and the degree of arm fold that the rear of the cab will allow.

For the majority of installations the transport height will generally fall between a minimum of 3.45m and a maximum of 3.65m when the machine is correctly folded.

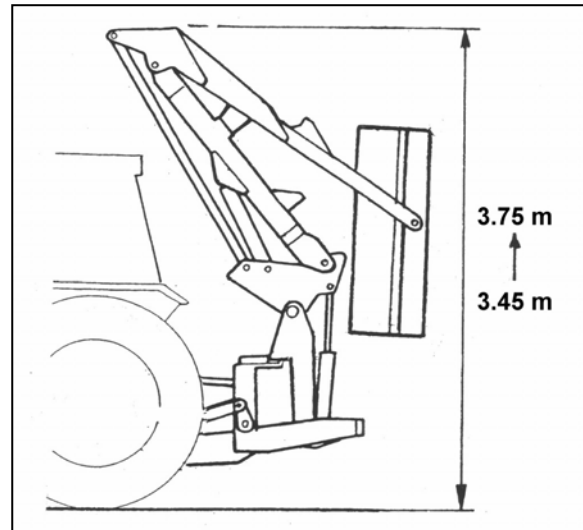

Overhead Obstructions

Always be aware the machine is approximately 4 metres high when folded, take care when manoeuvring in areas with overhead obstacles especially power cables, low bridges etc. or when entering buildings.

Moving from Transport to Work Position

Reverting to the 'work position' is basically a reversal of the previous 'moving into transport' procedure. **Note - remember to unscrew the lift ram tap.**

ROTOR OPERATION

Engaging Drive

Ensure that the rotor control lever is in the 'STOP' position before engaging the PTO shaft. Allow the oil to circulate for a minute or so before operating the armhead levers. Position the flail head in a safe position, increase the engine speed to a high idle and move rotor control lever to 'START'. After initial surging the rotor will run at an even speed.

Rotor Operating Speed

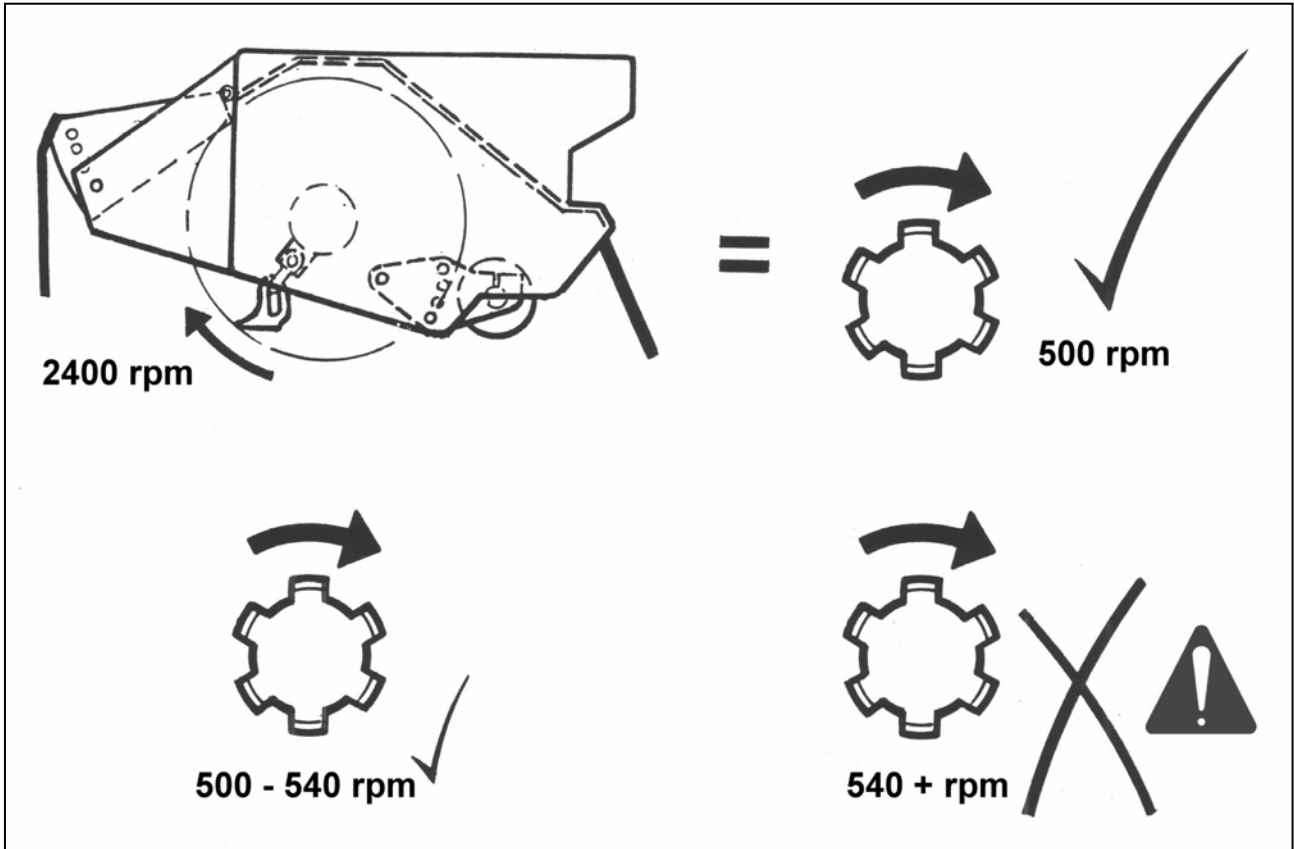

Tractor Forward Speed

The material being cut determines tractor forward speed.

Forward speed can be as fast as that which allows the flail head sufficient time to cut the vegetation properly.

If speed is too high it will be indicated by over frequent operation of the breakaway system, a fall off in tractor engine revs, and a poor finish to the work leaving ragged uncut tufts and poorly mulched cuttings.

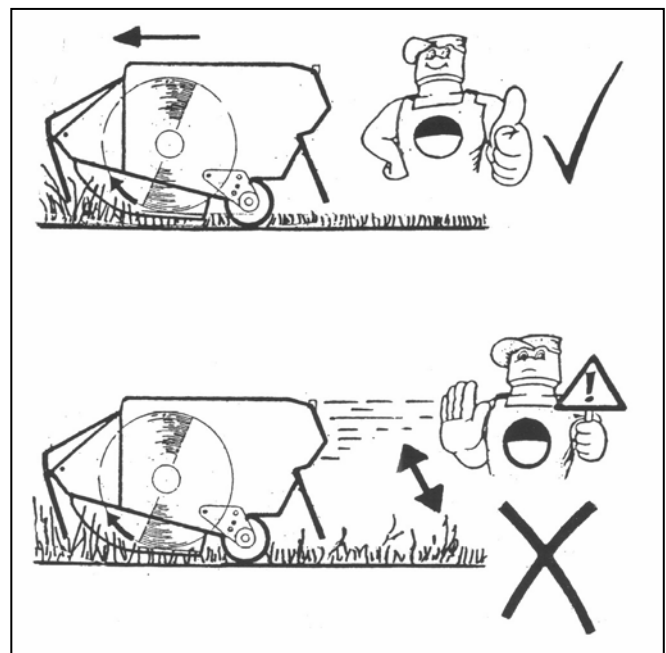

HEDGE CUTTING PROCEDURE

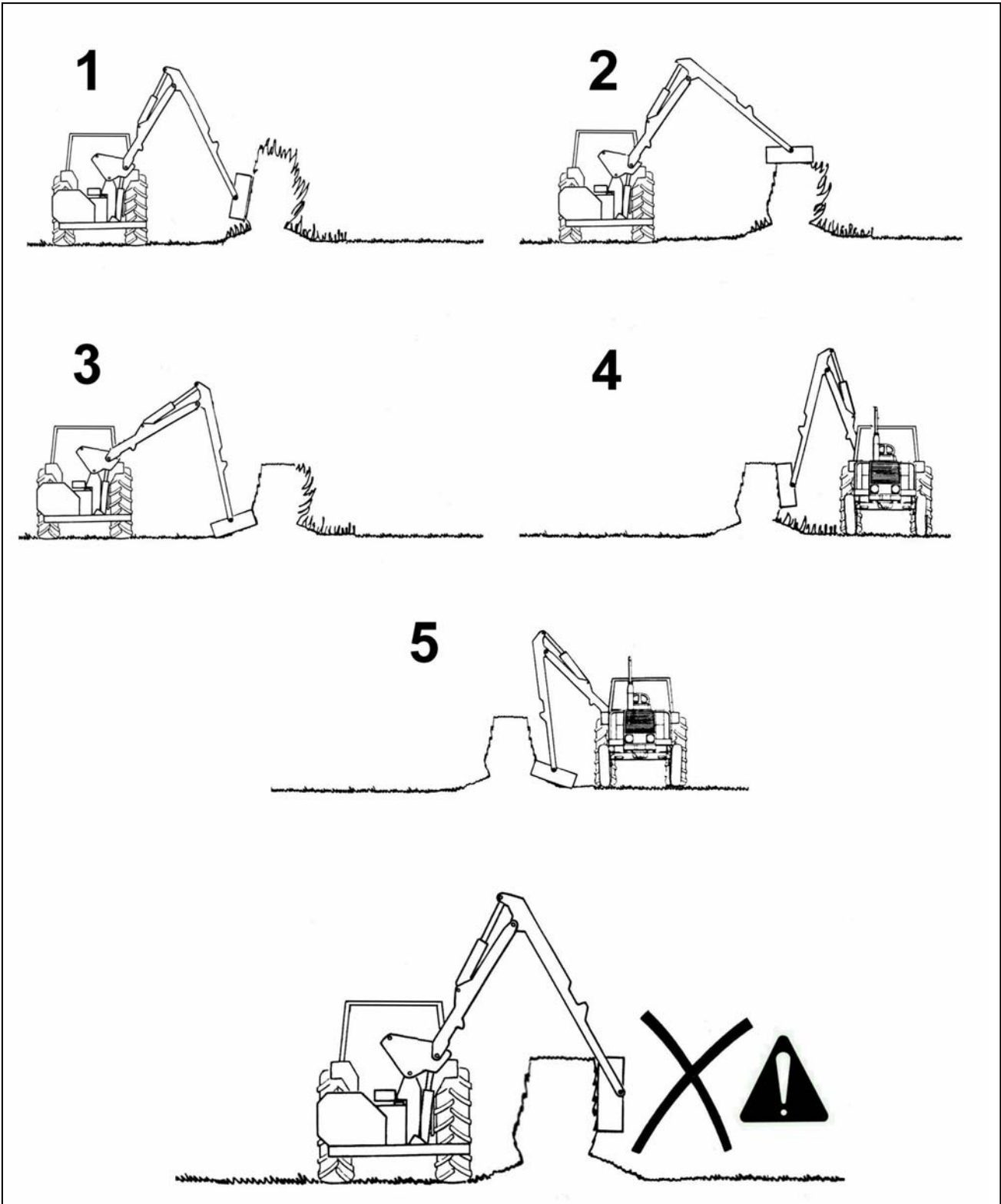

WARNING

Never cut over the far side of the hedge.
It is impossible to see any potential hazards and the position of the flail head will allow the possibility of debris being thrown through the hedge towards the tractor and operator.

SAFE WORKING PRACTICES

Working on Public Highways

When working on the public highway it is the **Operator's responsibility** to familiarise themselves with any national and local regulations concerning this type of activity and to abide by them at all times.

In addition he must remember that there is a potential for debris to be thrown long distances should it escape the head shrouds. In inhabited areas work should only proceed with extreme caution and in all areas bystanders must be kept away from the potential danger area.

WARNING

It is the operator's responsibility to observe all safety regulations and keep bystanders at a safe distance from a working machine.

General Working Practices

It is the Operator's responsibility to develop safe working procedures.

ALWAYS:

- ▲ Be aware of hazards in the vicinity.
- ▲ Make sure all guards are in position and in good condition.
- ▲ Disengage P.T.O. before stopping the engine.
- ▲ Wait until the flail has stopped running before leaving the tractor seat.
- ▲ Disengage the P.T.O. and stop the tractor engine before making any adjustments.
- ▲ Check frequently that all nuts and bolts are tight.
- ▲ Keep bystanders at a safe distance.

CUTTING PRECAUTIONS

Always inspect the work area prior to cutting to remove hazardous material and note any immovable objects.

Working on Adverse Slopes

When working high with the reach fully in it is possible for the main arm balance to go 'over-centre' and take the weight off the lift ram - a restrictor in the gland connection of the lift ram prevents sudden unpredictable movements should this occur.

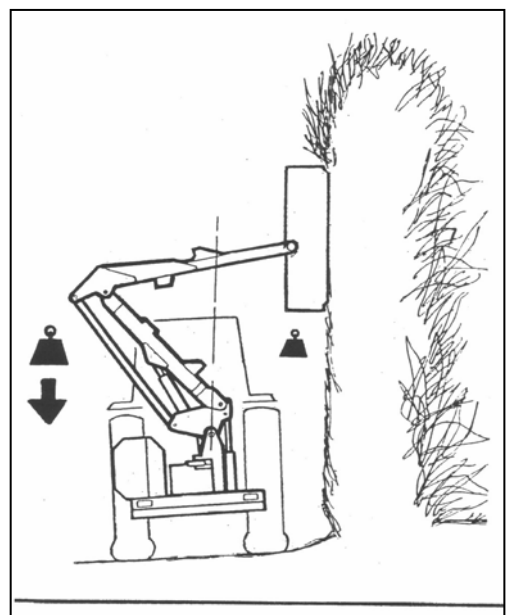

HIGH VOLTAGE CABLES

WARNING!

Depending on the voltage of the cables and the weather conditions there is a danger of 'electric flashover' if the head or arms of the machine approach the cables too closely.

Always maintain a minimum clearance distance of 1.5m when operating near high voltage cables - If in any doubt consult your local electric company regarding a safe procedure for work in these situations.

Always be aware the machine is approximately 4 metres high when folded, take care when manoeuvring in areas with overhead obstacles especially power cables, low bridges etc. or when entering buildings.

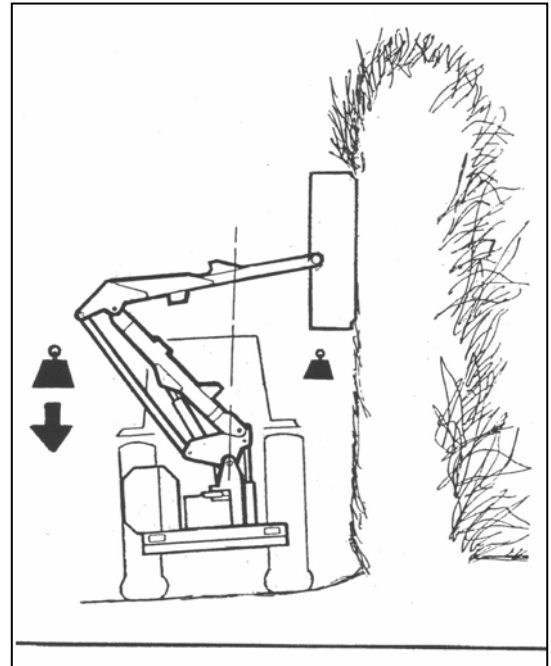

LIFT FLOAT KIT – *Optional Extra for Ground Cutting*

Fitting Location

The hydraulic float kit should be mounted to the special bracket in such a position that it does not foul any other component during the slewing movement of the machine.

Power Supply

The switch can be mounted in a convenient location within the tractor cab and the supply cable from the poppet valve solenoid connected into the tractor's ignition system - *the brown lead is positive and the blue lead is negative.*

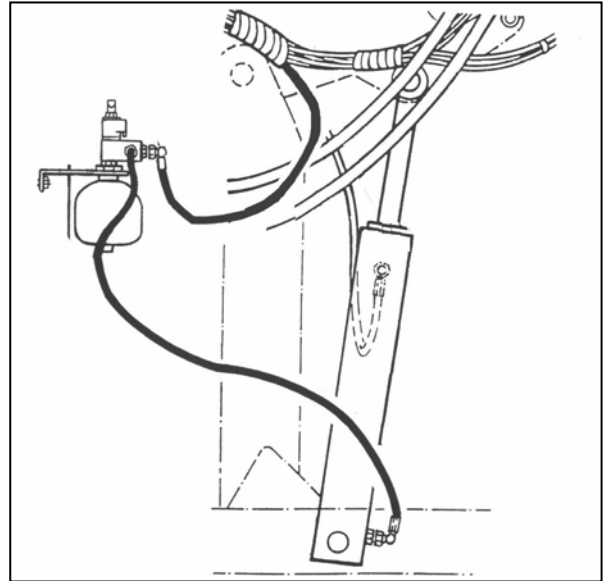

MAINTENANCE

Lubrication Points

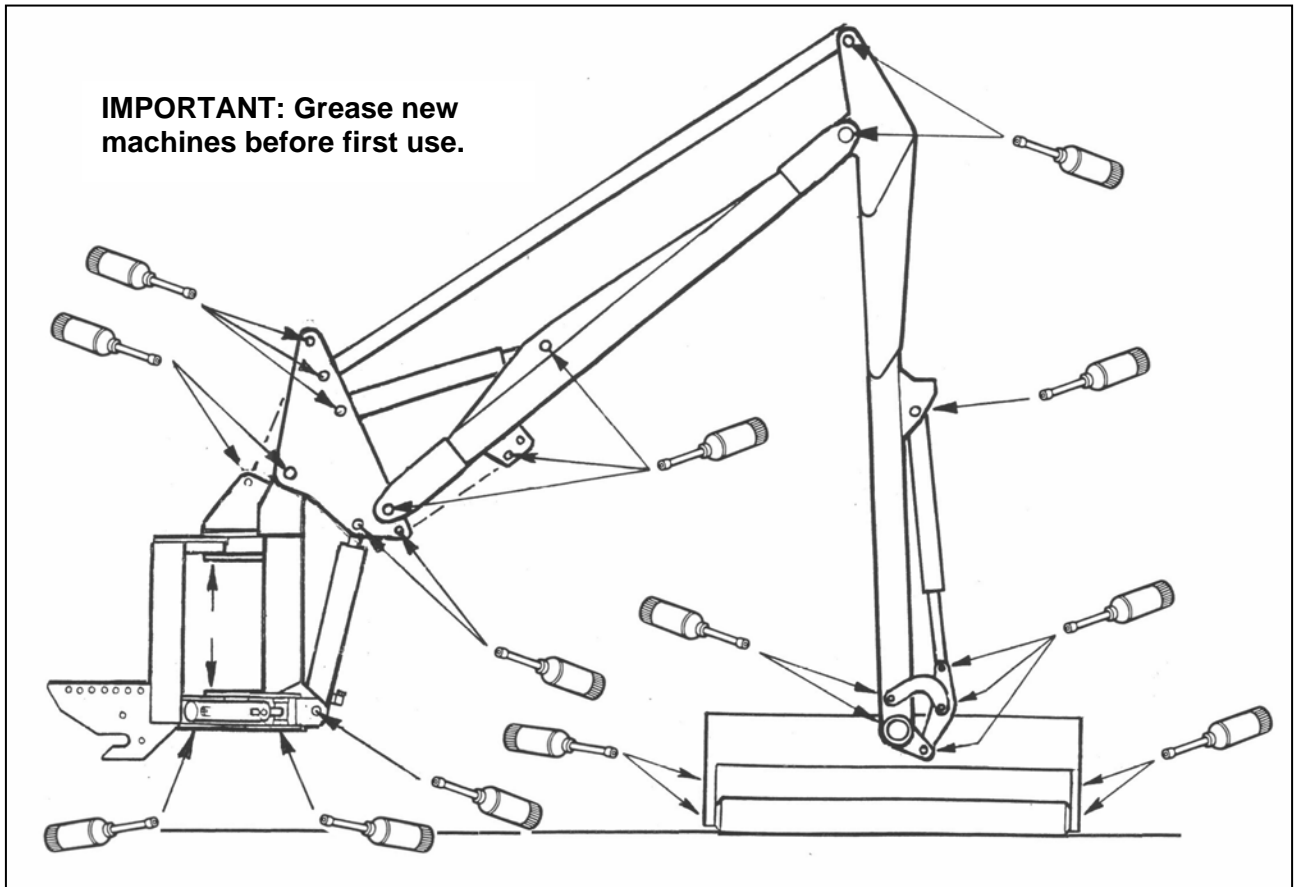

All points should be greased on a daily basis and prior storage of the machine. New machines must be greased prior to first use.

PTO Shaft

Regularly check the PTO guards for damage and ensure that the 'anti-rotation' chains are in place and their anchor points are in good condition.

Do not operate the machine with damaged guards - *replace suspect items immediately.*

PTO Lubrication

Lubricate the PTO Shaft at the points indicated below, at the intervals stated using general-purpose lithium based grease.

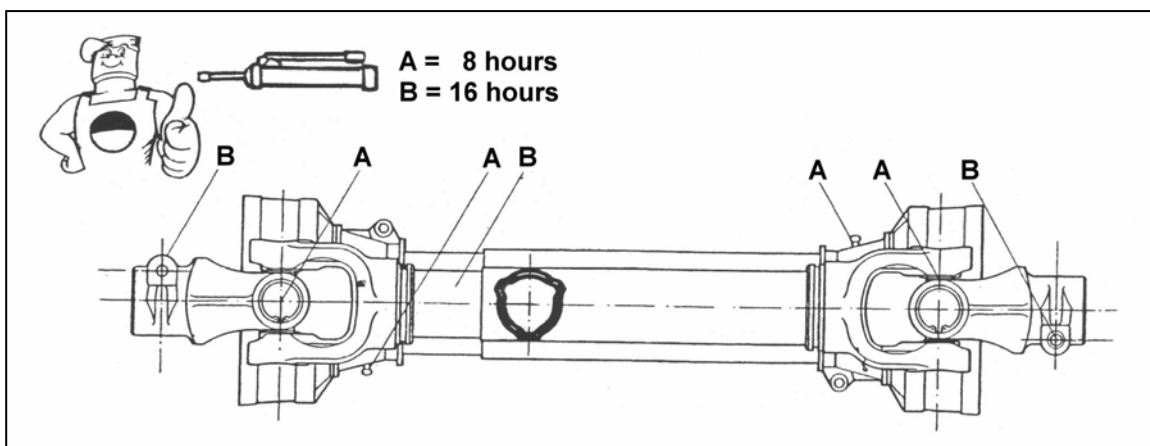

HYDRAULIC SYSTEM

Oil Supply

Check the oil level in the reservoir daily.

No fixed time period can be quoted for oil changes as operating conditions and maintenance standards vary so widely. Burnt and scorched oil odours and the oil darkening and thickening are all signs of oxidation and indicate the oil should be changed. Moisture that results from condensation can become entrapped in the oil and cannot be removed by filtration so water contamination is progressive.

Contamination of the oil can be reduced by:

- ✓ Cleaning around the reservoir cap before removal, and keeping that area clean.
- ✓ Using clean containers when replenishing the system.
- ✓ Regular servicing of the filtration system.

Filtration Maintenance

The machine is protected by a 125-micron suction strainer and a low-pressure 10-micron full flow return line filter.

Suction Strainer

The strainer is permanently fixed within the reservoir.

Should symptoms of pump cavitation or spongy intermittent operation occur the tank must be drained and flushed out with a suitable cleaning agent such as clean diesel oil.

Return Line Filter

The elements should be changed after the first 50 hours of work and thereafter at 500-hour intervals. It is important to note hours worked as if the filter becomes blocked an internal by-pass within the canister will operate and no symptoms of filter malfunction will occur to jog your memory.

PTO Gearbox

Refill with 0.5L of SAE 80 or ISO 100 at the following intervals:

- After an initial 50 hours.
- Thereafter annually or at 500-hour intervals - *whichever occurs earliest.*

HYDRAULIC HOSES

The condition of all hoses should be carefully checked during routine service of the machine. Hoses that have become chaffed or damaged on their outer casing should be securely wrapped with waterproof adhesive tape to stop the metal braid from rusting. Hoses that have suffered damage to the metal braid should be changed at the earliest possible opportunity.

Hose Replacement

- Replace one hose at a time to avoid the risk of wrong connections.
- When the hose is screwed to an additional fitting or union, use a second spanner on the union to avoid breaking both seals.
- Do not use jointing compound on the threads.
- Avoid twisting the hose. Adjust the hose line to ensure freedom from rubbing or trapping before tightening hose end connections.

Before changing hoses study the installation - these are carefully calculated so as to prevent hose damage during operation. Always replace hoses in exactly the same manner - this is especially important for the flail hoses where they must be crossed, upper to lower, at the dipper and head pivots.

All Hydraulic Hoses (B.S.P.) now fitted to McConnel Power Arm Hedge/Grass Cutters have 'Soft Seal' connections on both flail and ram circuit hoses.

Recommended torque settings for nut security are as follows: -

1/4" BSP	=	24 N.m	or	18 lbf ft	REF.'O' ring
3/8" BSP	=	33 N.m	or	24 lbf ft	10 000 01
1/2" BSP	=	44 N.m	or	35 lbf ft	10 000 02
5/8" BSP	=	58 N.m	or	43 lbf ft	10 000 03
3/4" BSP	=	84 N.m	or	62 lbf ft	10 000 04
1" BSP	=	115 N.m	or	85 lbf ft	10 000 05
					10 000 06

For hose unions (B.S.P.) fitted in conjunction with bonded seals the recommended torque settings are as follows: -

1/4" BSP	=	34 N.m	or	25 lbf ft
3/8" BSP	=	75 N.m	or	55 lbf ft
1/2" BSP	=	102 N.m	or	75 lbf ft
5/8" BSP	=	122 N.m	or	90 lbf ft
3/4" BSP	=	183 N.m	or	135 lbf ft
1" BSP	=	203 N.m	or	150 lbf ft

SAFETY NOTE

Soft Seal hose connections are capable of holding pressure when the nut is only 'finger tight'. It is therefore recommended during dismantling that the hose be manually flexed to relieve any residual pressure with the retaining nut slackened prior to complete disassembly.

CONTROL CABLES

The cables operate on a push/pull system with the spool centring springs always returning the spool to the neutral position when the handle is released.

Care should be taken during installation and operation to ensure that the cables are not trapped or kinked. Any abrasion or damage to the outer casing should be sealed with plastic insulation tape to avoid moisture penetrating.

No routine adjustments of the cables are necessary, as they do not stretch. The threaded collar is correctly adjusted when the lever is in a vertical position in its housing allowing an equal amount of travel in both directions.

CAUTION

On no account should any attempt be made to lubricate the cables, which are assembled with a special lubricant during manufacture.

NOTE

Take care to ascertain the correct cable connections on both the control unit and the valve in the event of cable replacement.



McConnel Limited, Temeside Works, Ludlow, Shropshire SY8 1JL. England.
Telephone: 01584 873131. Facsimile: 01584 876463. www.mcconnel.com