

Publication 597
April 2009
Part No. 41571.97
Revision: 06.03.15

PA48 *Mk2*

TRACTOR MOUNTED HEDGE/GRASS CUTTER



Operator Manual

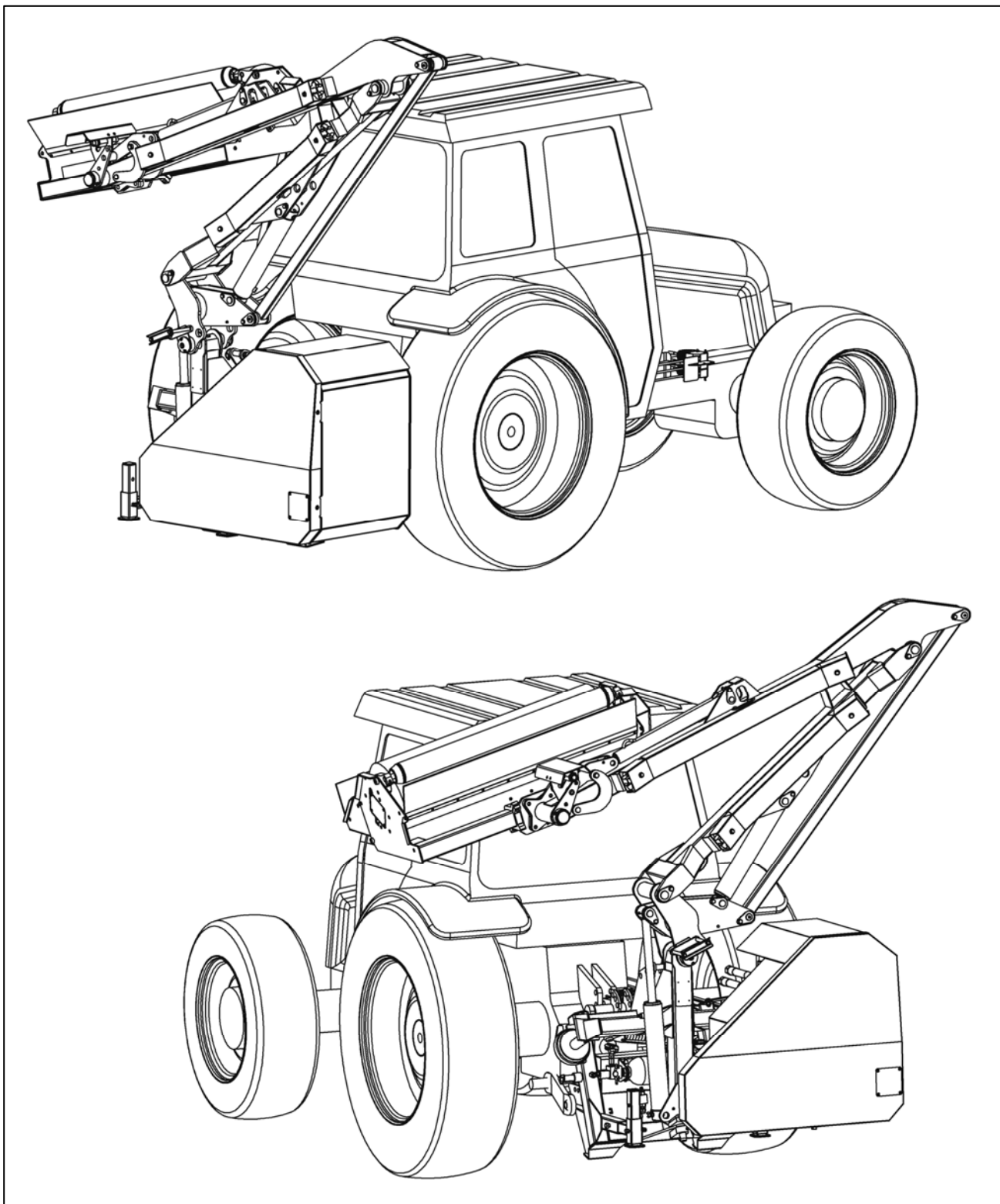

IMPORTANT

VERIFICATION OF WARRANTY REGISTRATION

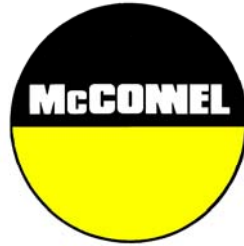

DEALER WARRANTY INFORMATION & REGISTRATION VERIFICATION

It is imperative that the selling dealer registers this machine with McConnel Limited before delivery to the end user – failure to do so may affect the validity of the machine warranty.

To register machines go to the McConnel Limited web site at www.mcconnel.com, log onto 'Dealer Inside' and select the 'Machine Registration button' which can be found in the Service Section of the site. Confirm to the customer that the machine has been registered in the section below.

Should you experience any problems registering a machine in this manner please contact the McConnel Service Department on 01584 875848.

Registration Verification

Dealer Name:
Dealer Address:
Customer Name:
Date of Warranty Registration:/...../..... Dealer Signature:

NOTE TO CUSTOMER / OWNER

Please ensure that the above section above has been completed and signed by the selling dealer to verify that your machine has been registered with McConnel Limited.

IMPORTANT: During the initial 'bedding in' period of a new machine it is the customer's responsibility to regularly inspect all nuts, bolts and hose connections for tightness and re-tighten if required. New hydraulic connections occasionally weep small amounts of oil as the seals and joints settle in – where this occurs it can be cured by re-tightening the connection – *refer to torque settings chart below*. The tasks stated above should be performed on an hourly basis during the first day of work and at least daily thereafter as part of the machines general maintenance procedure.

TORQUE SETTINGS FOR HYDRAULIC FITTINGS

HYDRAULIC HOSE ENDS		
BSP	Setting	Metric
1/4"	18 Nm	19 mm
3/8"	31 Nm	22 mm
1/2"	49 Nm	27 mm
5/8"	60 Nm	30 mm
3/4"	80 Nm	32 mm
1"	125 Nm	41 mm
1.1/4"	190 Nm	50 mm
1.1/2"	250 Nm	55 mm
2"	420 Nm	70 mm

PORT ADAPTORS WITH BONDED SEALS		
BSP	Setting	Metric
1/4"	34 Nm	19 mm
3/8"	47 Nm	22 mm
1/2"	102 Nm	27 mm
5/8"	122 Nm	30 mm
3/4"	149 Nm	32 mm
1"	203 Nm	41 mm
1.1/4"	305 Nm	50 mm
1.1/2"	305 Nm	55 mm
2"	400 Nm	70 mm

WARRANTY POLICY

WARRANTY REGISTRATION

All machines must be registered, by the selling dealer with McConnel Ltd, before delivery to the end user. On receipt of the goods it is the buyer's responsibility to check that the Verification of Warranty Registration in the Operator's Manual has been completed by the selling dealer.

1. LIMITED WARRANTIES

- 1.01. *All machines supplied by McConnel Ltd are warranted to be free from defects in material and workmanship from the date of sale to the original purchaser for a period of 12 months, unless a different period is specified.*
- 1.02. *All spare parts supplied by McConnel Ltd and purchased by the end user are warranted to be free from defects in material and workmanship from the date of sale to the original purchaser for a period of 6 months. All parts warranty claims must be supported by a copy of the failed part invoice to the end user. We cannot consider claims for which sales invoices are not available.*
- 1.03. *The warranty offered by McConnel Ltd is limited to the making good by repair or replacement for the purchaser any part or parts found, upon examination at its factory, to be defective under normal use and service due to defects in material or workmanship. Returned parts must be complete and unexamined. Pack the component(s) carefully so that any transit damage is avoided. All ports on hydraulic items should be drained of oil and securely plugged to prevent seepage and foreign body ingress. Certain other components, electrical items for example, may require particular care when packing to avoid damage in transit.*
- 1.04. *This warranty does not extend to any product from which McConnel Ltd's serial number plate has been removed or altered.*
- 1.05. *This warranty does not apply to any part of the goods, which has been subjected to improper or abnormal use, negligence, alteration, modification, fitment of non-genuine parts, accident damage, or damage resulting from contact with overhead power lines, damage caused by foreign objects (e.g. stones, iron, material other than vegetation), failure due to lack of maintenance, use of incorrect oil or lubricants, contamination of the oil, or which has served its normal life. This warranty does not apply to any expendable items such as blades, belts, clutch linings, filter elements, flails, flap kits, skids, soil engaging parts, shields, guards, wear pads, pneumatic tyres or tracks.*
- 1.06. *Temporary repairs and consequential loss - i.e. oil, downtime and associated parts are specifically excluded from the warranty.*
- 1.07. *Warranty on hoses is limited to 12 months and does not include hoses which have suffered external damage. Only complete hoses may be returned under warranty, any which have been cut or repaired will be rejected.*
- 1.08. *Machines must be repaired immediately a problem arises. Continued use of the machine after a problem has occurred can result in further component failures, for which McConnel Ltd cannot be held liable, and may have safety implications.*
- 1.09. *If in exceptional circumstances a non McConnel Ltd part is used to effect a repair, warranty reimbursement will be at no more than McConnel Ltd's standard dealer cost for the genuine part.*
- 1.10. *Except as provided herein, no employee, agent, dealer or other person is authorised to give any warranties of any nature on behalf of McConnel Ltd.*
- 1.11. *For machine warranty periods in excess of 12 months the following additional exclusions shall apply:*
 - 1.11.1. *Hoses, exposed pipes and hydraulic tank breathers.*
 - 1.11.2. *Filters.*
 - 1.11.3. *Rubber mountings.*
 - 1.11.4. *External electric wiring.*
 - 1.11.5. *Bearings and seals.*

- 1.12. All service work, particularly filter changes, must be carried out in accordance with the manufacturer's service schedule. Failure to comply will invalidate the warranty. In the event of a claim, proof of the service work being carried out may be required.
- 1.13. Repeat or additional repairs resulting from incorrect diagnosis or poor quality previous repair work are excluded from warranty.

NB Warranty cover will be invalid if any non-genuine parts have been fitted or used. Use of non-genuine parts may seriously affect the machine's performance and safety. McConnel Ltd cannot be held responsible for any failures or safety implications that arise due to the use of non-genuine parts.

2. REMEDIES AND PROCEDURES

- 2.01. The warranty is not effective unless the Selling Dealer registers the machine, via the McConnel Ltd web site and confirms the registration to the purchaser by completing the confirmation form in the operator's manual.
- 2.02. Any fault must be reported to an authorised McConnel Ltd dealer as soon as it occurs. Continued use of a machine, after a fault has occurred, can result in further component failure for which McConnel Ltd cannot be held liable.
- 2.03. Repairs should be undertaken within two days of the failure. Claims submitted for repairs undertaken more than 2 weeks after a failure has occurred, or 2 days after the parts were supplied will be rejected, unless the delay has been authorised by McConnel Ltd. Please note that failure by the customer to release the machine for repair will not be accepted as a reason for delay in repair or submitting warranty claims.
- 2.04. All claims must be submitted, by an authorised McConnel Ltd Service Dealer, within 30 days of the date of repair.
- 2.05. Following examination of the claim and parts, McConnel Ltd will pay, at their discretion, for any valid claim the invoiced cost of any parts supplied by McConnel Ltd and appropriate labour and mileage allowances if applicable.
- 2.06. The submission of a claim is not a guarantee of payment.
- 2.07. Any decision reached by McConnel Ltd is final.

3. LIMITATION OF LIABILITY

- 3.01. McConnel Ltd disclaims any express (except as set forth herein) and implied warranties with respect to the goods including, but not limited to, merchantability and fitness for a particular purpose.
- 3.02. McConnel Ltd makes no warranty as to the design, capability, capacity or suitability for use of the goods.
- 3.03. Except as provided herein, McConnel Ltd shall have no liability or responsibility to the purchaser or any other person or entity with respect to any liability, loss, or damage caused or alleged to be caused directly or indirectly by the goods including, but not limited to, any indirect, special, consequential, or incidental damages resulting from the use or operation of the goods or any breach of this warranty. Notwithstanding the above limitations and warranties, the manufacturer's liability hereunder for damages incurred by the purchaser or others shall not exceed the price of the goods.
- 3.04. No action arising out of any claimed breach of this warranty or transactions under this warranty may be brought more than one (1) year after the cause of the action has occurred.

4. MISCELLANEOUS

- 4.01. McConnel Ltd may waive compliance with any of the terms of this limited warranty, but no waiver of any terms shall be deemed to be a waiver of any other term.
- 4.02. If any provision of this limited warranty shall violate any applicable law and is held to be unenforceable, then the invalidity of such provision shall not invalidate any other provisions herein.
- 4.03. Applicable law may provide rights and benefits to the purchaser in addition to those provided herein.



DECLARATION OF CONFORMITY

Conforming to EU Machinery Directive 2006/42/EC

We,

McCONNEL LIMITED, Temeside Works, Ludlow, Shropshire SY8 1JL, UK

Hereby declare that:

The Product; *Tractor Mounted Hedgecutter / Grass Mower*

Product Code; *PA48*

Serial No. & Date Type

Manufactured in; *United Kingdom*

Complies with the required provisions of the Machinery Directive 2006/42/EC
The machinery directive is supported by the following harmonized standards;

- BS EN ISO 12100 (2010) Safety of machinery – General principles for design – Risk assessment and risk reduction.
- BS EN 349 (1993) + A1 (2008) Safety of machinery - Minimum distances to avoid the entrapment with human body parts.
- BS EN 953 (1997) + A1 (2009) Safety of machinery - Guards general requirements for the design and construction of fixed and movable guards.
- BS EN 4413 (2010) Hydraulic fluid power. Safety requirements for systems and their components.

McCONNEL LIMITED operates an ISO 9001:2008 quality management system, certificate number: FM25970.

This system is continually assessed by the;

British Standards Institution (BSI), Beech House, Milton Keynes, MK14 6ES, UK
BSI is accredited by UK Accreditation Service, accreditation number: UKAS 003.

The EC declaration only applies if the machine stated above is used in accordance with the operating instructions.

Signed *Responsible Person*

CHRISTIAN DAVIES on behalf of McCONNEL LIMITED

Status: *General Manager*

Date: *September 2015*

POWER ARM INSPECTION AND MAINTENANCE

A daily equipment inspection of the tractor and mower should be conducted before the equipment is used. You may use the inspection sheets to assist with these daily inspections. Any damaged or missing guards should be repaired or replaced before operating the mower. Failure to repair the damaged shield can result in objects being thrown from the mower and possibly hitting the operator or bystander.

Inspect the Mower for Safe Operating Condition

- Make sure the driveline guards and shielding are in place and in good repair.
- Inspect the flexible thrown object shielding to assure that they are in place on the front and rear of the mower head and in good repair. Repair or replace any damaged or missing thrown object shields.
- Ensure the mower cutting height is set high enough to reduce the possibility of the mower blades contacting the ground. Actual height will be dependent on the ground conditions. Increase the height when working in rough or undulating conditions.
- Inspect for broken, chipped, bent, missing, or severely worn blades. Replace damaged blades before operating the mower. Ensure the blade retaining bolts and fasteners are secure and tight.
- Ensure all head bolts and nuts are tight.
- Lubricate the driveline universal joints and telescoping members daily.
- Grease the rotor and roller bearings and inspect their condition.
- Inspect for any oil leaks or damaged hoses
- Inspect for worn or damaged decals and safety instructions. Replace unreadable, damaged or missing safety decals.
- Follow the operator's manual(s) inspection and maintenance instructions for lubricating parts, and keeping thrown object shielding, driveline guards, rotating parts shields, mower blades and decals in good repair.

Inspect the Tractor for Safe Operating Condition:

- Inspect the controls, lights, SMVs (Slow Moving Vehicle sign), seat belts, and ROPS to assure that they are in place and in good working order.
- Be sure the tires, wheels, lug bolts/nuts are in good condition.
- Make sure the tractor brakes and steering are in proper operating condition.
- Follow the operator's manual(s) inspection and maintenance procedures for keeping the tractor in good and safe condition before operating.

The inspection sheet on the following page should be kept in this book as a record. A second sheet is included for you to cut out and photocopy or the inspection sheets can be downloaded from our website at;

<http://www.mcconnel.com/support/aftersales/default.aspx?nav=After Sales>



POWER ARM PRE-OPERATION Inspection

Power Arm ID _____ Date: _____ Shift: _____

WARNING



Before conducting the inspection, make sure the tractor engine is off, the key removed, all rotation has stopped and the tractor is in park with the parking brake engaged. Make sure the mower head is resting on the ground or is securely blocked up and supported and all hydraulic pressure has been relieved.

Item	Condition at start of shift	Specific Comments if not O.K.
The Operator's Manual is in the Canister on the mower		
All Warning Decals are in place, clean and legible		
All Lights are clean and working		
The Mounting frame bolts are in place and tight		
The Arm pivot pins are tight and correctly secured		
There are no cracks in the arms		
The Hyd. Cylinder pins are tight and correctly secured		
The Hyd Cylinder hose connections are tight		
The Hyd. Pump hose connections are tight		
The Hyd. Valve hose connections are tight		
The Hyd. Valve controls function properly		
There are no damaged hoses		
The Oil level is to the green mark on the tank sight glass		
There is no evidence of Hydraulic oil leaks		
Flails are not missing, chipped, broken or excessively worn		
The Flail bolts are tight		
The Front & Rear Flaps are fitted and in good condition		
The Front hood is in place and in good condition		
The Wire Trap is in good condition		
The Skid shoes are in good condition & tight		
There are no cracks or holes in flail casing		
The Hyd. motor mounting bolts are tight		
All Flail Head Nuts and Bolts are tight		
The Rotor Bearings are in good condition and greased		
The Roller bearings are in good condition and greased		
The drive line Shaft guard is in good condition		
The drive line shaft guard is correctly secured		
Controls are securely mounted in the cab		
With engine running check arm operation		
Have a spare pack of flails, bushes, bolts and nuts		

Operators Signature: _____

DO NOT OPERATE an UNSAFE TRACTOR or MOWER



TRACTOR PRE-OPERATION Inspection

Power Arm ID _____ Date: _____ Shift: _____

WARNING



Before conducting the inspection, make sure the tractor engine is off, the key is removed all rotation has stopped and the tractor is in park with the parking brake engaged. Any implement attached to the tractor is firmly on the ground.

Item	Condition at start of shift	Specific Comments if not O.K.
The flashing lights function properly.		
All lights are clean and working correctly		
All cab windows are clean and wipers working correctly		
The SMV sign, where required, is clean and visible.		
The tyres are in good condition with correct pressure.		
The wheel nuts are tight.		
The tractor brakes are in good condition.		
The steering linkage is in good condition.		
There are no visible oil leaks.		
The hydraulic controls function properly.		
The ROPS or ROPS cab is in good condition.		
The seatbelt is in place and in good condition.		
The 3-point hitch is in good condition.		
The drawbar/pick up hook is secure & in good condition		
The PTO master shield is in place.		
The engine oil level is full.		
The brake fluid level is full.		
The power steering fluid level is full.		
The fuel level is adequate.		
The engine coolant fluid level is full.		
The radiator & oil cooler are free of debris.		
The air filter is in good condition		

Operators Signature: _____

DO NOT OPERATE an UNSAFE TRACTOR or MOWER



POWER ARM PRE-OPERATION Inspection

Power Arm ID _____ Date: _____ Shift: _____

WARNING



Before conducting the inspection, make sure the tractor engine is off, the key removed, all rotation has stopped and the tractor is in park with the parking brake engaged. Make sure the mower head is resting on the ground or is securely blocked up and supported and all hydraulic pressure has been relieved.

Item	Condition at start of shift	Specific Comments if not O.K.
The Operator's Manual is in the Canister on the mower		
All Warning Decals are in place, clean and legible		
All Lights are clean and working		
The Mounting frame bolts are in place and tight		
The Arm pivot pins are tight and correctly secured		
There are no cracks in the arms		
The Hyd. Cylinder pins are tight and correctly secured		
The Hyd Cylinder hose connections are tight		
The Hyd. Pump hose connections are tight		
The Hyd. Valve hose connections are tight		
The Hyd. Valve controls function properly		
There are no damaged hoses		
The Oil level is to the green mark on the tank sight glass		
There is no evidence of Hydraulic oil leaks		
Flails are not missing, chipped, broken or excessively worn		
The Flail bolts are tight		
The Front & Rear Flaps are fitted and in good condition		
The Front hood is in place and in good condition		
The Wire Trap is in good condition		
The Skid shoes are in good condition & tight		
There are no cracks or holes in flail casing		
The Hyd. motor mounting bolts are tight		
All Flail Head Nuts and Bolts are tight		
The Rotor Bearings are in good condition and greased		
The Roller bearings are in good condition and greased		
The drive line Shaft guard is in good condition		
The drive line shaft guard is correctly secured		
Controls are securely mounted in the cab		
With engine running check arm operation		
Have a spare pack of flails, bushes, bolts and nuts		

Operators Signature: _____

DO NOT OPERATE an UNSAFE TRACTOR or MOWER



TRACTOR PRE-OPERATION Inspection

Power Arm ID _____ Date: _____ Shift: _____

WARNING



Before conducting the inspection, make sure the tractor engine is off, the key is removed all rotation has stopped and the tractor is in park with the parking brake engaged. Any implement attached to the tractor is firmly on the ground.

Item	Condition at start of shift	Specific Comments if not O.K.
The flashing lights function properly.		
All lights are clean and working correctly		
All cab windows are clean and wipers working correctly		
The SMV sign, where required, is clean and visible.		
The tyres are in good condition with correct pressure.		
The wheel nuts are tight.		
The tractor brakes are in good condition.		
The steering linkage is in good condition.		
There are no visible oil leaks.		
The hydraulic controls function properly.		
The ROPS or ROPS cab is in good condition.		
The seatbelt is in place and in good condition.		
The 3-point hitch is in good condition.		
The drawbar/pick up hook is secure & in good condition		
The PTO master shield is in place.		
The engine oil level is full.		
The brake fluid level is full.		
The power steering fluid level is full.		
The fuel level is adequate.		
The engine coolant fluid level is full.		
The radiator & oil cooler are free of debris.		
The air filter is in good condition		

Operators Signature: _____

DO NOT OPERATE an UNSAFE TRACTOR or MOWER



For Safety and Performance ...

ALWAYS READ THIS BOOK FIRST

McCONEL LIMITED

**Temeside Works
Ludlow
Shropshire
England**

**Telephone: 01584 873131
www.mcconnel.com**

NOISE STATEMENT

The equivalent daily personal noise exposure from this machine measured at the operators' ear is within the range 78 – 85 dB, these figures apply to a normal distribution of use where the noise fluctuates between zero and maximum. The figures assume that the machine is fitted to a tractor with a 'quiet' cab with the windows closed in a generally open environment. We recommend that the windows are kept closed. With the cab rear window open the equivalent daily personal noise exposure will increase to a figure within the range 82 – 88 dB. At equivalent daily noise exposure levels of between 85 – 90 dB ear protection is recommended – it should be used if any window is left open.

CONTENTS

General Information	1
Introduction	2
Safety Information	4
Tractor Requirements	8
Tractor / Vehicle Preparation	9
Closed Centre Conversion Kit	10
Delivery & Pre-Attachment	11
Hydraulic Oil	12
Attachment to Tractor	13
Emergency Stopping	14
PTO Driveshaft Installation	16
Fitting Operator Control Units	17
Running Up Procedure	18
Removal from Tractor	19
Cable Controls	20
Cable Rotor Control	23
Electric Switchbox Controls	24
Electric Monolever Controls	28
XTC Proportional Controls	32
XTC Mk2 Proportional Controls	36
V4 Proportional Controls	40
Pre-Operational Checks	50
Transport	51
Operation	52
Breakaway System	54
Overhead Power Lines	56
Lift Float Kits	58
Angle Float	60
Valve Connections	61
Maintenance	62
Hydraulic System	65
Hydraulic Hoses	66
Control cables	67
PTO Shaft Lubrication	68
Torque Settings	69
Debris Blower Kit (<i>Optional Extra</i>)	70

GENERAL INFORMATION

Always read this manual before fitting or operating the machine – whenever any doubt exists contact your dealer or the McConnel Service Department for advice and assistance.

Use only McConnel Genuine Service Parts on McConnel Equipment and Machines

DEFINITIONS – *The following definitions apply throughout this manual:*

WARNING

An operating procedure, technique etc., which –
can result in personal injury or loss of life if not observed carefully.

CAUTION

An operating procedure, technique etc., which –
can result in damage to either machine or equipment if not observed carefully.

NOTE

An operating procedure, technique etc., which –
is considered essential to emphasis.

LEFT AND RIGHT HAND

This term is applicable to the machine when attached to the tractor and is viewed
from the rear – this also applies to tractor references.

MACHINE & DEALER INFORMATION

Record the Serial Number of your machine on this page and always quote this number when ordering parts. Whenever information concerning the machine is requested remember also to state the make and model of tractor to which the machine is fitted.

Machine Serial Number:

Installation Date:

Machine Model details:

Dealer Name:

Dealer Address:

Dealer Telephone No:

Dealer Email Address:

PA48 Series (All Models)

- Linkage mounted.
- Right or left hand cutting.
- 1.2M heavy duty flailhead (Hedge or Grass).
- Spring assisted gravity breakaway.
- Operator guard.
- 180 litre hydraulic reservoir.

PA48 SI Models

- Semi independent hydraulics
- Cable controls.
- Rotor engagement by tractor's PTO lever.
- 54HP hydraulic system.

PA48 TI Models

- Totally independent hydraulics powered by tandem PTO pump.
- Cable controls.
- Independent reversible rotor on/off valve.
- 54HP hydraulic system.

PA48E TI Models

- Totally independent hydraulics powered by tandem PTO pump.
- Electric controls - solenoid operated.
- Choice of control units - Switchbox, Monolever or Proportional
- Independent reversible rotor on/off valve.
- 54HP hydraulic system.



This machine has the potential to be extremely dangerous, in the wrong hands it can kill or maim. It is therefore imperative that both owner, and operator of this machine, read and understand the following section to ensure that they are fully aware of the dangers that do, or may exist, and their responsibilities surrounding the use and operation of the machine. The operator of this machine is responsible not only for their own safety but equally for the safety of others who may come into the close proximity of the machine, as the owner you are responsible for both.

When the machine is not in use the cutting head should be lowered to rest on the ground. In the event of a fault being detected with the machine's operation it should be stopped immediately and not used again until the fault has been corrected by a qualified technician.

POTENTIAL SIGNIFICANT DANGERS ASSOCIATED WITH THE USE OF THIS MACHINE:

- ▲ *Being hit by debris thrown by rotating components.*
- ▲ *Being hit by machine parts ejected through damage during use.*
- ▲ *Being caught on a rotating power take-off (PTO) shaft.*
- ▲ *Being caught in other moving parts i.e.: belts, pulleys and cutting heads.*
- ▲ *Electrocution from Overhead Power Lines (by contact with or 'flashover' from).*
- ▲ *Being hit by cutting heads or machine arms as they move.*
- ▲ *Becoming trapped between tractor and machine when hitching or unhitching.*
- ▲ *Tractor overbalancing when machine arm is extended.*
- ▲ *Injection of high-pressure oil from hydraulic hoses or couplings.*
- ▲ *Machine overbalancing when freestanding (out of use).*
- ▲ *Road traffic accidents due to collision or debris on the road.*

BEFORE USING THIS MACHINE YOU MUST:

- ▲ *Ensure you read all sections of the operator handbook.*
- ▲ *Ensure the operator is, or has been, properly trained to use the machine.*
- ▲ *Ensure the operator has been issued with and reads the operator handbook.*
- ▲ *Ensure the operator understands and follows the instructions in operator handbook.*
- ▲ *Ensure the tractor front, rear and side(s) are fitted with metal mesh or polycarbonate guards of suitable size and strength to protect the operator against thrown debris or parts.*
- ▲ *Ensure tractor guards are fitted correctly, are undamaged and kept properly maintained.*
- ▲ *Ensure that all machine guards are in position, are undamaged, and are kept maintained in accordance with the manufacturer's recommendations.*
- ▲ *Ensure flails and their fixings are of a type recommended by the manufacturer, are securely attached and that none are missing or damaged.*
- ▲ *Ensure hydraulic pipes are carefully and correctly routed to avoid damage by chaffing, stretching or pinching and that they are held in place with the correct fittings.*
- ▲ *Always follow the manufacturer's instructions for attachment and removal of the machine from the tractor.*
- ▲ *Check that the machine fittings and couplings are in good condition.*
- ▲ *Ensure the tractor meets the minimum weight recommendations of the machine's manufacturer and that ballast is used as necessary.*
- ▲ *Always inspect the work area thoroughly before starting to note obstacles and remove wire, bottles, cans and other debris.*
- ▲ *Use clear suitably sized warning signs to alert others to the nature of the machine working within that area. Signs should be placed at both ends of the work site. (It is recommended that signs used are of a size and type specified by the Department of Transport and positioned in accordance with their, and the Local Highways Authority, guidelines).*
- ▲ *Ensure the operator is protected from noise. Ear defenders should be worn and tractor cab doors and windows must be kept closed. Machine controls should be routed through proprietary openings in the cab to enable all windows to be shut fully.*
- ▲ *Always work at a safe speed taking account of the conditions i.e.: terrain, highway proximity and obstacles around and above the machine. Extra special attention should be applied to Overhead Power Lines. Some of our machines are capable of reach in excess of 8 metres (26 feet) this means they have the potential to well exceed, by possibly 3 metres (9' 9"), the lowest legal minimum height of 5.2 metres from the ground for 11,000 and 33,000 volt power lines. It cannot be stressed enough the dangers that surround this capability, it is therefore vital that the operator is fully aware of the maximum height and reach of the machine, and that they are fully conversant with all aspects regarding the safe minimum distances that apply when working with machines in close proximity to Power Lines. (Further information on this subject can be obtained from the Health & Safety Executive or your Local Power Company).*

- ▲ *Always disengage the machine, kill the tractor engine, remove and pocket the key before dismounting for any reason.*
- ▲ *Always clear up all debris left at the work area, it may cause hazard to others.*
- ▲ *Always ensure when you remove your machine from the tractor that it is left in a safe and stable position using the stands and props provided and secured if necessary.*

WHEN NOT TO USE THIS MACHINE:

- ▲ *Never attempt to use this machine if you have not been trained to do so.*
- ▲ *Never use a machine until you have read and understood the operator handbook, are familiar with it, and practiced the controls.*
- ▲ *Never use a machine that is poorly maintained.*
- ▲ *Never use a machine if guards are missing or damaged.*
- ▲ *Never use a machine on which the hydraulic system shows signs of wear or damage.*
- ▲ *Never fit, or use, a machine on a tractor that does not meet the manufacturer's minimum specification level.*
- ▲ *Never use a machine fitted to a tractor that does not have suitable front, rear and side(s) cab guarding made of metal mesh or polycarbonate.*
- ▲ *Never use the machine if the tractor cab guarding is damaged, deteriorating or badly fitted.*
- ▲ *Never turn a machine cutting head to an angle that causes debris to be ejected towards the cab.*
- ▲ *Never start or continue to work a machine if people are nearby or approaching - Stop and wait until they are at a safe distance before continuing. WARNING: Some Cutting Heads may continue to 'freewheel' for up to 40 seconds after being stopped.*
- ▲ *Never attempt to use a machine on materials in excess of its capability.*
- ▲ *Never use a machine to perform a task it has not been designed to do.*
- ▲ *Never operate the tractor or machine controls from any position other than from the driving seat, especially whilst hitching or unhitching the machine.*
- ▲ *Never carry out maintenance of a machine or a tractor whilst the engine is running – the engine should be switched off, the key removed and pocketed.*
- ▲ *Never leave a machine unattended in a raised position – it should be lowered to the ground in a safe position on a level firm site.*
- ▲ *Never leave a tractor with the key in or the engine running.*
- ▲ *Never carry out maintenance on any part or component of a machine that is raised unless that part or component has been properly substantially braced or supported.*
- ▲ *Never attempt to detect a hydraulic leak with your hand – use a piece of cardboard.*
- ▲ *Never allow children near to, or play on, a tractor or machine under any circumstances.*

ADDITIONAL SAFETY ADVICE

Training

Operators need to be competent and fully capable of operating this machine in a safe and efficient way prior to attempting to use it in any public place. We advise therefore that the prospective operator make use of relevant training courses available such as those run by the Agricultural Training Board, Agricultural Colleges, Dealers and McConnel.

Working in Public Places

When working in public places such as roadsides, consideration should be paid to others in the vicinity. Stop the machine immediately when pedestrians, cyclists and horse riders etc. pass. Restart only when they are at a distance that causes no risk to their safety.

Warning Signs

It is advisable that any working area be covered by suitable warning signs and statutory in public places. Signs should be highly visible and well placed in order to give clear advanced warning of the hazard. Contact the Department of Transport or your Local Highways Authority to obtain detailed information on this subject. The latter should be contacted prior to working on the public highway advising them of the time and location of the intended work asking what is required by way of signs and procedure. – ‘*Non-authorized placement of road signs may create offences under the Highways Act*’.

Suggested Warning Signs Required

“Road works ahead” warning sign with a supplementary **“Hedge cutting”** plate. **“For 1 mile”** or appropriate shorter distance may be added to the plate.

“Road narrows” warning sign with supplementary **“Single file traffic”** plate.

White on blue **“Keep right”** (*) arrow sign on rear of machine.

* Note – this applies to UK Market machines where traffic passes to the right of a machine working in the same direction as the traffic flow. The direction, use and colour of the arrow sign will depend on the country of use and the Local Highway Authorities regulations in the locality.

Use of Warning Signs

- On two-way roads one set of signs is needed facing traffic in each direction.
- Work should be within 1 mile of the signs.
- Work only when visibility is good and at times of low risk e.g.: NOT during ‘rush-hour’.
- Vehicles should have an amber-flashing beacon.
- Ideally, vehicles should be conspicuously coloured.
- Debris should be removed from the road and path as soon as practicable, and at regular intervals, wearing high visibility clothing and before removing the hazard warning signs.
- Collect all road signs promptly when the job is completed.

Although the information given here covers a wide range of safety subjects it is impossible to predict every eventuality that can occur under differing circumstances whilst operating this machine. No advice given here can replace ‘good common sense’ and ‘total awareness’ at all times but will go a long way towards the safe use of your McConnel machine.

TRACTOR REQUIREMENTS

Tractor Weight *(Including ballast weight if necessary)*

Minimum 3000kg

HP Requirement

Minimum 60HP

Tractor Linkage Requirement

Category 2

PTO Shaft

Tractor must be equipped with a live drive PTO to enable continuous flailhead operation when forward motion of the tractor is stopped.

Check Chains / Stabilizers

Check chains or stabilizers must be fitted and tightened.

Linkage Isolation

A linkage isolation facility is necessary for SI models only.

Tractor Relief Valve

For Si models only tractor relief valve must be set above 2000 psi (*140bar*).

Tractor Hydraulic Flow Rate

Hydraulic flow rates are not crucial for SI models

Front Mounted Models

Before fitting a front mounted machine to your tractor seek the advice of the tractor manufacturer or your local dealer regarding its suitability and all information in relation to additional linkage, ballast or weight requirements that may be required.

CAUTION



Never attach a machine to a tractor that is unsuitable or poorly maintained – where doubt exists always seek the advice of the tractor manufacturer or your local dealer before attempting to fit the machine.

VEHICLE / TRACTOR PREPARATION

We recommend vehicles are fitted with cabs using 'safety glass' windows and protective guarding when used with our machines.

Fit Operator Guard (Part No. 7313324) using the hooks provided. Shape the mesh to cover all vulnerable areas. The driver must be looking through mesh and/or polycarbonate glazing when viewing the flail head in any working position - unless the vehicle/ cab

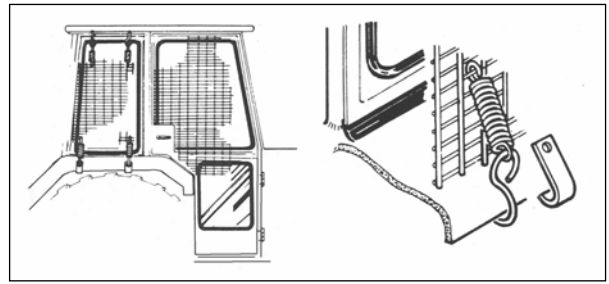

manufacturer can demonstrate that the penetration resistance is equivalent to, or higher than, that provided by mesh/polycarbonate glazing. If the tractor has a roll bar only, a frame must be made to carry both mesh and polycarbonate glazing. The operator should also use personal protective equipment to reduce the risk of serious injury such as; eye protection (mesh visor to EN1731 or safety glasses to EN166), hearing protection to EN352, safety helmet to EN297, gloves, filter mask and high visibility clothing.

Vehicle Ballast: It is imperative when attaching 'third-party' equipment to a vehicle that the maximum possible stability of the machine and vehicle combination is achieved – this can be accomplished by the utilization of 'ballast' in order to counter-balance the additional equipment added. **Front weights** may be required for rear mounted machines to place 15% of total outfit weight on the front axle for stable transport on the road and to reduce 'crabbing' due to the drag of the cutting unit when working on the ground.

Rear weights may be required to maintain a reasonable amount of rear axle load on the opposite wheel from the arms when in work; for normal off-ground work i.e. hedge cutting this should be 20% of rear axle weight or more for adequate control, and for ground work i.e. verge mowing with experienced operators, this can be reduced to 10%.

All factors must be addressed in order to match the type and nature of the equipment added to the circumstances under which it will be used – in the instance of Power Arm Hedgecutters it must be remembered that the machines centre of gravity during work will be constantly moving and will differ from that during transport mode, therefore balance becomes critical.

Factors that effect stability:

- *Centre of gravity of the tractor/machine combination.*
- *Geometric conditions, e.g. position of the cutting head and ballast.*
- *Weight, track width and wheelbase of the tractor.*
- *Acceleration, braking, turning and the relative position of the cutting head during these operations.*
- *Ground conditions, e.g. slope, grip, load capability of the soil/surface.*
- *Rigidity of implement mounting.*

Suggestions to increase stability:

- *Increasing rear wheel track; a vehicle with a wider wheel track is more stable.*
- *Ballasting the wheel; it is preferable to use external weights but liquid can be added to around 75% of the tyre volume – water with anti-freeze or the heavier Calcium Chloride alternative can be used.*
- *Addition of weights – care should be taken in selecting the location of the weights to ensure they are added to a position that offers the greatest advantage.*
- *Front axle locking (check with tractor manufacturer).*

NOTE: The advice above is offered as a guide for stability only and is not a guide to vehicle strength. It is recommended that you consult your vehicle manufacturer or local dealer to obtain specific advice on this subject, additionally advice should be sought from a tyre specialist with regard to tyre pressures and ratings suitable for the type and nature of the machine you intend to fit.

CLOSED CENTRE CONVERSION KIT – *Semi-Independent Models only*

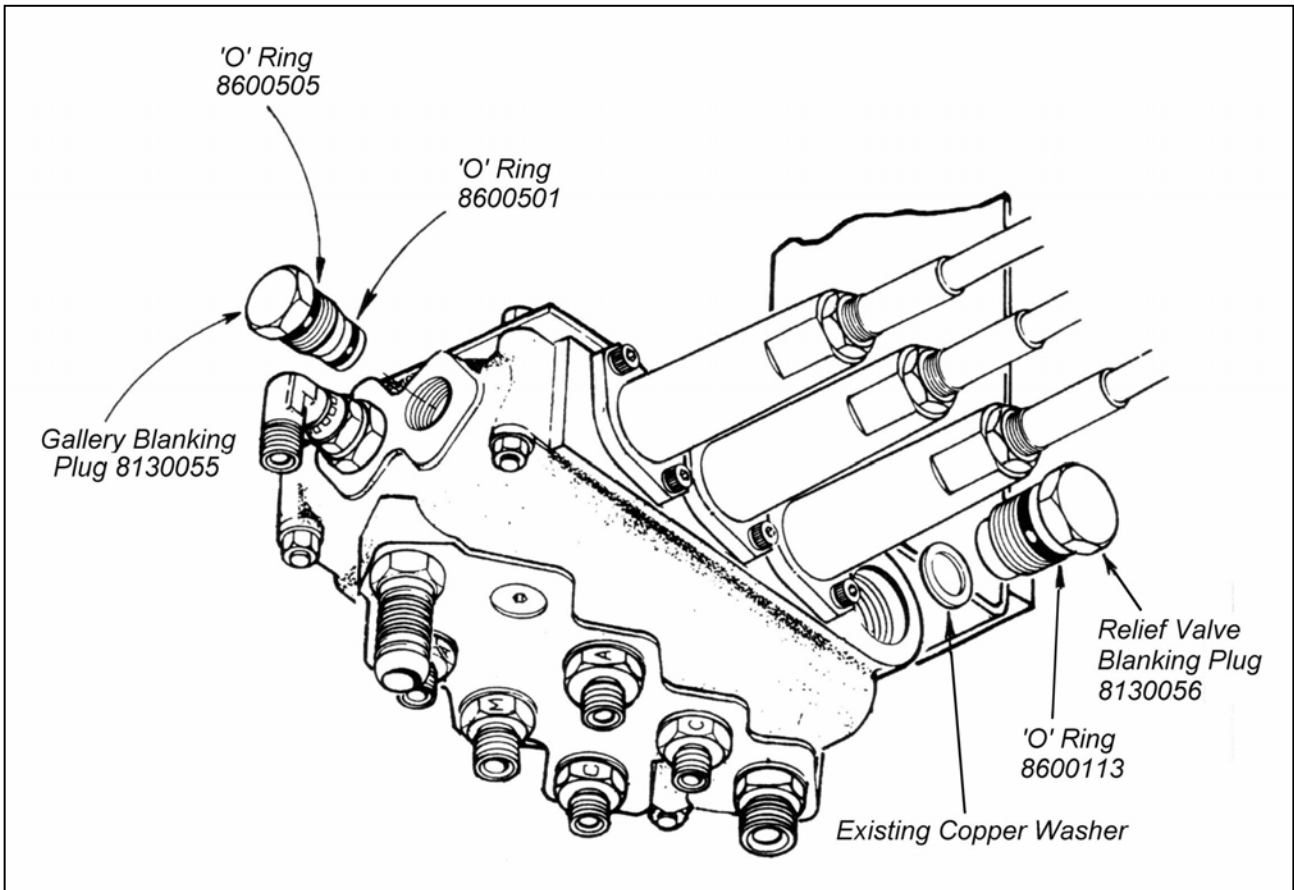

Control Valve Conversion Kit (Part No. 8130059)

This consists of a relief valve-blanking plug, which should be installed in place of the existing relief valve, and a pressure gallery blanking plug, which is installed in place of the standard blanking plug at the valve outlet end next to the lift ram gland connection.

NOTE: Take care when extracting the relief valve not to damage the copper sealing washer, as it is to be re-used.

When working in this mode the tractor's pressure control valve must not exceed 2500 P.S.I (170 Bar).

DELIVERY & PRE-ATTACHMENT (Dealer Reference)

Delivery

The machine will be delivered in a partially dismantled condition secured with transport straps and banding. Select a firm level site on which to place the machine before removing the straps, banding and other loose items.

Handling the Machine

Handling of the machine should always be performed using suitable overhead lifting equipment with a minimum safe lifting capacity over and above the maximum weight of the machine. Always ensure the machine is balanced during the lifting procedure and that all bystanders are kept well clear of the raised machine.

Post Delivery Assembly

In allow for a compact shipping state the machine will be delivered with the tension link disconnected from the rocker and the stand legs retracted – these items will need to be correctly installed before initial attachment to a tractor.

The procedure is as follows:

Stand Legs

Raise the machine using suitable overhead lifting equipment.

Lower stand legs and secure in position using pins and locking pins – the hole position selected should be at a height that places the gearbox stub axle approximately 75mm (3") below the height of the tractor's PTO shaft when the machine is at rest on the ground. Note the hole position used and ensure the equivalent one is used on both sides of the machine.

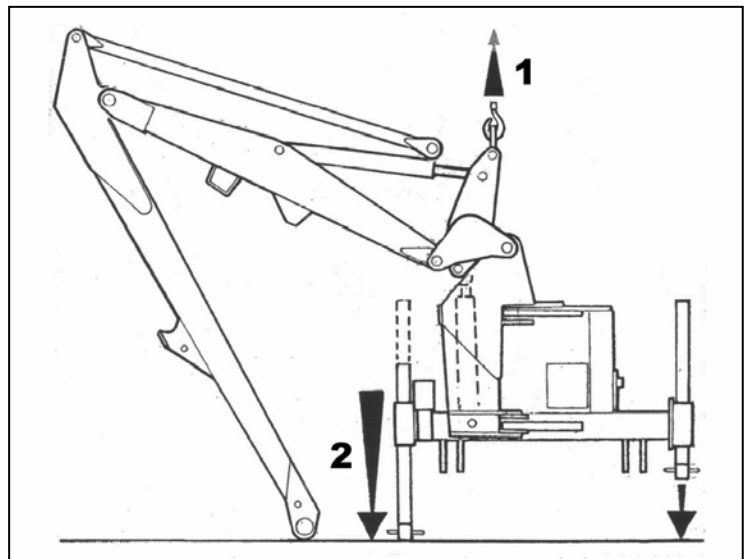

Tension Link Attachment

Request assistance for this task

- Operate 'lift up' on machine controls sufficient only for dipper arm to clear the ground.

Pivot out the dipper arm until the tension link can be connected and secure in position with pin and fixings supplied.

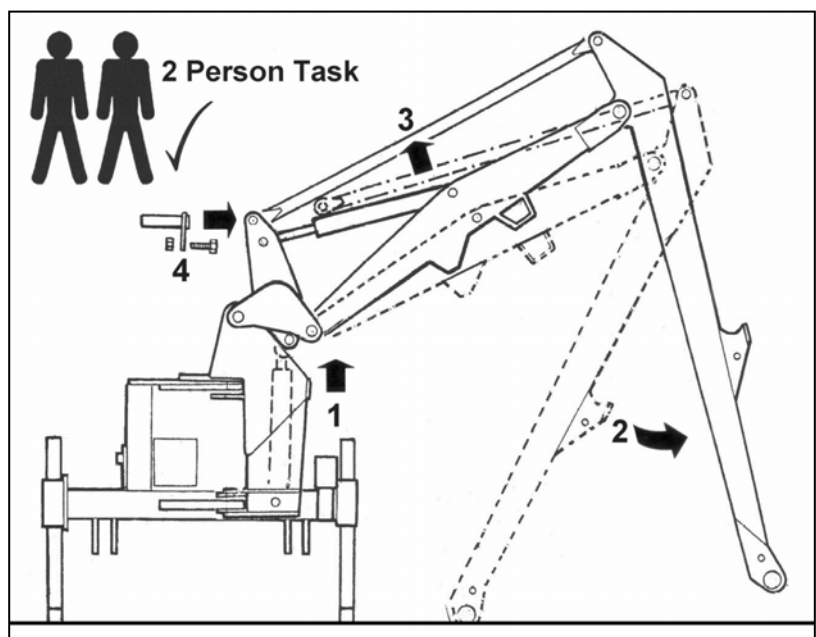

HYDRAULIC OIL

Hydraulic Oil Reservoir

Fill the tank with oil selected from the chart below or a good quality equivalent to a point where the level is between the minimum and maximum marks on the tank gauge. When the machine is initially run the level will drop as the oil is drawn into the circuit - *top back up as required to the correct level on the gauge.*

Always use clean receptacles when handling and transferring oil to avoid moisture or dirt contamination that can damage components and/or reduce machine performance.

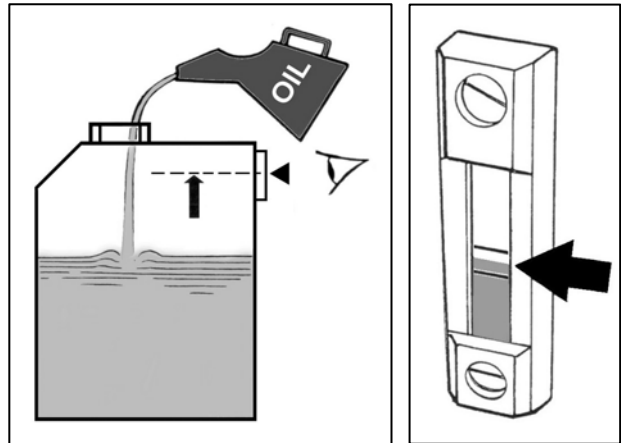

NOTE: Refer to the maintenance section for further information on the subject of hydraulic oil and system filtration.

Reservoir Capacity

The oil tank capacity of the machine is approximately **180 Litre**.

Recommended Hydraulic Oils

For initial filling of the oil reservoir, periodic oil changes and replenishment purposes the following hydraulic oils, or a good quality equivalent, are recommended;

NOTE: Only use oils that are ISO 18/16/13, NAS7, or cleaner.

Manufacturer	Cold or Temperate Climate	Hot Climate
BP	<i>Bartran 46</i> <i>Energol HLP-HM 46</i>	<i>Bartran 68</i> <i>Energol HLP-HM 68</i>
CASTROL	<i>Hyspin AWH-M 46</i>	<i>Hyspin AWH-M 68</i>
COMMA	<i>Hydraulic Oil LIC 15</i>	<i>Hydraulic Oil LIC 20</i>
ELF	<i>Hydrelf HV 46</i> <i>Hydrelf XV 46</i>	<i>Hydrelf HV 68</i>
ESSO	<i>Univis N 46</i>	<i>Univis N 68</i>
FUCHS (UK/Non UK markets*)	<i>Renolin 46</i> <i>Renolin HVZ 46</i> <i>Renolin CL46/B15*</i> <i>Renolin AF46/ZAF46B*</i>	<i>Renolin 68</i> <i>Renolin HVZ 68</i> <i>Renolin CL68/B20*</i> <i>Renolin AF68/ZAF68B*</i>
GREENWAY	<i>Excelpower HY 68</i>	<i>Excelpower HY 68</i>
MILLERS	<i>Millmax 46</i> <i>Millmax HV 46</i>	<i>Millmax 68</i> <i>Millmax HV 68</i>
MORRIS	<i>Liquimatic 5</i> <i>Liquimatic HV 46</i> <i>Triad 46</i>	<i>Liquimatic 6</i> <i>Liquimatic HV 68</i> <i>Triad 68</i>
SHELL	<i>Tellus 46</i> <i>Tellus T46</i>	<i>Tellus 68</i> <i>Tellus T68</i>
TEXACO	<i>Rando HD 46</i> <i>Rando HDZ 46</i>	<i>Rando HD 68</i> <i>Rando HDZ 68</i>
TOTAL	<i>Equivis ZS 46</i>	<i>Equivis ZS 68</i>

ATTACHMENT TO TRACTOR

Attachment of the machine to the tractor should always be performed on a firm level site.

* For **electric controlled models only** the base end pin of the angling ram and the rod end pins of the lift and reach rams must be removed.

* On **SI models only** reverse the tractor up as closely as possible. Fit suitable return connection to the tractor and connect the return hose before connecting the supply hose to the tractors external services point with a suitable self-seal coupling.

* **Ensure** that lift ram tap is fully open.

* With the aid of a crowbar prise the flail head sideways to allow the tractor to be reversed up

For **cable controlled models only** assistance will be needed to simultaneously select 'Reach Out' and 'Angle Down' to allow the oil to flow whilst the arms are being moved.

WARNING!

As a safety precaution to prevent the possibility of the flail head slipping sideways and the arm collapsing on the fitter as he is prying the head sideways, a loop of strong rope or wire, with sufficient slack to allow the required flail head movement should connect the frame and dipper - this will then act as an arrestor in the event of this happening. Leave in position until attachment is complete.

Adjust tractor drop arms to enable the draft links to lower to within 15" (375mm) of the ground.

Remove the top link and machine yoke completely.

Reverse the tractor squarely to the front of the machine, engage draft link pins and secure.

Attach yoke to the top hitch position on the tractor ensuring the lug for the top link is uppermost.

Unlimber the machine controls and fit into the tractor cab – *refer to control fitment pages..*

Install the top link between yoke and upper hitch position on the machine (*if necessary fitting Cat.1 sleeves into the ball ends of the top link*).

* Raise the machine on its three point linkage until the PTO shaft and the gearbox stub shaft are as near as possible in a straight line.

* At this point check that the welded in pins between the jaws of the yoke are tightly against the top of the mounting rail - If the welded in pins are not in contact with the rail the machine must be lowered to the ground, the next hole on the yoke top link lug selected, the machine raised again and contact checked. Repeat again in the third hole if necessary. *On subsequent fitment to the same tractor the hole selected is always used.*

Secure the yoke with the locking pins and spring cotters provided ensuring that they engage in matching holes in the mounting rails.

Lower the quadrant lever so that the machines weight is taken by the yoke - Adjust the top link to bring the pillar upright.

* Reposition the eccentric collars in the holes immediately behind the yoke and adjust until both collars abut against the face of the yoke plates. Tighten in position. *These collars act as stops for the yoke during subsequent fitting to the same tractor. If the tractor used is changed new collar positions will need to be worked out following the previous procedure.*

WARNING!

The quadrant lever or machine controls must be operated from the tractor seat. During this operation ensure no one is standing on or amongst the linkage arms or bars.

* Measure the PTO drive shaft length – refer to *PTO driveshaft installation* page for details.

Fit PTO shaft in position ensuring the collar locking devices on the shaft are fully engaged. Attach torque chains to convenient points to prevent the guards from rotating with the shaft.

Check that the rotor control valve is in the stop position (*TI models only*).

* For electric controlled machines only engage the PTO (*see page 18*) and select 'Lift down' until the lift ramrod together with its pin can be re-assembled in position. Similarly selecting 'Reach out' and 'Angle down' will enable the respective ram rods and pins to be replaced.

Carry out final adjustment of the tractor lift arm-leveling box to bring the main frame horizontal. This should be checked with the arms at approximately half reach with the flail head clear of the ground.

* Remove the rope arrestor loop.

Carry out final adjustment of the tractor lift arm-leveling box to bring the main frame horizontal. This should be checked with the arms at approximately half reach with the flail head clear of the ground.

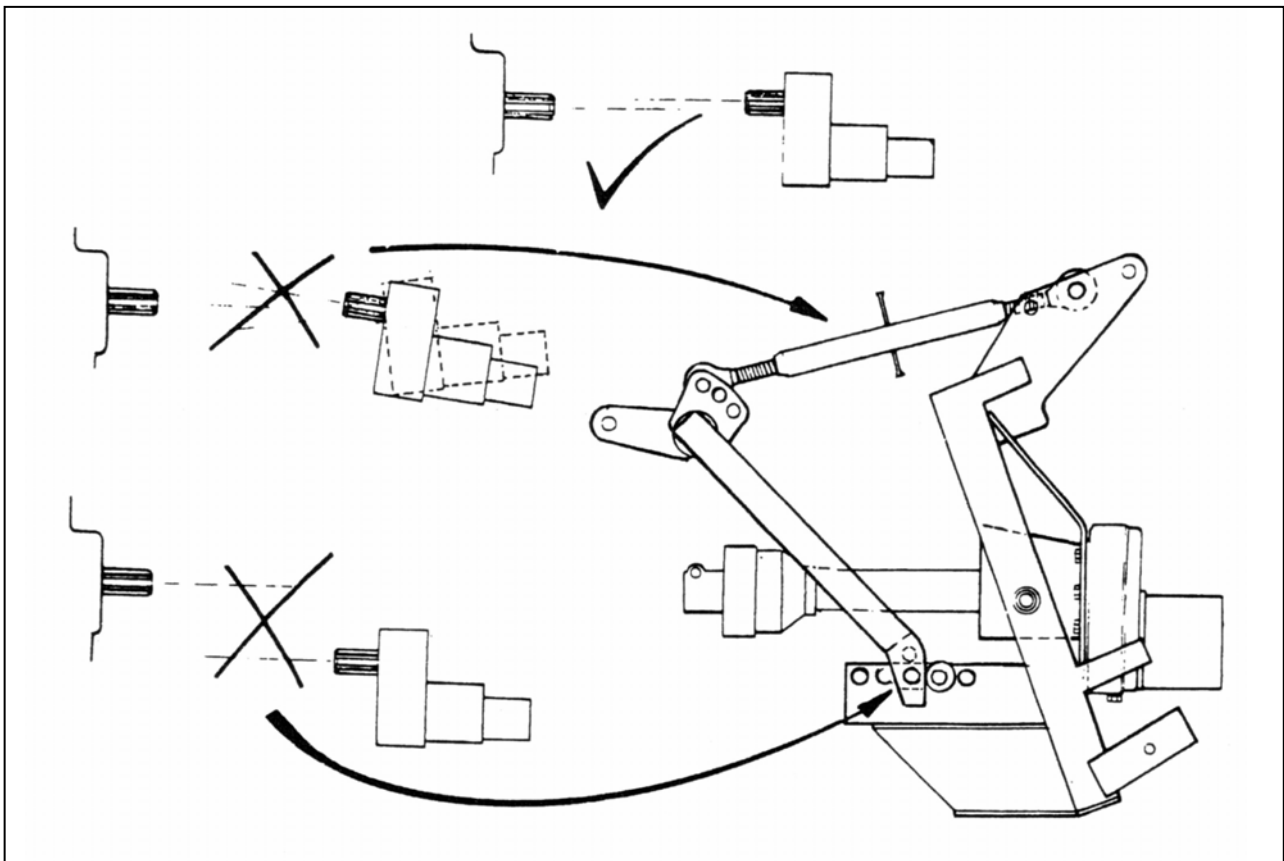

Raise the parking legs and secure in position.

Raise the parking legs and secure in position.

Carefully operate the machine through its full range of movement whilst checking that the hoses are not strained, pinched, chaffed or kinked and that all movements are functioning correctly.

* Assemble the cover plate and the hedge hood into position

Fold the machine into the transport position (*refer to page 48*).

The machine is now ready to proceed to the work site.

*The procedure stated above is for initial attachment of the machine only, for subsequent attachment of the machine to the same tractor paragraphs marked * no longer apply.*

EMERGENCY STOPPING

In all emergency situations machine operation and functions must be stopped immediately; **Stop PTO operation** using the tractor controls then immediately kill electrical power to the machine using the **Off (Emergency Stop)** switch on the machine's control unit.

WARNING: Auto-Reset Machines



When the Auto-Reset feature is active the machines arm set is capable of unintentional movement even when the PTO is switched off and stationary. Always ensure that electrical power to the machine is switched off using the **Off (Emergency Stop)** switch on the machine's control unit in emergency situations and/or when the machine is not being operated.

WARNING: Cable Operated Machines



In certain conditions, and/or if the Auto-Reset feature is active, the arm sets on cable operated machines possess the potential to move unintentionally, even when the PTO is switched off and stationary, if the levers were to be accidentally operated. Care must be adopted to avoid any movement of the levers when the machine is not being operated. Ensure arm sets are lowered fully to the ground when the machine is parked up or not in use.

PTO DRIVESHAFT INSTALLATION

The PTO driveshaft attaches between the tractor and the machine gearbox to transfer the power required to run and operate the machine – it is important to achieve the correct shaft length to avoid risk of it ‘bottoming out’ when raising or lowering the machine.

The procedure for measuring and cutting the shaft is as follows:

Measuring the PTO Shaft

With the machine attached to the tractor in the working position measure the horizontal distance ‘A’ from the tractor’s PTO to the input shaft on the machine’s gearbox and subtract 75mm (3”) – *this figure is the required shaft length.*

Place the fully closed PTO shaft on the ground and measure its overall length, if the shaft is shorter than the required length you can use it without the need to shorten - *providing it allows for a minimum 150mm (6”) overlap when fitted.*

If the shaft is longer subtract the required shaft length plus an additional 75mm (3”) - *the resulting figure is the excess length that will need to be removed from each half of the shaft.*

Cutting the PTO Shaft

Separate the two halves and using the measurement obtained above shorten both the plastic guarding and the inner steel profile tubes of each shaft by this same amount. De-burr the cut tubes with a file to remove rough or sharp edges and thoroughly clean to remove swarf before greasing, assembling and fitting the shaft.

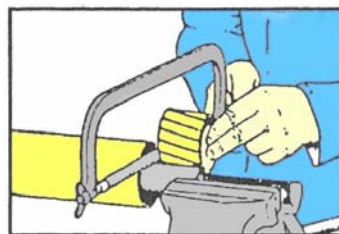
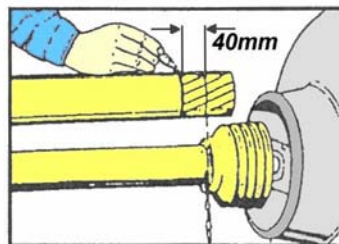
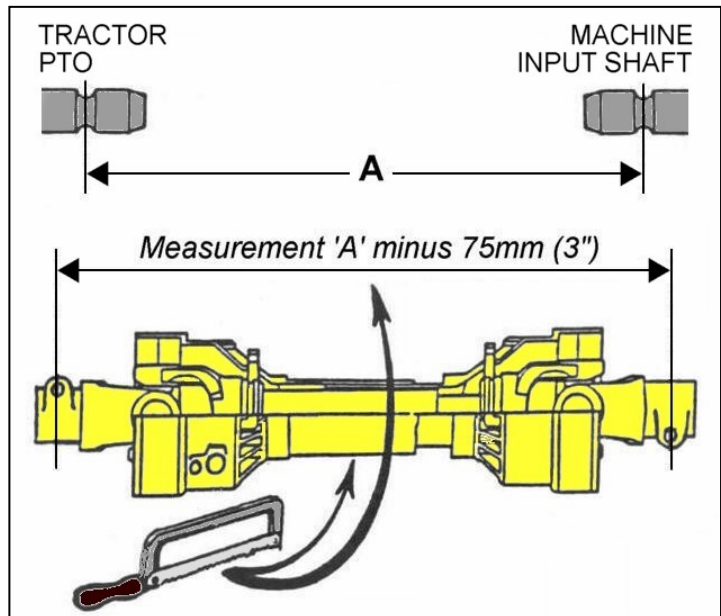

NOTE: For subsequent use with different tractors the shaft should be measured again to check suitability – *there must be a minimum shaft overlap of 150mm (6”).*

Maintenance

To increase the working life of the PTO shaft it should be periodically checked, cleaned and lubricated – *refer to the PTO maintenance section for further details on this subject.*

FITTING OPERATOR CONTROL UNITS

Fitment of the operator controls in the tractor cab will vary depending on the particular model or specification of machine – the information below lists the differing methods of fitment for the various types of controls available.

Cable Controls

Cable control units are provided with, and attached to, a mounting bracket – the bracket should be securely fixed to the internal mud wing or cab cladding in a suitable convenient location that offers ease of use without interfering with normal tractor operation.

In deciding the final position of the control unit bear in mind the location of the cable run – *make sure the minimum acceptable cable bend radii of 8" (200mm) is not exceeded.*

Ensure during fitting that no structural member of the tractor cab or roll bar is drilled or damaged.

The cable rotor control valve lever on cable controlled machines will be assembled as a component part of the main bank of controls and therefore shares the same mounting bracket.

On electric machines with cable operated rotor control valve the lever will be supplied as a 'standalone' unit with its own individual mounting bracket – this should be fitted in the same manner as above adopting the same precautions pertaining to attachment and cable runs.

Electric Controls

Depending on the particular type of control, electric units are supplied either with a mounting bracket or a mounting pillar which should be bolted to the internal mud wing or cab cladding in a suitable convenient location that offers ease of use without interfering with normal tractor operation. Mounting pillars can be bent or twisted to achieve a comfortable working position.

Ensure during fitting that no structural member of the tractor cab or roll bar is drilled or damaged.

The power supply cable should be connected directly to the tractors battery - do not use cigarette lighter type connections as these prove to be sporadic and unreliable for control applications. Control units are 12 volt D.C. operated; the brown lead is positive (+) and the blue lead is negative (-).

RUNNING UP PROCEDURE



CAUTION! Before initial use of a new machine, all lubrication points must be greased and the gearbox and oil tank levels checked and where required topped up before attempting to use the machine. See *maintenance section for details*.

TI Models only

Ensure that the rotor control valve is in the 'Stop' position, start tractor and engage PTO to allow oil to circulate through the return line filter for about 5 minutes without operation of the armhead control lever.

Operate the armhead levers through their complete range ensuring that all movements are functioning correctly.

Place the flail head at a safe attitude and move the rotor control to 'Start' position. After initial fluctuation the rotor should settle to a steady speed. Increase PTO speed to approximately 360rpm and run for a further five minutes before disengaging and stopping the tractor.

Check the hose runs and observe that they are free from any pinching, chafing straining or kinks. Re-check the oil level in the tank and top up if required.

SI Models only

Ensure PTO lever is in neutral position, and isolate tractor hydraulic linkage. Start tractor and select external service supply. Allow the tractor to run for several minutes before attempting to operate any of the machine control levers.

On operating move the levers through their complete range ensuring that all movements are functioning correctly.

Check the tractor rear axle oil level and top up if necessary.

Place the flail head at a safe attitude and bring tractor engine revolutions to 1000rpm, engage PTO and allow the rotor to run for several minutes. Do not leave the tractor cab or allow anyone to approach the flail head at this time.

CAUTION!

Do not allow the pump to continue working if the rotor does not turn – overheating and serious damage to the pump can occur in a very short time.

After running up the machine, increase PTO speed to approximately 360rpm and run for a further five minutes to allow the oil to circulate through the return line filter before disengaging the PTO and stopping the tractor.

Check the hose runs and observe that they are free from any pinching, chafing, straining or kinks. Re-check the oil level in the tank and top up as necessary.

All Models

Replace return filter elements after an initial 12 hours of operation and every 500 hours thereafter.

REMOVAL FROM TRACTOR

DANGER!
**READ CAREFULLY BEFORE COMMENCING TO REMOVE THE MACHINE
FROM THE TRACTOR**

**THE ORDER OF THE FOLLOWING STEPS MUST BE FOLLOWED EXACTLY
DISCONNECTING THE TOP LINK MUST BE THE LAST OPERATION PRIOR TO
DRIVING THE TRACTOR AWAY FROM THE MACHINE**

WARNING!

**Do not operate quadrant lever or machine controls through the rear cab window
whilst standing on or amongst linkage components - Always seek assistance.**

Select a firm level site for parking the machine.

Remove the parking feet, turn through 90° to face towards the ground and re-locate in the housing.

Unscrew the lift ram tap and with the machine at approximately half reach in normal working position, i.e. not broken back, operate the hydraulic service until the flail head roller is horizontal and level with the feet on the main frame.

Disengage tractor PTO and remove.

Disconnect stabiliser bars or loosen check chains as applicable.

Unbolt the control unit from the mounting pillar, remove from tractor cab and stow the levers or switchbox clear of the ground, On SI models only disconnect the supply and return hoses and stow with hose ends clear of the ground.

Raise the machine on the tractors linkage to take the weight off the yoke and remove the lower yoke pins.

Lower the tractor draft links and place machine firmly on the ground.

Remove draft links and the top link from the machine, drive tractor forward and remove yoke.

Blank off the end of the return hose with a plug or small plastic bag if a self seal coupling is not fitted.

Storage

If machine is to be left standing for an extended period of time, lightly coat the exposed portions of the ramrods with grease. Subsequently this grease should be wiped off before the rams are next moved.

If the machine has to be stored outside, tie a piece of tarpaulin or canvas over the control assembly, do not use a plastic bag as this can lead to rapid corrosion of the control unit.

CABLE CONTROLS

Cable controlled machines are supplied with a control unit of the type shown below – some versions will have the rotor control lever assembled alongside the armhead control levers as shown below and others may be supplied with the rotor control lever as a ‘standalone’ unit with its own individual mounting bracket.

The armhead control levers all move in a forwards and backwards direction each controlling a specific arm function.

Where applicable, if a machine is fitted with the optional electric lift float feature, operation of the lift float will be via an additional electrical switch which will need to be installed in a convenient location in the tractor cab.



LOCATION & FUNCTION OF CONTROLS

1. Arm Lift Control
2. Arm Reach Control
3. Head Angle Control / Angle Float Selection
4. Rotor Control

NOTE: The illustrations on the following pages show the methods of operation for all possible functions – depending on individual specifications some features may not be present on your particular machine and will therefore not be applicable.

ARM OPERATION

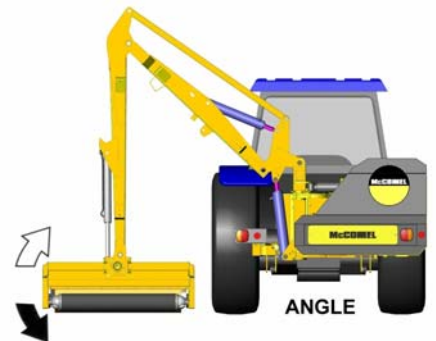
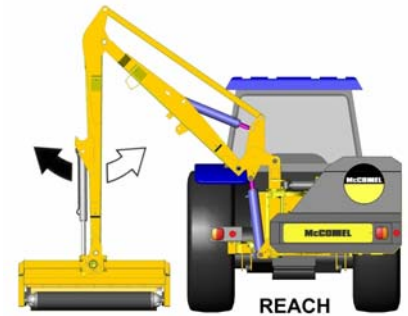
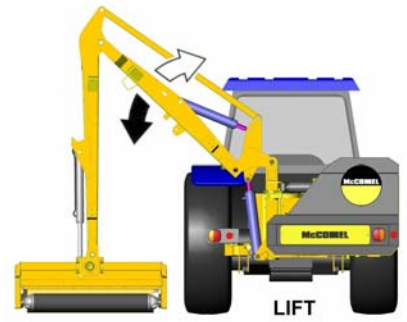

Rotor Control

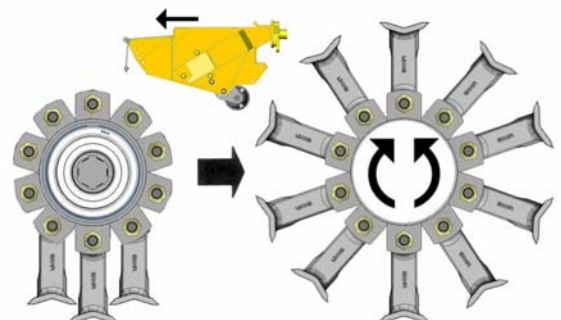

FLOAT OPERATION - Angle Float / Lift Float (where features are applicable)

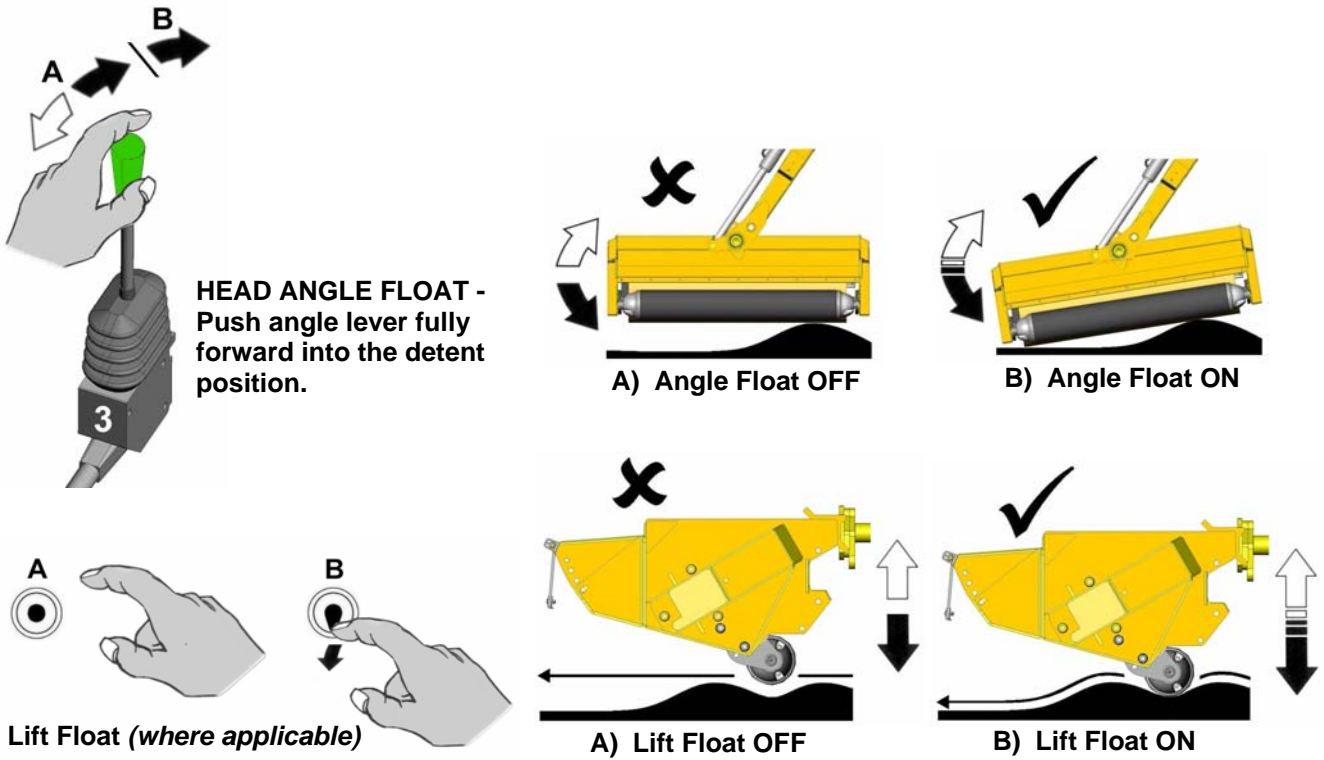

ROTOR CONTROL – SI Models only

On Semi-Independent machines rotor On/Off is controlled by operation of the tractors PTO lever.

Rotor Start

Bring tractor engine revs up to 1000rpm and engage PTO.

Rotor Stop

Disengage PTO.



WARNING!

Do not leave the tractor seat until the rotor has stopped completely.

CABLE ROTOR CONTROL

On cable rotor control machines the rotor is operated by the lever shown below – from the upright 'off' position pushing the lever forward switches the rotor on for downhill cutting and pulling the lever backwards switches the rotor on for uphill cutting. The small pivot locking lever mounted on the side of the control assembly rotates through 180° to lock the rotor in a specific cutting direction – this is a safety feature to avoid changes of rotor direction without first stopping the rotor. To change the direction of cut the rotor lever must be placed in the upright 'off' position; when the rotor has stopped rotating completely the pivot locking lever can be turned to the opposing position allowing the control lever to be operated for opposite cutting direction.

On some cable operated machines the rotor control lever will be assembled as part of the main bank of controls, whereas on others and all electric models it will be supplied as a 'standalone' unit with its own mounting bracket.

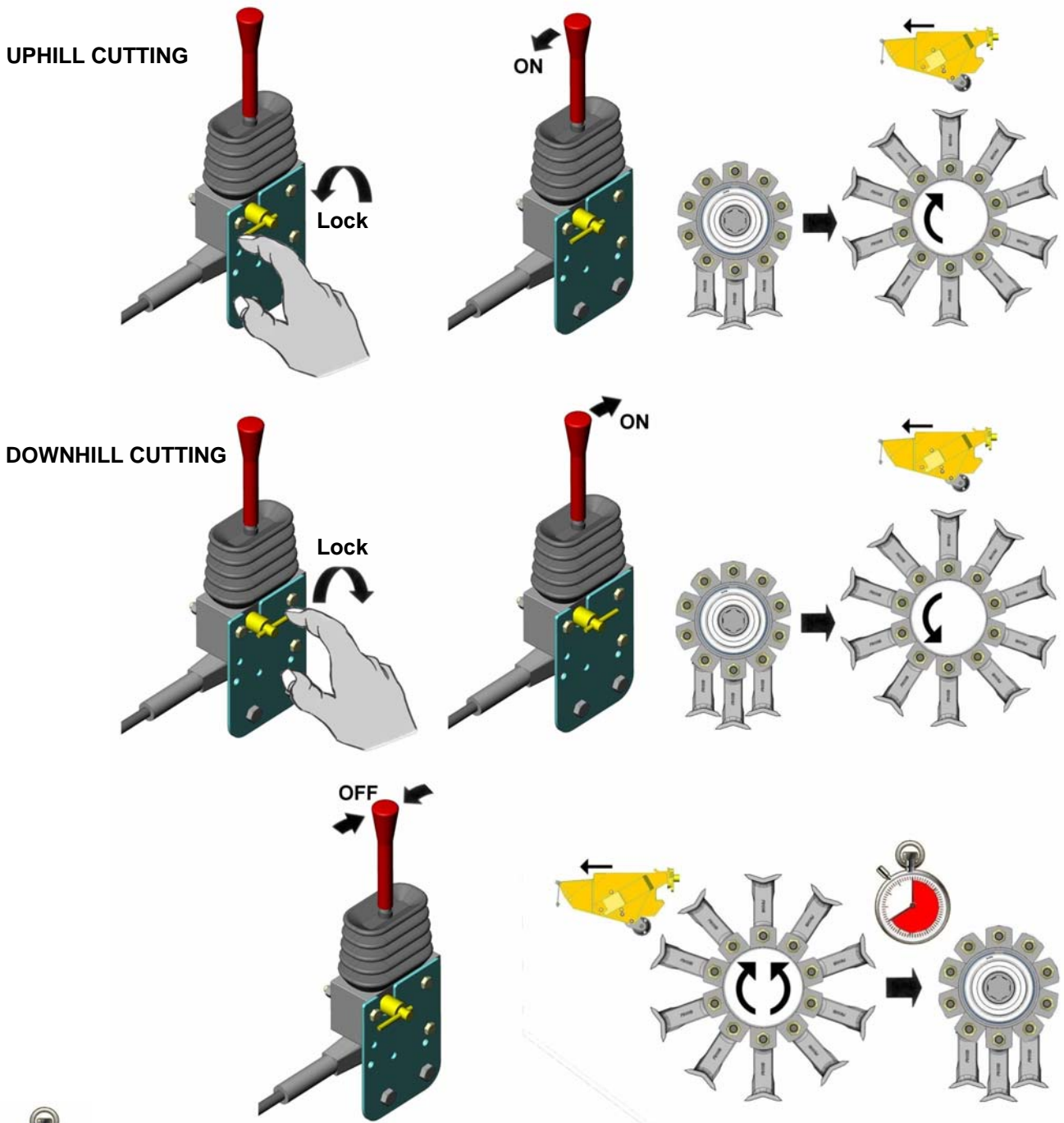

CAUTION: Ensure the rotor has stopped turning completely before attempting to change direction - When switched off a rotor can continue to 'freewheel' under its own momentum for up to 40 seconds before stopping.

ELECTRIC SWITCHBOX CONTROLS

Machines with Electric Switchbox Controls will be supplied with one of the control units shown below, the particular version will be dependent on the specification of the machine; machines fitted with cable rotor control will use the unit shown left whilst machines with electric rotor control will use the unit shown right – the only differences between the units is that the latter has 2 additional switches fitted for operation of the electric rotor control.

NOTE: On machines with 3 arm functions (Lift, Reach & Angle) levers 4 and 5 are not fitted and are replaced by blanking panels.



LOCATION & FUNCTION OF CONTROLS

- 1. Arm Lift Control
- 2. Arm Reach Control
- 3. Flailhead Angle Control
- 4. N/A
- 5. N/A

- A. Power On/Off
- B. N/A
- C. Head Float - Angle/Lift (Option)
- D. Rotor On/Off (Electric RCV models)
- E. Rotor Direction (Electric RCV models)

Powering the Controls

Activation of power to the control unit is by operation of switch 'A' as shown below:

Press the switch down for Power ON (LED light on)

Press the switch up for Power OFF (LED light off)

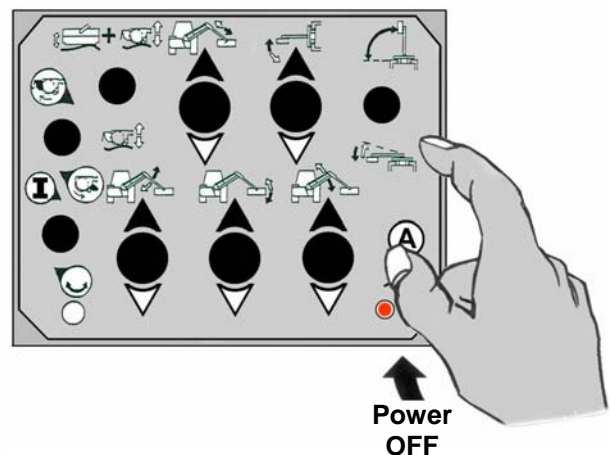
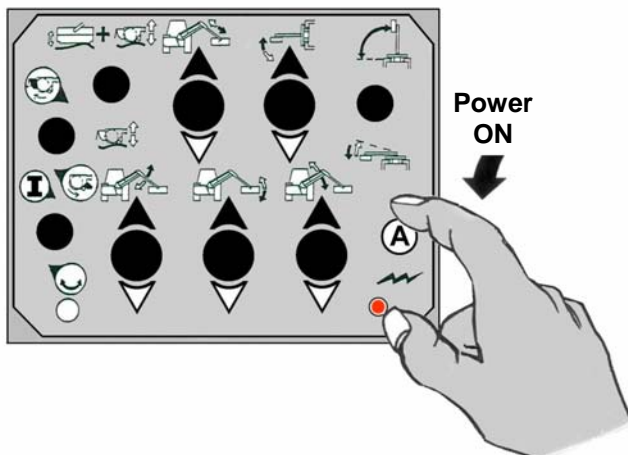

ARM OPERATION

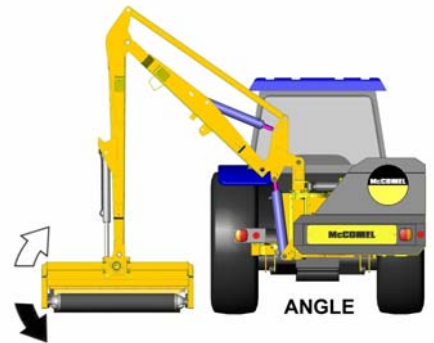
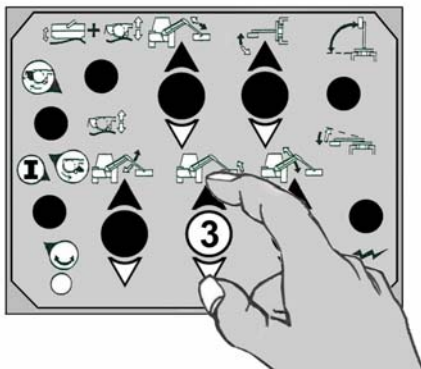
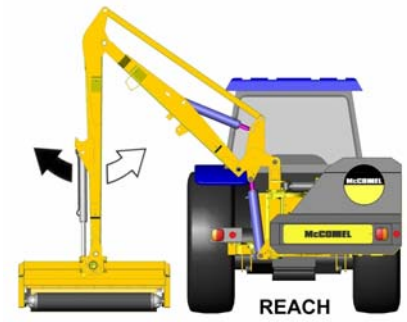
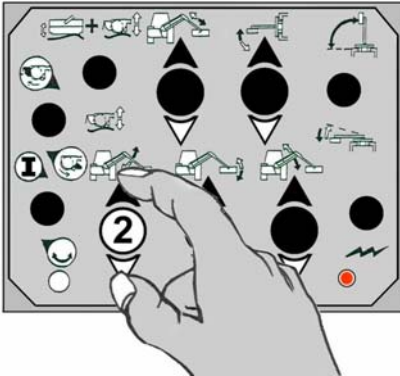
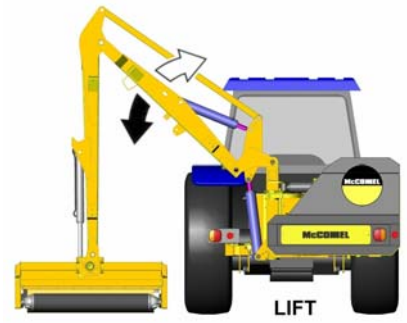
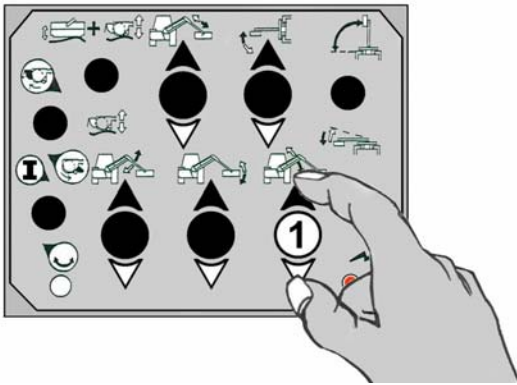

HEAD FLOAT OPERATION - Angle Float / Lift Float (where features are applicable)

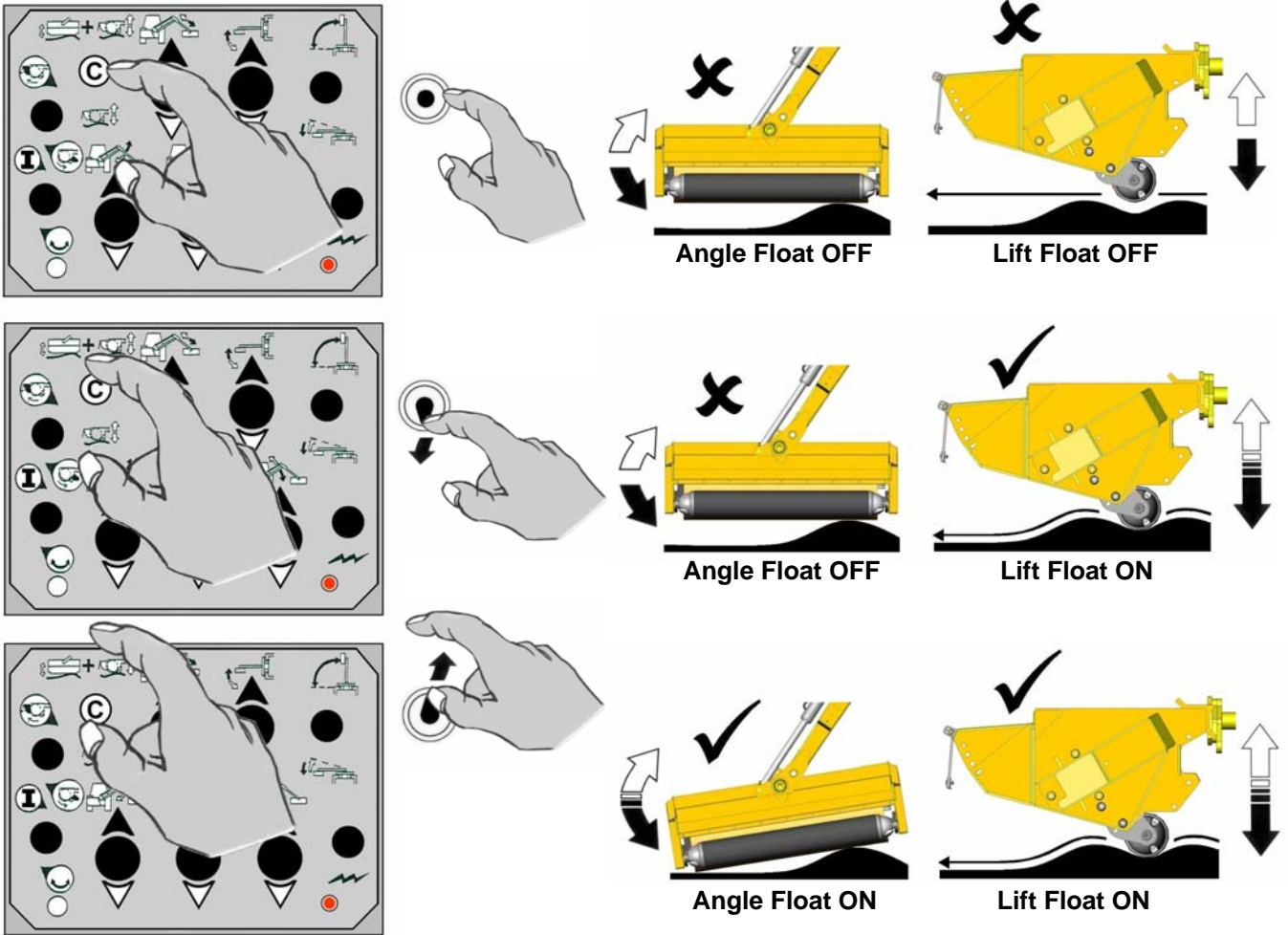

ROTOR OPERATION – Electric Rotor Control Models only

NOTE: The following section relates to machines with Electric Rotor Control only – for Cable Rotor Control models refer to the cable rotor control section.

Selection of Rotor Cutting Direction

Uphill Cutting



Downhill Cutting



Switching the Rotor On

For safety reasons, to prevent accidental starting of the rotor, the 'Rotor On' switch cannot be activated in a single operation or without first selecting the direction of cut – the procedure for starting the rotor is as follows:

Select the required cutting direction - the Rotor On/Off Switch (D) must then be switched upwards and held in position for a minimum of 8 seconds before switching it into the fully down 'on' position where it will remain until it is switched off. When the switch is moved to the down position the red LED light below the switch will be lit to signify the rotor is on – if the LED does not light the switch was not held in its up position for long enough and the rotor will not have started, repeat the process again holding the switch upwards for a longer period.

Rotor Start

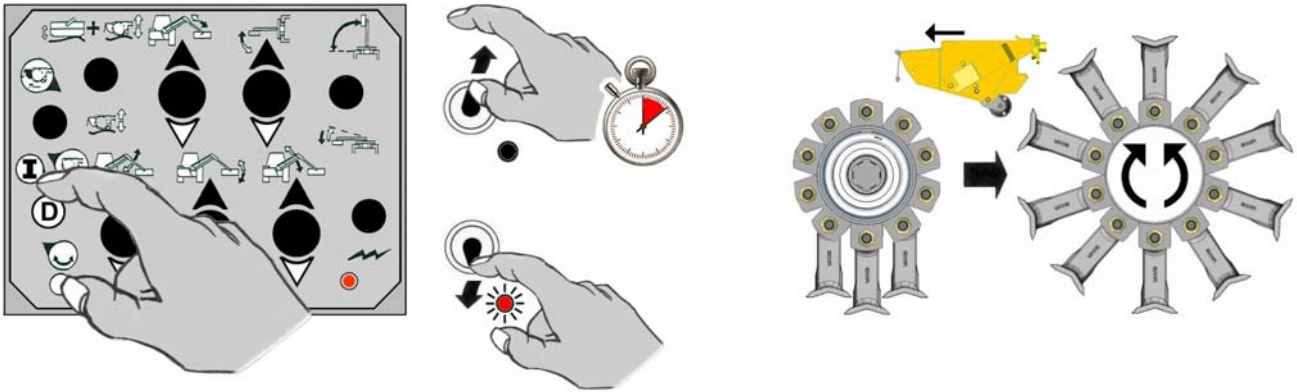

Switching the Rotor Off

Stopping the rotor is performed by switching either the Rotor Power Switch (D) or the Rotor Direction Switch (E) to the central (off) position – the red LED light will go out to signify the rotor has been switched off.



CAUTION: When the rotor is switched off it will continue to 'freewheel' under its own momentum for up to 40 seconds before finally coming to a standstill – do not leave the tractor cab or attempt to approach the flailhead until the rotor has stopped turning completely.

Rotor Stop

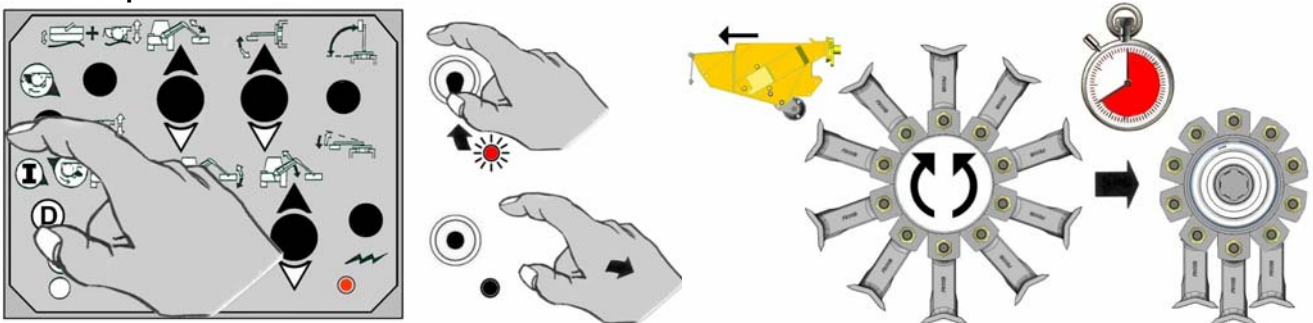

Alternative Rotor Stop

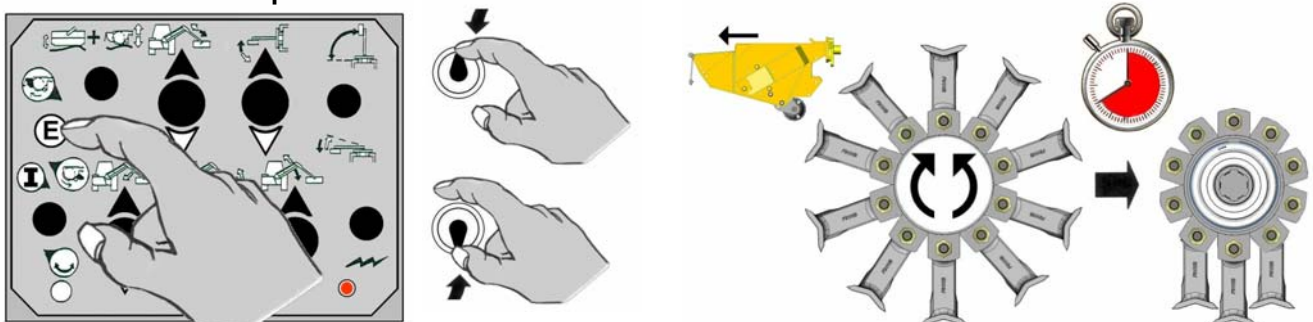

ELECTRIC MONOLEVER CONTROLS

Machines with Electric Monolever Controls will be supplied with one of the control units shown below, the particular version will be dependent on the specification of the machine; machines fitted with cable rotor control will use the unit shown left whilst machines with electric rotor control will use the unit shown right – the only differences between the units is that the latter has 2 additional switches fitted for operation of the electric rotor control.

NOTE: On machines with 3 arm functions (Lift, Reach & Angle) joystick buttons 4 & 5 do not operate any function.

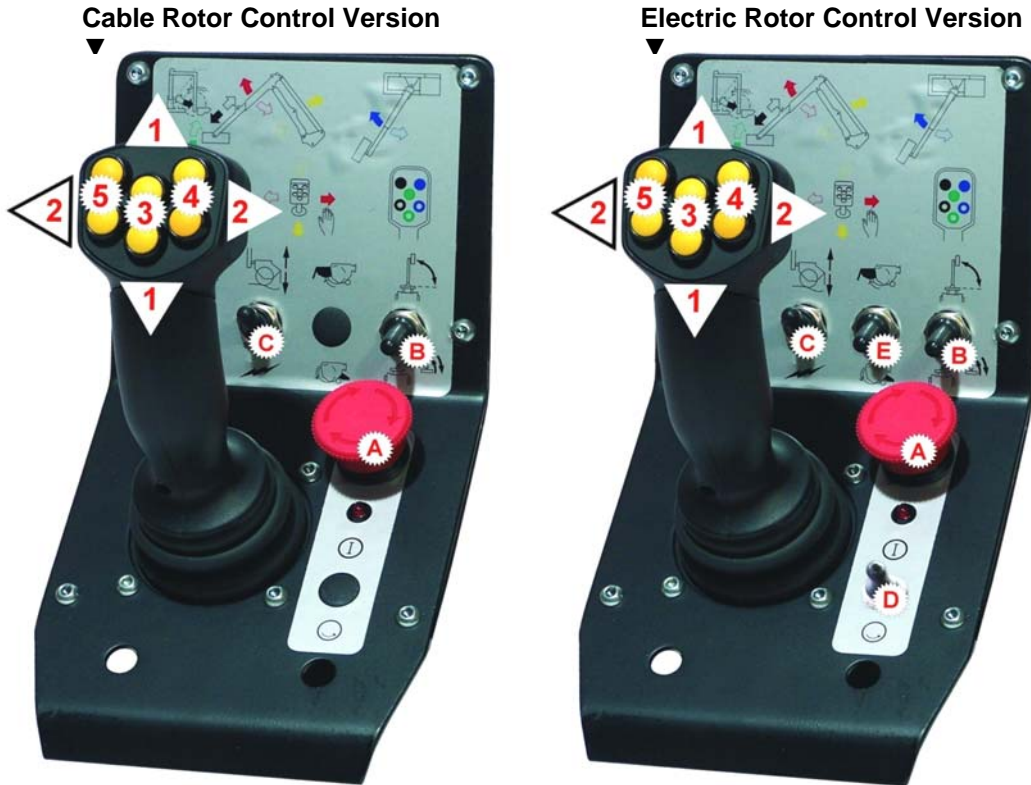

LOCATION & FUNCTION OF CONTROLS

1. Arm Lift Control
2. Arm Reach Control
3. Flailhead Angle Control
4. N/A
5. N/A

- A. Power On/Off (Emergency Stop)
- B. N/A
- C. Head Float - Angle/Lift (Option)
- D. Rotor On/Off (Electric RCV models)
- E. Rotor Direction (Electric RCV models)

Powering the Controls

Activation of power to the control unit is by operation of switch 'A' as shown below:

Rotate the switch clockwise to Power ON (LED light on)

Press the switch to Power OFF or Emergency Stop (LED light off)



ARM OPERATION

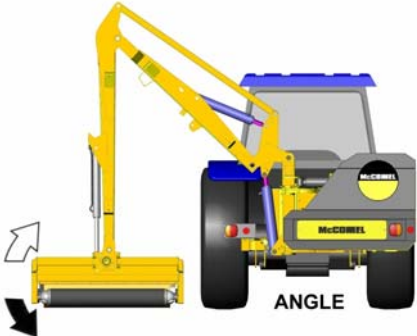
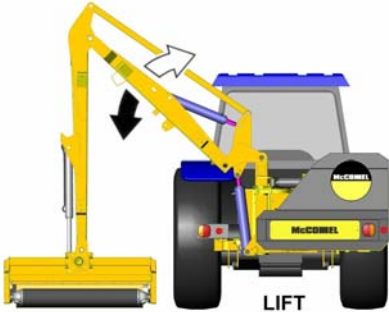

HEAD FLOAT OPERATION - Angle Float / Lift Float (where features are applicable)

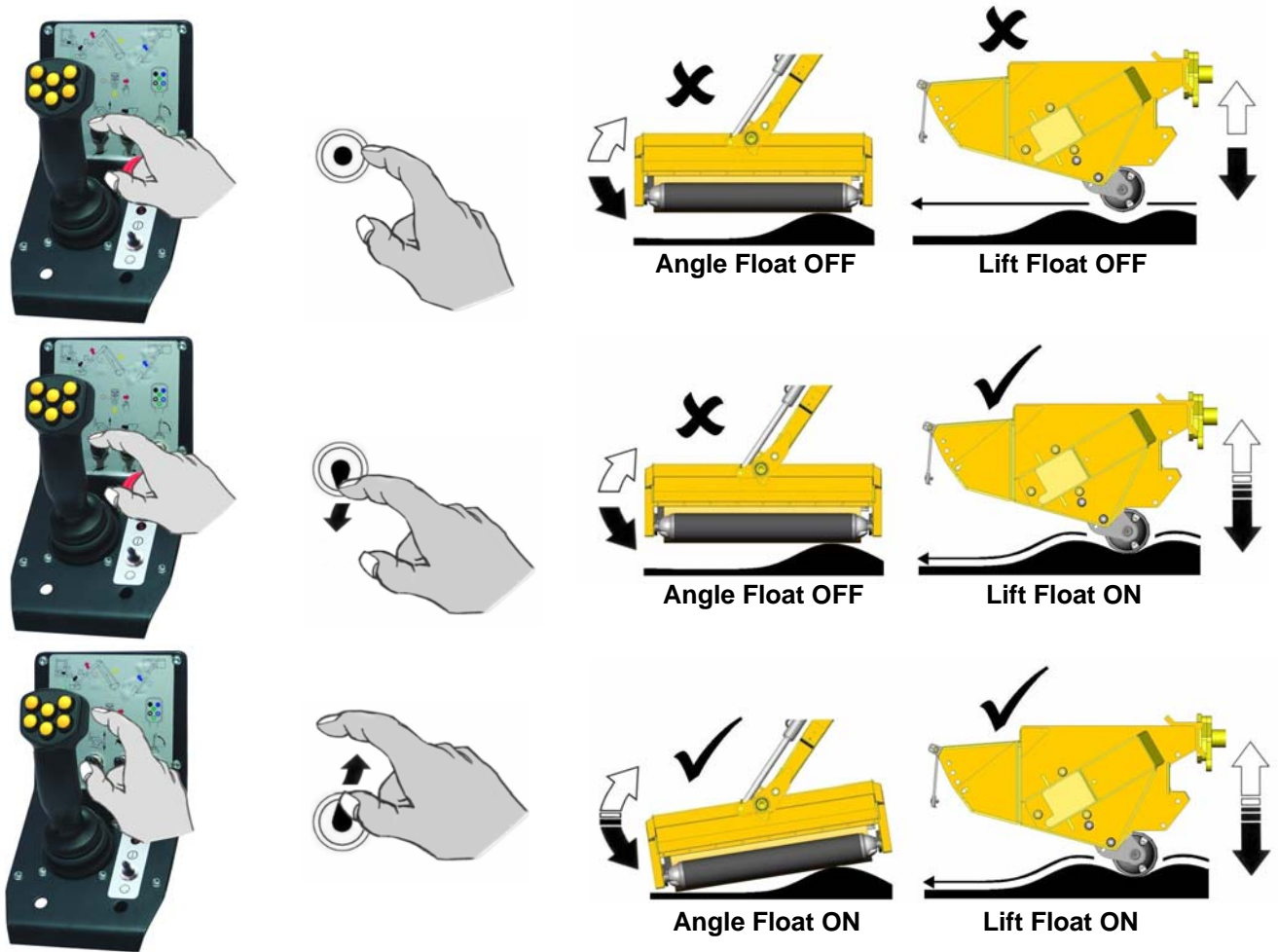

ROTOR OPERATION – Electric Rotor Control Models only

NOTE: The following section relates to machines with Electric Rotor Control only – for Cable Rotor Control models refer to the cable rotor control section.

Selection of Rotor Cutting Direction

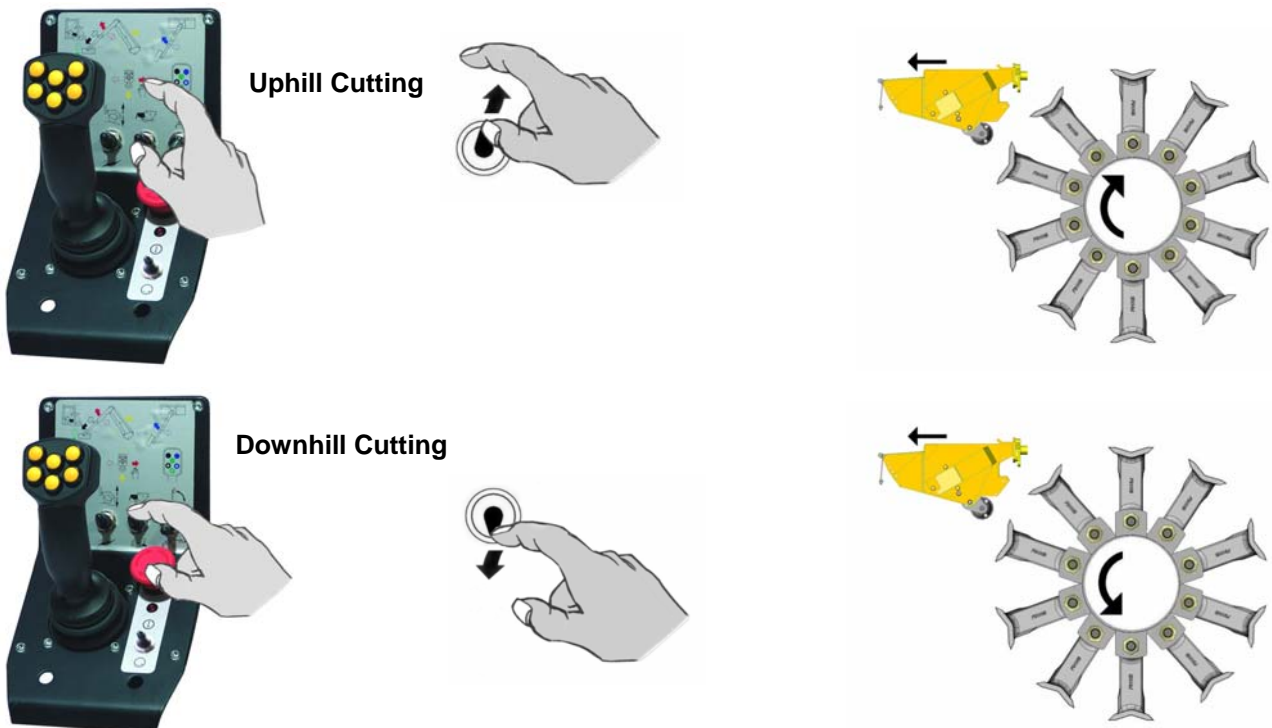

Switching the Rotor On

For safety reasons, to prevent accidental starting of the rotor, the 'Rotor On' switch cannot be activated in a single operation or without first selecting the direction of cut – the procedure for starting the rotor is as follows:

Select the required cutting direction - the Rotor On/Off Switch (D) must then be switched upwards and held in position for a minimum of 8 seconds before switching it into the fully down 'on' position where it will remain until it is switched off. When the switch is moved to the down position the red LED light above the switch will be lit to signify the rotor is on – if the LED does not light the switch was not held in its up position for long enough and the rotor will not have started, repeat the process again holding the switch upwards for a longer period.

Rotor Start

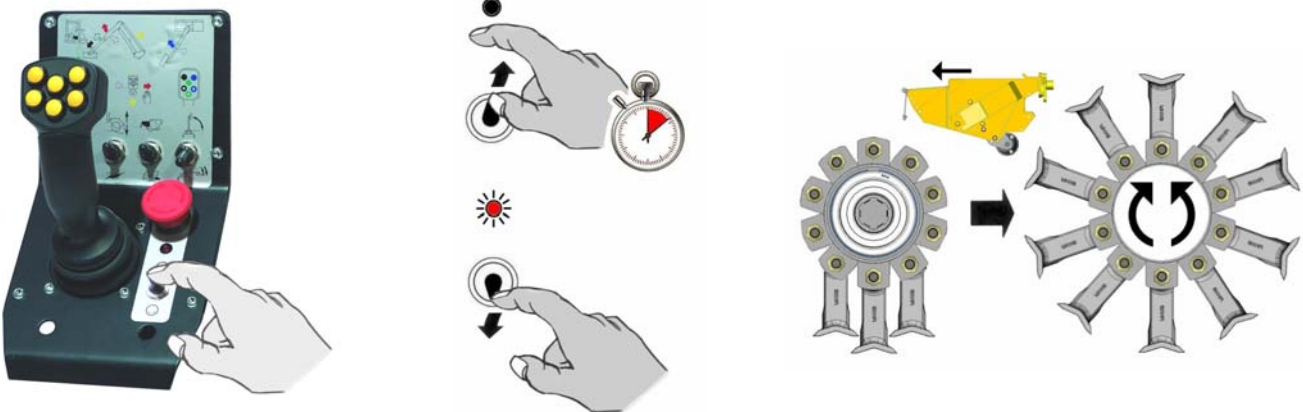

Switching the Rotor Off

Stopping the rotor is performed by switching either the Rotor Power Switch (D) or the Rotor Direction Switch (E) to the central (off) position – the red LED light will go out to signify the rotor has been switched off.



CAUTION: When the rotor is switched off it will continue to 'freewheel' under its own momentum for up to 40 seconds before finally coming to a standstill – do not leave the tractor cab or attempt to approach the flailhead until the rotor has stopped turning completely.

Rotor Stop

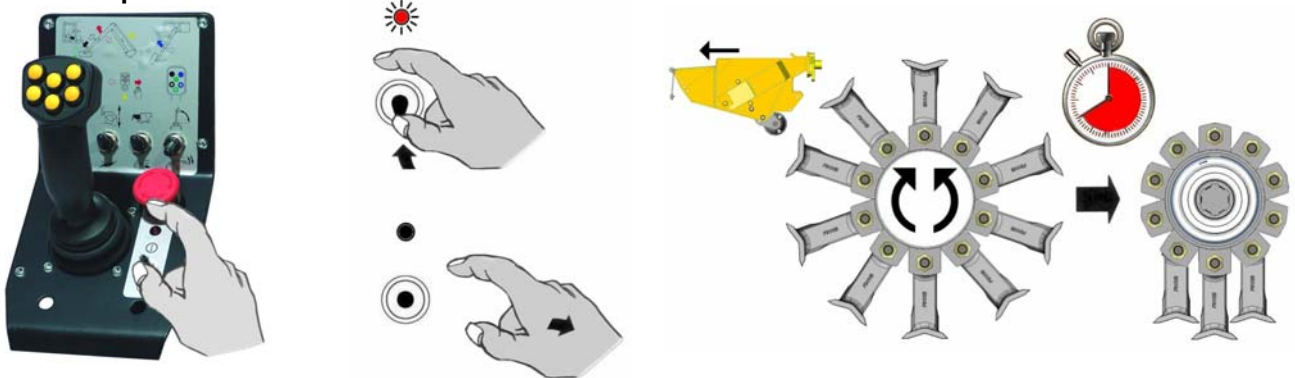

Alternative Rotor Stop

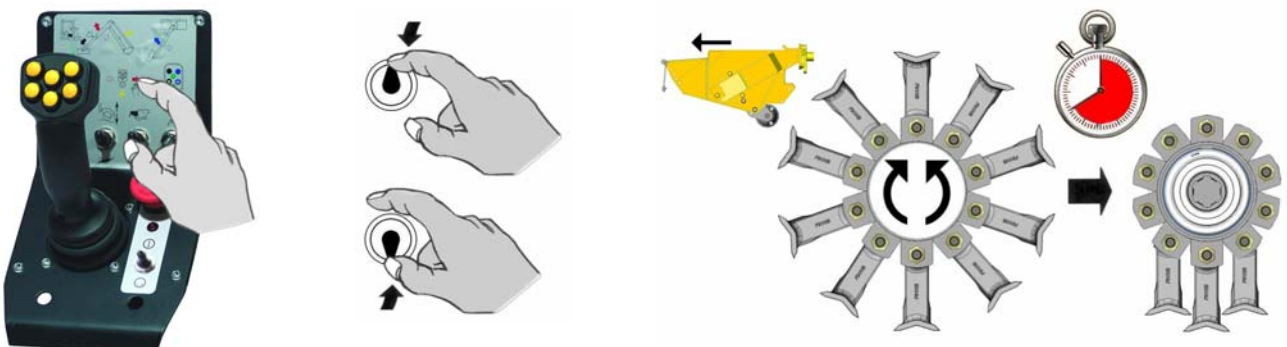

XTC PROPORTIONAL SWITCHBOX CONTROLS

Machines with XTC Proportional Controls will be supplied with the control unit shown below. The units for both electric and cable rotor machines are identical except that on cable versions the rotor control switches (D & E shown below) will not provide a function as rotor operation will be controlled by a separate cable lever unit (refer to specific cable rotor control page for operation information).

NOTE: On machines with 3 arm functions (Lift, Reach & Angle) levers 4 & 5 where fitted will not operate any functions.



LOCATION & FUNCTION OF CONTROLS

- | | |
|----------------------------|--|
| 1. Arm Lift Control | A. Power On/Off |
| 2. Arm Reach Control | B. N/A |
| 3. Flailhead Angle Control | C. Head Float - Angle/Lift (Option) |
| 4. N/A | D. Rotor On/Off (Electric RCV models) |
| 5. N/A | E. Rotor Direction (Electric RCV models) |

Powering the Controls

Activation of power to the control unit is by operation of switch 'A' as shown below:

Press the switch down for Power ON (LED light on)

Press the switch up for Power OFF (LED light off)



ARM OPERATION

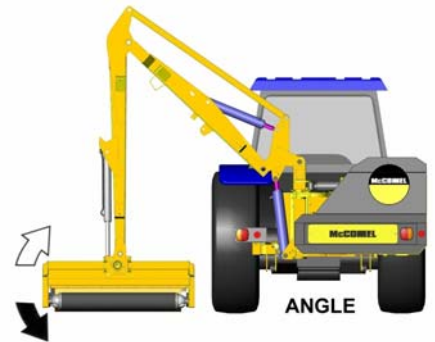
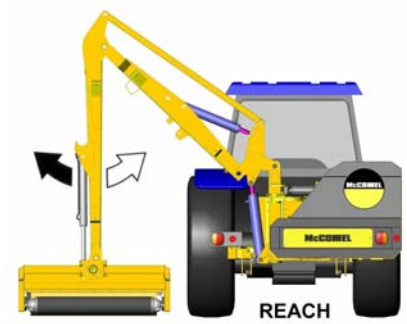
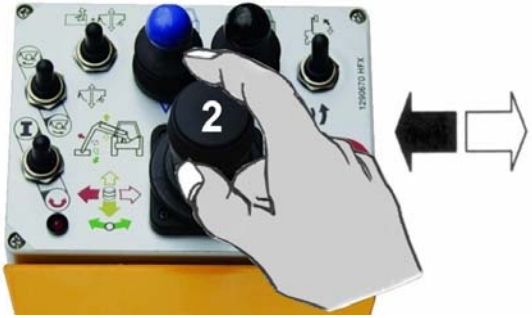
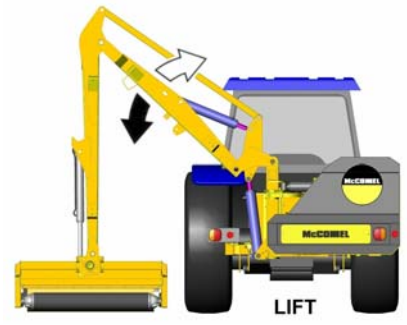

HEAD FLOAT OPERATION - Angle Float / Lift Float (where features are applicable)

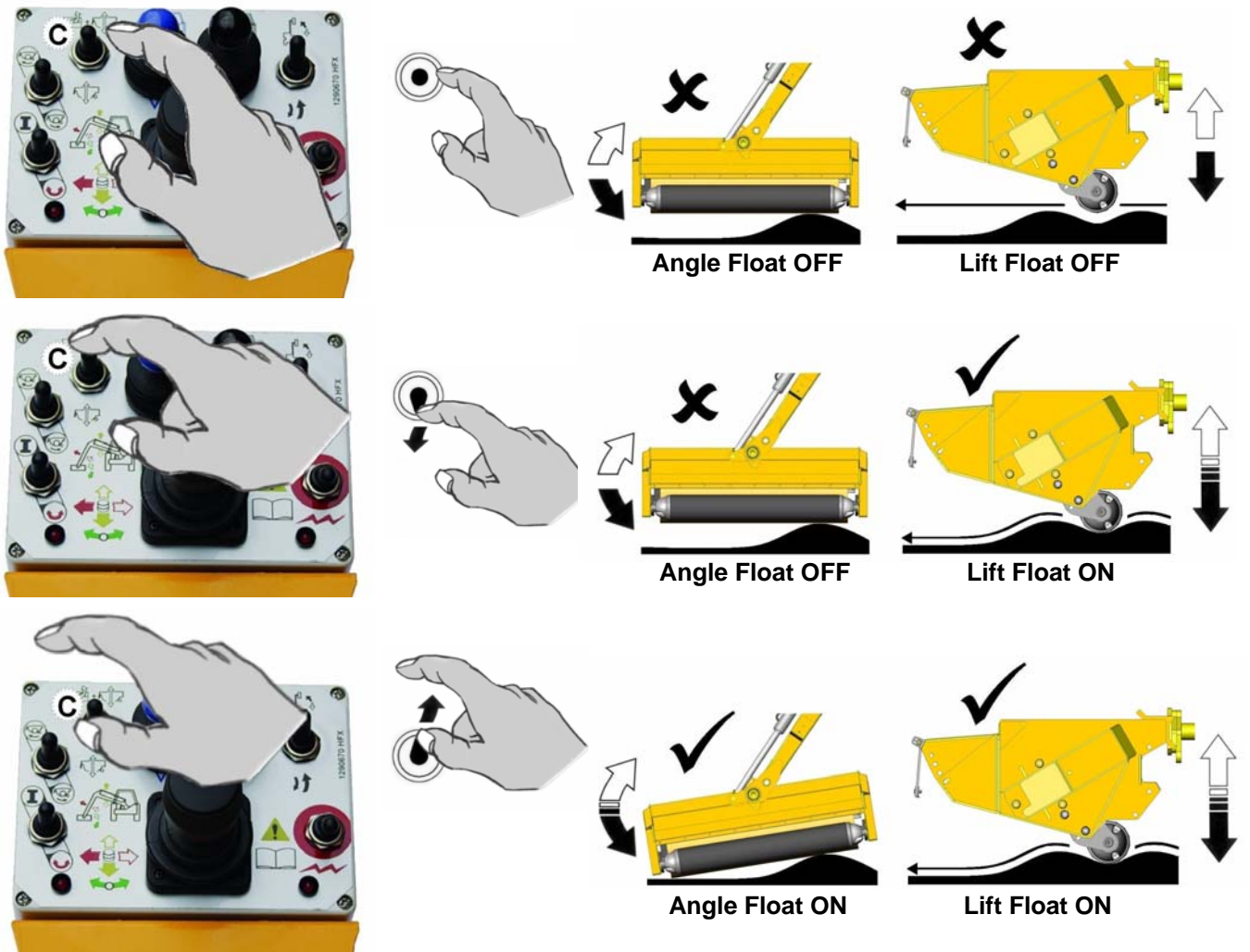

ROTOR OPERATION – Electric Rotor Control Models only

NOTE: The following section relates to machines with Electric Rotor Control only – for Cable Rotor Control models refer to the cable rotor control section.

Selection of Rotor Cutting Direction

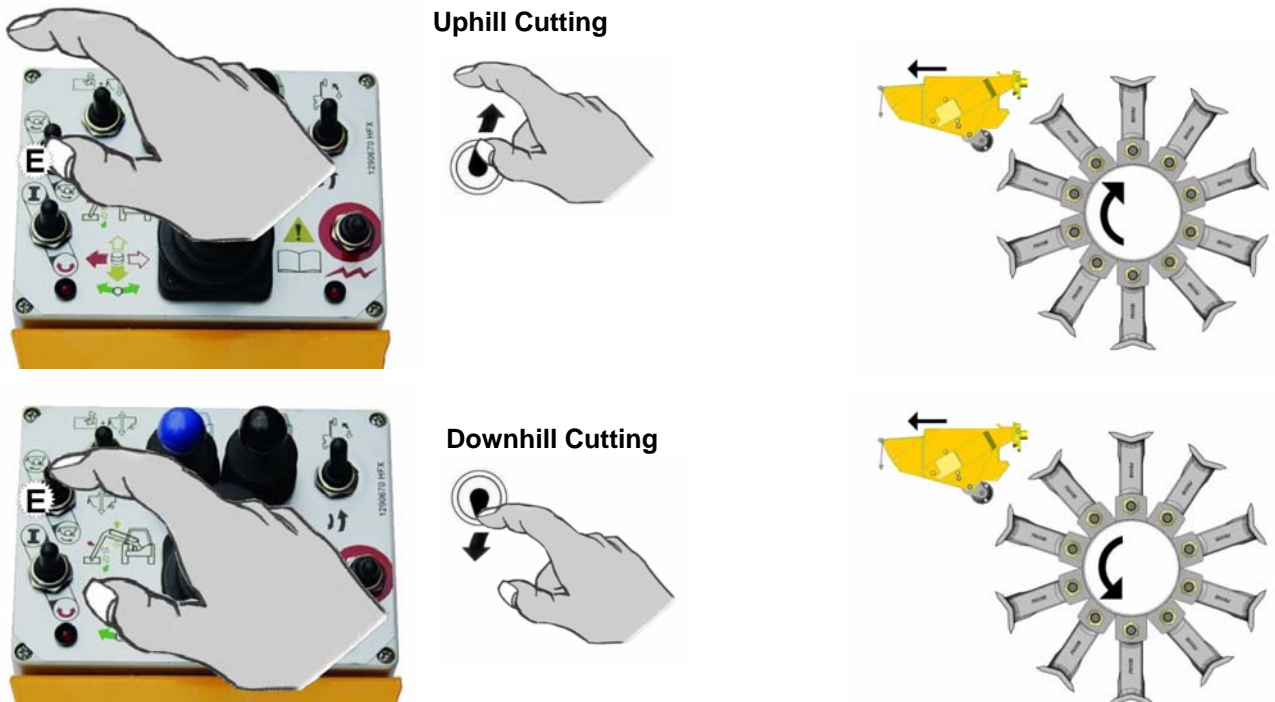

Switching the Rotor On

For safety reasons, to prevent accidental starting of the rotor, the 'Rotor On' switch cannot be activated in a single operation or without first selecting the direction of cut – the procedure for starting the rotor is as follows:

Select the required cutting direction - the Rotor On/Off Switch (D) must then be switched upwards and held in position for a minimum of 8 seconds before switching it into the fully down 'on' position where it will remain until it is switched off. When the switch is moved to the down position the red LED light below the switch will be lit to signify the rotor is on – if the LED does not light the switch was not held in its up position for long enough and the rotor will not have started, repeat the process again holding the switch upwards for a longer period.

Rotor Start

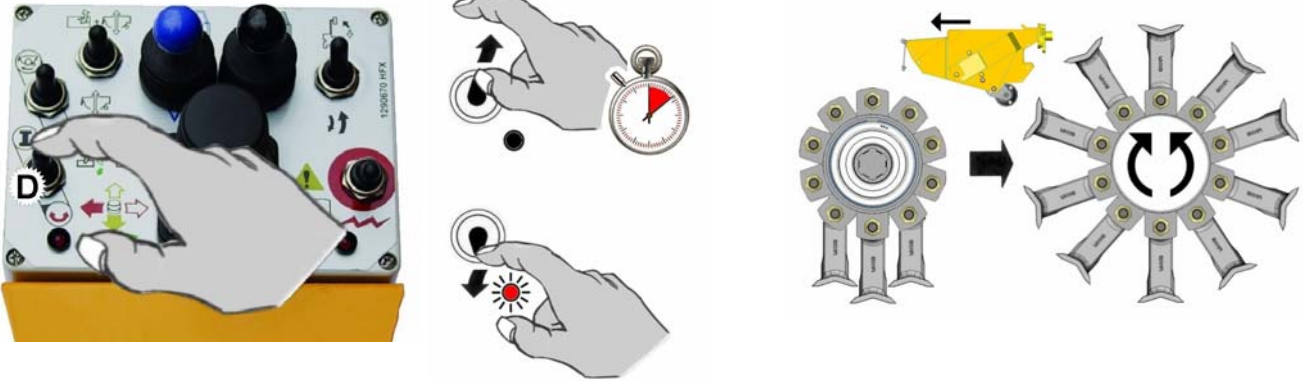

Switching the Rotor Off

Stopping the rotor is performed by switching either the Rotor Power Switch (D) or the Rotor Direction Switch (E) to the central (off) position – the red LED light will go out to signify the rotor has been switched off.



CAUTION: When the rotor is switched off it will continue to 'freewheel' under its own momentum for up to 40 seconds before finally coming to a standstill – do not leave the tractor cab or attempt to approach the flailhead until the rotor has stopped turning completely.

Rotor Stop

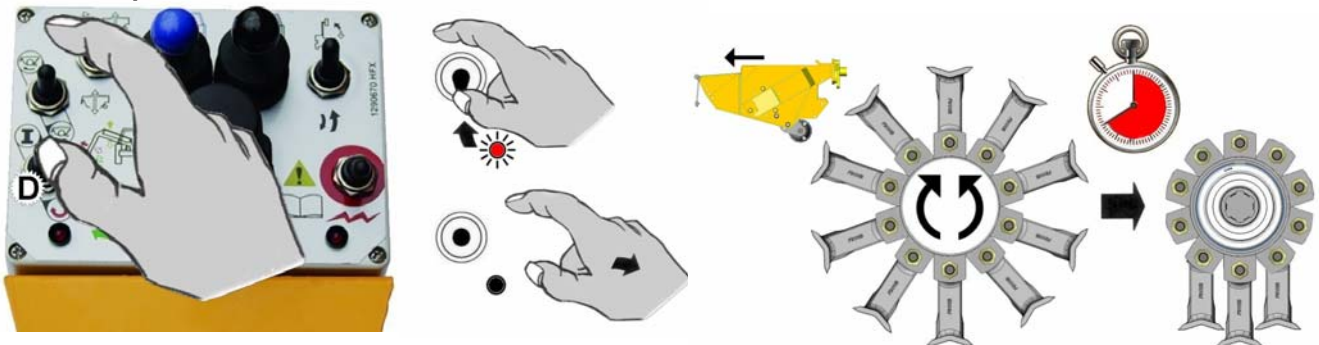

Alternative Rotor Stop

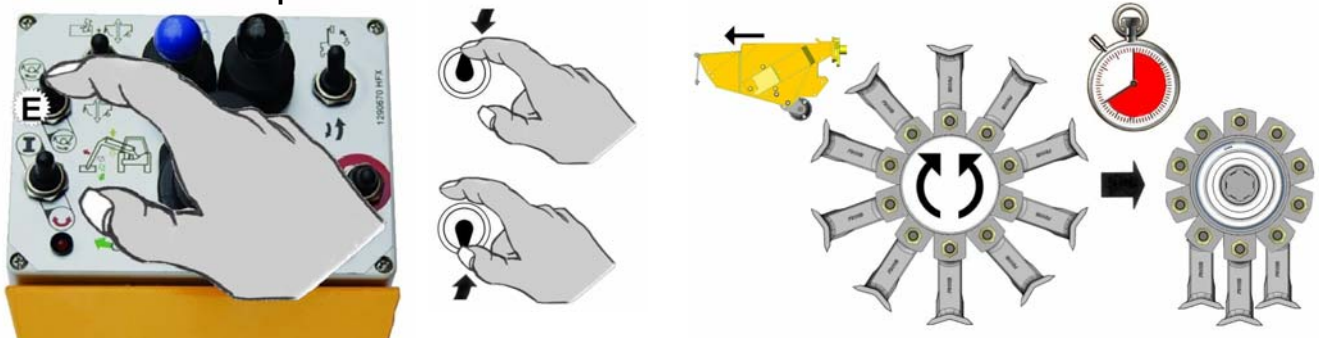

XTC (Mk2) PROPORTIONAL SWITCHBOX CONTROLS (5 Service Models)

Machines with XTC Mk2 Proportional Controls (5 service models) will be supplied with the control unit shown below. The units for both electric and cable controlled rotor machines are identical except that for cable versions the rotor control switches B, C & D (shown below) will not provide a function as rotor operation will be controlled by a separate cable lever unit (refer to specific cable rotor control page for operation details of that unit).

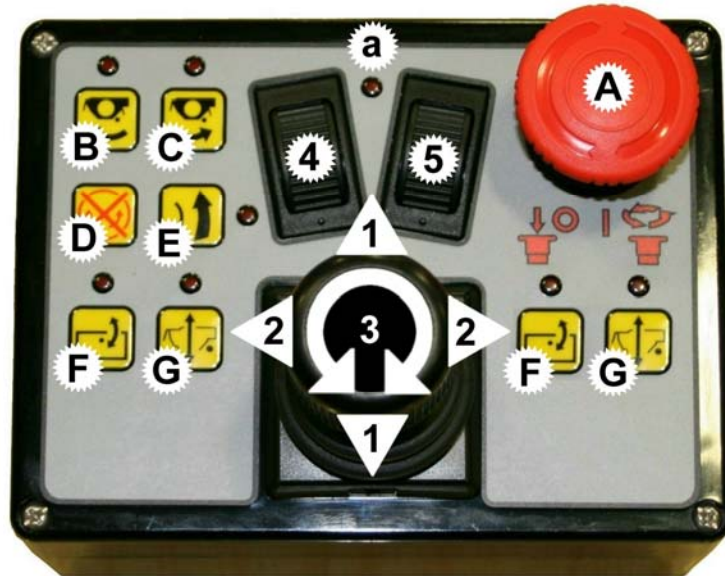

LOCATION & FUNCTION OF CONTROLS

- | | |
|---|---|
| 6. Arm Lift Control | A. Power On/Off (LED 'a' indicates status) |
| 7. Arm Reach Control | B. Rotor Start (Uphill Cutting Direction) |
| 8. Head Angle Control | C. Rotor Start (Downhill Cutting Direction) |
| 9. Arm Slew Control (Default Mode) | D. Rotor Stop |
| 10. Tele*/Midcut*/VFR* Control (Default Mode) | E. Auto Reset |
| | F. Head Angle Float On/Off |
| | G. Lift Float On/Off (Option) |

* Applies to the specific model only

Note: 2 sets of control buttons are installed on each side of the unit for operation of Angle Float & Lift Float, both sets of buttons and their LED's are linked and therefore perform exactly the same function; they are installed to allow for operator preference.

LED Lights

An LED light adjacent to each control button reports the status of that particular function – when the function is selected the LED light will illuminate to confirm the function is active; the light will switch off on de-selection of that function.

Powering the Controls

Activation of power to the control unit is by operation of the red button switch 'A' as shown below:

Rotate clockwise for **Power ON** (LED light on)

Press for **Power OFF / Emergency Stop** (LED light off)

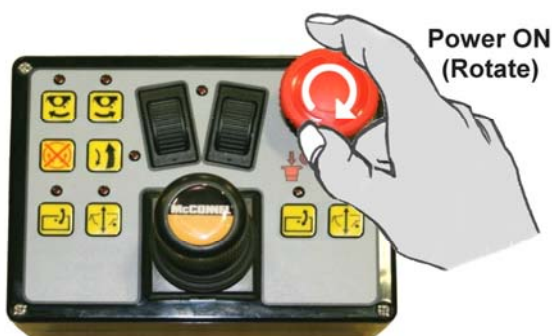

ARM OPERATION

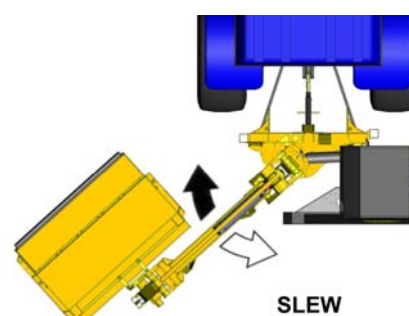
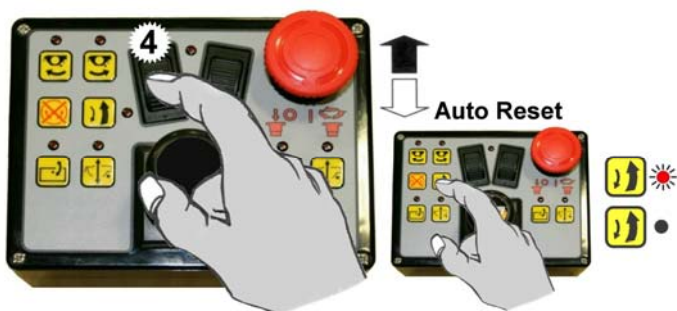
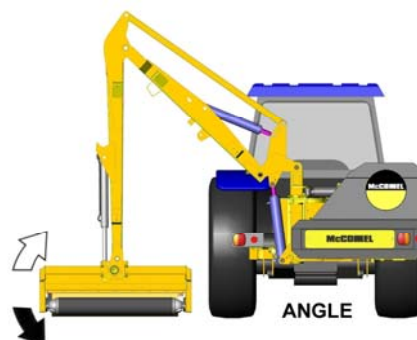
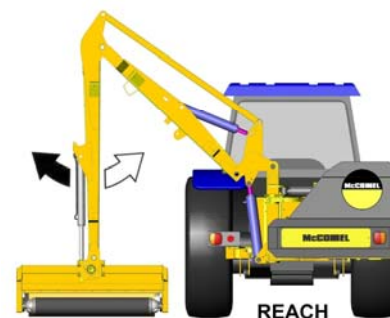
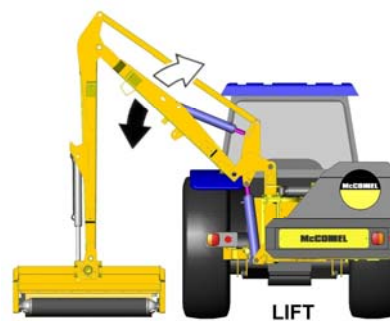

Tele or Midcut/VFR Models only

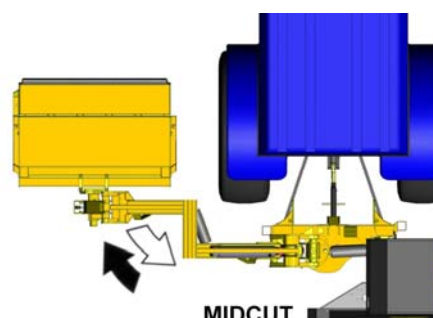
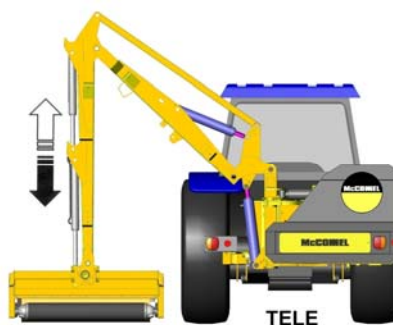

HEAD FLOAT OPERATION

Angle Float (Standard Feature)

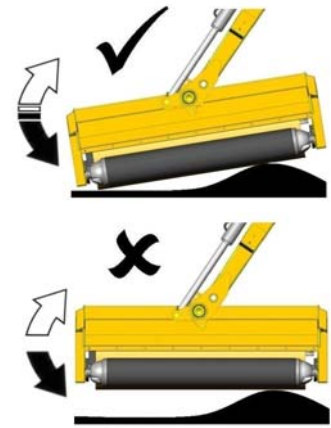

Lift Float (Optional Feature)

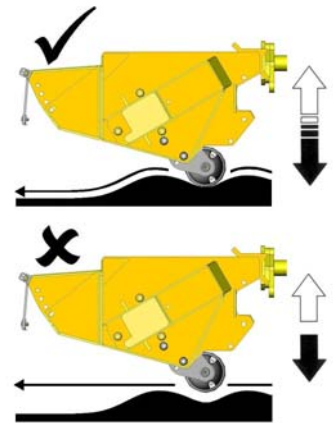

ROTOR OPERATION – Electric Rotor Control Models only

NOTE: The following section relates to machines with electric rotor control only – for cable rotor control models refer to the specific cable rotor control section.

Rotor Start (Selection of Rotor Cutting Direction)

Select rotor start for required direction (LED will light to indicate the active direction).

Uphill Cutting

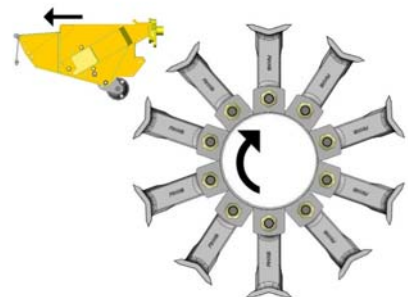

Downhill Cutting

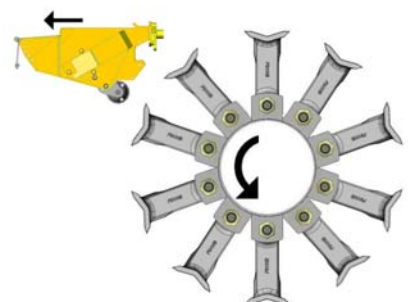

Switching Rotor Direction

With the rotor running, changing the rotor cutting direction can only be achieved after first operating 'rotor stop', when stop has been selected the specific direction button can then be operated to command the rotor to switch to the desired direction. NOTE: This function has a built in time delay of approximately 8 seconds - this is a machine protection feature that allows the rotor sufficient time to de-accelerate before restarting in the opposite direction. The LED light of the active cutting direction will flash on and off during the slowing down period, when the direction has changed the LED for the new direction will be illuminated.

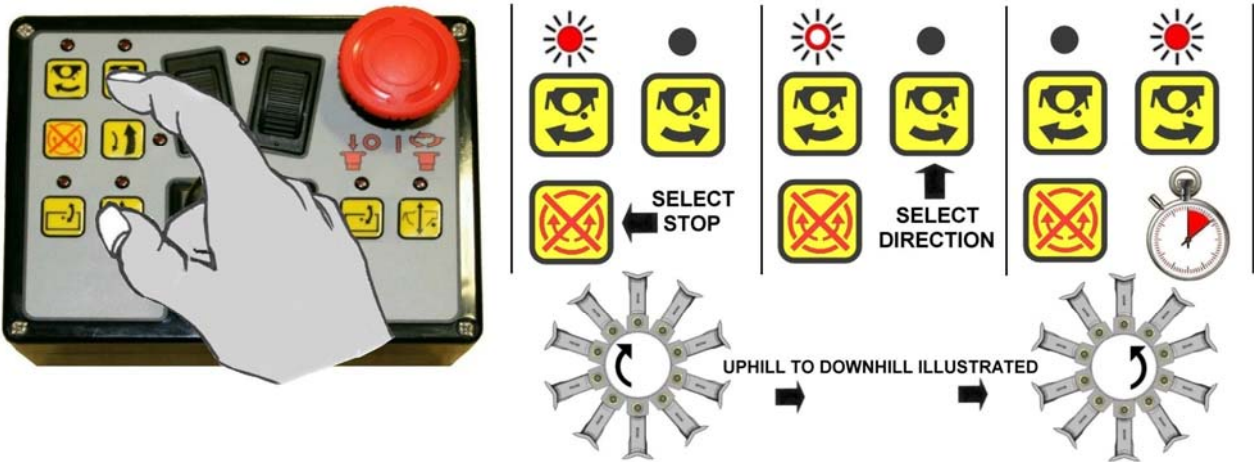

Switching the Rotor Off

Stopping the rotor is performed by operation of the rotor stop button as illustrated below. When rotor off has been selected the LED light above the button of the active cutting direction will flash on and off for approximately 8 seconds to signify that the rotor has been switched off, after this 8 second period the light will go off completely. NOTE: The rotor will continue to rotate under its own power until it finally comes to a standstill.

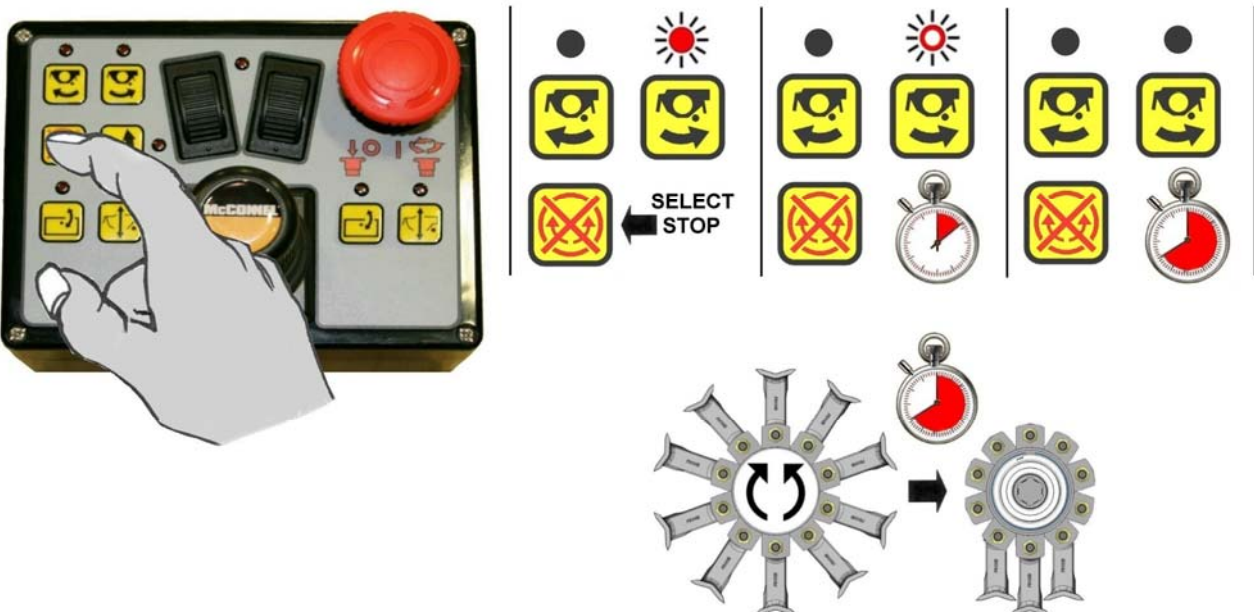

CAUTION: When the rotor is switched off it will continue to 'freewheel' under its own momentum for up to 40 seconds before finally coming to a standstill – do not leave the tractor cab or attempt to approach the flailhead until the rotor has stopped turning completely.

V4 PROPORTIONAL CONTROLS - Buttons & Thumbwheels Operation



NOTE: By default operation of thumbwheels T1 and T2 in conjunction with button B1 activates Head Angle Float and EDS/Lift Float respectively. These controls can, if required, be swapped over so that the thumbwheels operate the opposing functions – this procedure is performed by accessing the settings menu on the control unit via the screen and menu buttons.

Float Selection & De-Selection

Operate thumbwheels to their furthest points (+ or -) to select or deselect float functions.

FLOAT ACTIVATION

Hold button B1 in conjunction with Thumbwheel T1 or T2 operation to activate required float mode - thumbwheels must be rotated to their furthest point to select or de-select the feature

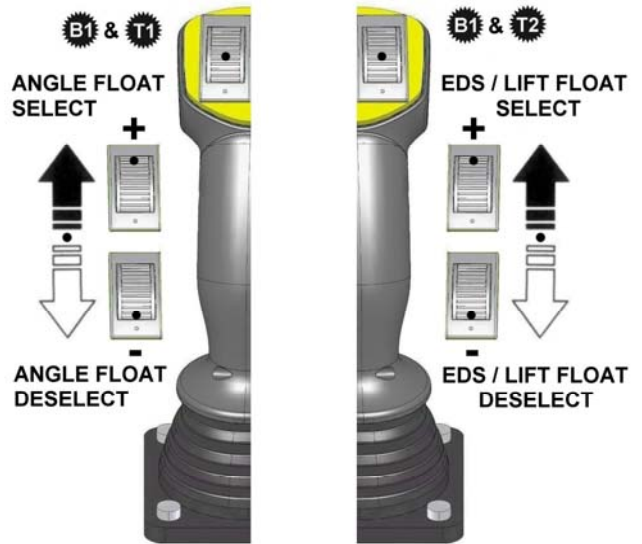

Angle & Slew Operation

Rotate thumbwheels in required direction.

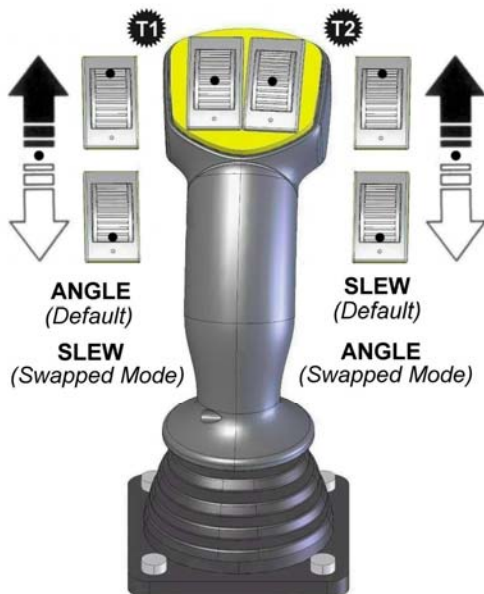

Diverter Valve Selection

Diverter selection is via button B2



DIVERTER VALVES
 Press once to activate DV #1
 Press & hold to activate DV #2
 (de-activated on release of button)

ARMHEAD OPERATION – V4 JOYSTICK CONTROLS

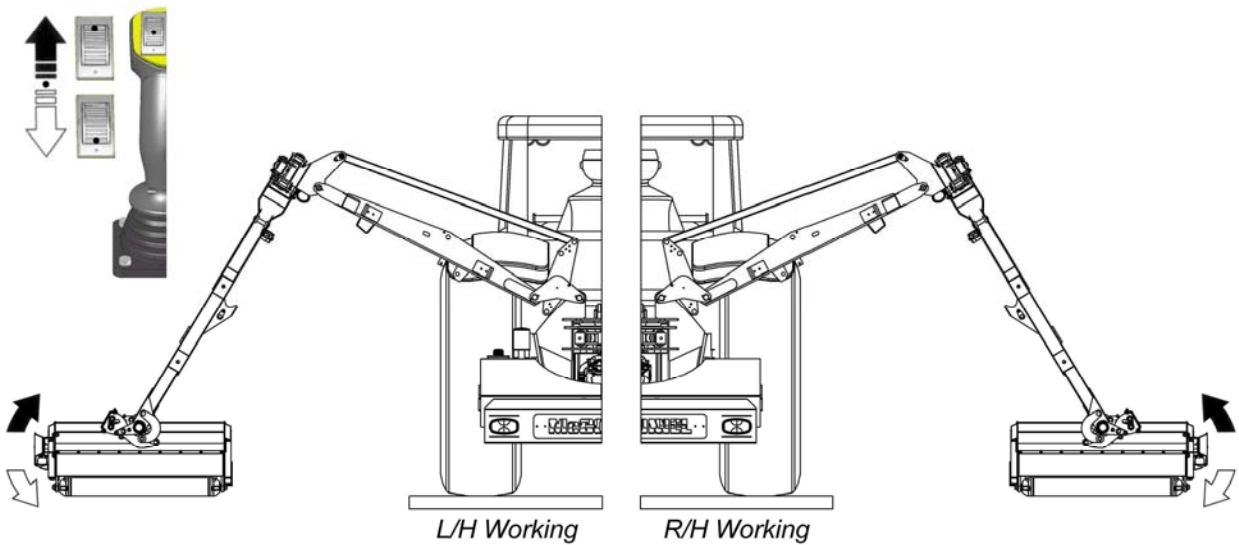
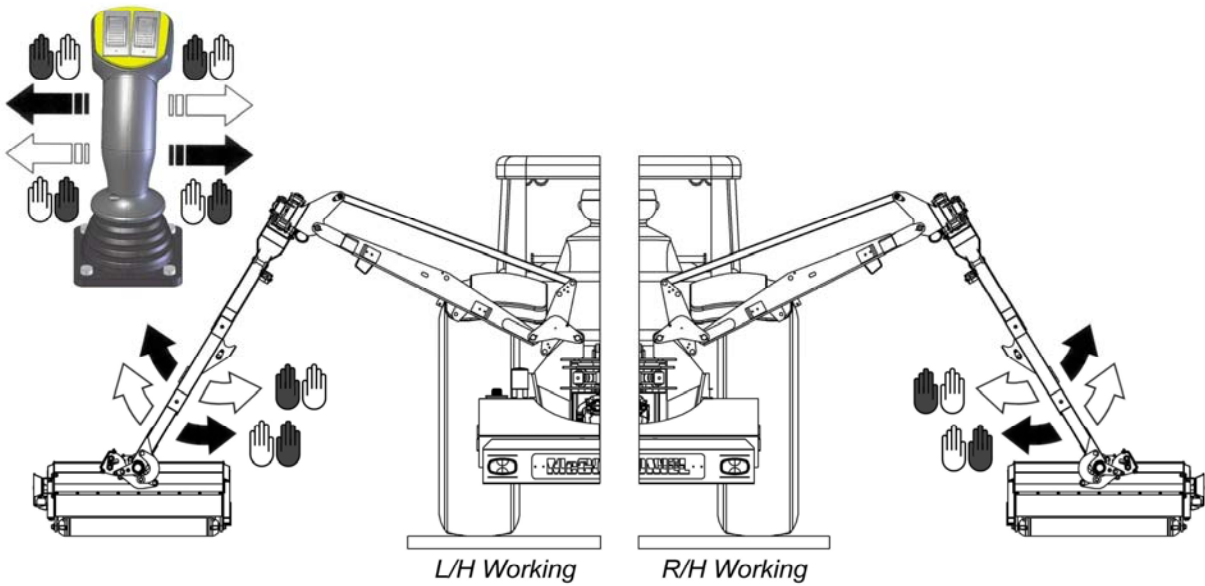
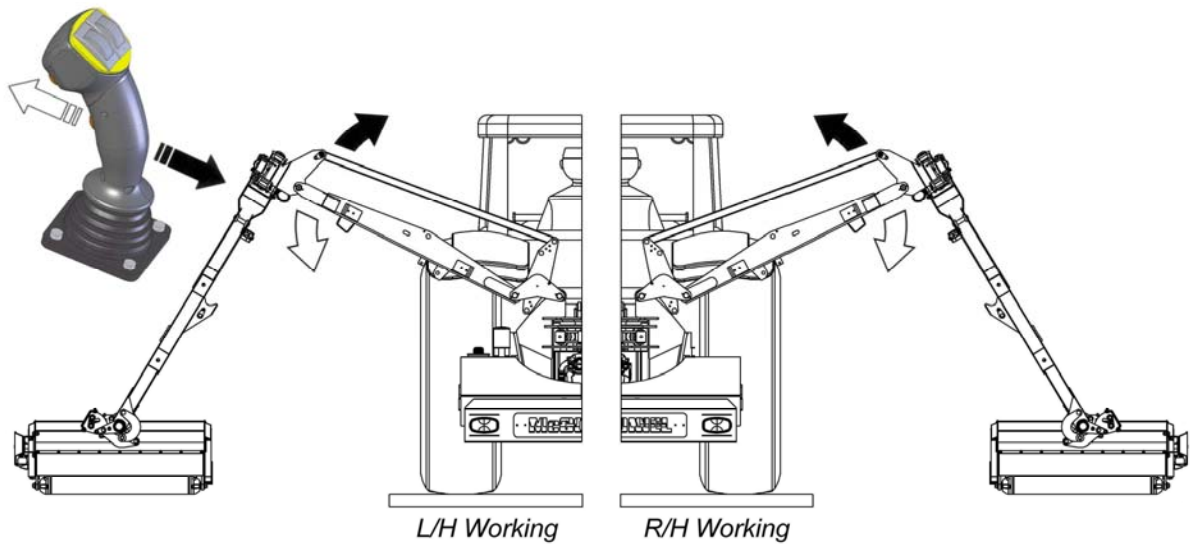

NOTE: Illustration shows the left hand thumbwheel as the default angle control, this can be swapped within the settings to the right hand thumbwheel if desired.

Power ON / OFF (Emergency Stop)

Rotate Clockwise to Power On – control unit will emit a single beep and screen will display the selected PTO speed, software version and the McConnel name. Press to Power Off.

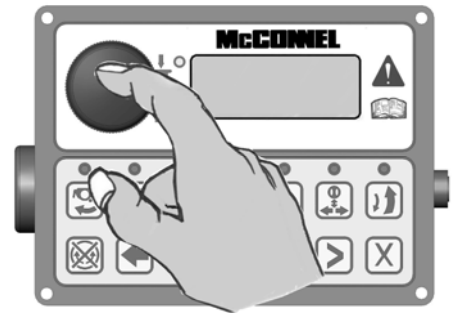
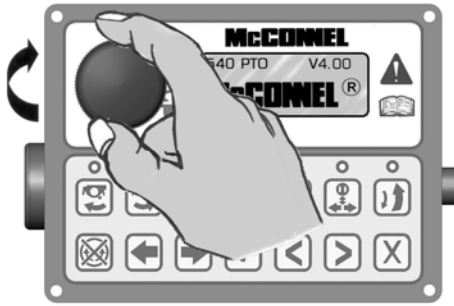

Rotor Start – Uphill Cutting

This button starts the rotor for ‘uphill’ cutting – when the button is pressed the control unit will emit a single beep, the LED light will illuminate and the screen will momentarily display ‘FLAIL START ✓’.

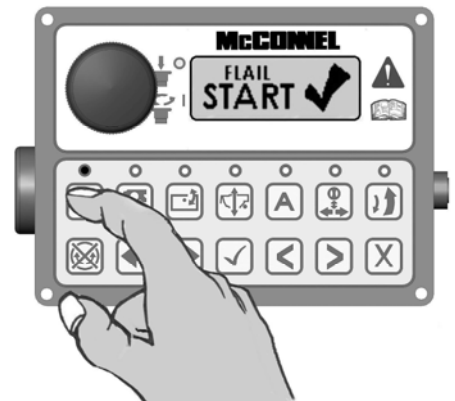

Rotor Start – Downhill Cutting

This button starts the rotor for ‘downhill’ cutting – when the button is pressed the control unit will emit a single beep, the LED light will illuminate and the screen will momentarily display ‘FLAIL START ✓’.

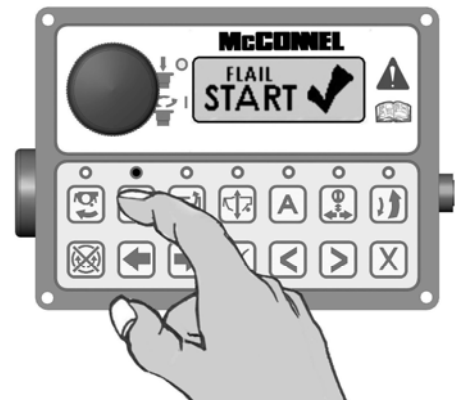

Rotor Stop

This button stops the rotor – when the button is pressed the control unit will emit a single beep and the screen will momentarily display ‘FLAIL STOP ✓’ – the LED lights above both rotor start buttons will be illuminated for approximately 10 seconds, during this period the rotor start buttons will be disabled to allow sufficient time for the rotor to power down. When the LED lights go out the rotor direction can be changed or the rotor allowed to stop.

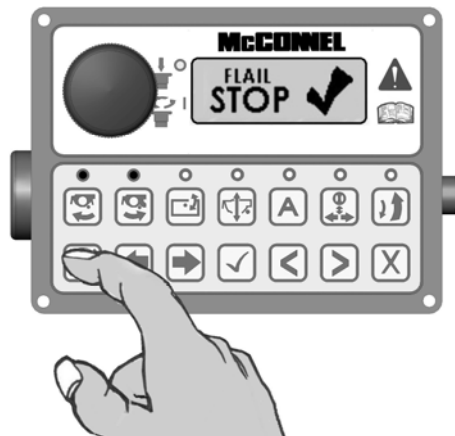

WARNING: The LED lights going out do not indicate that the rotor has stopped rotating, it signifies only that the oil flow to the rotor has ceased sufficient for the direction of rotation to be changed - therefore when stopping a rotor it must be noted that it will continue to freewheel for a considerable length of time after the stop button has been activated, in some case this can be up to 40 seconds.

HEAD ANGLE FLOAT

There are 2 methods available for selection and de-selection of this function; activation via the control unit - refer to #1 below, or activation via the joystick controls - refer to #2 below.

1. Pressing the Head Angle Float button – when activated the control unit will emit a single beep, the LED light will illuminate and the screen will momentarily display 'ANGLE FLOAT ✓' pressing the button again will deselect the function – the control unit will emit a single beep, the LED light will go out and the screen will momentarily display 'ANGLE FLOAT X'.

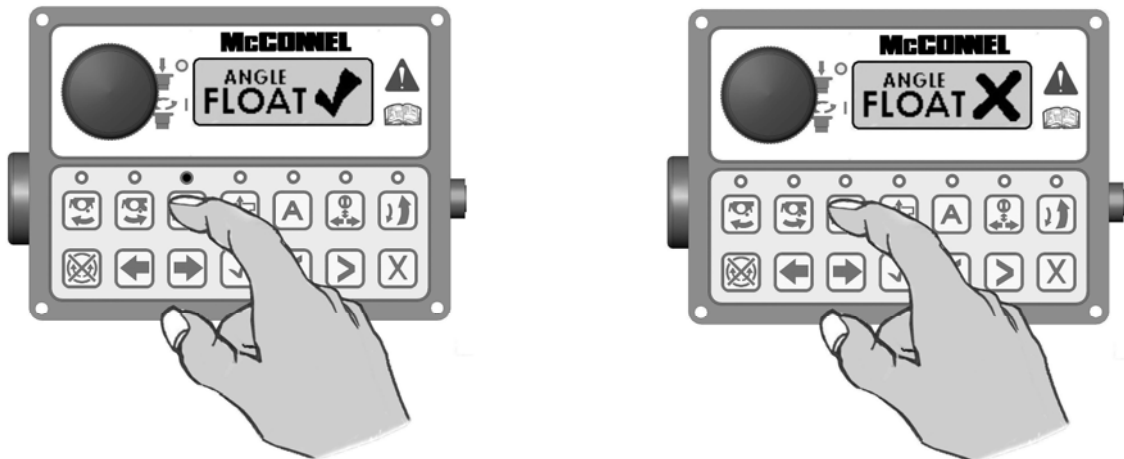

2. Press and hold in the lower frontal button (B1) on the joystick control and roll the left hand thumbwheel (T1) fully forwards – the control unit will emit a single beep, the LED light will illuminate and the screen will momentarily display 'ANGLE FLOAT ✓'.

To deselect press and hold in the lower frontal button (B1) on the joystick control and roll the left hand thumbwheel (T1) fully backwards – the control unit will emit a single beep, the LED light will go out and the screen will momentarily display 'ANGLE FLOAT X'.

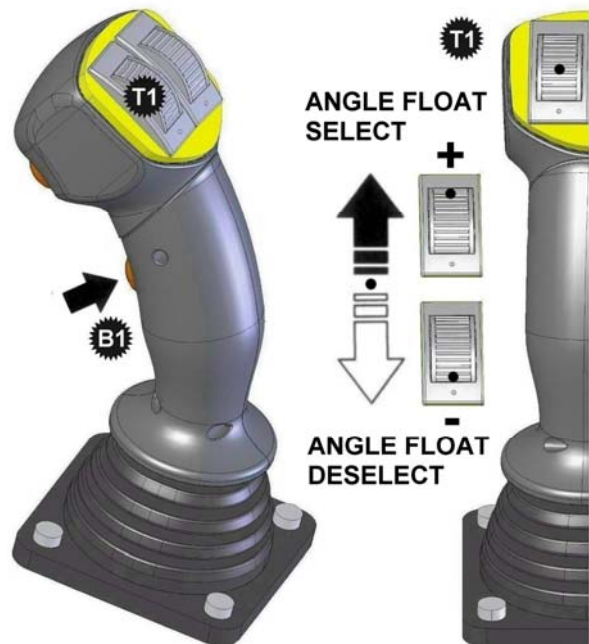

NOTE: When selecting or deselecting the function, the thumbwheel (T1) should be allowed to return to its centre position before releasing the lower frontal button (B1).

EDS FUNCTION (EDS Models) / LIFT FLOAT (Non EDS Models)

There are 2 methods available for selection and de-selection of this function; activation via the control unit - refer to #1 below, or activation via the joystick controls - refer to #2 below.

1. Pressing the EDS / Lift Float button will activate the relevant function – when activated the control unit will emit a single beep, the LED light will illuminate and the screen will momentarily display 'LIFT FLOAT ✓'. Pressing the button again will deselect the function – the control unit will emit a single beep, the LED light will go out and the screen will momentarily display 'LIFT FLOAT X'.

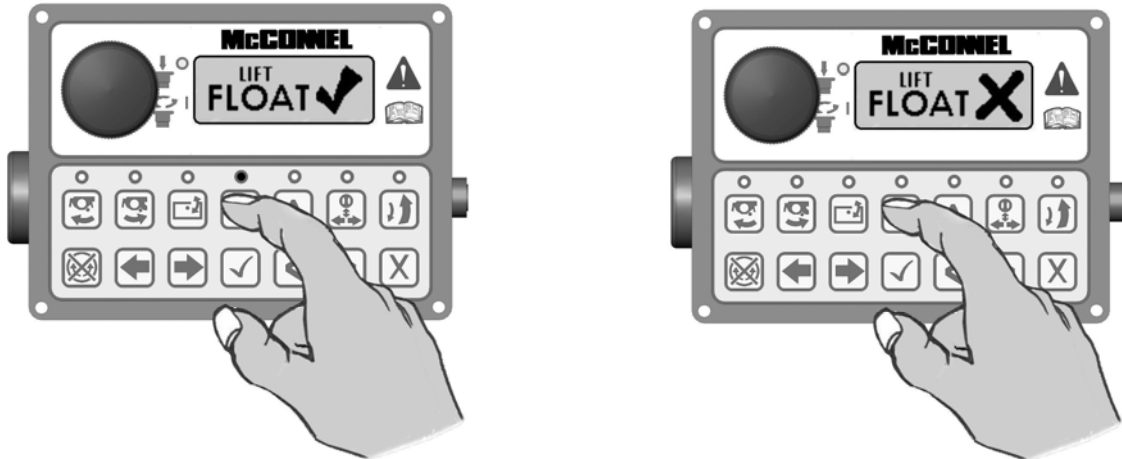

2. Press and hold in the lower frontal button (B1) on the joystick control and roll the right hand thumbwheel (T2) fully forwards – the control unit will emit a single beep, the LED light will illuminate and the screen will momentarily display 'LIFT FLOAT ✓'. To deselect press and hold in the lower frontal button (B1) on the joystick control and roll the right hand thumbwheel (T2) fully backwards – the control unit will emit a single beep, the LED light will go out and the screen will momentarily display 'LIFT FLOAT X'.



NOTE: When selecting or deselecting the function, the thumbwheel (T2) should be allowed to return to its centre position before releasing the lower frontal button (B1).

In the case of EDS models once this function is engaged and the rotor is running the EDS settings (SOFT – MED – HARD) will automatically be displayed on the control unit screen and can be scrolled through using button B1 on the joystick or the tick [✓] button on the control unit, if the rotor is not running the EDS settings can manually be viewed on the screen by pressing either [◀] [▶] buttons on the control unit and scrolling to the EDS work screen. When not in the EDS work settings screen, operation of button B1 activates the Slew/Tele swap function.

AUXILIARY FUNCTION CONTROL

This control selects either of the two diverter valves for the operation of additional equipment that may be fitted to the machine such as: Directional Ram, Orbiter Head Kit, Hydraulic Roller etc. There are 2 methods available for selection and de-selection of this function; activation via the control unit - *refer to #1 below*, or activation via the joystick controls - *refer to #2 below*.

1. Pressing the button momentarily will select Diverter Valve #1 – when activated the control unit will emit a single beep, the LED light will illuminate and the screen will momentarily display 'DIVERTER ON ✓'.
Holding the button in will select Diverter Valve 2.

NOTE: Diverter Valve #2 operates only whilst its selection button is held in – releasing the button will de-activate the valve.

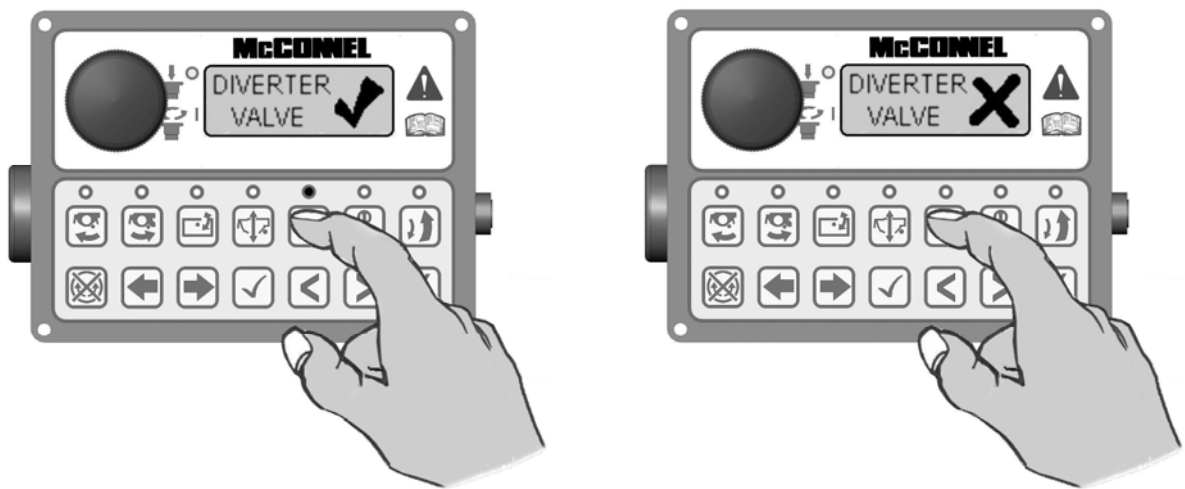

2. Pressing the upper frontal button (B2) on the joystick momentarily will select Diverter Valve #1 – when activated the control unit will emit a single beep, the LED light will illuminate and the screen will momentarily display 'DIVERTER ON ✓'.
Holding the button in will select Diverter Valve #2.

NOTE: Diverter Valve #2 only operates whilst its selection button is held in – releasing the button will de-activate the valve.



Button B2 not available on some models.

Power on/off switch (E/Stop)

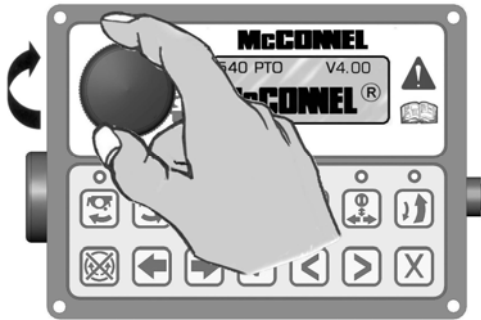

Speaker (audible confirmation)

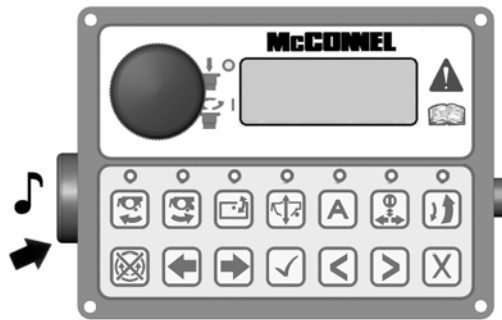

Command Button [✓]

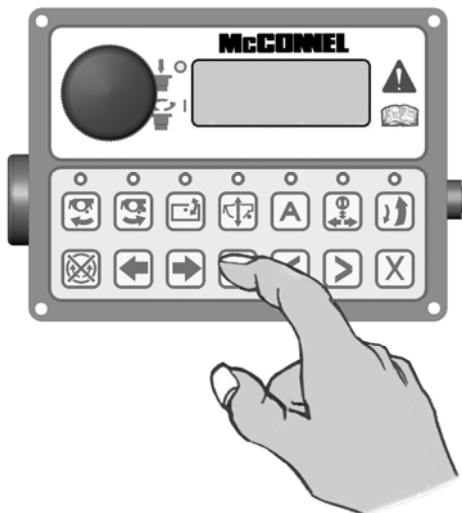

Command Button [X]

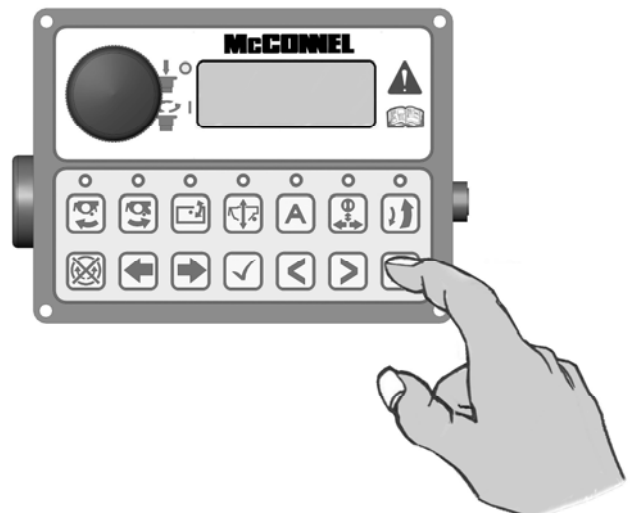

Navigate Forward Button [>]

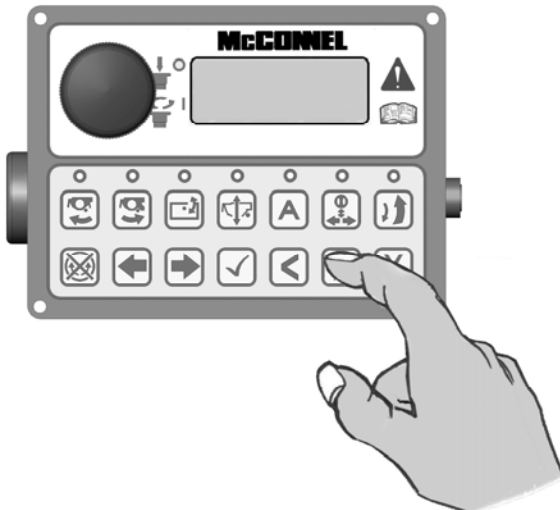

Navigate Back Button [<]



V4 CONTROL UNIT – LED Screen Display & Functions

IMPORTANT: Under no circumstances should a V4 Control Unit be connected to a V3 ACB (Auxiliary Control Box). Dedicated V3.5 & V4 Upgrade Kits are available from McConnell Limited – contact your local dealer or McConnell direct for available options and specific advice on this subject.

Rotate the ON/OFF switch on the control unit clockwise to power up controls - unit will emit a single beep and the LED screen will light up. Note: 12 Volts at the battery are required for correct function.

1. Screen will initially display the 'McConnel' name along with the selected PTO speed and the software versions installed on the Armrest and the Control Box respectively.

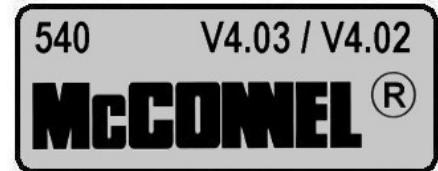

2. Pressing the scroll forward [▶] button once will display the rotor running times screen. 'TOT' displays the overall total running time of the rotor which is a cumulative total and cannot be reset. 'JOB' is a 'trip' total for the current rotor running time and can be reset to zero by pressing and holding the [X] button for 3 seconds.



3. Pressing either of the 'Rotor On' buttons will activate the 'egg timer' icon and display the rotor on image.



4. Pressing the EDS Lift float button will turn on the EDS (EDS Lift Float machines only). Then SOFT, MED or HARD will be added to the running screen.



5. Pressing the tick [✓] button when EDS is turned on will scroll through the EDS work settings of SOFT, MED or HARD. This may also be operated via button B1 on the joystick.



6. Pressing scroll forward [▶] button will now display the actual Tractor PTO running speed.



7. Scrolling forward [▶] again displays the Power Monitor screen.



Scrolling backwards [◀] will display the screens in the opposite order.

POWER MONITOR

When displayed the power screen will indicate to the operator the level of power being demanded by the cutting head – an ascending graphic indicates the power demand status from minimum on the left of the screen to maximum on the right.

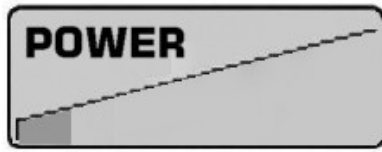

Power Status – Low Demand



Power Status – High Demand

When the power demand approaches the maximum limit an audible warning will alert the operator to indicate that the rotor is under excess load and at risk of ‘stalling’ – when this audible warning sounds the operator should reduce the forward tractor speed to protect the machine and regain efficient cutting power – the audible warning will cease when the power demand returns to an acceptable level.

In certain cases, cutting materials of extreme density may cause an increase in the power usage to the ‘warning level’ – in these types of conditions raising the cutting head into a less dense area of the material will regain an acceptable power demand. It is advisable that work in problematic high density materials be performed in several passes, lowering the cutting head slightly on each pass until the required cut height is achieved.

ADDITIONAL CONTROL & SCREEN SETTINGS

Additional settings available to the operator can be found within the settings menu of the control unit and accessible via the screen and menu buttons on the control panel.

Access is gained by simultaneously pressing the scroll [◀] [▶] buttons on the control panel until the unit emits a ‘beep’ and the setup screen appears on the LCD - the features can then be ‘scrolled’ to (forwards or backwards) by subsequent operation of either of the scroll [◀] [▶] buttons. When the required screen is reached the tick [✓] button should be pressed to enter the settings menu for that feature.

Thumb (Thumbwheel Switching) – this allows the operator to ‘swap over’ the left and right thumbwheel functions so that they control the opposing features. In most cases this setting will be dictated by the operators’ personal preference and once chosen the operator will keep it in the selected mode.

Options are ‘Normal’ or ‘Swap’ – selection is by ‘highlighting’ the required option using either of the scroll [◀] [▶] buttons – the feature is then activated using the tick [✓] button. Pressing the [X] button exits the screen settings and returns to the normal work screen.

LED (Screen Contrast) - this setting allows the operator to adjust the contrast level of the LED display – the feature affords the option to increase or decrease the contrast level to suit differing lighting conditions; this is particularly useful on dull or sunny days where reduced or increased natural light can affect screen clarity.

Options are ‘Increase Contrast’ or ‘Decrease Contrast’ – selection is by ‘highlighting’ the required option using either of the scroll [◀] [▶] buttons – once selected that particular option can then be adjusted in incremental steps by pressing the tick [✓] button the required number of times to achieve the desired contrast. Pressing the [X] button exits the screen settings and returns to the normal work screen.

CAUTION: Avoid adjusting the contrast level to a state where the screen cannot be viewed as exiting the settings menu in this condition may render the LCD unusable as the ‘on screen’ prompts may no longer be visible to the user.

NOTE: Some screen menus are inaccessible to the operator – these are for factory or dealer use only and are password protected to avoid inadvertent changes to specific control settings.

TEST & FAULT FINDING SCREENS

The following screens are available for testing and fault finding purposes, these are:

Joystick Test Screen

This screen reports the status of the CAN (*Controller Area Network*) signal from the joystick during its various functions.

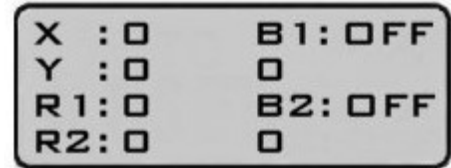

X and Y Display

These report the joystick signal as it travels through its range of movements in its 2 axis – the 'X' axis being the 'Lift' up and down function and the 'Y' axis the 'Reach' in and out function.

With the joystick in the central (*neutral*) position both 'X' and 'Y' on the screen should read 0 (*zero*). When the joystick is moved through a specific axis the relevant readout will increase or decrease depending on the direction and distance of movement up to a maximum of +1000 in the fully forward or fully right position and -1000 in the fully back or fully left position. If the display reports a reading above the + or – 1000 figure at any point of full travel the joystick has developed a fault and should be repaired or replaced.

R1 and R2 Display

These report the signals from the 2 thumbwheels on the top of the joystick and are calibrated to read +1000 in the fully back position and -1000 in the fully forward position. If either of the 'R' readings are above the + or – 1000 figure at the point of full travel the thumbwheel has developed a fault and should be repaired or replaced.

B1 and B2 Display

These report the status of the 2 joystick buttons and will display 'ON' when the button is activated or 'OFF' when deactivated. The readings below B1 and B2 on the screen record usage of the buttons.

EDS Status Screen

Although this screen is present on all V4 controls, with the exception of the voltage reading, the information it reports is only actually relevant to machines fitted with EDS.

In addition to the aforementioned voltage reading the screen will report Lift Ram Pressure and Reach Position status – in each case these will display 'OK' when the system is working correctly. If 'FAULT' is displayed next to one or other feature it means a problem has been detected with that component and it should be investigated further to locate and correct the problem.

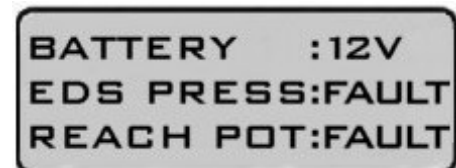
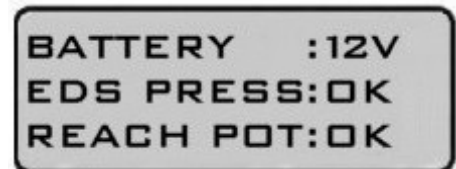

NOTE: As the pressure and position features are not present on Non EDS machines by default the screen will display 'FAULT' next to the features on these models – this is normal and should be ignored. The voltage reading will be relevant on all models.

Reach Function Screen

This screen displays the status of the joystick reach function and indicates to the operator if the controls are set for correct operation of the machine to the left hand side of the tractor or to the right hand side of the tractor. The hand symbol with a ✓ displayed on it indicates the operating side that is currently active.



L/H Machine Operation



R/H Machine Operation

PRE-OPERATIONAL CHECKS

Check all bolts are tight and that the torque figures are correct for the specific locations indicated below:

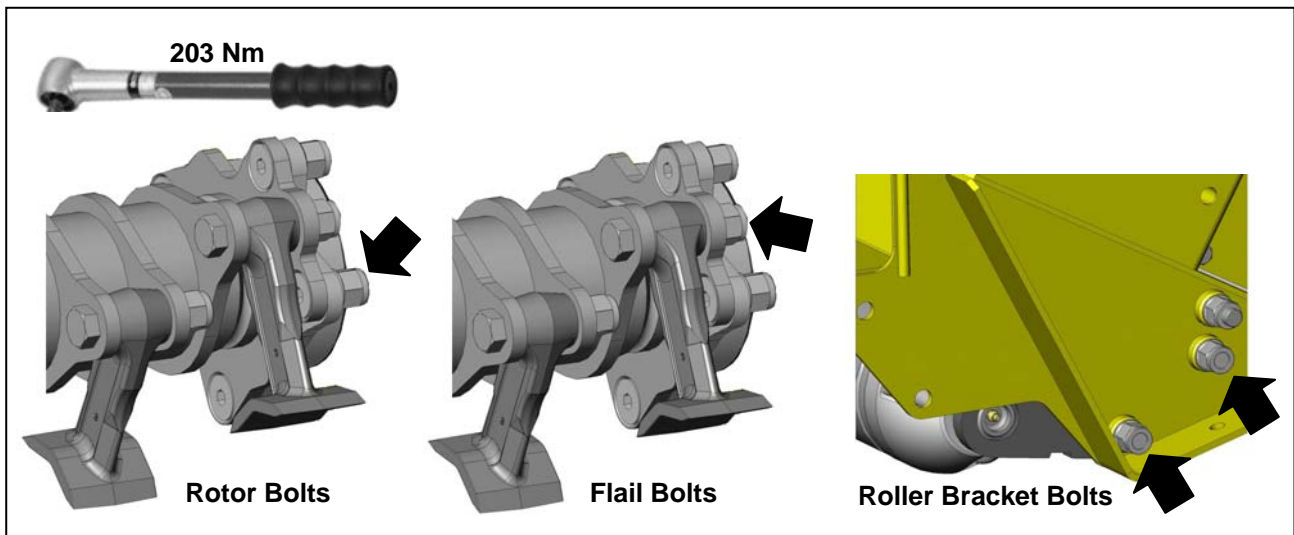
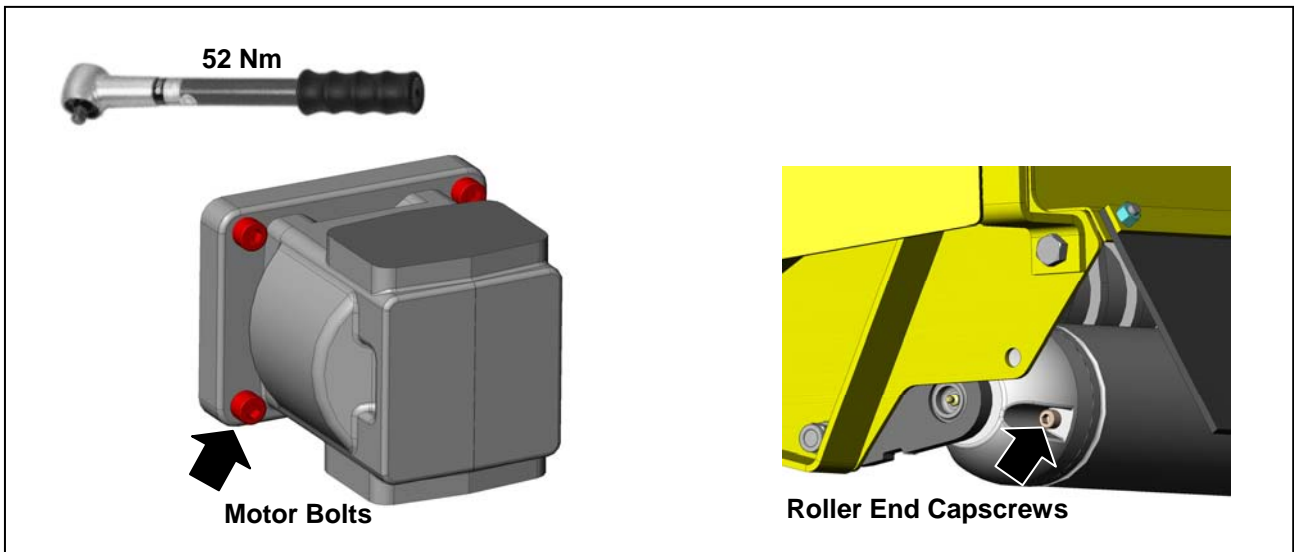

IMPORTANT!

On the first day of use with a new flailhead, nuts should be checked for tightness every hour and retightened if required. Thereafter they should be checked on a daily basis prior to use of the machine. Torque nuts to the settings stated above.

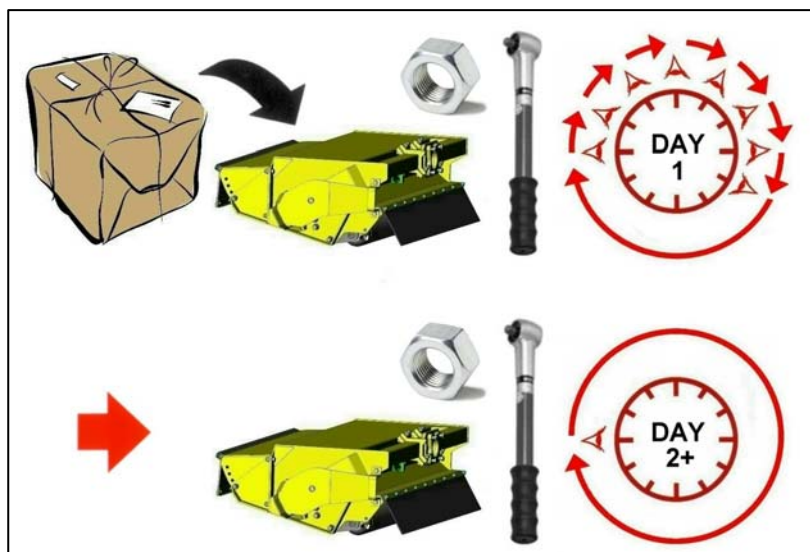

MOVING INTO TRANSPORT POSITION

When transporting on the highway the arms should be latched securely in the broken back position and the tap on the lift ram screwed fully in.

To achieve this position angle the flail head and place one corner of it on the ground. Raise the latch; drive forward and simultaneously select 'lift down'. Release the latch and check that it is fully engaged. Raise and fold the machine into the transport position taking care not to hit the tractor cab or mud wing. Screw the lift ram in fully to prevent any droop.

When transporting the machine always ensure;

- Arms are latched in the 'broken back' position.
- PTO is disengaged.
- Lift ram tap is closed.
- Power to control box is switched off (*where applicable*).

Transport Speed

The acceptable speed of transport will vary greatly depending upon the ground conditions. In any conditions avoid driving at speed which causes exaggerated bouncing as this will put unnecessary strain on the tractors top hit position.

Transport Height

There is no fixed dimension for transport height as this will vary depending on the size of the carrying vehicle and the height it is carried at. The operator should make themselves aware of the machines height at all times especially when maneuvering under or near overhead obstructions or buildings.

Moving from Transport to Work Position

Unscrew the lift ram tap fully. Lower the flail head flat to the ground and release the transport latch, if it does not release take the weight off the latch by easing the tractor forward slightly. The working position can be achieved by either reversing the tractor or by operating the lift ram to raise the head which allows the breakaway mechanism to position the flail head for work.

OPERATION

Material Thickness Cutting Limitations

Under normal conditions the machine is capable of cutting soft types of hedge material up to 80mm thick, and hard types of hedge material up to 40mm thick.



Operator Guard

Ensure operator protection guarding is correctly fitted to the working side of the tractor.

Read the book first

Ensure the operator has read the book first. Practice operating the machine in an open space without the rotor running until familiar with all aspects of the machine and its controls.

CAUTION!

Take extra care when working with the flail head close in as it can hit the tractor.

Engaging Drive - TI Models

Ensure that the rotor control lever is in the 'Stop' position before engaging the PTO shaft. Allow the oil to circulate for a minute or so before operating the armhead levers. Position the flail head in a safe position, increase the engine speed to a high idle and move rotor control lever to 'Start', after initial surging the rotor will run at an even speed.

Engaging Drive - SI Models

Place the flail head at a safe attitude and bring the tractor engine revs to 1000rpm. Engage the PTO and slowly increase revs until operating speed is attained.

Reversing Rotation - SI Models only

Fully extend the armhead and lower flail to the ground (*this will minimise oil loss*).

Release the hoses from the rotor relief valve and interchange (*).

(* **IMPORTANT:** *Do not interchange the flail supply and return hoses at any other point as the hose routing and cross overs in the installation are necessary to allow the hoses to flex correctly during normal arm movements.*

To ascertain the direction of cut without running the machine the following applies;

Connection P - (lower motor rigid pipe) }
Connection MR - (Upper motor right pipe) } **upward cutting direction**

Connection P - (Upper motor rigid pipe) }
Connection MR - (Lower motor rigid pipe) } **downward cutting direction**

Rotor Operating Speed

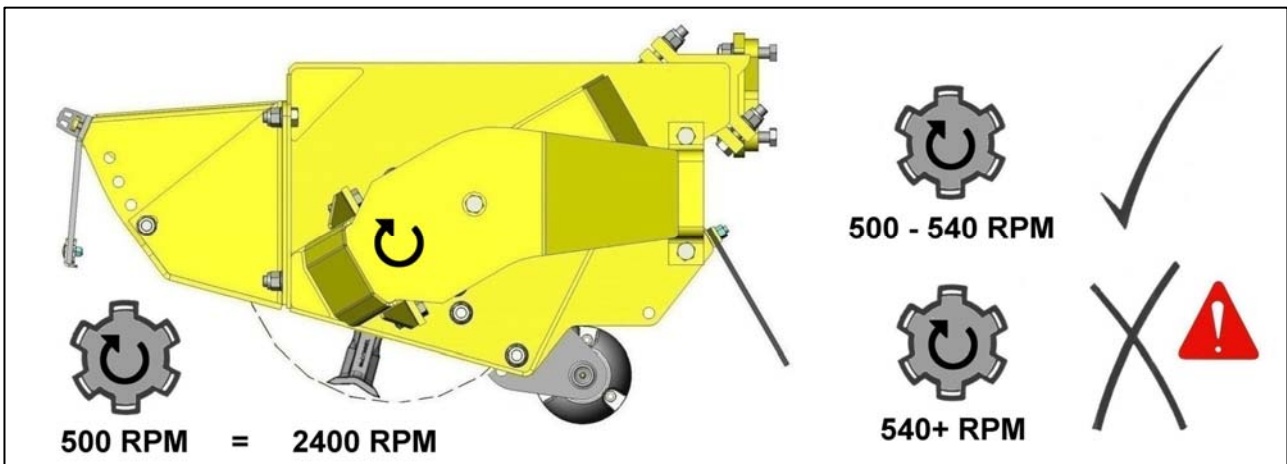

Tractor Forward Speed

The material being cut determines tractor forward speed. Forward speed can be as fast as that which allows the flail head sufficient time to cut the vegetation properly.

Too fast a speed will be indicated by over frequent operation of the breakaway system, a fall off in tractor engine revs and a poor finish to the work leaving ragged uncut tufts and poorly mulched cuttings.

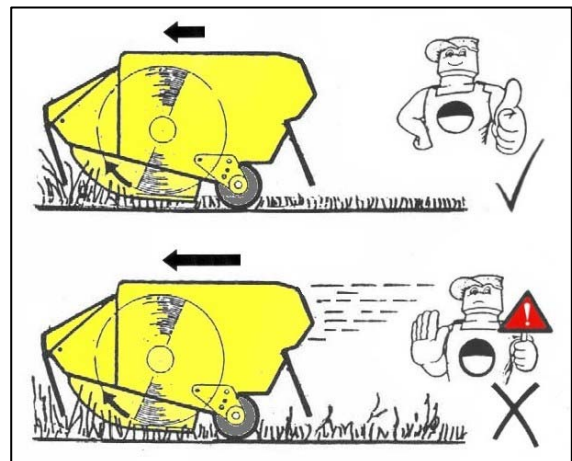

Highway Working

Local highway working regulations must be observed at all times.

WARNING!

It is the operators' responsibility to observe all local regulations and ensure that bystanders are kept at a safe distance at all times.

General Working Practices

It is the operators' responsibility to develop, and adhere to, safe working practices;

Always;

- *Be aware of hazards in the vicinity*
- *Make sure all guards are in position and in good condition.*
- *Disengage P.T.O. before stopping the engine.*
- *Wait until the flail has stopped running before leaving the tractor seat.*
- *Disengage the P.T.O. and stop the tractor engine before making any adjustments.*
- *Check frequently that all nuts and bolts are tight.*
- *Keep bystanders at a safe distance.*

Breakaway System

The machine is fitted with an automatically resetting power-assisted gravity breakaway system; this protects the machine and its components from damage should an obstruction be encountered during operation. The breakaway system utilizes a pre-loaded spring; the pre-load is factory set and non-adjustable.

Breakaway reset forces are absorbed by a pre-tensioned hollow rubber spring unit. The breakaway geometry is such that there is a possibility of an unstable condition occurring when in the broken back position at full height. When operating in conditions where there is any likelihood of this happening e.g. when cutting high hedges on sloping ground the latch must always be in the lowered position. Where it will act as an abutment stop.

Hedgecutting Procedure

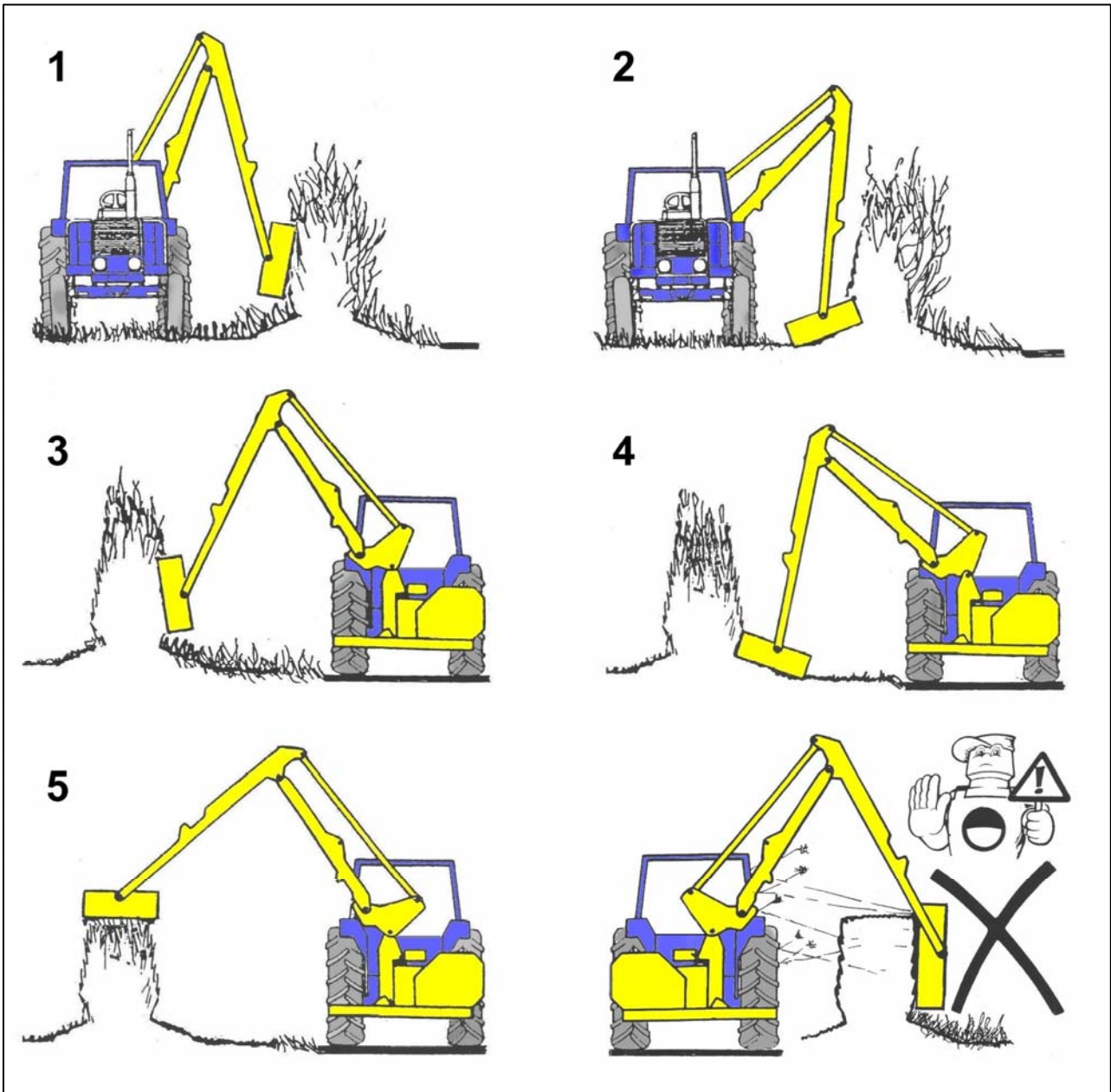

WARNING! Never cut on the blind side of the hedge; It is impossible to see potential hazards or dangers and the position of the flail head would possibly allow debris to be propelled through the hedge towards the tractor and the operator.

Wire Trap

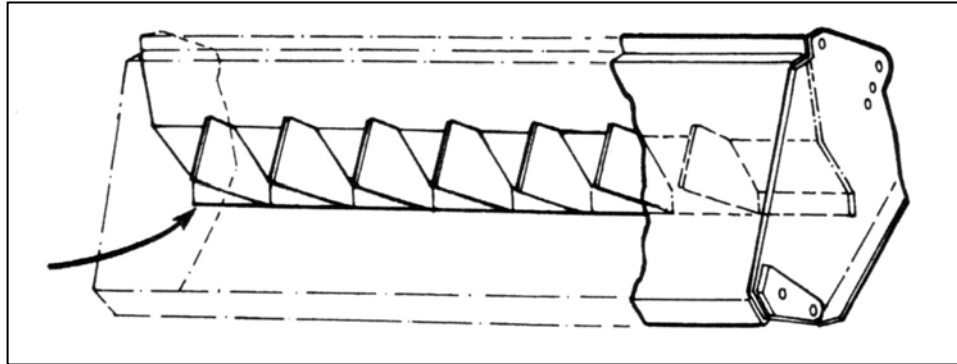

Flail hoods are equipped with a 'wire cutting edge' welded into the underside – this plate should not be interfered with or modified in any way. Any wire caught in the rotor must be removed immediately.

Removing Wire

Select rotor 'Off' and wait until it has **stopped rotating**.

Stop the tractor and pocket the key – **only then remove the wire**.

Do not reverse the rotor in an attempt to unwind any wire.

WARNING!

Ensure both tractor engine and machine are switched off and the rotor at a complete standstill before approaching the flail head.

OVERHEAD POWER LINES (OHPLs)

It cannot be stressed enough the dangers involved when working in the vicinity of Overhead Power Lines (OHPLs). Some of our machines are capable of reach in excess of 8 metres (26'); they have the potential to well exceed, by possibly 3 metres (9' 9"), the lowest legal minimum height of 5.2 metres from the ground for 11,000 and 33,000 volt power lines.

Remember electrocution can occur without actually coming into contact with a power line as electricity can 'flashover' when machinery gets close to it.



WARNING: All operators must read the following information and be aware of the risks and dangers involved when working in the vicinity of Overhead Power Lines (OHPLs).

Wherever possible the safest option is always to avoid working in areas close to OHPLs. Where unavoidable, all operators must perform a risk assessment and implement a safe procedure and system of work – see *following page for details*.

All operators should perform a risk assessment before operating the machine within 10m horizontal distance of any OHPLs.

Minimum Heights for Overhead Power Lines

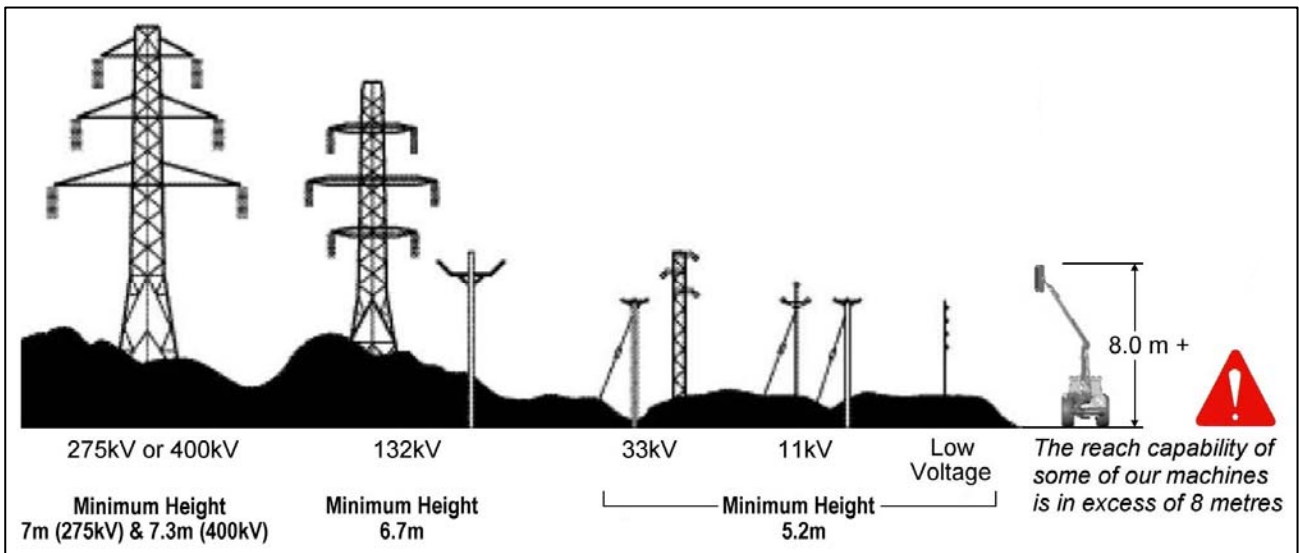

Absolute Minimum Exclusion Zones for Specific Overhead Power Lines

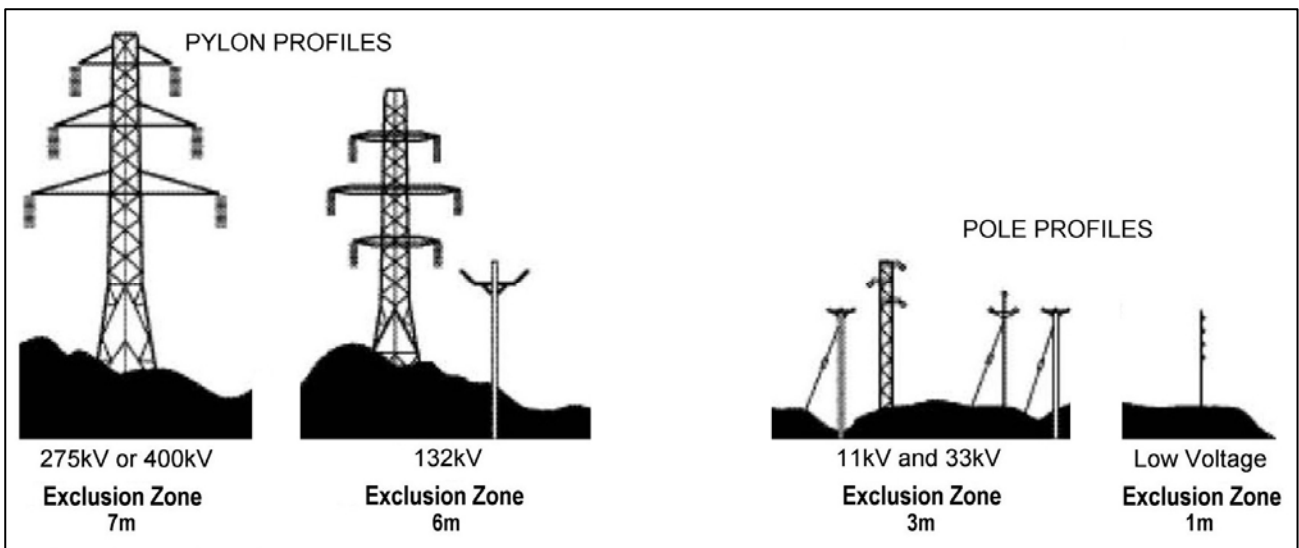

Definitions of Exclusion Zones

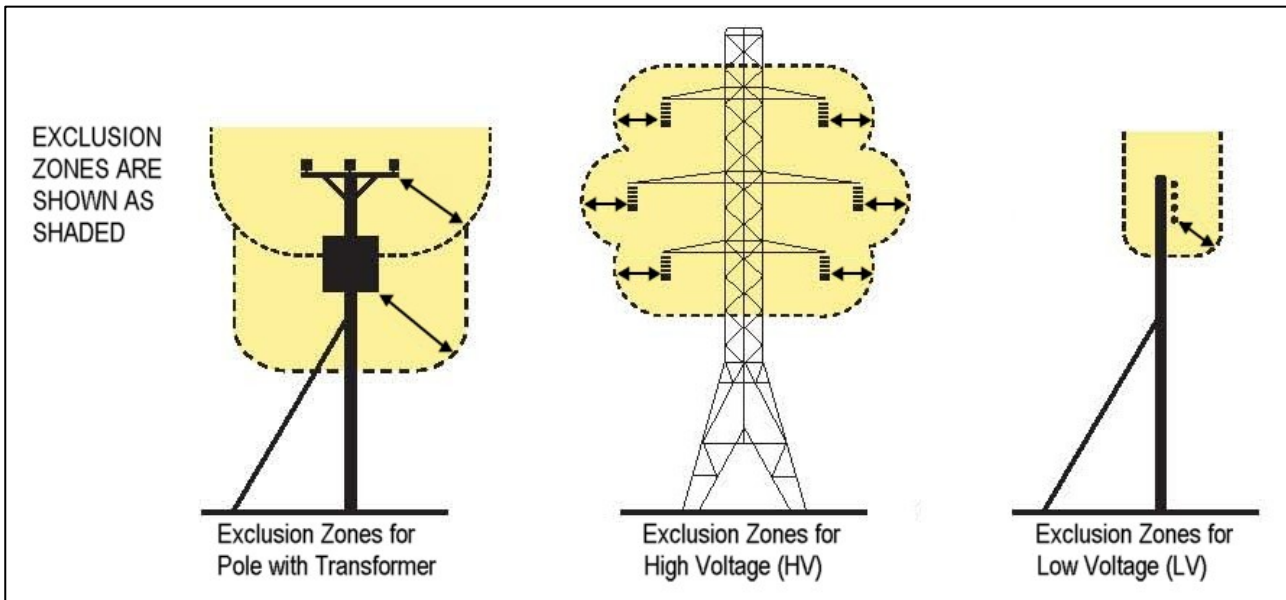

Risk Assessment

Before starting to work near OHPLs you should always assess the risks. The following points should be observed;

- **Know** the risks of contacting OHPLs and the risk of flashover.
- **Find out** the maximum height and maximum vertical reach of your machine.
- **Find out** the location and route of all Power Lines within the work area.
- **Find out** the operating voltage of all Power Lines within the work area.
- **Contact** the local Distribution Network Operator (DNO) who will be able to advise you on the operating voltage, safe minimum clearance distance for working, and additional precautions required.
- **Never** attempt to operate the machine in exclusion zones.
- **Always** work with extreme caution and plan your work ahead to avoid high risk areas.
- **If doubt exists** do not work in the area – never risk the safety of yourself or others.

Emergency Action for Accidents Involving Electricity

- Never touch an overhead line - even if it has been brought down by machinery, or has fallen. Never assume lines are dead.
- When a machine is in contact with an overhead line, electrocution is possible if anyone touches both the machine and the ground. Stay in the machine and lower any raised parts in contact or drive the machine out of the lines if you can.
- If you need to get out to summon help or because of fire, jump out as far as you can without touching any wires or the machine - keep upright and away.
- Get the electricity company to disconnect the supply. Even if the line appears dead, do not touch it - automatic switching may reconnect the power.

Further information and leaflets on this and other agricultural safety subjects are available on the 'Health & Safety Executive' website at the following address: www.hse.gov.uk/pubns/agindex.htm

Preliminary Precautions

Always inspect the work area beforehand and remove any hazardous objects or materials. Note the location of any immovable obstructions in order that they will be avoided whilst working the machine.

Rotor Cutting Direction

IMPORTANT: Flails must always cut upwards when the machine is being used for grass cutting work.

Upward Cutting

Front hood and rear flap must always be in position when upward cutting.

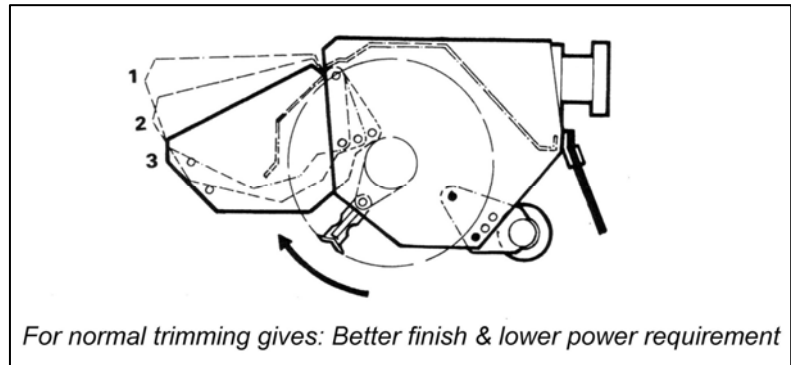

Downward Cutting

Rear hood must always be fitted when downward cutting.

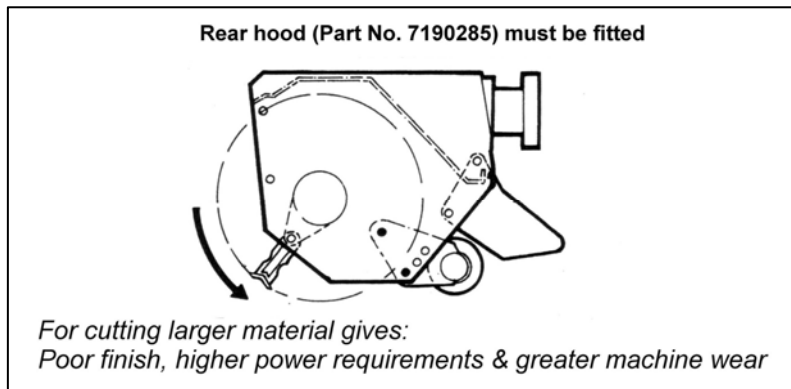

LIFT FLOAT KIT (Optional extra for ground cutting)

Lift Float Kits are available as an optional extra for use in ground cutting duties. The kit enables the flailhead to automatically follow the contours of the ground in the vertical plane, this is ideal for verge mowing as it greatly reduces the need for operator input.

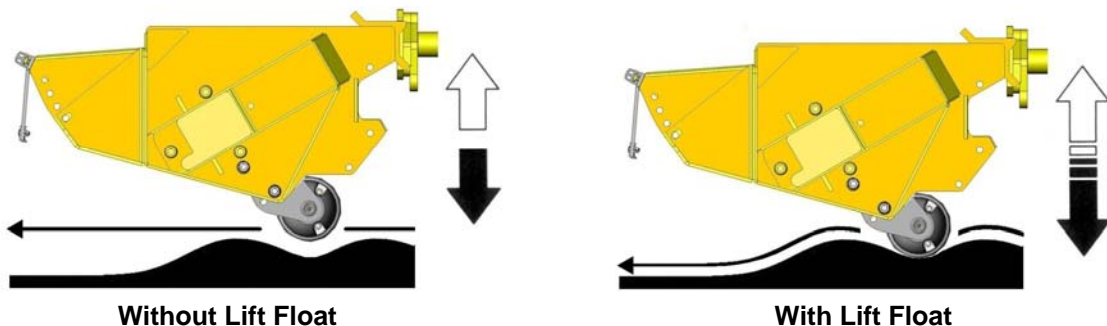

The kits can be supplied in either manual or electric versions, the part numbers for which are 8126326 & 8126327 respectively. Kits attach to the bulkhead on the rear of the mainframe as shown in the illustration below.

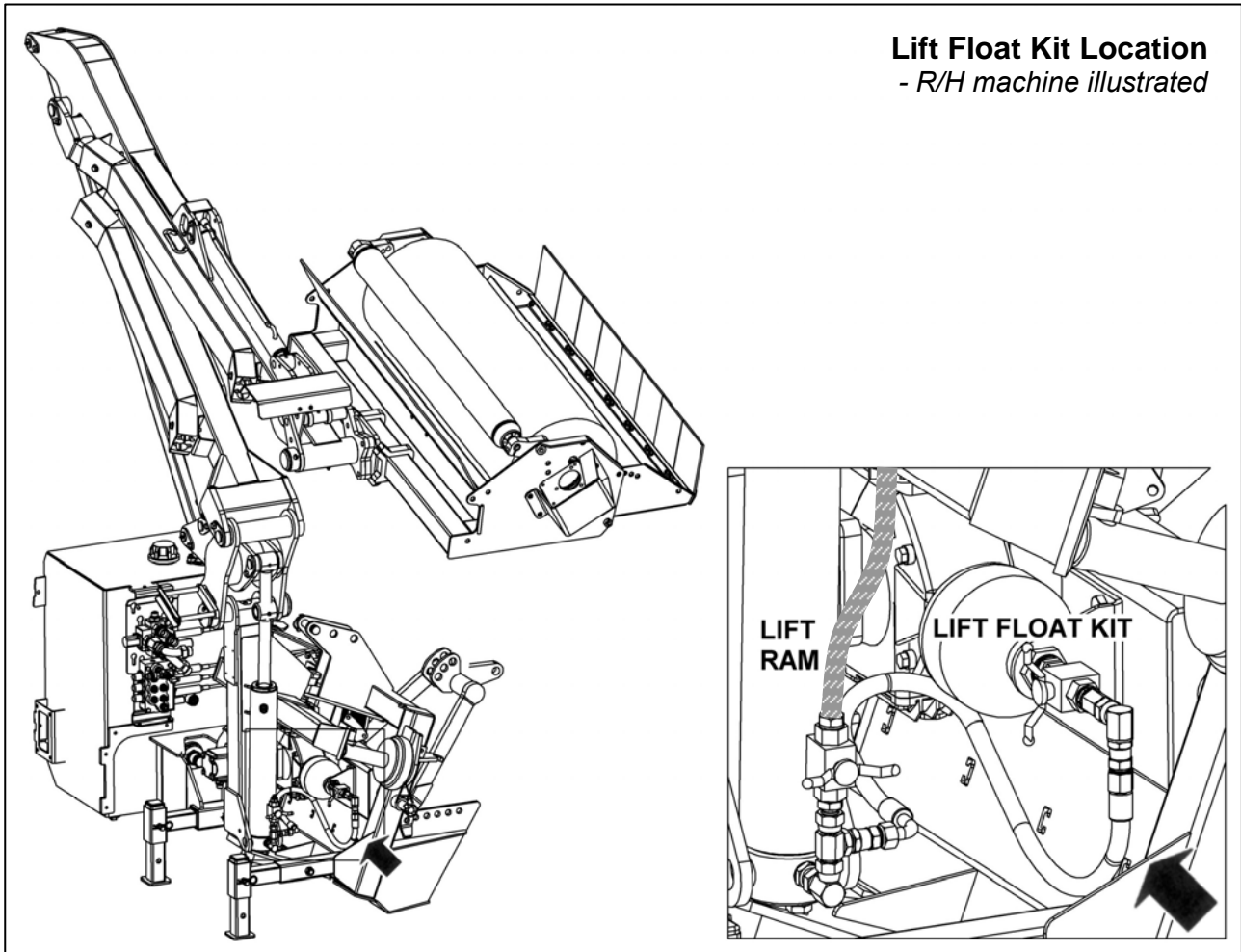

On electric controlled machines the cable from the poppet valve solenoid is connected to the lift float switch on the switchbox.

In work with the poppet valve open the flail head will automatically follow the ground contours.

The float function is engaged either by selection of the lift float switch on electric machines or by manually operating the 'manual override' on top of the poppet valve.

The lift control should be operated to take a proportion of the flail head weight off the flail roller. This is important, too little weight on the roller will leave uncut areas of grass while with too much weight on the roller the ground will be scalped in places and increased flail wear, damage, or even loss of flails could occur. To revert to standard operation the accumulator is isolated from the lift ram, by deselecting the float switch or by returning the manual override to the 'off' position.

On Multilever Electric machines where both lift float and angle float functions are fitted a switching kit (*part number 8402303*) is available which isolates the angle float. This allows the machine to be operated with either the lift and angle floats functioning together or with the lift float operating alone.

On Monolever Electric and Proportional machines the lift float can be operated alone or with lift and angle floats functioning together. The two-core cable is connected from the solenoid to wires 10 & 14 on the main harness.

FLOATING HEAD ANGLE FACILITY (*Optional Extra on Electric Machines*)

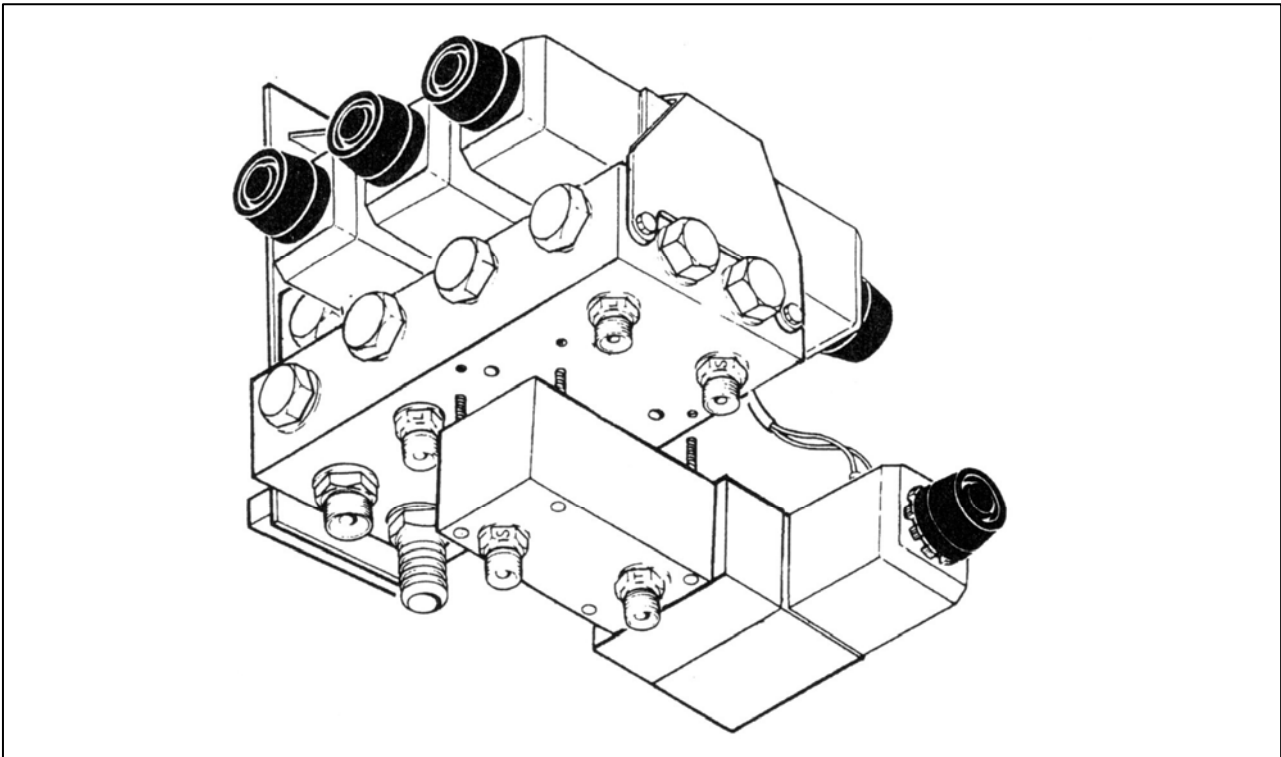

This facility will allow the flail head to angle itself automatically to suit the contours of the ground – selection of ‘angle float’ on the controls activates it.

The kit is bolted in position as shown in the diagram above. *Note; the ‘O’ rings from the hose plate must be extracted carefully and re-used.*

On Multilever Electric machines, the two-core cable is connected from the solenoid to the common link harness and connection 9 on the main harness.

On Monolever Electric and Proportional machines, the two-core cable is connected from the solenoid to wires 9 & 11 on the main harness.

VALVE CONNECTIONS

Armhead Control Valve Connections

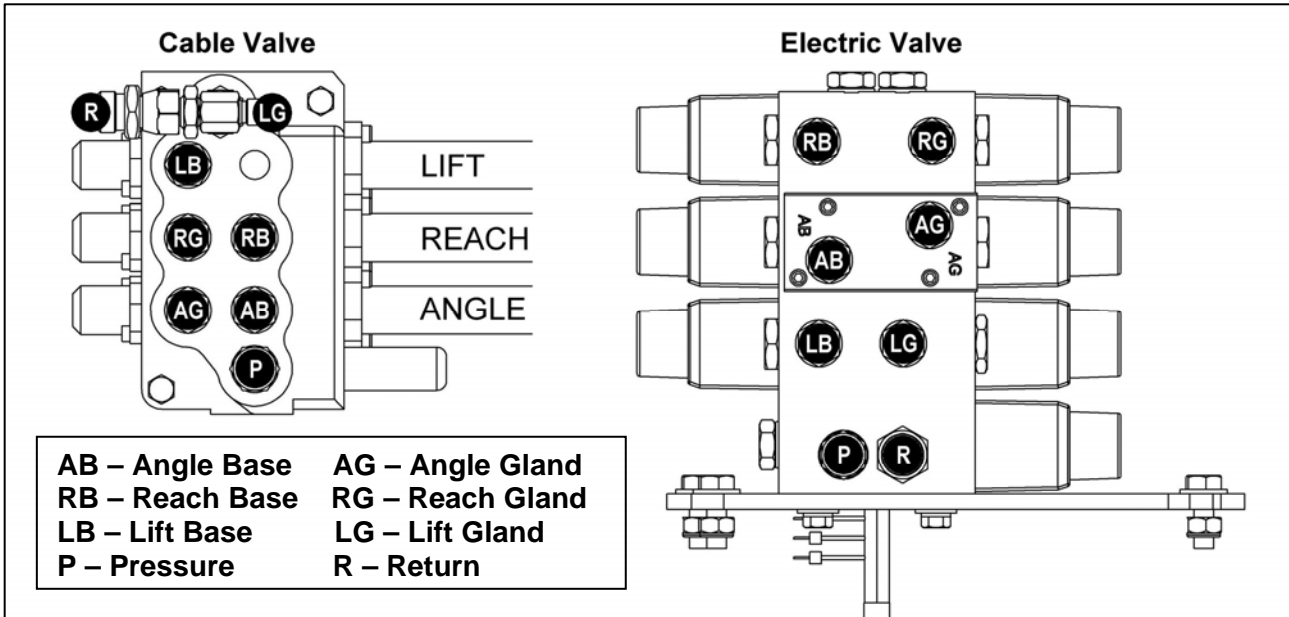

Rotor Valve Connections

SI Models

Rotor Relief Valve ▶

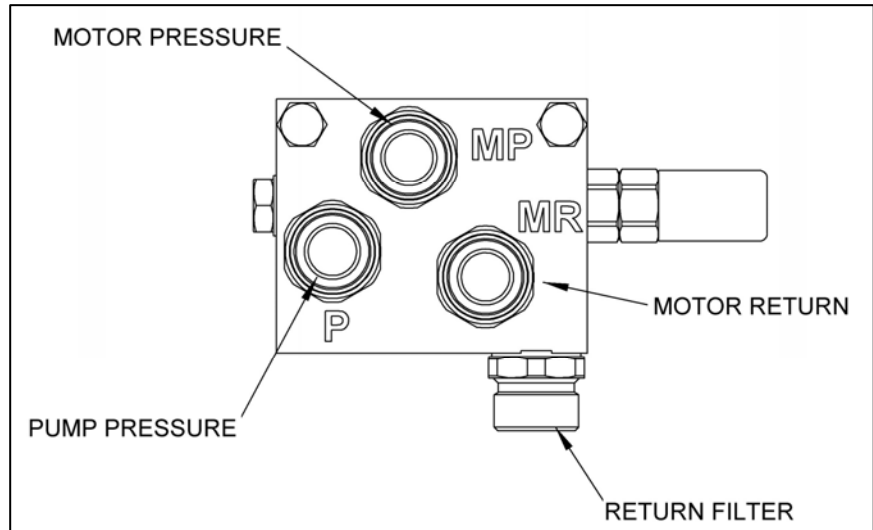

TI Models

Rotor Control Valve ▼

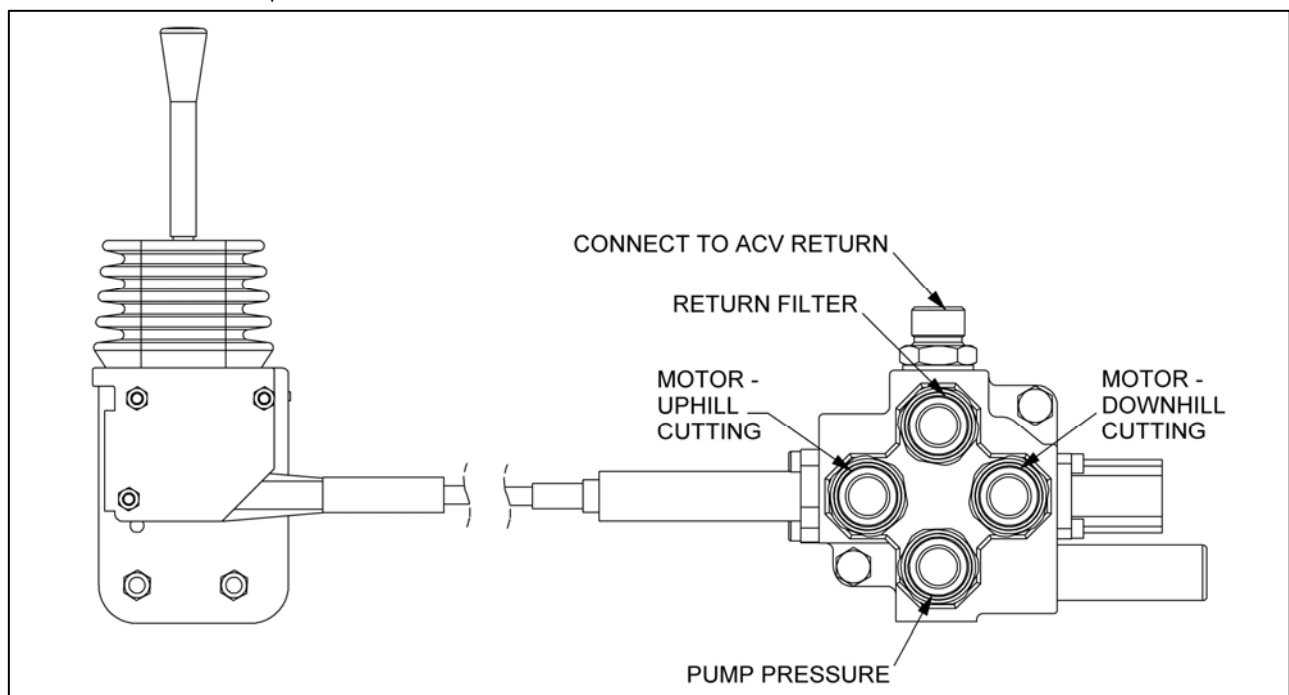

MAINTENANCE

General Lubrication

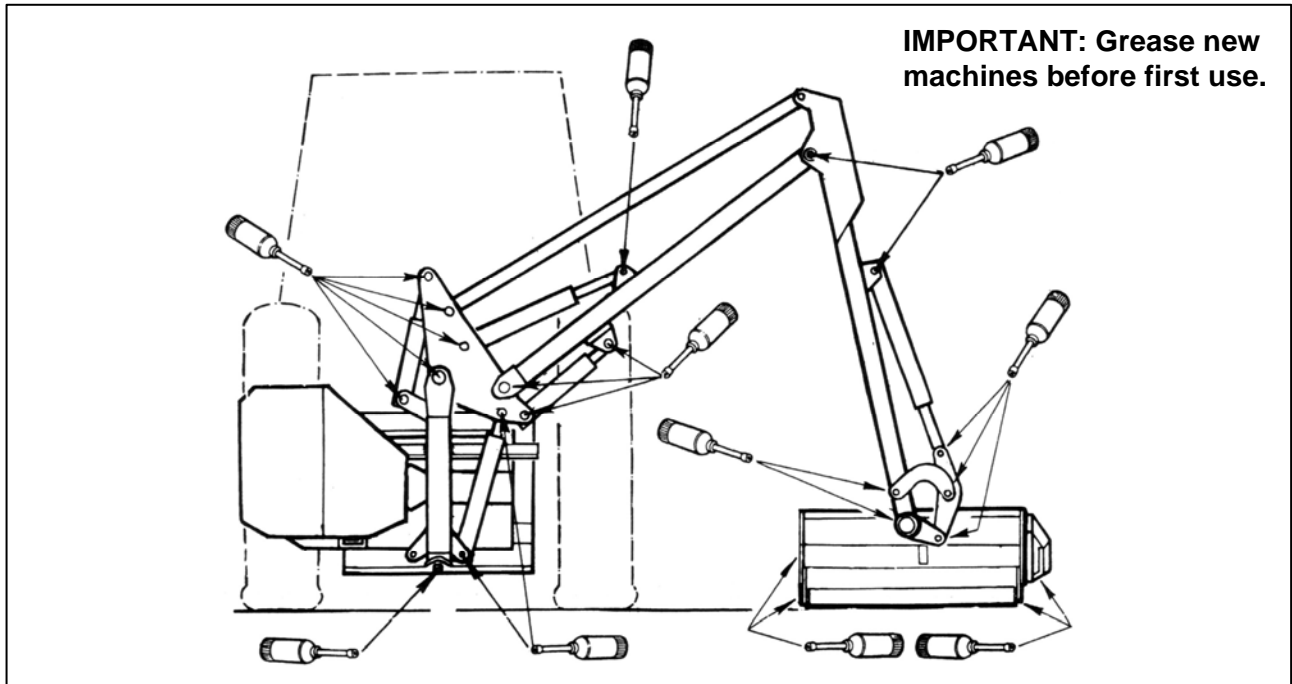

The lubrication points indicated above should be greased daily during work and prior to storage of the machine. New machines must be greased prior to first use.

Power Take-Off Shaft

The PTO Shaft and its guards should be regularly examined. The universal joints should be greased very sparingly i.e. one shot weekly.

Note: Over greasing a universal joint will 'blow-out' the cork or neoprene sealing rings that exclude the dirt from the needle bearings inside.

The two halves of the plastic guard should be checked daily to ensure that they can spin freely on the shaft. The nylon slip rings, which support the guard on the drive shaft, should be lightly greased at weekly intervals.

The telescopic drive shaft should be similarly separated and grease applied to the internal shaft at approximately 100 hour intervals.

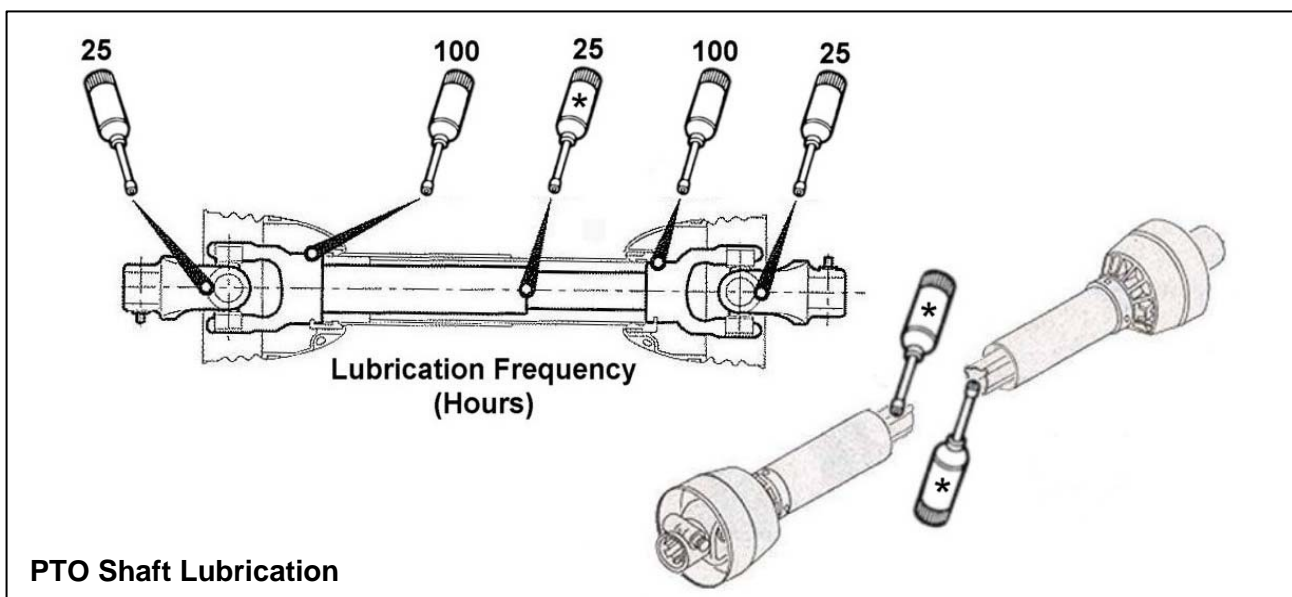

PTO Gearbox

Check gearbox oil level on new machines prior to first use, top up if required before using the machine. **Replace gearbox oil after an initial 50 hours of use** and thereafter at annual or 500 hour intervals; whichever occurs earliest.

Gearbox Capacity (Machines ► 11/13)

0.7 Litre SAE75W90 Fully Synthetic which meets the following minimum requirements;

Viscosity at 40°C, cSt, 100.0 min.

Viscosity at 100°C, cSt, 17.2 min.

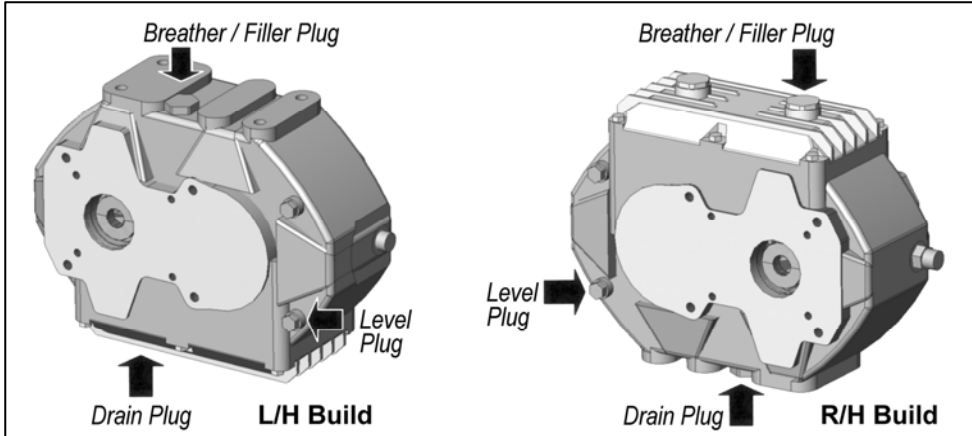
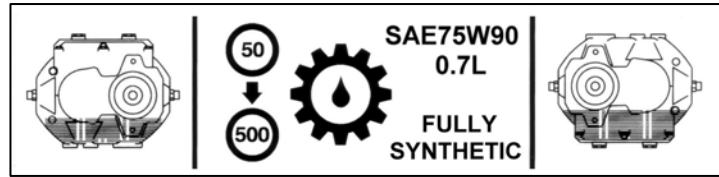

Drainage of the gearbox for an oil change is via the drain plug located on the base of the gearbox. To refill or for 'topping up' remove filler and level plugs indicated opposite and fill gearbox via the filler plug to a point where the oil starts to run from the level plug orifice. Replace both plugs and tighten.

Gearbox Capacity (Machines 11/13 ►)

0.6 Litre SAE75W90 Fully Synthetic which meets the following minimum requirements;

Viscosity at 40°C, cSt, 100.0 min.

Viscosity at 100°C, cSt, 17.2 min.

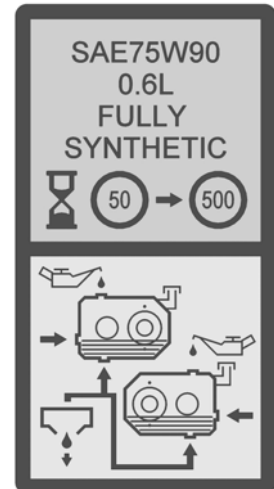
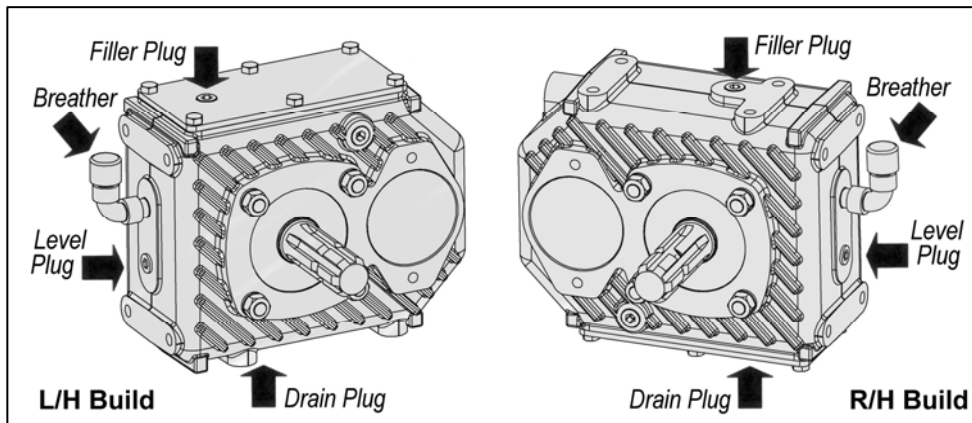

SERVICE SCHEDULE

Every Day

- Grease machine fully prior to work (and prior to storage).
NOTE: New machines must be greased before initial use.
- Check for broken or damaged flails.
- Check tightness of flail nuts and bolts.
- Visually check for oil leaks and damaged hoses.
- Check all guards and safety shields are correctly fitted and undamaged.
- Ensure all lights are working and clean.
- Check oil level.
- Clean the cooler matrix, in dusty conditions more frequent cleaning is required.

After initial 12 Hours

- Change return line filter element. *Failure to do so will invalidate the warranty.*
Note; factory fitted filter elements are identified differently to replacement elements.

After initial 50 Hours

- Change gearbox oil.

Every 25 Hours

- Grease PTO Shaft universal joints and tubes.

Every Week

- Check tightness of all nuts and bolts.
- Check gearbox oil level.
- Check for wear on telescopic arm pads – *where applicable.*

Every 100 Hours

- Grease PTO shaft shield lubrication points.

Every 500 Hours

- Change return line filter element.
- Change gearbox oil.
- Check condition of hydraulic oil and change if required; *when changing oil new return line filter and suction strainer elements should be fitted and return line filter changed again after 12 hours of work.*

Annually

- Change tank breather.

HYDRAULIC SYSTEM

Oil Supply

Check the oil level in the reservoir daily.

Oil Condition & Replacement

No fixed time period can be quoted for oil changes as operating conditions can vary widely but a visually inspection of the oil will often indicate its current overall state. Signs of a reduction in its condition will be apparent by changes in colour and appearance when compared to new oil. Oil in poor condition can be dark, smell rancid or burnt, or in some cases be yellow, unclear or milky in appearance indicating the presence of air or emulsified water. Moisture resulting from condensation can become entrapped in the oil causing emulsification that can block the return line filter, consequentially the filter system will be by-passed and the oil and any possible contaminants present will continue to circulate without filtration risking damage to hydraulic components. All are indications or conditions that will require replacement of the oil.

Hydraulic oil is a vital component of the machine; contaminated oil is the root cause of 70% of all hydraulic system failures. Contamination can be reduced by the following:

- Cleaning around the reservoir cap before removal, and keeping the tank area clean.
- Use of clean containers when replenishing the system.
- Regular servicing of the filtration system.

Filtration System

Machines are protected by both replaceable 125 micron suction strainers and low pressure 25 micron full flow return line filters – the diagram below is a ‘scaled up’ view illustrating the filtering capability built into the hydraulic system of the machine:

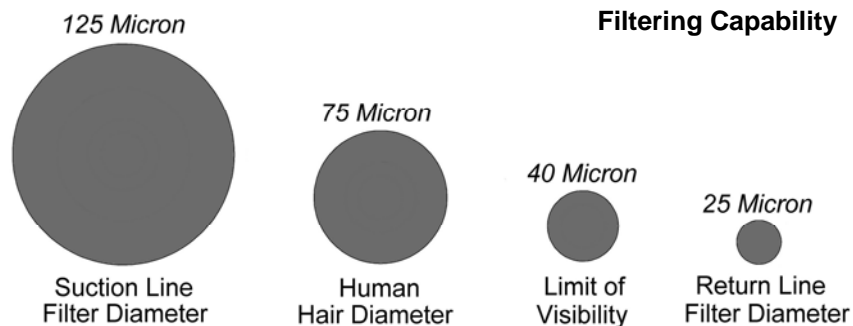

Suction strainers

The replaceable 125 micron suction strainers (*Part No. 8401097*) are fitted within the hydraulic tank and are ‘screw’ fitted with easy access for removal and replacement.

Return Line Filter

The 25 micron absolute filter elements (*Part No. 8401089*) should be changed after the first 12 hours and thereafter at 500-hour intervals. It is important to note hours worked as if the filter becomes blocked an internal by-pass within the canister will operate and no symptoms of filter malfunction will occur to jog your memory.

Tank Breather

To reduce the risk of pump cavitation it is advisable to replace the 25 micron absolute tank breather (*Part No. 8401050*) on an annual basis under normal working conditions – for machines operating in dry dusty environments it is recommended that replacement be increased to 6 monthly.

HYDRAULIC HOSES

The condition of all hoses should be carefully checked during routine service of the machine. Hoses that have been chaffed or damaged on their outer casing should be securely wrapped with waterproof adhesive tape to stop the metal braid from rusting. Hoses that have suffered damage to the metal braid should be changed at the earliest opportunity.

Hose Replacement

Before changing any hoses take the time to study the existing installation as the routing has been carefully calculated to prevent hose damage during operation - always replace hoses in exactly the same location and manner. This is especially important for the flail hoses where they must be crossed, upper to lower, at the dipper and head pivots.

- Always replace one hose at a time to avoid the risk of wrong connections.
- When the hose is screwed to an additional fitting or union, use a second spanner on the union to avoid breaking both seals.
- Do not use jointing compound on the threads.
- Avoid twisting the hose. Adjust the hose line to ensure freedom from rubbing or trapping before tightening hose end connections.

All Hydraulic Hoses (BSP) now fitted to McConnel Power Arm Hedge/Grass Cutters have 'soft seal' connections on both flail and ram circuit hoses.

Recommended torque settings for nut security are as follows:

SIZE		TORQUE SETTING			O Ring Ref.
1/4" BSP	=	24 Nm	or	18 lb.ft.	10 000 01
3/8" BSP	=	33 Nm	or	24 lb.ft.	10 000 02
1/2" BSP	=	44 Nm	or	35 lb.ft.	10 000 03
5/8" BSP	=	58 Nm	or	43 lb.ft.	10 000 04
3/4" BSP	=	84 Nm	or	62 lb.ft.	10 000 05
1" BSP	=	115 Nm	or	85 lb.ft.	10 000 06

For hose unions (BSP) fitted in conjunction with bonded seals the recommended torque settings are as follows:

SIZE		TORQUE SETTING		
1/4" BSP	=	34 Nm	or	25 lb.ft.
3/8" BSP	=	75 Nm	or	55 lb.ft.
1/2" BSP	=	102 Nm	or	75 lb.ft.
5/8" BSP	=	122 Nm	or	90 lb.ft.
3/4" BSP	=	183 Nm	or	135 lb.ft.
1" BSP	=	203 Nm	or	150 lb.ft.

Safety Note

Soft seal hose connections are capable of holding pressure when the nut is only 'finger tight'. It is therefore recommended during dismantling that the hose be manually flexed to relieve any residual pressure with the retaining nut slackened prior to complete disassembly.

CONTROL CABLES

The control cables operate on a push/pull system with the spool centring springs always returning the spool to the neutral position when the handle is released.

Care should be taken during installation and operation to ensure that the cables are not trapped or kinked. Any abrasion or damage to the outer casing should be sealed with plastic insulation tape to avoid moisture penetrating.

No routine adjustments of the cables are necessary, as they do not stretch. The threaded collar is correctly adjusted when the lever is in a vertical position in its housing allowing an equal amount of travel in either direction.

CAUTION!

On no account should any attempt be made to lubricate the cables – these are assembled with a special ‘lifelong’ lubricant during manufacture and will not require any additional lubrication.

Note: Take care to ascertain the correct cable connections on both the control unit and the valve in the event of cable replacement.

FLAIL HEAD

Frequently inspect the rotor assembly for damaged or missing flails. Bolts and nuts securing the flails to the rotor should be regularly checked and kept tight. The correct torque setting for these locknuts is 135Nm (*100 lbf/ft.*). Use only the correct flail bolt and locking nut. Check the flail pivot bushes for possible damage or wear - they do not require oil.

Do not attempt to run the rotor with flails missing. Imbalance will cause severe vibration and can rapidly damage the rotor shaft bearings. As an emergency measure if a flail is broken off or lost, remove another on the opposite side of the rotor to retain balance. Always replace flails in opposite pairs and never match up a new flail with a re-sharpened one, which will of course be lighter.

Blunt flails absorb a lot of power and leave an untidy finish to the work. They should be sharpened on a grindstone or with a portable grinder periodically.

WARNING!

Wear protective gear when sharpening flails.

Ensure that the bearing housings and hydraulic mounting nuts and bolts are kept tight. They should be checked during servicing.

PTO SHAFT MAINTENANCE

PTO Shaft Lubrication

The PTO shaft should be lubricated on a regular basis using lithium based grease – each end of the shaft has 2 greasing points; one for lubrication of the universal joint and one for lubricating the rotating fixing ring of the shaft shield – access to the lubrication points is gained by releasing the shaft shield from its fixing ring and sliding it back along the body of the driveshaft – *the procedure and lubrication frequency is illustrated below.*



Shaft shield fixing clasps



Insert screwdrivers into the clasps



Prise clasps open to release the shield



Slide shield back to reveal universal joint

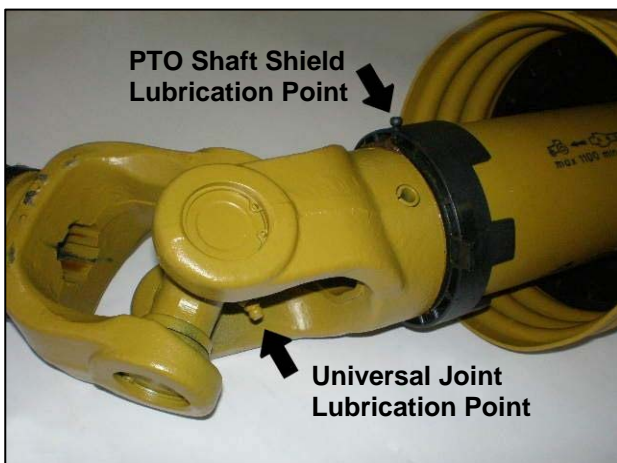

Location of lubrication points



Recommended lubricating frequency

Slide the shaft shield back into place after lubrication ensuring the clasps relocate correctly in the fixing ring – always fit torque chains to the shields to stop them from rotating with the shaft during operation.

TORQUE SETTINGS FOR FASTENERS

The chart below lists the correct tightening torque for fasteners. This chart should be referred to when tightening or replacing bolts in order to determine the grade of bolt and the correct torque unless specific torque values are assigned in the text of the manual.

Recommended torque is quoted in Foot-Pounds and Newton-Metres within this manual. The equation for conversion is 1 Nm. = 0.7376 ft.lbs.

TORQUE VALUES FOR IMPERIAL BOLTS

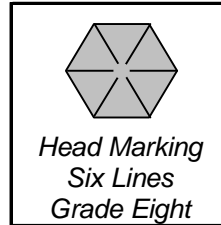
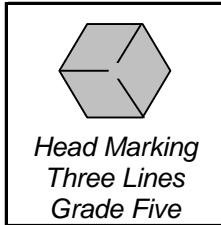
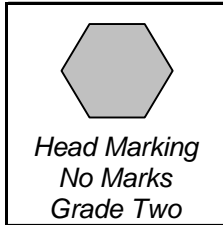

NOTE:
The values in the chart apply to fasteners as received from the supplier, dry or when lubricated with normal engine oil. They DO NOT apply if special graphited, molydisulphide greases, or other extreme pressure lubricants are used. This applies to both UNF and UNC coarse threads.

Bolt Dia.
1/4"
5/16"
3/8"
7/16"
1/2"
9/16"
5/8"
3/4"
7/8"
1"
1-1/8"
1-1/4"
1-3/8"
1-1/2"

Value (Dry)	
ft.lb.	Nm.
5.5	7.5
11	15.0
20	27.0
32	43.0
50	68.0
70	95.0
100	135.0
175	240.0
175	240.0
270	360.0
375	510.0
530	720.0
700	950.0
930	1250.0

Value (Dry)	
ft.lb.	Nm.
9	12.2
18	25.0
33	45.0
52	70.0
80	110.0
115	155.0
160	220.0
280	380.0
450	610.0
675	915.0
850	115.0
1200	1626.0
1550	2100.0
2100	2850.0

Value (Dry)	
ft.lb.	Nm.
12.5	17.0
26	35.2
46	63.0
75	100.0
115	155.0
160	220.0
225	305.0
400	540.0
650	880.0
975	1325.0
1350	1830.0
1950	2650.0
2550	3460.0
3350	4550.0

TORQUE VALUES FOR METRIC BOLTS.

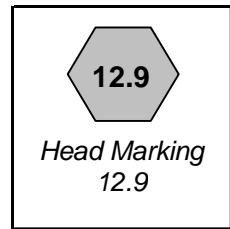
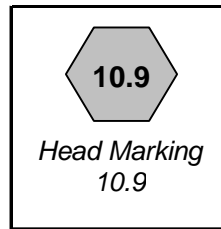
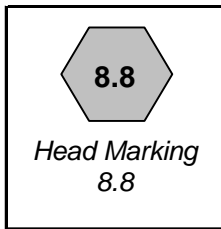
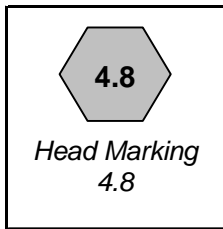

Bolt Dia.
6mm
8mm
10mm
12mm
14mm
16mm
18mm
20mm
22mm
24mm
27mm
30mm

Value (Dry)	
ft.lb.	Nm.
4.5	6.1
11	14.9
21	28.5
37	50.2
60	81.4
92	125.0
125	170.0
180	245.0
250	340.0
310	420.0
450	610.0
625	850.0

Value (Dry)	
ft.lb.	Nm.
8.5	11.5
20	27.1
40	54.2
70	95.0
110	150.0
175	240.0
250	340.0
350	475.0
475	645.0
600	810.0
875	1180.0
1200	1626.0

Value (Dry)	
ft.lb.	Nm.
12	16.3
30	40.1
60	81.4
105	140.0
165	225.0
255	350.0
350	475.0
500	675.0
675	915.0
850	1150.0
1250	1700.0
1700	2300.0

Value (Dry)	
ft.lb.	Nm.
14.5	20.0
35	47.5
70	95.0
120	160.0
190	260.0
300	400.0
410	550.0
580	790.0
800	1090.0
1000	1350.0
1500	2000.0
2000	2700.0

DEBRIS BLOWER KIT (*Optional Extra*)

The Debris Blower is a hydraulically powered, mechanically adjustable, 'blower' unit for the clearance of hedge or grass cuttings from the highway during work with the machine. The Debris Blower unit is attached to the machine by means of a bracket assembly fitted to the base of the machines hydraulic tank onto which the Debris Blower is then bolted.

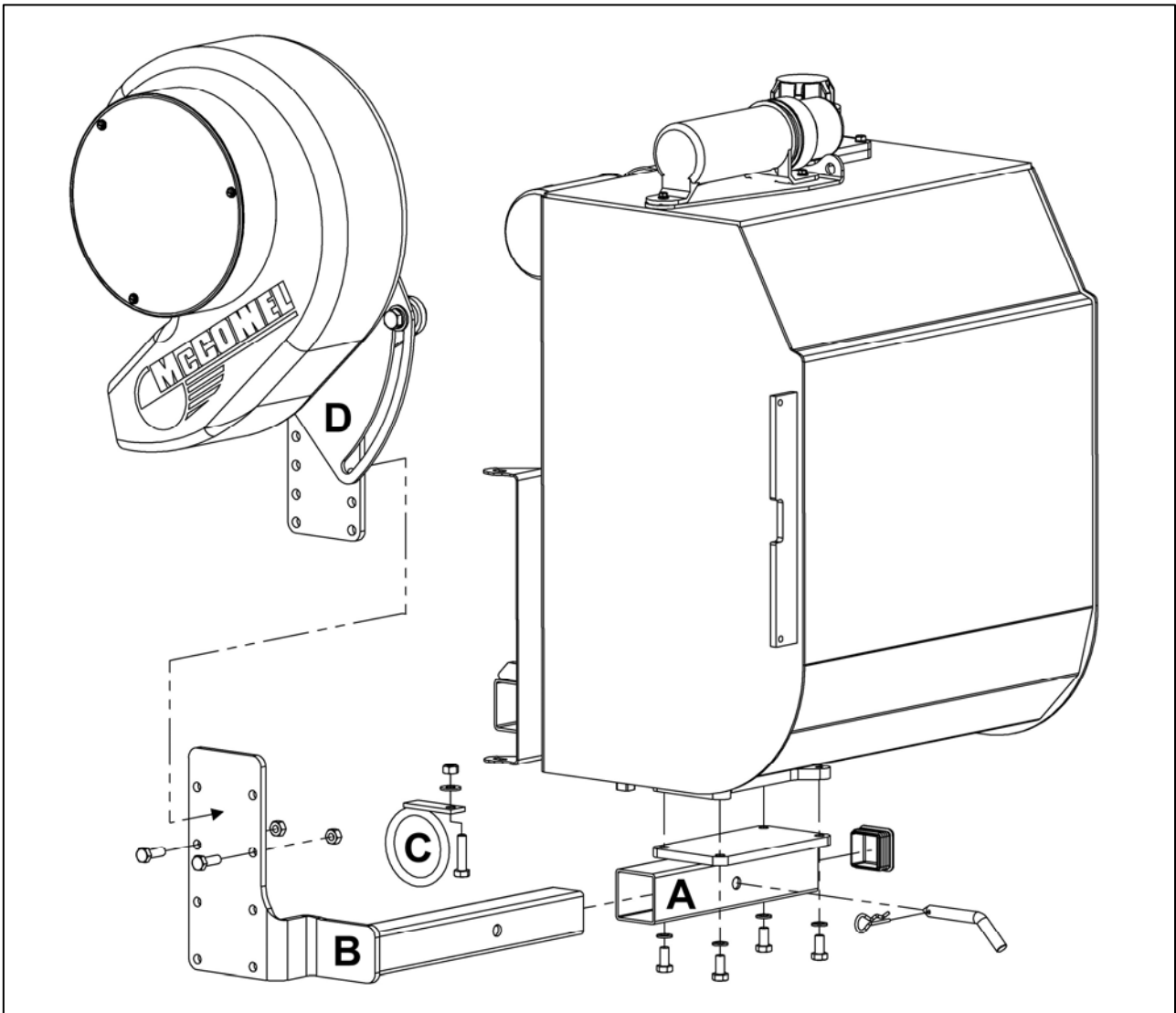

Debris Blower Bracket Fitting

Attach fixed bracket 'A' to the weldment provided on the base of the hydraulic tank and secure tightly in position with the bolts and washers supplied in the kit. Slide support bracket 'B' into bracket 'A' until the holes in each correspond – lock in position with pin and clip supplied. Hose ring 'C' should be attached to a suitable available location in order to support the hydraulic hoses and prevent them from coming into contact with the ground or fouling on any components or obstructions – *in some cases the hose ring and its bolt can be attached to the fixed bracket in place of one of those bolts providing that allows for suitable routing of the hydraulic hoses.*

The Debris Blower Unit is then bolted in place on the back of support bracket 'B' – refer to *Instruction Supplement 227 (Part No. 41486.28)* supplied with the Debris Blower for details of attaching the unit and connection of the hydraulic hoses.

NOTE: Debris Blower fixing brackets may vary between machine models, left hand & right hand machines, and for machines with a rear light bar fitted.



McConnel Limited, Temeside Works, Ludlow, Shropshire SY8 1JL. England.
Telephone: 01584 873131. Facsimile: 01584 876463. www.mcconnel.com