

# PA 470

## Operator manual

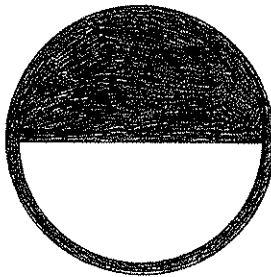
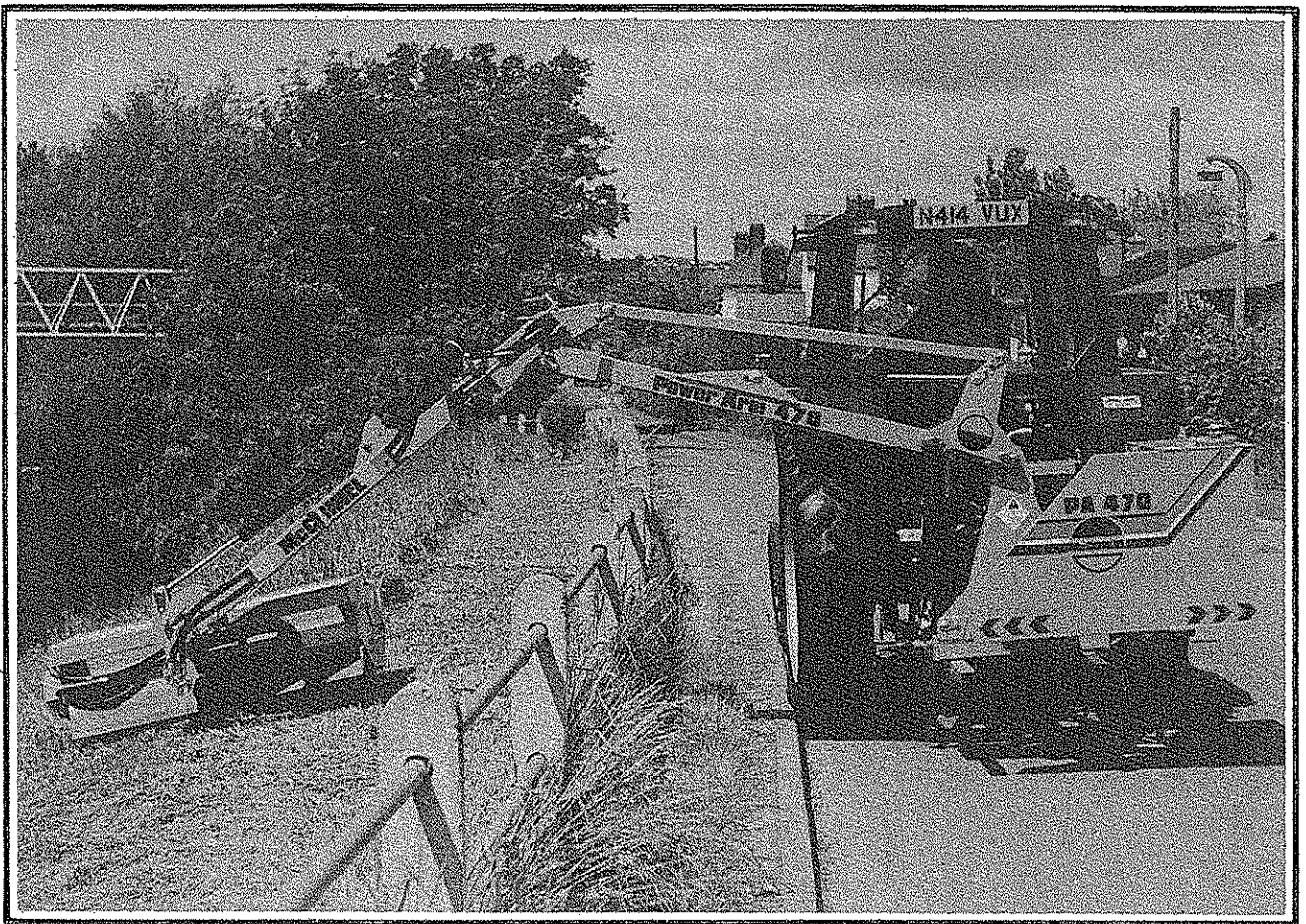

# IMPORTANT

## VERIFICATION OF WARRANTY REGISTRATION



### DEALER WARRANTY INFORMATION & REGISTRATION VERIFICATION

It is imperative that the selling dealer registers this machine with McConnel Limited before delivery to the end user – failure to do so may affect the validity of the machine warranty.

To register machines go to the McConnel Limited web site at [www.mcconnel.com](http://www.mcconnel.com), log onto 'Dealer Inside' and select the 'Machine Registration button' which can be found in the Service Section of the site. Confirm to the customer that the machine has been registered in the section below.

Should you experience any problems registering a machine in this manner please contact the McConnel Service Department on 01584 875848.

### Registration Verification

Dealer Name: .....
Dealer Address: .....
Customer Name: .....
Date of Warranty Registration: ...../...../..... Dealer Signature: .....

### NOTE TO CUSTOMER / OWNER

*Please ensure that the above section above has been completed and signed by the selling dealer to verify that your machine has been registered with McConnel Limited.*

**IMPORTANT:** During the initial 'bedding in' period of a new machine it is the customer's responsibility to regularly inspect all nuts, bolts and hose connections for tightness and re-tighten if required. New hydraulic connections occasionally weep small amounts of oil as the seals and joints settle in – where this occurs it can be cured by re-tightening the connection – *refer to torque settings chart below*. The tasks stated above should be performed on an hourly basis during the first day of work and at least daily thereafter as part of the machines general maintenance procedure.

### TORQUE SETTINGS FOR HYDRAULIC FITTINGS

HYDRAULIC HOSE ENDS		
BSP	Setting	Metric
1/4"	18 Nm	19 mm
3/8"	31 Nm	22 mm
1/2"	49 Nm	27 mm
5/8"	60 Nm	30 mm
3/4"	80 Nm	32 mm
1"	125 Nm	41 mm
1.1/4"	190 Nm	50 mm
1.1/2"	250 Nm	55 mm
2"	420 Nm	70 mm

PORT ADAPTORS WITH BONDED SEALS		
BSP	Setting	Metric
1/4"	34 Nm	19 mm
3/8"	47 Nm	22 mm
1/2"	102 Nm	27 mm
5/8"	122 Nm	30 mm
3/4"	149 Nm	32 mm
1"	203 Nm	41 mm
1.1/4"	305 Nm	50 mm
1.1/2"	305 Nm	55 mm
2"	400 Nm	70 mm

# WARRANTY POLICY

## WARRANTY REGISTRATION

All machines must be registered, by the selling dealer with McConnell Ltd, before delivery to the end user. On receipt of the goods it is the buyer's responsibility to check that the Verification of Warranty Registration in the Operator's Manual has been completed by the selling dealer.

### 1. LIMITED WARRANTIES

- 1.01. All machines supplied by McConnell Limited are warranted to be free from defects in material and workmanship from the date of sale to the original purchaser for a period of 12 months, unless a different period is specified.
- 1.02. All spare parts supplied by McConnell Limited are warranted to be free from defects in material and workmanship from the date of sale to the original purchaser for a period of 6 months.
- 1.03. The manufacturer will replace or repair for the purchaser any part or parts found, upon examination at its factory, to be defective under normal use and service due to defects in material or workmanship. Returned parts must be complete and unexamined.
- 1.04. This warranty does not apply to any part of the goods, which has been subjected to improper or abnormal use, negligence, alteration, modification, fitment of non-genuine parts, accident damage, or damage resulting from contact with overhead power lines, damage caused by foreign objects (e.g. stones, iron, material other than vegetation), failure due to lack of maintenance, use of incorrect oil or lubricants, contamination of the oil, or which has served its normal life. This warranty does not apply to any expendable items such as blades, flails, flap kits, skids, soil engaging parts, shields, guards, wear pads or pneumatic tyres.
- 1.05. Temporary repairs and consequential loss - i.e. oil, downtime and associated parts are specifically excluded from the warranty.
- 1.06. Warranty on hoses is limited to 12 months and does not include hoses which have suffered external damage. Only complete hoses may be returned under warranty, any which have been cut or repaired will be rejected.
- 1.07. Machines must be repaired immediately a problem arises. Continued use of the machine after a problem has occurred can result in further component failures, for which McConnell Ltd cannot be held liable, and may have safety implications.
- 1.08. Except as provided herein, no employee, agent, dealer or other person is authorised to give any warranties of any nature on behalf of McConnell Ltd.
- 1.09. For machine warranty periods in excess of 12 months the following additional exclusions shall apply:
  - 1) Hoses, external seals, exposed pipes and hydraulic tank breathers.
  - 2) Filters.
  - 3) Rubber mountings.
  - 4) External electric wiring.

**N.B. Warranty cover will be invalid if any non-genuine parts have been fitted or used. Use of non-genuine parts may seriously affect the machine's performance and safety. McConnell Ltd. cannot be held responsible for any failures or safety implications that arise due to the use of non-genuine parts.**

## **2. REMEDIES AND PROCEDURES**

- 2.01. The warranty is not effective unless the Selling Dealer registers the machine, via the McConnel web site and confirms the registration to the purchaser by completing the Verification of Warranty Registration in the operator's manual.
- 2.02. Any fault must be reported to an authorised McConnel dealer as soon as it occurs. Continued use of a machine, after a fault has occurred, can result in further component failure for which McConnel Ltd cannot be held liable.
- 2.03. Repairs should be undertaken within two days of the failure. Claims submitted for repairs undertaken more than 2 weeks after a failure has occurred, or 2 days after the parts were supplied will be rejected, unless the delay has been authorised by McConnel Ltd.
- 2.04. All claims must be submitted, by an authorised McConnel Service Dealer, within 30 days of the date of repair.
- 2.05. Following examination of the claim and parts the manufacture will pay, at their discretion, for any valid claim the cost of any parts and an appropriate labour allowance if applicable.
- 2.06. The submission of a claim is not a guarantee of payment.
- 2.07. Any decision reached by McConnel Ltd. is final.

## **3. LIMITATION OF LIABILITY**

- 3.01. The manufacturer disclaims any express (except as set forth herein) and implied warranties with respect to the goods including, but not limited to, merchantability and fitness for a particular purpose.
- 3.02. The manufacturer makes no warranty as to the design, capability, capacity or suitability for use of the goods.
- 3.03. Except as provided herein, the manufacturer shall have no liability or responsibility to the purchaser or any other person or entity with respect to any liability, loss, or damage caused or alleged to be caused directly or indirectly by the goods including, but not limited to, any indirect, special, consequential, or incidental damages resulting from the use or operation of the goods or any breach of this warranty. Notwithstanding the above limitations and warranties, the manufacturer's liability hereunder for damages incurred by the purchaser or others shall not exceed the price of the goods.
- 3.04. No action arising out of any claimed breach of this warranty or transactions under this warranty may be brought more than one (1) year after the cause of the action has occurred.

## **4. MISCELLANEOUS**

- 4.01. The manufacturer may waive compliance with any of the terms of this limited warranty, but no waiver of any terms shall be deemed to be a waiver of any other term.
- 4.02. If any provision of this limited warranty shall violate any applicable law and is held to be unenforceable, then the invalidity of such provision shall not invalidate any other provisions herein.
- 4.03. Applicable law may provide rights and benefits to the purchaser in addition to those provided herein.



# EC DECLARATION OF CONFORMITY

*Conforming to EEC Machinery Directive 98/37/EC\**

We,

**McCONNEL LIMITED,**

Temeside Works, Ludlow, Shropshire SY8 1JL.

*Declare under our sole responsibility that:*

The product (type) Tractor Mounted Arm Flail Mower.....

Product Code PA47.....

Serial No. & Date ..... Type .....

Manufactured by the above company/\* .....

*(\* insert business name and full address if not stated above)*

Complies with the required provisions of the Machinery Directive 98/37/EC, \* previously Directive 89/392/EEC as amended by Directives 91/368/EEC, 93/44/EEC and 93/68/EEC.

The machinery directive is supported by;

- BS EN ISO 12100:2003 Safety of Machinery. This standard is made up of two parts; Part 1 Terminology, methodology, Part 2 Technical Specifications.
- BS EN 1050 Safety of machinery - Principles of risk assessment.
- and other national standards associated with its design and construction as listed in the Technical File.

The Machinery Directive is fully implemented into UK law by means of the Supply of Machinery (Safety) Regulations 1992 (SI 1992/3073) as amended by The Supply of Machinery (Safety) (Amendment) Regulations 1994 (SI 1994/2063).

Signed John Frank.....

*on behalf of McCONNEL LIMITED*

*Responsible Person*

Status: Chief Design Engineer

Date: 25<sup>th</sup> January 2005

## **READ THE BOOK FIRST**

**It might save hours and pounds later**

**When ordering spare parts always  
quote the machine type and serial  
number as well as the part number**

**Factory re-built service exchange  
units of the major hydraulic components  
are available from you dealer.**

## **NOISE**

The equivalent daily personal noise exposure from this machine, measured at the operators' ear, is within the range 78 - 85 DB.

These figures apply to a normal distribution of use where noise fluctuates between zero and maximum. The figures assume that the machine is fitted to a tractor with a quiet cab with the windows closed in a generally open environment. We recommend that the windows are kept closed.

With the cab rear window open the equivalent daily personal noise exposure will increase to a figure within the range 82-88 DB.

At equivalent daily noise exposure levels of between 85 and 90 DB, ear protection is recommended, it should be used if any window is left open.

**FOR NOTES**



## LIST OF CONTENTS

GENERAL INFORMATION .....	Page 1
FEATURES .....	Page 2
SAFETY PRECAUTIONS .....	Page 3
FITTING .....	Page 7
Minimum tractor weight .....	Page 7
Minimum h.p. requirements .....	Page 7
Linkage .....	Page 7
P.T.O. Shaft .....	Page 7
Linkage isolation .....	Page 7
Check chains .....	Page 7
Tractor relief valve .....	Page 7
Tractor hydraulic flow rates .....	Page 7
TRACTOR PREPARATION .....	Page 8
Fitting operator guard .....	Page 8
Wheel width .....	Page 8
Ballast weight .....	Page 8
Lift links .....	Page 8
Closed centre conversion kit .....	Page 9
INITIAL ATTACHMENT TO TRACTOR .....	Page 10
OIL REQUIREMENTS .....	Page 17
FITTING CONTROLS IN CAB .....	Page 18
RUNNING UP PROCEDURE .....	Page 19
REMOVAL FROM TRACTOR .....	Page 20
STORAGE .....	Page 21
SUBSEQUENT FITTING .....	Page 21
OPERATION .....	Page 22
OPERATION GUARD .....	Page 22
PREPARATION .....	Page 22
TRACTOR CONTROLS .....	Page 22
MACHINE CONTROLS .....	Page 23
ROTOR CONTROL .....	Page 25
TRANSPORT POSITION .....	Page 27
ENGAGING DRIVE .....	Page 27
ROTOR OPERATING SPEED .....	Page 28
FORWARD SPEED .....	Page 28
HIGHWAY WORKING .....	Page 28
WORKING PRACTISES .....	Page 29
CUTTING PRECAUTIONS .....	Page 29
BREAKAWAY .....	Page 29
CUTTING SEQUENCE .....	Page 30
OVERHEAD OBSTRUCTIONS .....	Page 31
WIRE TRAP .....	Page 31
REMOVING WIRE .....	Page 31
LIFT FLOAT KIT (Optional extra) .....	Page 32
ANGLE FLOAT (Optional extra electric machines only) .....	Page 33

MAINTENANCE .....	Page 34
LUBRICATION .....	Page 34
General .....	Page 34
P.T.O. shaft .....	Page 34
HYDRAULIC SYSTEM .....	Page 35
P.T.O. GEARBOX .....	Page 36
HYDRAULIC HOSES .....	Page 36
CABLES .....	Page 37
HOSE CONNECTIONS .....	Page 38
Main control valve - cable controlled machines .....	Page 38
Main control valve - electric controlled machines .....	Page 39
Rotor control valve - Ti models only .....	Page 40
Rotor control valve - Si models only .....	Page 40

# GENERAL INFORMATION

Read this manual before fitting or operating the machine. Whenever any doubt exists contact your dealer or the McConnel Service Department for assistance.

Use only McConnel spare parts on McConnel equipment and machines.

## DEFINITIONS

The following definitions apply throughout this manual:

### WARNING

An operating procedure, technique etc., which can result in personal injury or loss of life if not observed carefully.

### CAUTION

An operating procedure, technique etc., which can result in the damage of either machine or equipment if not observed carefully.

### NOTE

An operating procedure, technique etc., which is considered essential to emphasise.

### Left and Right-Hand

This term is applicable to the machine when fitted to the tractor and viewed from the rear. This also applies to tractor references.

Record the serial number of your machine on this page and always quote this number when ordering spares. Whenever information concerning the machine is requested remember to also state the type of tractor to which it is fitted.	
MACHINE SERIAL NUMBER	INSTALLATION DATE
MODEL DETAILS	
DEALERS NAME	
DEALERS TELEPHONE NUMBER	

## FEATURES

### PA470 - ALL MODELS

- Linkage mounted.
- Right or left hand cutting.
- Operator guard.
- Hydraulic breakaway.
- 45 HP hydraulic system.
- 1.2 supercut flailhead.

### PA470 Si

- Semi independent hydraulics - tractor power for arm movement. P.T.O. pump for rotor.
- Rotor engagement by tractors P.T.O. lever.
- Cable controls.

### PA470 Ti

- Totally independent hydraulics powered by tandem P.T.O. pump.
- Independent reversible rotor on/off valve.
- Cable controls.

### PA470E

- Totally independent hydraulics powered by tandem P.T.O. pump.
- Independent reversible rotor on/off valve.
- Solenoid operated controls.
- Choice of multiswitch or joystick controls.

### OPTIONAL EXTRAS

- Lift float - all models.
- Head angle float - E models.

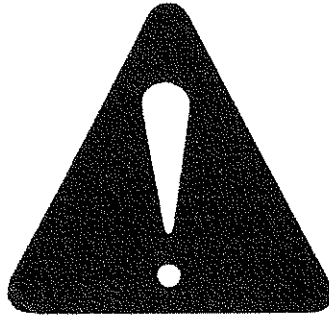

## **SAFETY INFORMATION**

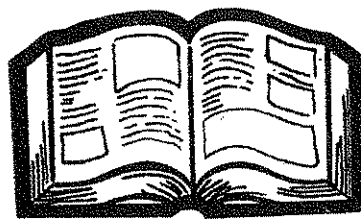

This machine has the potential to be extremely dangerous, in the wrong hands it can kill or maim. It is therefore imperative that the owner, and the operator of this machine, read the following section to ensure that they are both fully aware of the dangers that do, or may exist, and their responsibilities surrounding its use.

The operator of this machine is responsible not only for their own safety but equally for the safety of others who may come into the close proximity of the machine, as the owner you are responsible for both.

### **POTENTIAL SIGNIFICANT DANGERS ASSOCIATED WITH THE USE OF THIS MACHINE:**

- *Being hit by debris thrown by rotating components.*
- *Being hit by machine parts ejected through damage during use.*
- *Being caught on a rotating power take-off (PTO) shaft.*
- *Being caught in other moving parts i.e.: belts, pulleys and cutting heads.*
- *Electrocution from Overhead Power Lines (by contact with or 'flashover' from).*
- *Being hit by cutting heads or machine arms as they move.*
- *Becoming trapped between tractor and machine when hitching or unhitching.*
- *Tractor overbalancing when machine arm is extended.*
- *Injection of high-pressure oil from hydraulic hoses or couplings.*
- *Machine overbalancing when freestanding (out of use).*
- *Road traffic accidents due to collision or debris on the road.*

## **BEFORE USING THIS MACHINE YOU MUST:**

- *Ensure you read all sections of the operator handbook.*
- *Ensure the operator is, or has been, properly trained to use the machine.*
- *Ensure the operator has been issued with and reads the operator handbook.*
- *Ensure the operator understands and follows the instructions in operator handbook.*
- *Ensure the tractor front, rear and side(s) are fitted with metal mesh or polycarbonate guards of suitable size and strength to protect the operator against thrown debris or parts.*
- *Ensure tractor guards are fitted correctly, are undamaged and kept properly maintained.*
- *Ensure that all machine guards are in position, are undamaged, and are kept maintained in accordance with the manufacturer's recommendations.*
- *Ensure flails and their fixings are of a type recommended by the manufacturer, are securely attached and that none are missing or damaged.*
- *Ensure hydraulic pipes are carefully and correctly routed to avoid damage by chaffing, stretching or pinching and that they are held in place with the correct fittings.*
- *Always follow the manufacturer's instructions for attachment and removal of the machine from the tractor.*
- *Check that the machine fittings and couplings are in good condition.*
- *Ensure the tractor meets the minimum weight recommendations of the machine manufacturer and that ballast is used as necessary.*
- *Always inspect the work area thoroughly before starting to note obstacles and remove wire, bottles, cans and other debris.*
- *Use clear suitably sized warning signs to alert others to the nature of the machine working within that area. Signs should be placed at both ends of the work site. (It is recommended that signs used are of a size and type specified by the Department of Transport and positioned in accordance with their and the Local Highways Authority guidelines).*
- *Ensure the operator is protected from noise. Ear defenders should be worn and tractor cab doors and windows must be kept closed. Machine controls should be routed through proprietary openings in the cab to enable all windows to be shut fully.*
- *Always work at a safe speed taking account of the conditions i.e.: terrain, highway proximity and obstacles around and above the machine.*
- *Extra special attention should be applied to Overhead Power Lines. Some of our machines are capable of reach in excess of 8 metres (26 feet) this means they have the potential to well exceed, by possibly 3 metres (9' 9"), the lowest legal minimum height of 5.2 metres from the ground for 11,000 and 33,000 volt power lines. It cannot be stressed enough the dangers that surround this capability, it is therefore vital that the operator is fully aware of the maximum height and reach of the machine, and that they are fully conversant with all aspects regarding the safe minimum distances that apply when working with machines in close proximity to Power Lines. (Further information on this subject can be obtained from the Health & Safety Executive or your Local Power Company).*
- *Always disengage the machine, kill the tractor engine, remove and pocket the key before dismantling for any reason.*

- *Always clear up all debris left at the work area, it may cause hazard to others.*
- *Always ensure when you remove your machine from the tractor that it is left in a safe and stable position using the stands and props provided and secured if necessary.*

## **WHEN NOT TO USE THIS MACHINE:**

- *Never attempt to use this machine if you have not been trained to do so.*
- *Never uses a machine until you have read and understood the operator handbook, are familiar with, and practiced the controls.*
- *Never use a machine that is poorly maintained.*
- *Never use a machine if guards are missing or damaged.*
- *Never use a machine on which the hydraulic system shows signs of wear or damage.*
- *Never fit, or use, a machine on a tractor that does not meet the manufacturer's minimum specification level.*
- *Never use a machine fitted to a tractor that does not have suitable front, rear and side(s) cab guarding made of metal mesh or polycarbonate.*
- *Never use the machine if the tractor cab guarding is damaged, deteriorating or badly fitted.*
- *Never turn a machine cutting head to an angle that causes debris to be ejected towards the cab.*
- *Never start or continue to work a machine if people are nearby or approaching - Stop and wait until they are at a safe distance before continuing.*
- *Never attempt to use a machine on materials in excess of its capability.*
- *Never use a machine to perform a task it has not been designed to do.*
- *Never operate the tractor or machine controls from any position other than from the driving seat, especially whilst hitching or unhitching the machine.*
- *Never carry out maintenance of a machine or a tractor whilst the engine is running – the engine should be switched off, the key removed and pocketed.*
- *Never leave a machine unattended in a raised position – it should be lowered to the ground in a safe position on a level firm site.*
- *Never leave a tractor with the key in or the engine running.*
- *Never carry out maintenance on any part or component of a machine that is raised unless that part or component has been properly substantially braced or supported.*
- *Never attempt to detect a hydraulic leak with your hand – use a piece of cardboard.*
- *Never allow children near to, or play on, a tractor or machine under any circumstances.*

## **ADDITIONAL SAFETY ADVICE**

### **TRAINING**

Operators need to be competent and fully capable of operating this machine in a safe and efficient way prior to attempting to use it in any public place. We advise therefore that the prospective operator make use of relevant training courses available such as those run by the Agricultural Training Board, Agricultural Colleges, Dealers and McConnel.

### **WORKING IN PUBLIC PLACES**

When working in public places such as roadsides, consideration should be paid to others in the vicinity. Stop the machine immediately when pedestrians, cyclists and horse riders etc. pass. Restart only when they are at a distance that causes no risk to their safety.

### **WARNING SIGNS**

It is advisable that any working area be covered by suitable warning signs and statutory in public places. Signs should be highly visible and well placed in order to give clear advanced warning of the hazard. Contact the Department of Transport or your Local Highways Authority to obtain detailed information on this subject. The latter should be contacted prior to working on the public highway advising them of the time and location of the intended work asking what is required by way of signs and procedure. – *'Non-authorized placement of road signs may create offences under the Highways Act'*.

### **SUGGESTED WARNING SIGNS REQUIRED**

*"Road works ahead" warning sign with a supplementary "Hedge cutting" plate. "For 1 mile" or appropriate shorter distance may be added to the plate.*

*"Road narrows" warning sign with supplementary "Single file traffic" plate.*

*White on blue "Keep right" arrow sign on rear of machine.*

### **USE OF WARNING SIGNS**

- *On two way roads one set of signs is needed facing traffic in each direction.*
- *Work should be within 1 mile of the signs.*
- *Work only when visibility is good and at times of low risk e.g.: NOT during 'rush-hour'.*
- *Vehicles should have an amber flashing beacon.*
- *Ideally, vehicles should be conspicuously coloured.*
- *Debris should be removed from the road and path as soon as practicable, and at regular intervals, wearing high visibility clothing and before removing the hazard warning signs.*
- *Collect all road signs promptly when the job is completed.*

---

Although the information given here covers a wide range of safety subjects it is impossible to predict every eventuality that can occur under differing circumstances whilst operating this machine. No advice given here can replace 'good common sense' and 'total awareness' at all times but will go a long way towards the safe use of your McConnel machine.

---



# FITTING

## TRACTOR REQUIREMENTS

Minimum tractor weights including ballast weight if necessary

All models - 3000 kg

Min Hp requirements

All models - 50 Hp

Linkage

Category II

P.T.O. shaft

Tractor must be equipped with a live drive P.T.O to enable forward motion to be stopped while the flail head continues to operate.

Linkage isolation

A linkage isolation facility is necessary for Si models only.

Check chains/stabilizers

Check chains or stabiliser bars must be fitted and tightened.

Tractor relief valve

For Si models only tractor relief valve must be set above 2000 psi (140 bar)

Tractor hydraulic flow rate

Hydraulic flow rates are not crucial for Si models

## TRACTOR PREPARATION

**Fitting Tractor Guard:** Use tractor with safety glass windows if possible and fit Operator guard (*part no. 73 13 324*) using the hooks provided. Shape mesh to cover all vulnerable areas. Remember the driver must be looking through mesh and/or polycarbonate glazing when viewing the flail head in any working position - unless the tractor/cab manufacturer can demonstrate that the penetration resistance is equivalent to, or higher than, that provided by mesh/polycarbonate glazing. If the tractor has a roll bar only, a frame must be made to carry both mesh and polycarbonate glazing.

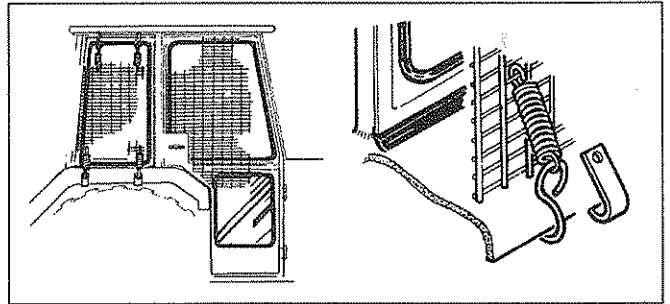

**Wheel Width:** Set wheel widths as wide as possible.

**Lift Links:** Adjust lift links until they are equal length.

**Tractor Ballast:** It is imperative when attaching 'third-party' equipment to a tractor that the maximum possible stability of the machine and tractor combination is achieved – this can be accomplished by the utilisation of 'ballast' in order to counter-balance the additional equipment added.

**Front weights** may be required to place 15% of total outfit weight on the front axle for stable transport on the road and to reduce 'crabbing' due to the drag of the cutting unit when working on the ground.

**Rear weights** may be required to maintain a reasonable amount of rear axle load on the opposite wheel from the arms when in work; for normal off-ground work i.e. hedge cutting this should be 20% of rear axle weight or more for adequate control, and for ground work i.e. verge mowing with experienced operators, this can be reduced to 10%.

All factors must be addressed in order to match the type and nature of the equipment added to the circumstances under which it will be used – in the instance of Power Arm Hedgecutters it must be remembered that the machines centre of gravity during work will be constantly moving and will differ from that during transport mode, therefore balance becomes critical.

### **Factors that effect stability:**

- *Centre of gravity of the tractor/machine combination.*
- *Geometric conditions, e.g. position of the cutting head and ballast.*
- *Weight, track width and wheelbase of the tractor.*
- *Acceleration, braking, turning and the relative position of the cutting head during these operations.*
- *Ground conditions, e.g. slope, grip, load capability of the soil/surface.*
- *Rigidity of implement mounting.*

### **Suggestions to increase stability:**

- *Increasing rear wheel track; a tractor with a wider wheel track is more stable.*
- *Ballasting the wheel; it is preferable to use external weights but liquid can be added to around 75% of the tyre volume – water with anti-freeze or the heavier Calcium Chloride alternative can be used.*
- *Addition of weights – care should be taken in selecting the location of the weights to ensure they are added to a position that offers the greatest advantage.*
- *Front axle locking; a ram can be used to 'lock' the front axle in work only – locking the axle moves the 'balance line' and can be used to transfer weight to the front axle from the rear (check with tractor manufacturer).*

The advice above is offered as a guide for stability only and is not a guide to tractor strength - it is therefore recommended that you consult your tractor manufacturer or local dealer to obtain specific advise on this subject, additionally advice should be sought from a tyre specialist with regard to tyre pressures and ratings suitable for the type and nature of the machine you intend to fit.

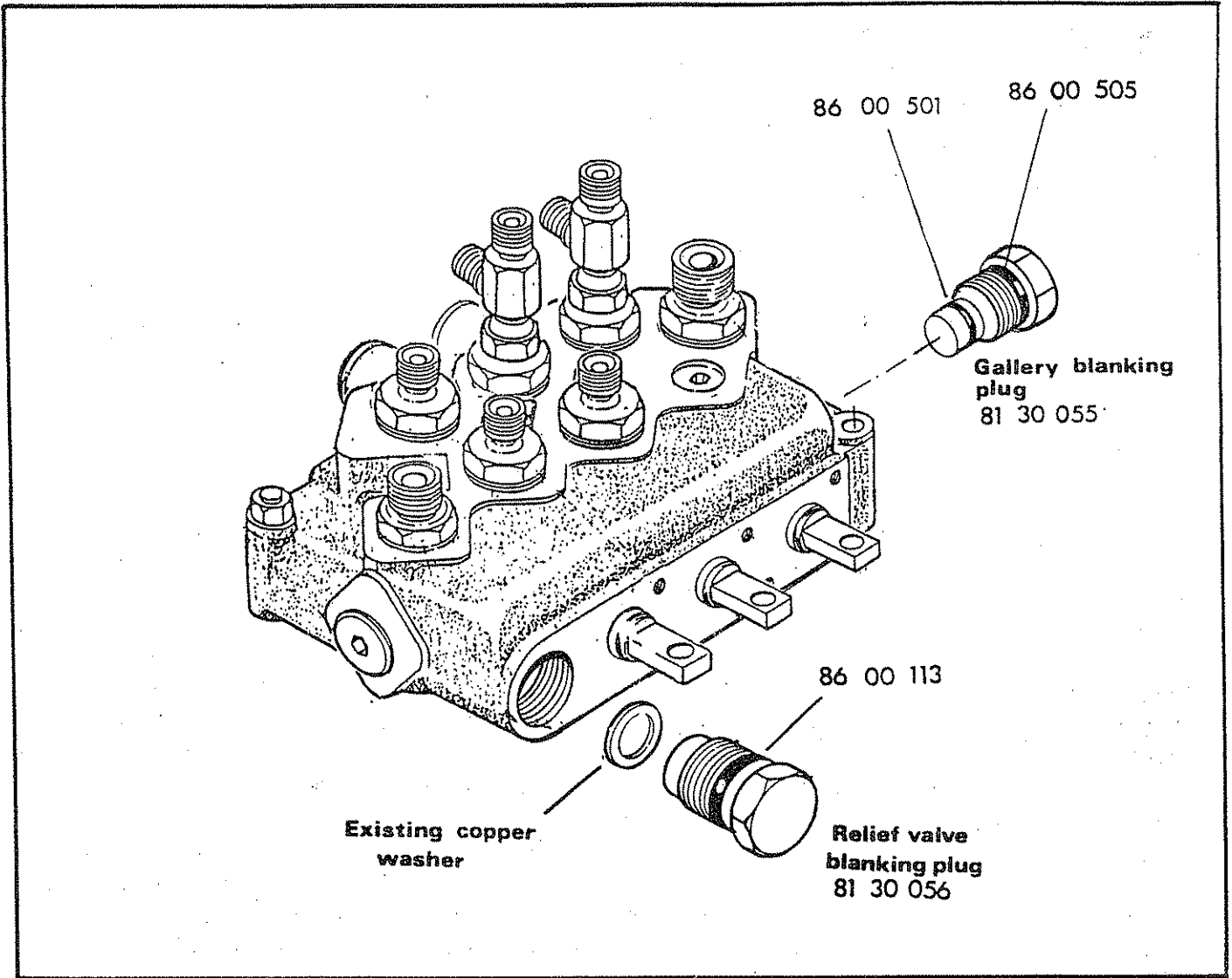

**CLOSED CENTRE CONVERSION KIT 81 30 059 for S.i. models only**

A control valve conversion kit Part No. 81 30 059 consists of a relief valve blanking plug which should be installed in place of the existing relief valve and a pressure gallery blanking plug which is installed in place of the standard blanking plug at the valve outlet end next to the lift ram gland connection.

Take care when extracting the relief valve not to damage the copper sealing washer as it is re-used.

When working in this mode the tractor's pressure control valve must not exceed 2500 P.S.I. (170 Bar).

# INITIAL ATTACHMENT TO TRACTOR

1. Choose a firm level site.

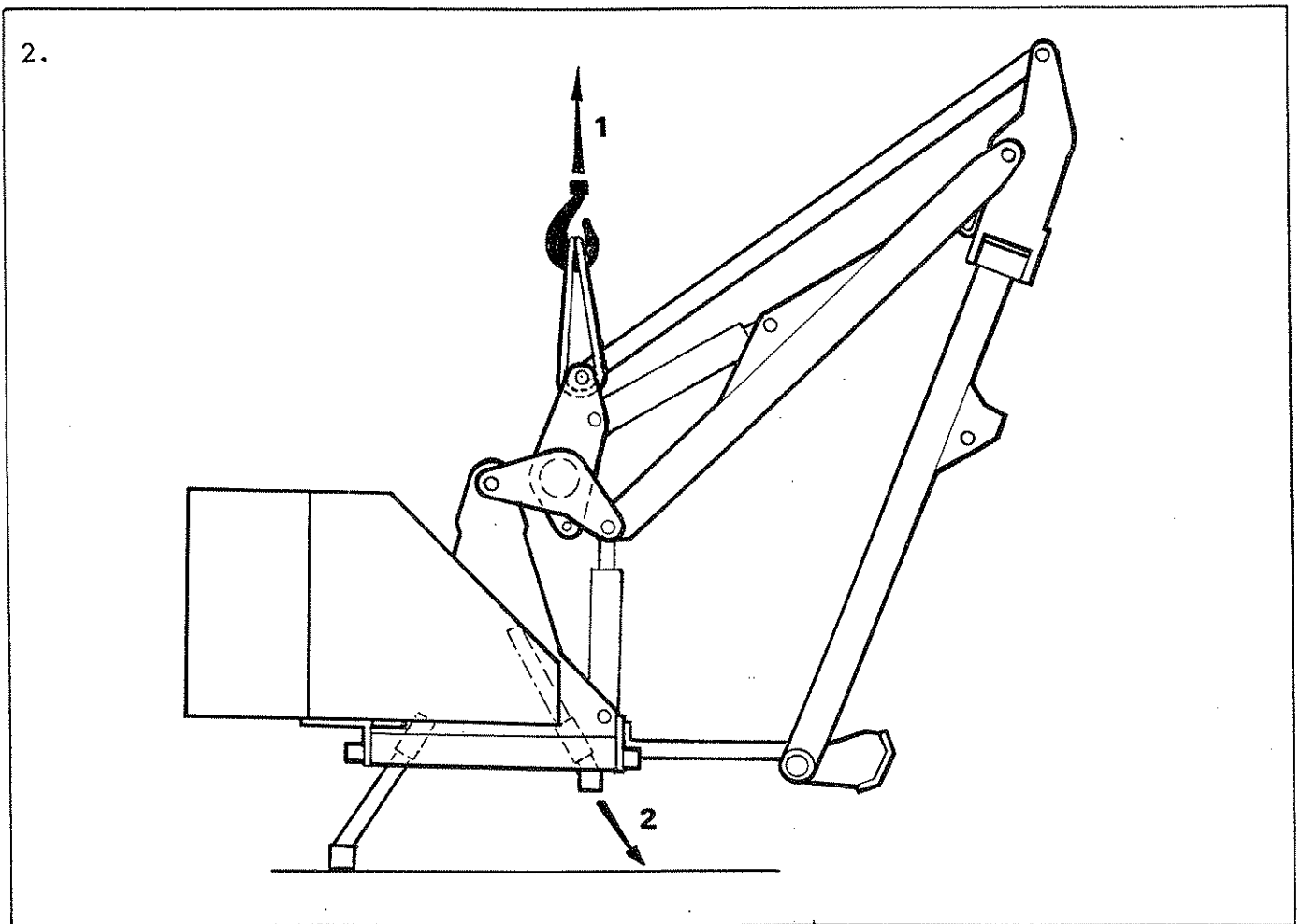

3. Cut banding straps and remove transport strap, loose items and stabiliser.

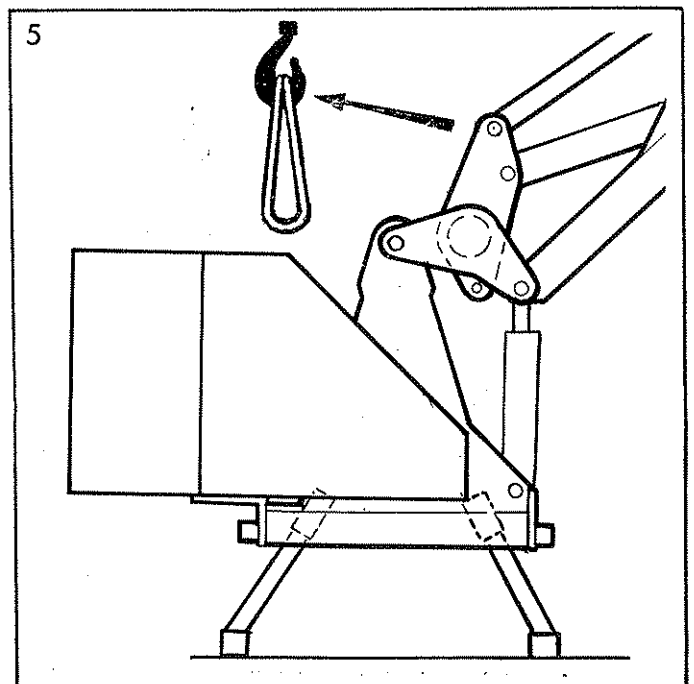
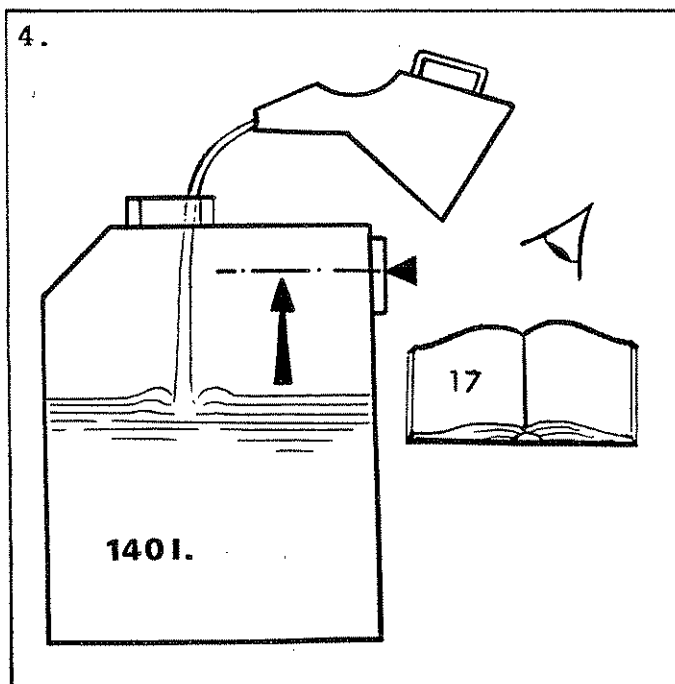

6

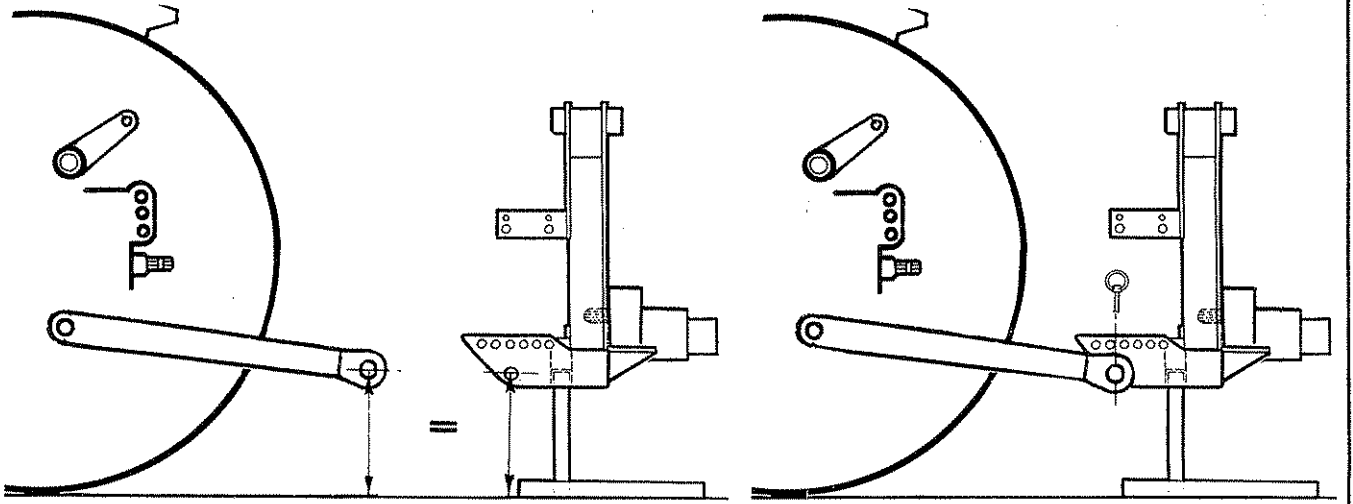

7

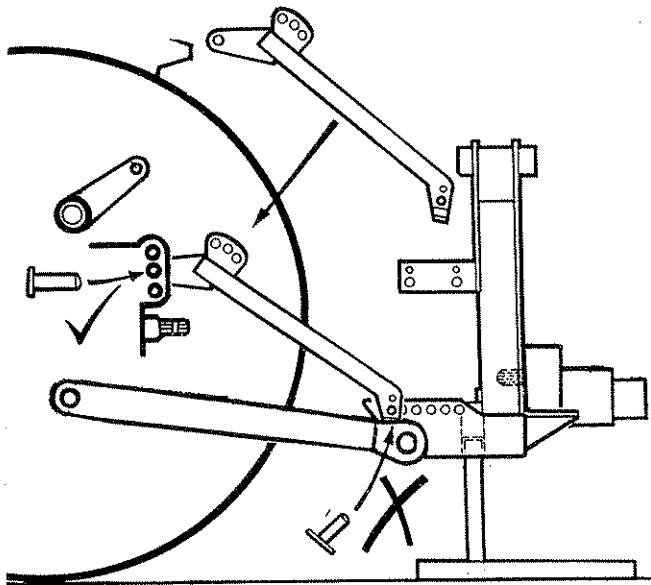

8

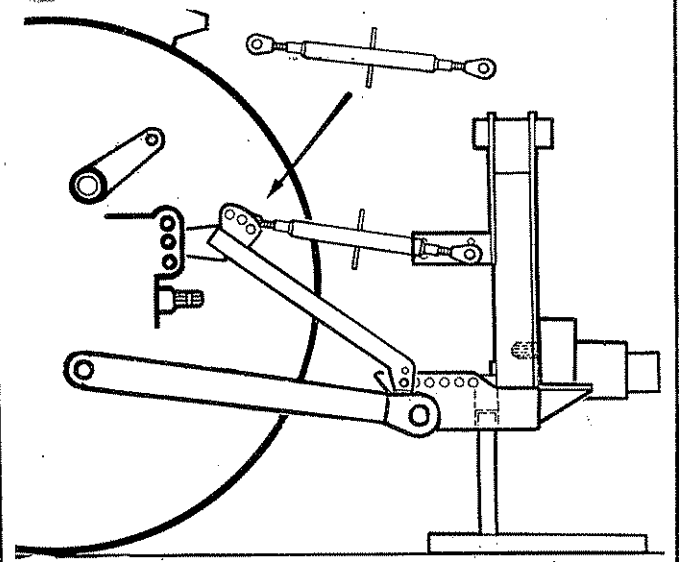

9

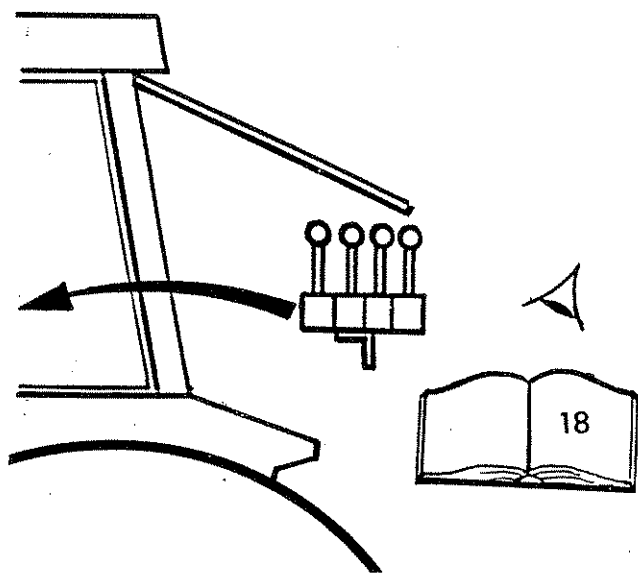

10

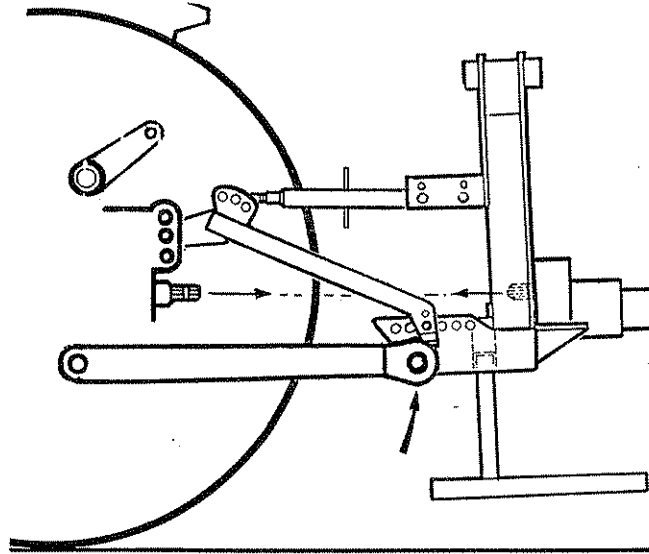
**WARNING**

The quadrant lever or machine controls must be operated from the tractor seat. During this operation ensure no one is standing on or amongst the linkage arm or bars.

**Note:**

As lift occurs be aware the machinery may tilt slightly.

11

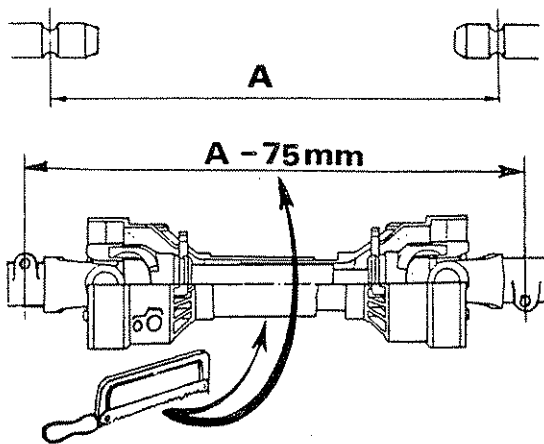

Measure 'A'.  
Cut PTO shaft equal amounts of both halves to measure. A - 75mm when fully closed.

12

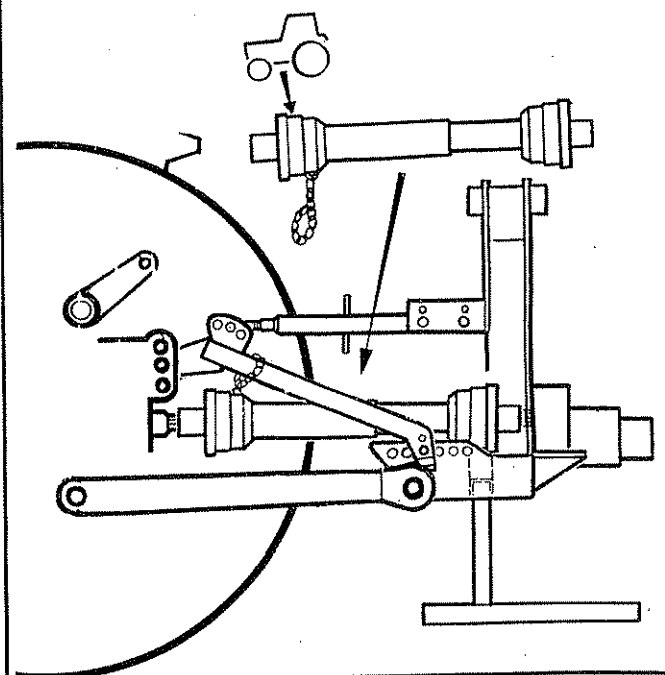

13. On semi independent machines only connect up the supply and return hoses.

Supply - from tractors auxiliary service  
Return - to tractors transmission casing - see tractor handbook  
Select tractors external services.

On totally independent machines only check the rotor control lever is in the "OFF" position and engage the P.T.O.

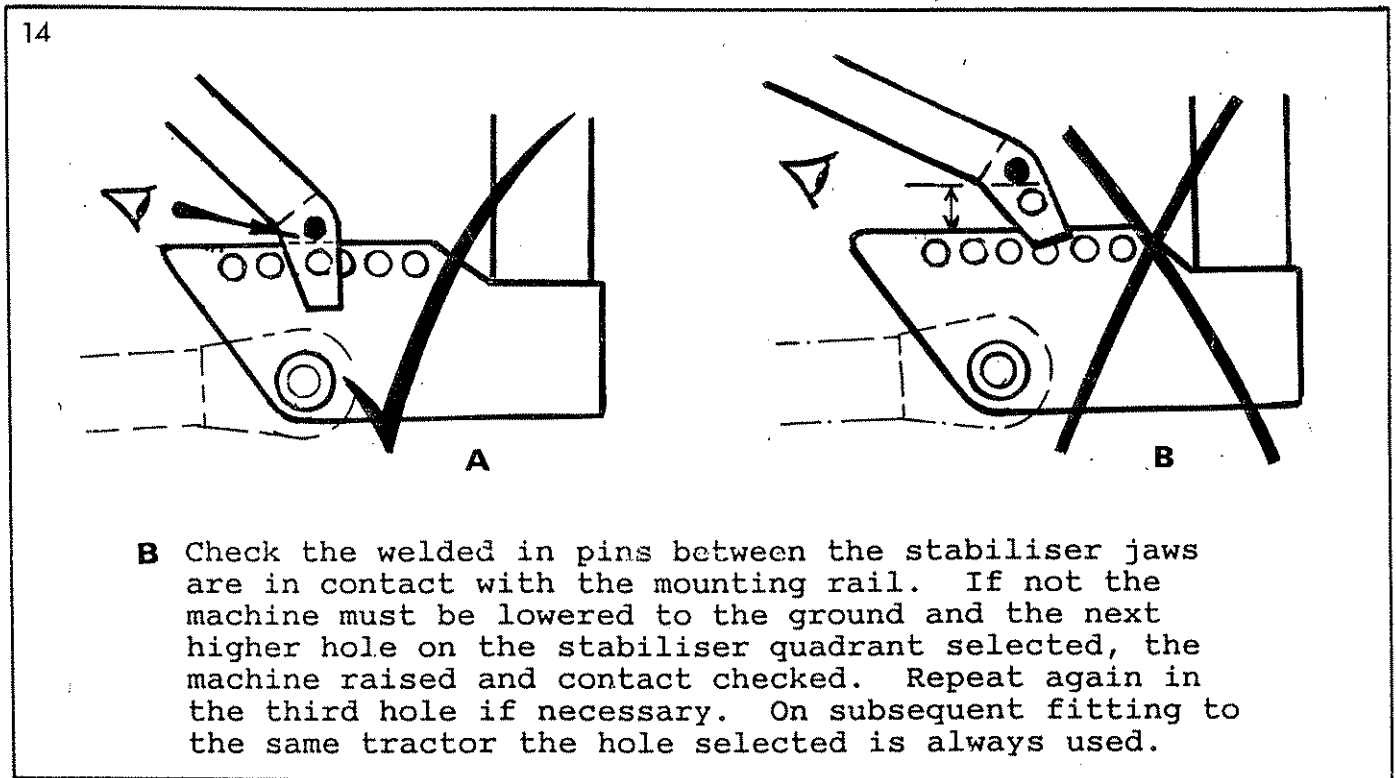

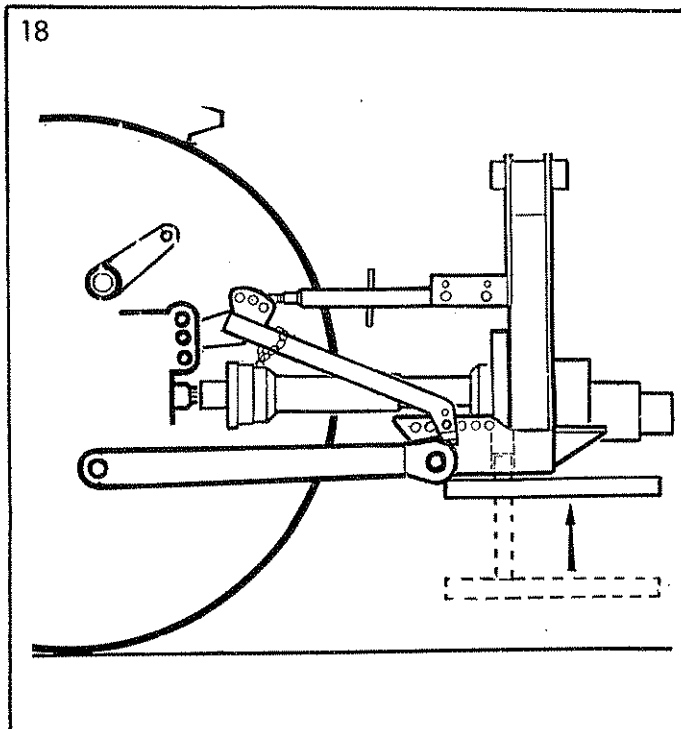
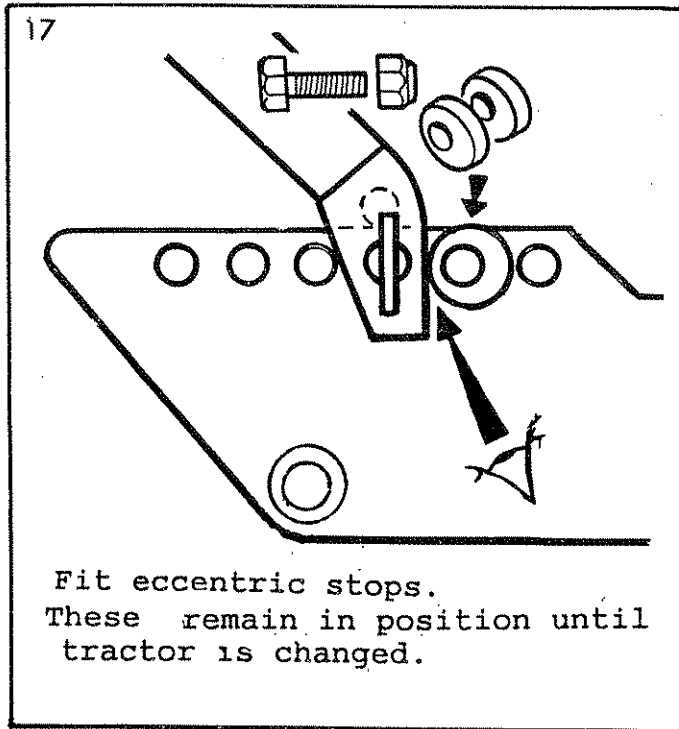
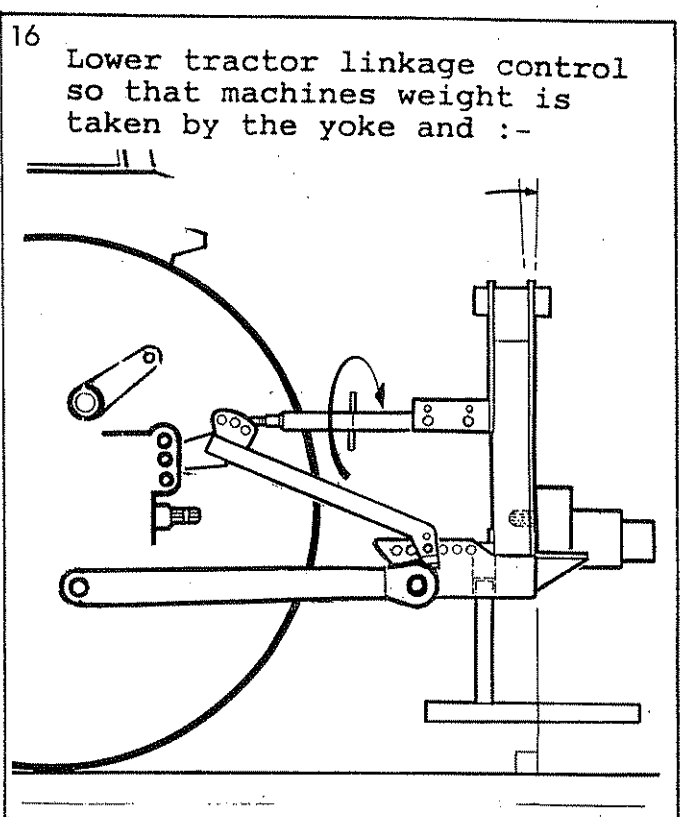
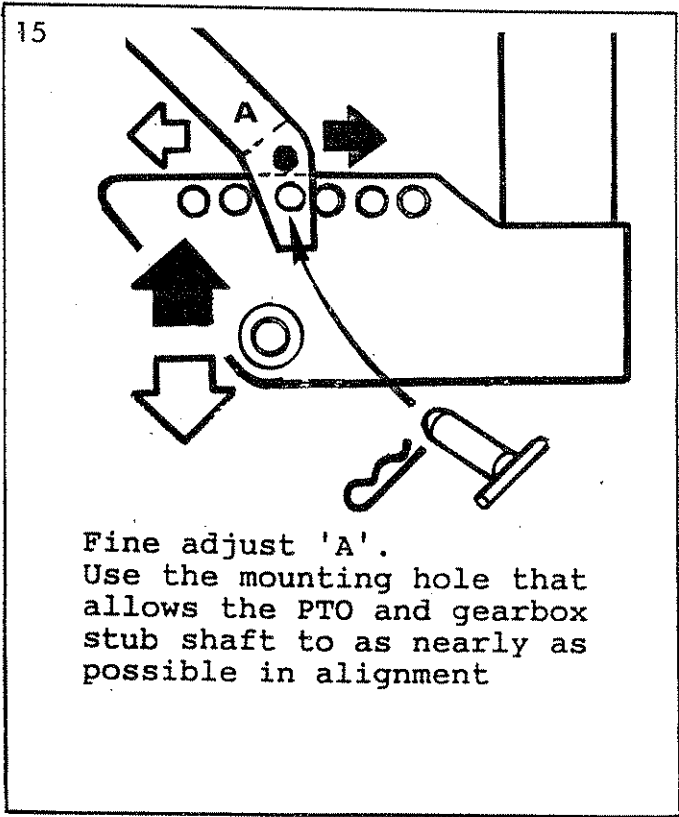

19 Ensure the lift ram tap is fully open.



20

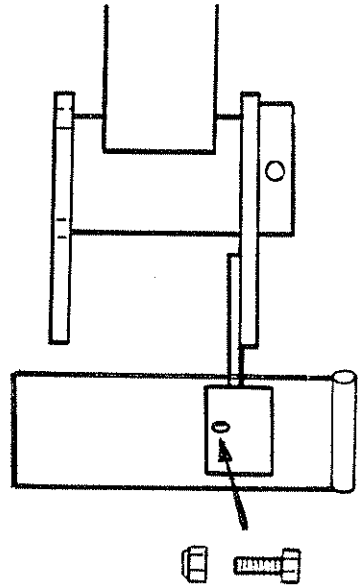
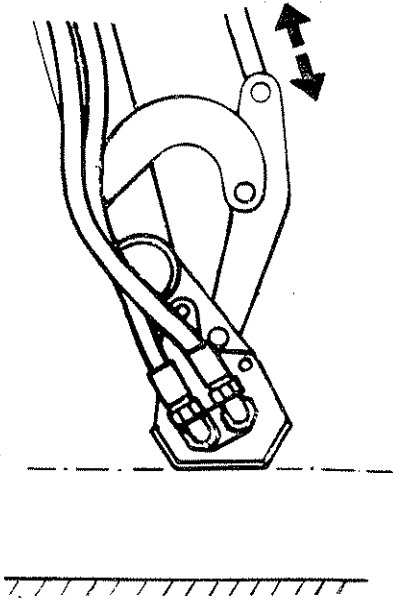

21

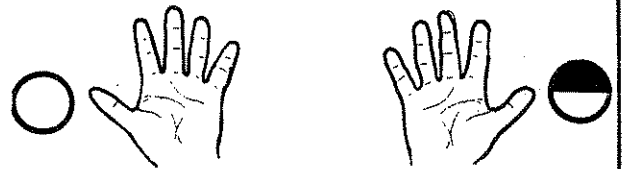
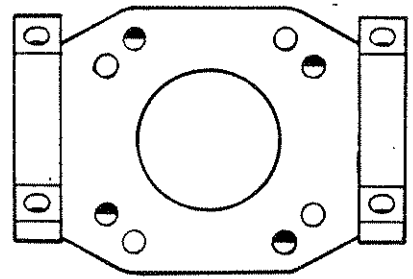
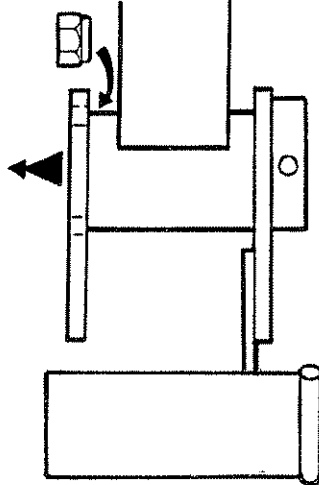
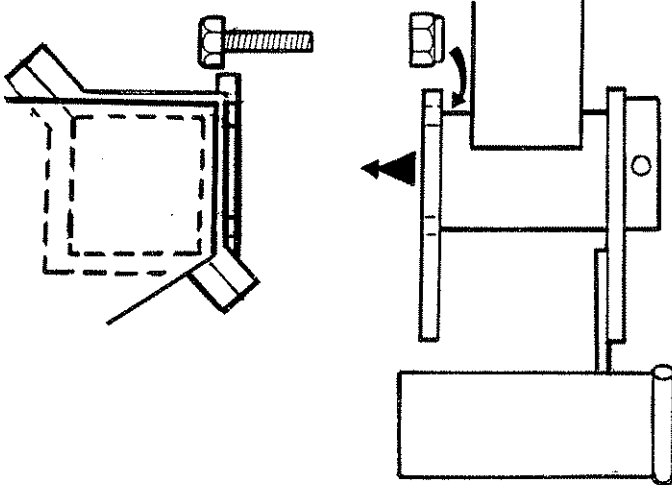

22 Connect hoses.

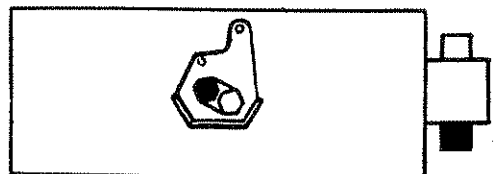
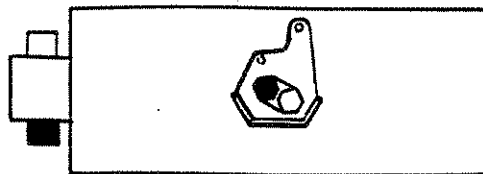
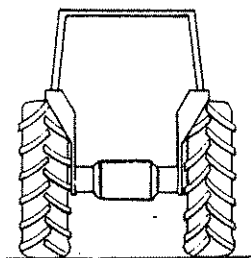
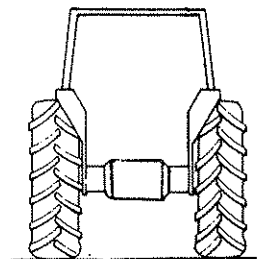
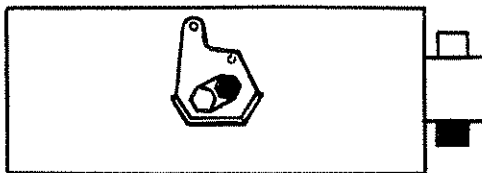
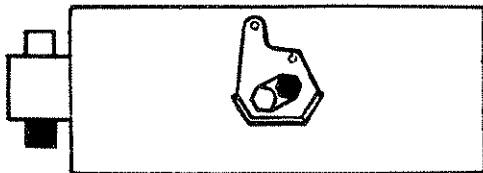

- 23 With the arms at half reach and with the flail head clear of the ground carry out final adjustment of the lift arm levelling box to bring the main frame horizontal.
- 24 Tighten check chains/stabiliser bars.
- 25 Carefully operate the machine through its full range of movements whilst checking that hoses are not strained, pinched, chafed or kinked and that all movements are functioning correctly.
- 26 Fold machine into the transport position (see page27)  
The machine is now ready to transport to the worksite.

## OIL REQUIREMENTS

### Tank

Fill the reservoir to approximately 2" below the top of the tank.  
The capacity is approximately 140 litres ( 30imp galls)

Do not overfill.

Supplier	Cold or temperate climate	Hot climate
Castrol	Agricastrol hydraulic oil Hy-spin AWS 46	Hy-spin AWS68
Shell	Tellus 46	Tellus 68
Mobil	D.T.E. 25	D.T.E.26
Esso	Nuto 'H' or 'A' 46	Nuto 'H'or'A' 68
Texaco	Rando HD 46	Rando D 68
Gulf	Hydrasil 46	Hydrasil 68
B.P.	Energol HLP 46	Energol HLP 68
Dalton	Silkolene Dove 46 or Derwent 46	Silkolene Dove 68 or Derwent 68
Elf	Hydrelf 46	Hydrelf 68

### Gearbox

Check the gearbox oil level. On level ground gearbox should be filled until oil dribbles out of the level plug. Top up if required with a suitable light gear oil.

## FITTING CONTROL UNIT IN CAB

A mounting pillar is supplied to which the control unit is bolted. The pillar is bolted to the tractor ensuring that no structural member of the cab or roll bar is drilled and it can be bent or twisted to achieve a comfortable working position.

### Electric controlled models only

The supply cable with the disconnected plug should be connected to the tractors electrical system preferably at the fuse box or the ignition switch where it can be switched off with the tractors isolation key.

The control is 12 volt D.C. operated; the brown lead is Positive and the blue is Negative.

The control lever for the cable operated Flail rotor on/off valve is then bolted into position on the mounting stalk.

### Cable controlled models

The control unit is bolted to an angled mounting bracket in either a transverse or longitudinal position thus giving a variety of mounting positions, which in conjunction with the flexibility of the mounting pillar will enable a satisfactory working position to be achieved.

If so wished an "in line" installation is possible by unbolting the cable ends from the pivot boxes and rotating through 180 degrees before re-assembling.

In deciding the final position of the control box remember not to exceed the minimum acceptable bend radii of 8" for the cables.

## RUNNING UP PROCEDURE

### Ti models only

Ensure that the rotor control valve is in "STOP" position, start tractor, engage P.T.O. allow the oil to circulate through the return line filter for about 5 minutes without operation of the armhead control lever.

Operate the armhead levers through their complete range ensuring that all movements are functioning correctly.

Place the flail head at a safe attitude and move the rotor control to "START" position. After initial fluctuation the rotor should settle to a steady speed. Increase P.T.O. speed to approximately 360 rpm. and run for a further five minutes before disengaging and stopping tractor.

Check the hose runs and observe that they are free from any pinching, chafing straining or kinks. Re-check the oil level in the tank and top up as necessary.

### Si models only

Ensure P.T.O. lever is in neutral position, and isolate tractor hydraulic linkage. Start tractor and select external service supply. Allow the tractor to run for several minutes before attempting to operate any of the machine control levers.

On operating move the levers through their complete range ensuring that all movements are functioning correctly.

Check the tractor rear axle oil level and top up if necessary.

Place the flail head at a safe attitude and bring tractor engine revolutions to 1000 rpm. Engage P.T.O. and allow the rotor to run for several minutes. Do not leave the tractor cab or allow anyone to approach the flail head at this time.

### Caution

Do not allow the pump to continue working if the rotor does not turn-Overheating and serious damage to the pump can be caused in a very short time.

After running up the machine increase P.T.O speed to approximately 360 rpm. and run for a further five minutes to allow the oil to circulate through the return line filter before disengaging the P.T.O. and stopping tractor.

Check the hose runs and observe that they are free from any pinching, chafing, straining or kinks. Re-check the oil level in the tank and top up as necessary.

REMOVAL FROM TRACTOR

DANGER

READ CAREFULLY BEFORE COMMENCING TO REMOVE THE MACHINE FROM THE TRACTOR.

THE ORDER OF THE FOLLOWING STEPS MUST BE FOLLOWED EXACTLY

DISCONNECTING THE TOP LINK MUST BE THE LAST OPERATION PRIOR TO DRIVING THE TRACTOR AWAY FROM THE MACHINE.

**WARNING**

Do not operate quadrant lever of machine controls through the rear cab window whilst standing on or amongst linkage components. Always seek assistance.

Select a firm level site for parking the machine.

Lower the parking legs in their sockets and secure in the down position.

Raise the machine on the tractors linkage until the weight is taken off the stabiliser. Remove the lower stabiliser pins.

Unscrew the lift ram tap.

Lower the machine to the ground.

Extend the arms and place the flail head on the ground at half reach.

Disengage tractor P.T.O. and remove.

Disconnect stabiliser bars or loosen check chains as applicable.

Unbolt the control unit from the mounting pillar, remove from tractor cab and stow the levers or switchbox clear of the ground. On Si models only disconnect the supply and return hoses and stow with hose ends clear of the ground. Blank off the end of the return hose with a plug or insulating tape.

Remove draft links. Disconnect the stabiliser from the tractors top hitch position. Allow the stabiliser to slide along the rail until it contacts the eccentric stops.

## STORAGE

If machine is to be left standing for an extended period of time, lightly coat the exposed portions of the ram rods with grease. Subsequently this grease should be wiped off before the rams are next moved.

If the machine has to be stored outside tie a piece of tarpaulin or canvas over the control assembly do not use a plastic fertilizer bag which could lead to rapid corrosion.

## SUBSEQUENT ATTACHMENT TO IDENTICAL TRACTOR

Couple up tractor draft links

Connect stabiliser into tractors lowest top hitch position.

Raise the machine on the tractors linkage until the stabiliser contacts the eccentric stops.

Fit stabiliser lower pins.

Mount controls in cab.

Fit PTO shaft and attach torque chain to a convenient point to prevent the shaft guard rotating.

Place arms in work position at half reach and adjust lift arm levelling box to bring frame horizontal.

Tighten check chains.

Stow parking legs.

Fold machine into transport position (see page 27).

Proceed to the worksite.

## SUBSEQUENT ATTACHMENT TO DIFFERENT TRACTOR

Remove stabiliser and top link from machine and separate. Refer to "initial attachment to tractor" and follow steps:-

6, 7, 8, 9, 10, 11, 12, (13 Si only), 16, 17, 18, 19, 20, 21, 25, 26, 27, 28.

## OPERATION

### OPERATOR GUARD

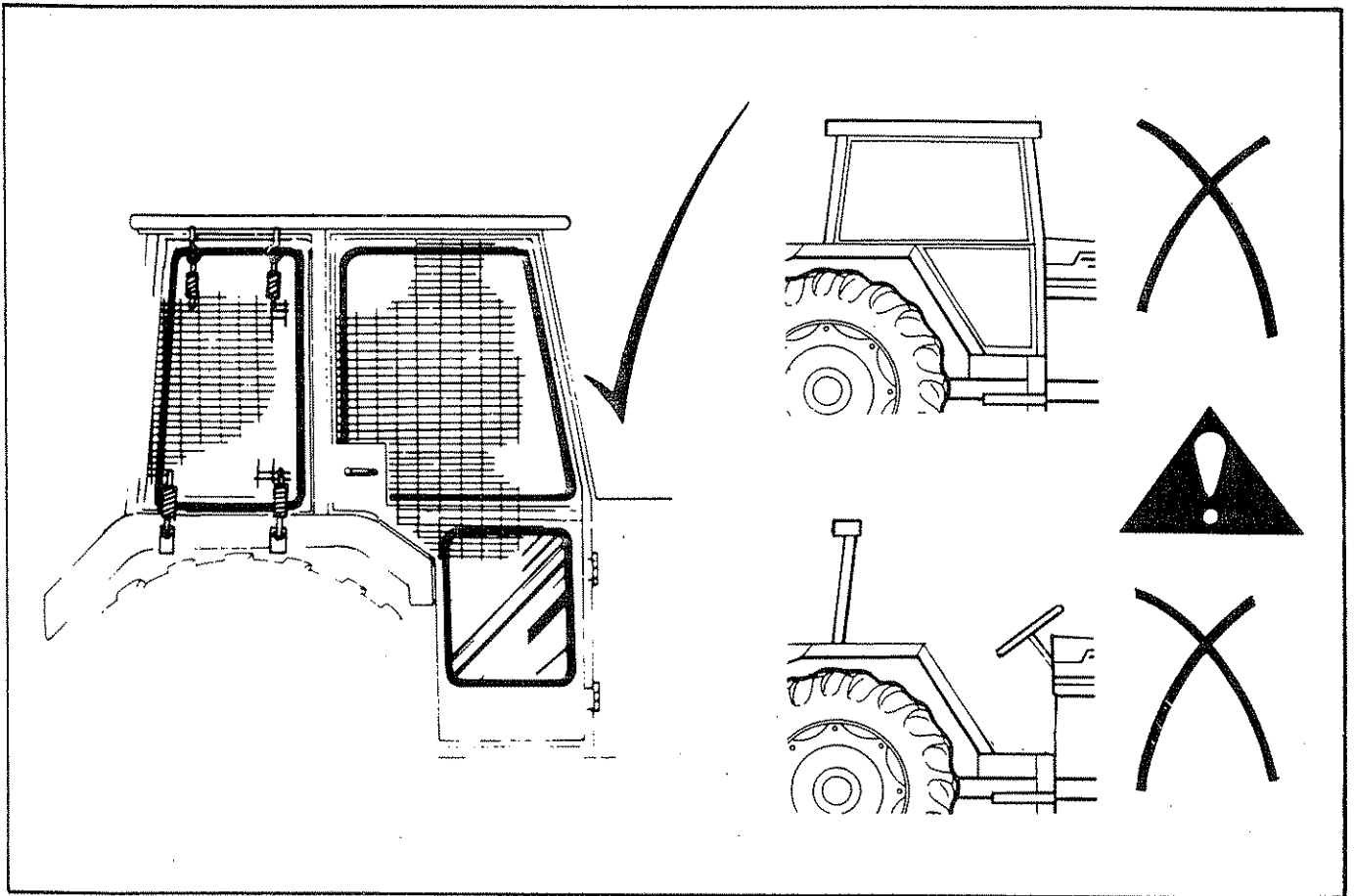

### PREPARATION

Read the book first

Practise in an open space without rotor running until familiar with controls.

Caution: Take care when working with the head close in as it can hit the tractor.

### TRACTOR CONTROLS

For Si models only the tractors linkage will need to be isolated.



# TRACTOR CONTROLS

For Si models only the tractors linkage will need to be isolated.

## MACHINE CONTROLS

### Cable machines

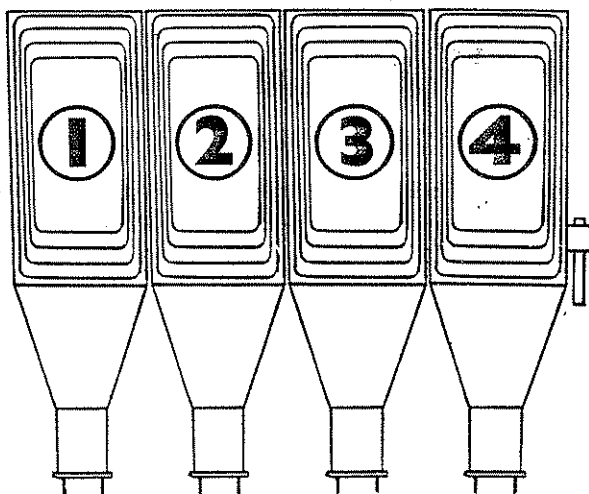

### Electric machines

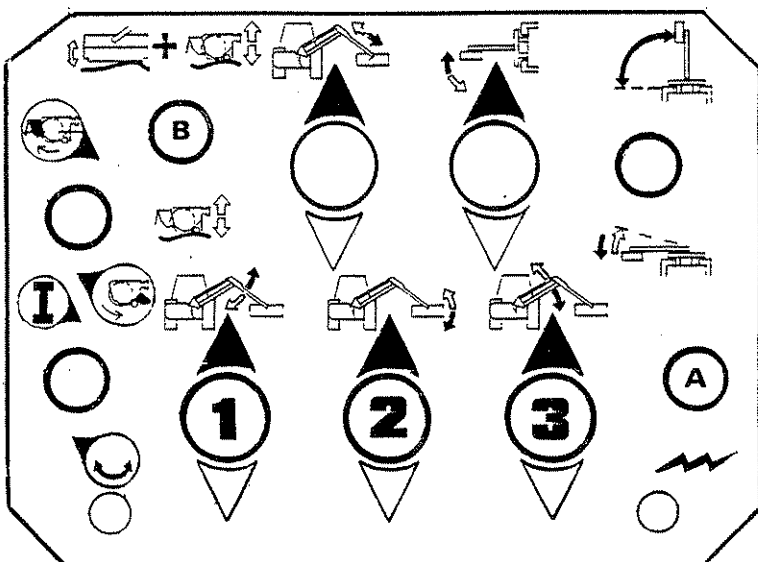

### Switch functions -

A Power on/off

B Head float on/off  
(if fitted)

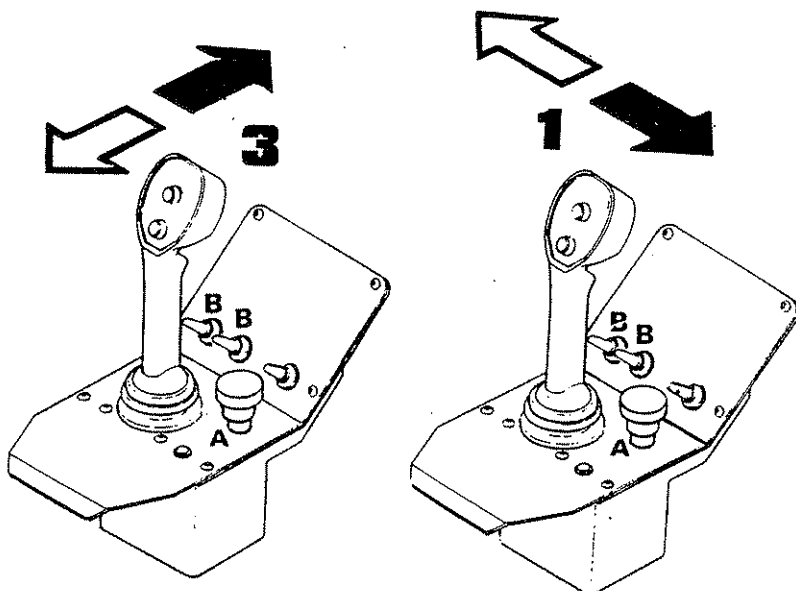

# ARM CONTROLS

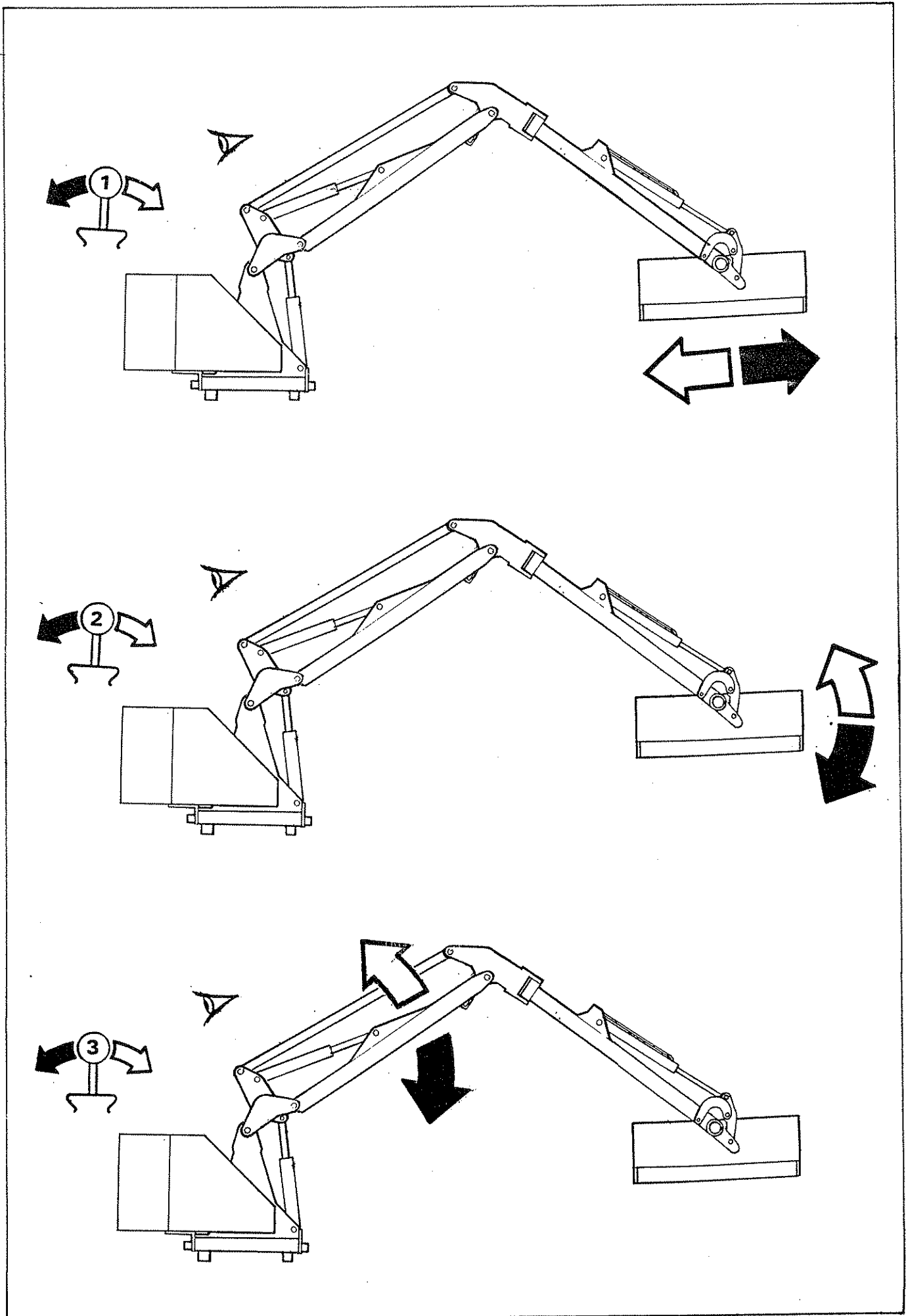

ROTOR CONTROLS - T.i. machines only

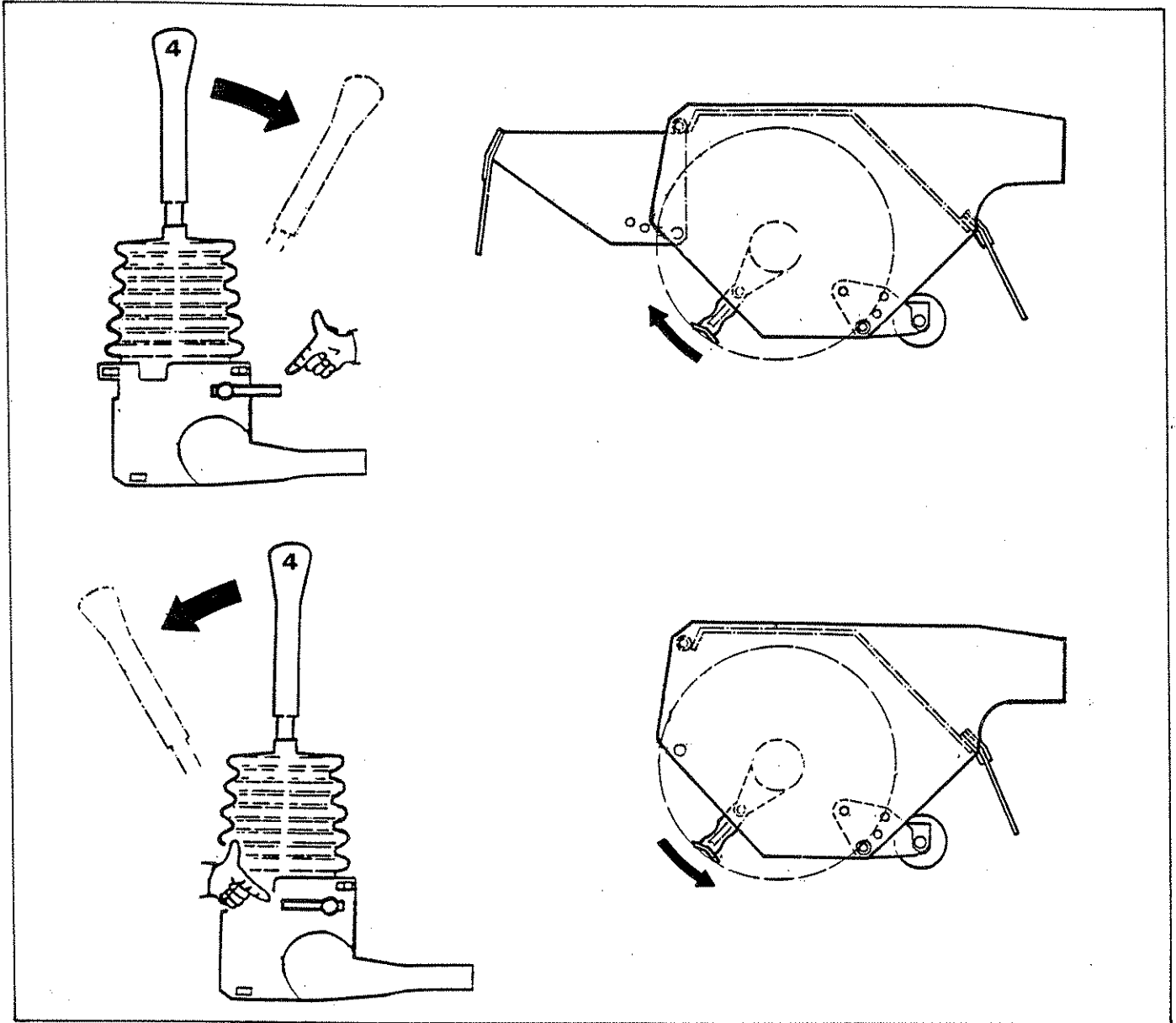

Reversing rotation T.i. models only

Select "Rotor OFF"

Wait until the rotor has stopped turning.

Turn the small lever on the side of the rotor control lever pivot box through 180 degrees. This will reset the control lever stop inside the pivot box and allow opposite rotation to be selected.

**ROTOR CONTROL - S.i. machines only**

Rotor on/off is controlled by operation of the tractors P.T.O. lever

**To start rotor:-**

Bring tractor engine revs up to 1000 RPM

Engage P.T.O.

**To stop rotor:-**

Disengage P.T.O. Do not leave tractors seat until the rotor is stationery.

**Reversing rotation - S.i. models only**

Fully extend the armhead and lower flail to the ground to minimise oil loss.

Release the hoses from the rotor relief valve and interchange. Do not interchange the flail supply and return hoses at any other point as the hose routing and cross overs in the installation are necessary to allow the hoses to flex correctly during arm movements.

To ascertain the direction of cut without running the machine the following applies.

Connection MP - lower motor rigid pipe ) upward cutting  
Connection MR - Upper motor right pipe )

Connection MP - Upper motor rigid pipe ) downward cutting  
Connection MR - Lower motor rigid pipe )

## TRANSPORT POSITION

The machine must be transported on the public highway mounted as compactly on the tractor as the machine will allow.

Position the arm where the dipper is horizontal and approximately 1.2m (four feet) clear of the ground.

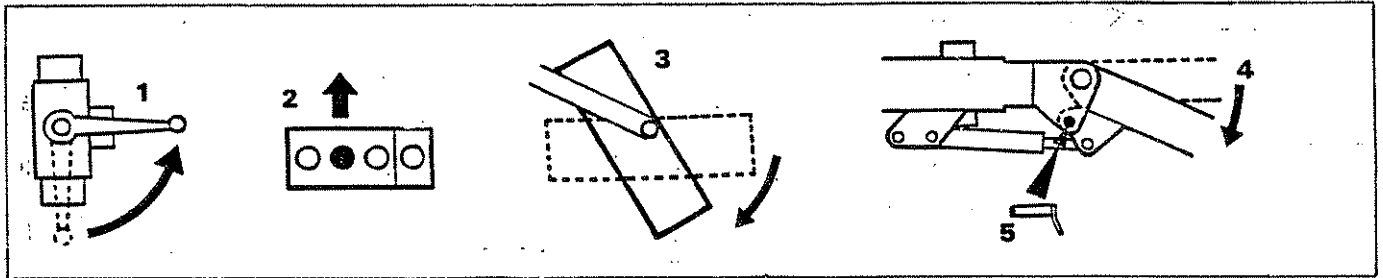

Raise the lever on the park selector diverter valve to the 'up' position.

Select 'angle down'. When the flail head completes its movement the breakaway ram will retract and pull the dipper arm into the transport position.

Engage the dipper transport lock pin.

Select 'Reach In and Lift Up'

Fully screw in the lift ram tap.

To revert to 'work' mode the above procedures are reversed

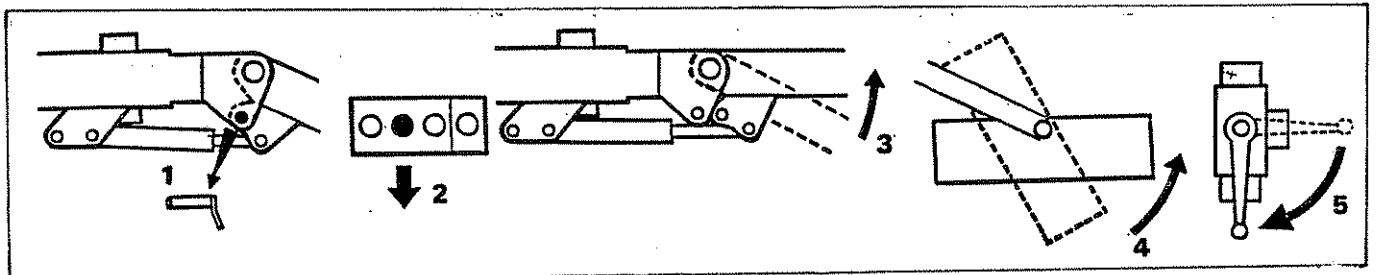

## ENGAGING DRIVE

### T.i. models only

Ensure that the rotor control lever is in the 'Stop' position before engaging the P.T.O. shaft. Allow the oil to circulate for a minute or so before operating the armhead levers. Position the flail head in a safe position, increase the engine speed to a high idle and move rotor control lever to 'START'. After initial surging the rotor will run at an even speed.

### S.i. models only

Place the flail head at a safe attitude and bring the tractor engine revolutions to 1000 r.p.m. Engage the P.T.O. and slowly increase revs. until operating speeds are attained.

ROTOR OPERATING SPEED

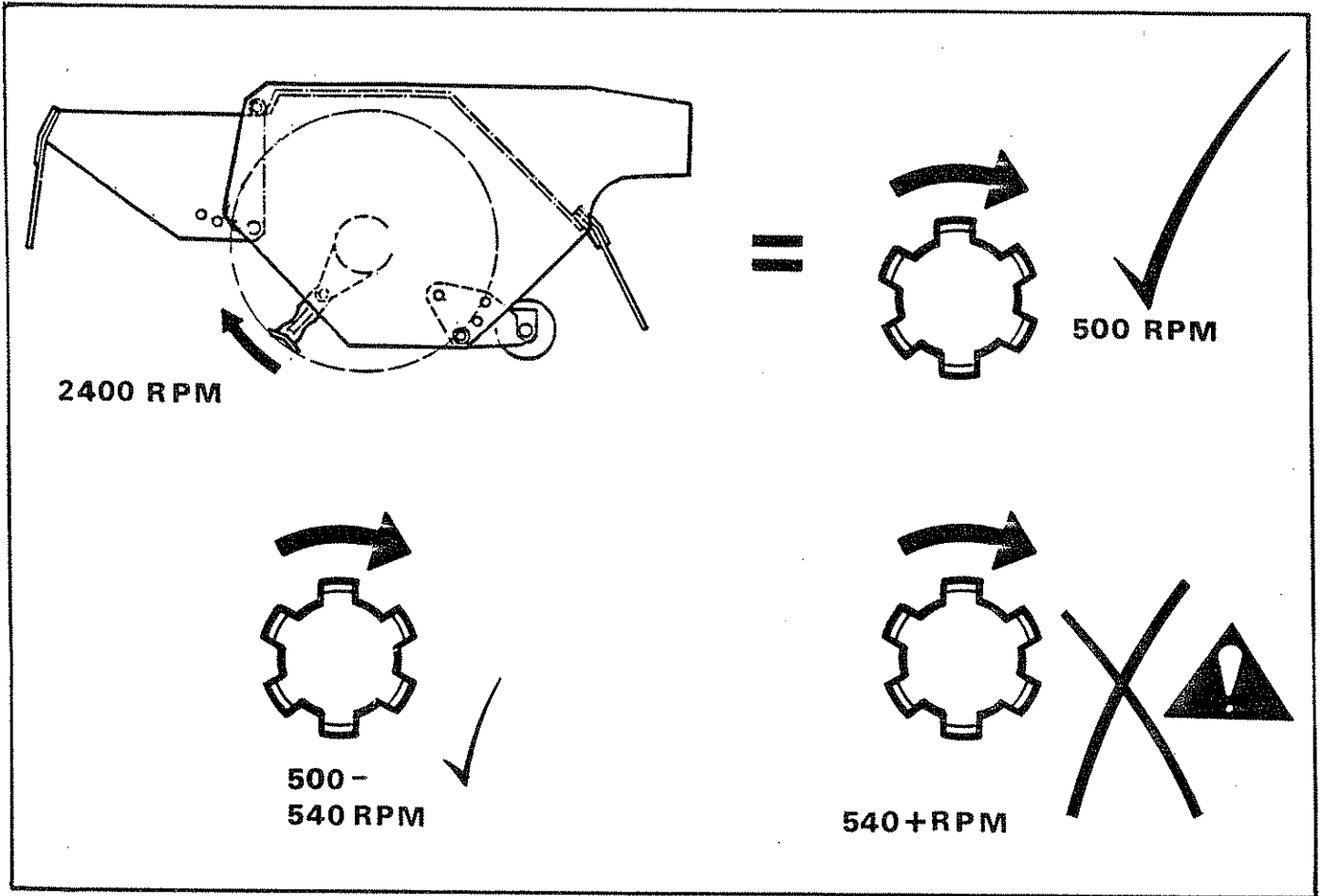

TRACTOR FORWARD SPEED

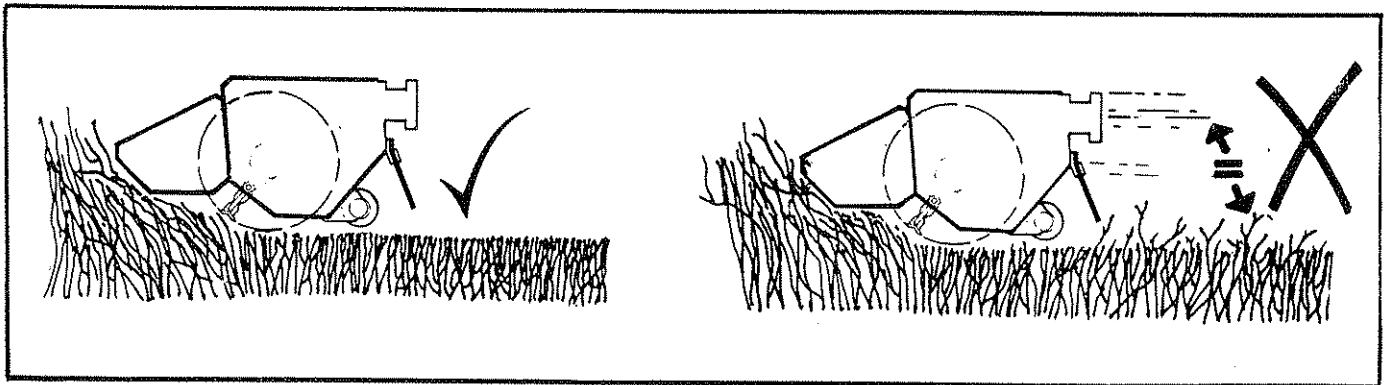

HIGHWAY WORKING

Local highway working regulations must be observed at all times.

**WARNING**

It is the operators responsibility to observe these regulations and to keep bystanders at a safe distance.

## GENERAL WORKING PRACTISES

It is the operators responsibility to develop safe working procedures.

### Always:-

Be aware of hazards in the vicinity.

Make sure all guards are in position and in good condition.

Disengage P.T.O. before stopping the engine.

Wait until the flail has stopped running before leaving the tractor seat.

Disengage the P.T.O. and stop the tractor engine before making any adjustments.

Check frequently that all nuts and bolts are tight.

Keep bystanders at a safe distance.

## CUTTING PRECAUTIONS

Inspect the work area, remove any hazardous material and note any immovable obstructions.

## BREAKAWAY

The pivoted arm is held rigid and in line by the oil pressure in the fully extended breakaway ram. When the flail head meets an obstruction and the tractor continues to move forward oil pressure will build up, against a relief valve situated in the base of the breakaway ram. When the present pressure is reached the valve will blow and the oil will be vented into the lift ram. This will allow the flail head to pivot backwards and at the same time cause the arms to rise. When the obstruction is cleared oil pressure contained in the lift ram will cause the arm and flail head to return to the work position.

CUTTING SEQUENCE

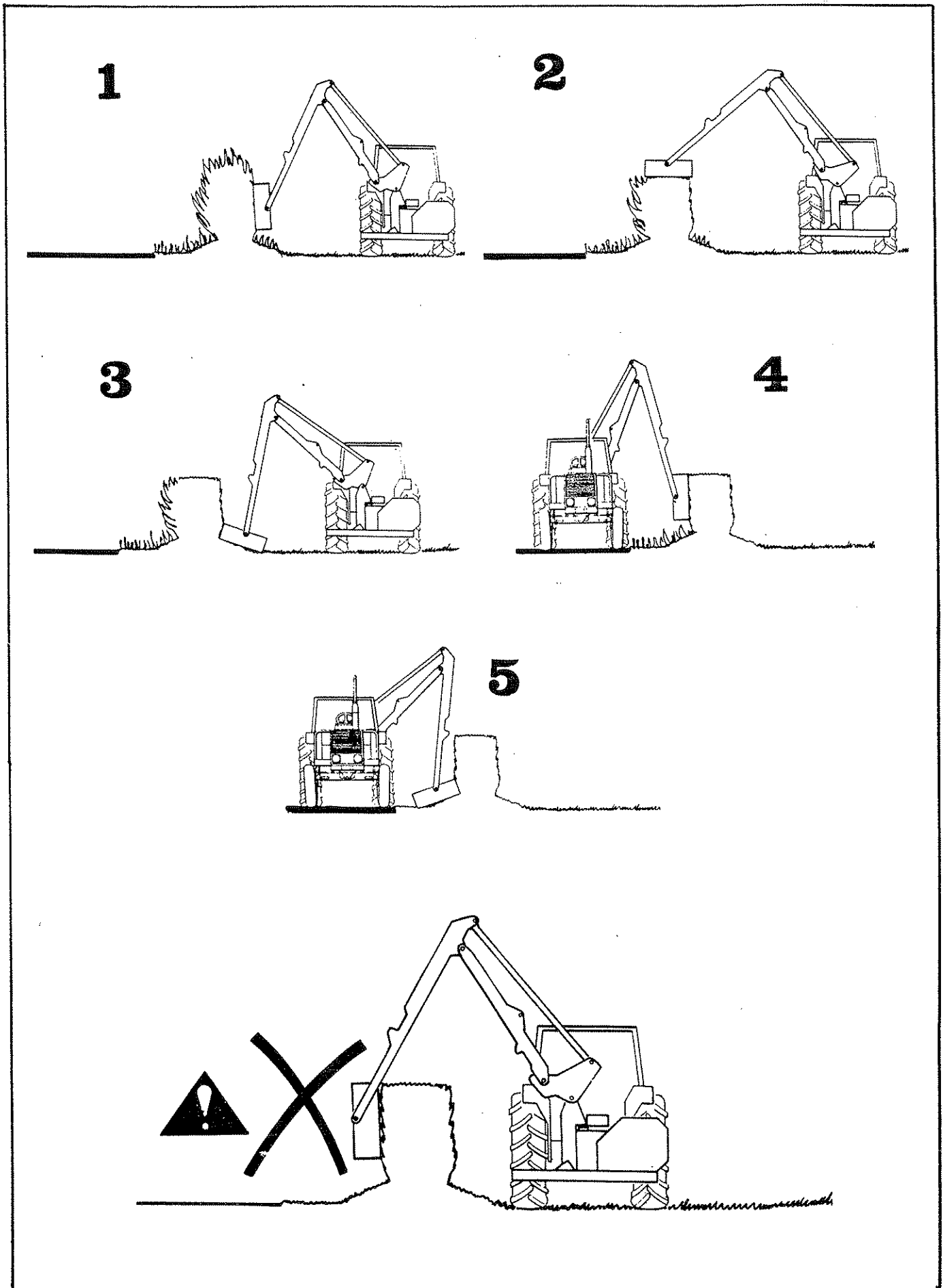



## OVERHEAD OBSTRUCTIONS

Always be aware the machine is approximately 4 metres high when folded and take extra care when manoeuvring in areas with overhead obstacles especially power cables.

## HIGH VOLTAGE CABLES

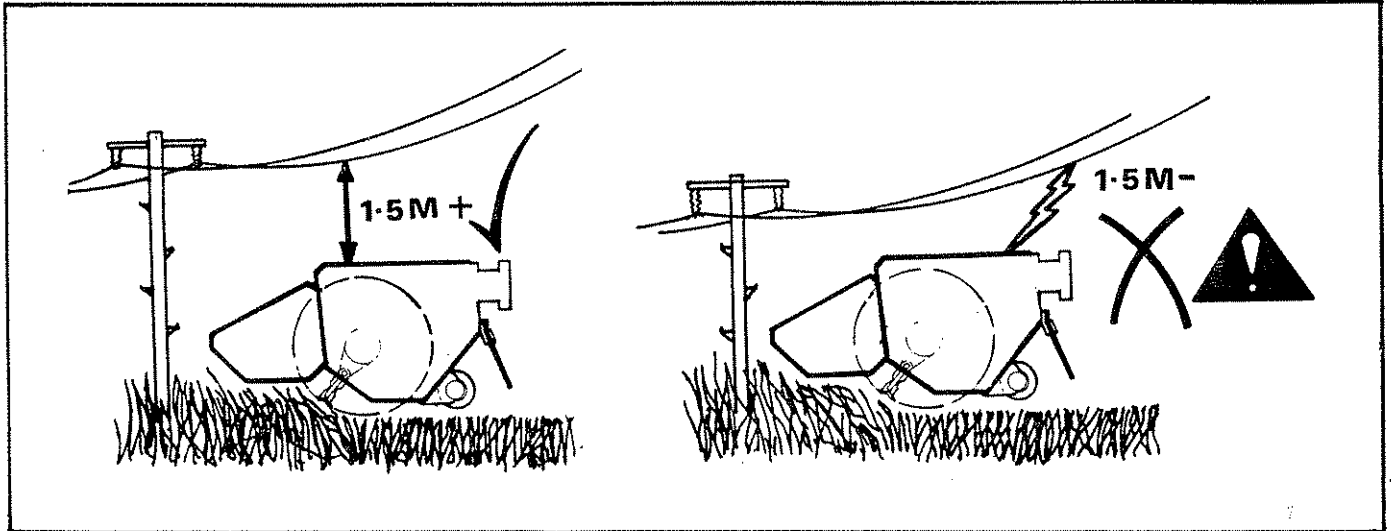

If in doubt consult your local electricity company regarding a safe procedure for work.

## WIRE TRAP

Both flail hoods are equipped with a wire cutting edge welded into the underside. This plate should not be interfered with in any way.

Any wire caught in the rotor must be immediately removed.

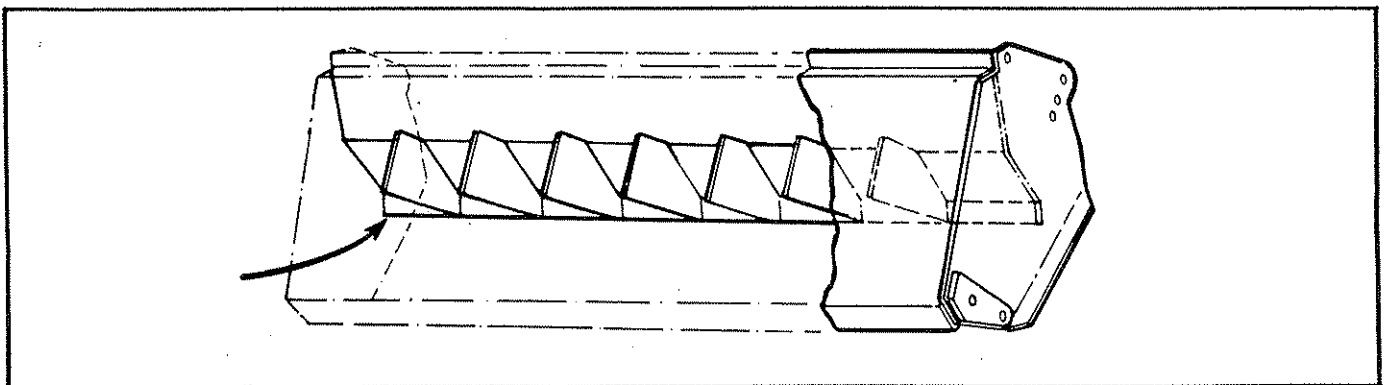

## REMOVING WIRE

Select rotor 'OFF' and wait until it has stopped rotating.

**STOP** the tractor and only then remove wire.

LIFT FLOAT KIT (Optional extra for ground cutting)

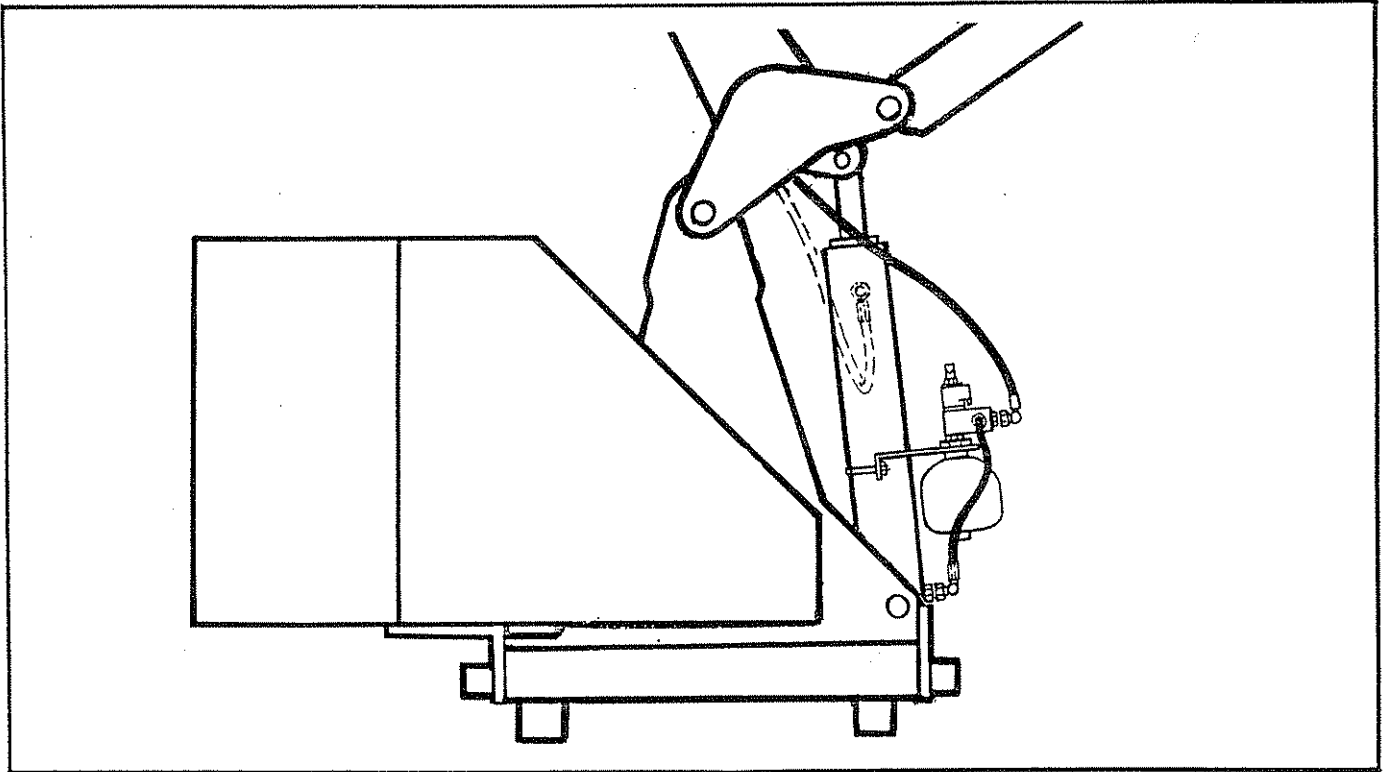

The hydraulic float kit should be mounted as shown clamped to the lift ram barrel in such a position that it does not foul any other component during work

On cable controlled machines the switch is mounted in a convenient location in the cab. The supply cable from the poppet valve solenoid is connected into the tractors ignition system. The brown lead is positive and the blue is negative.

On electric controlled machines the cable from the poppet valve solenoid is connected to the auxiliary switch on the control unit. On multi lever switchboxes the auxiliary switch is a three position type which will allow the selection of head float alone or head and angle float in unison, if both options are fitted.

In work with the poppet valve open the flail head will automatically follow the ground contours.

The float action is engaged either:-

By selection of the auxiliary switch

Or by manually lifting the knurled plunger on top of the poppet valve out of the V groove and rotating through 90 degrees

The lift control should be operated to take a proportion of the flail head weight off the flail roller. This is important, too little weight on the roller will leave uncut areas of grass while with too much weight on the roller the ground will be scalped in places and increased flail wear, damage, or even loss of flails could occur.

To revert to standard operation the accumulator is isolated from the lift ram by deselecting the float switch or by returning the knurled plunger to the 'off' position.

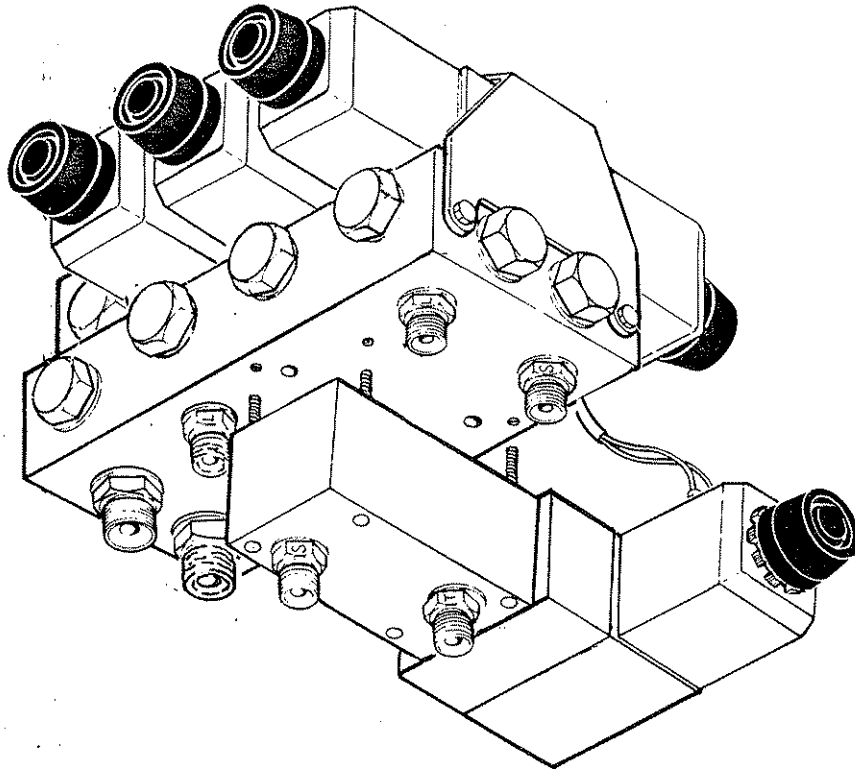

HEAD ANGLE FLOAT KIT - Optional extra on all electric controlled models.

This facility will allow the flail head to angle itself automatically to suit the contours of the ground. It is activated by selecting B

The kit is bolted in position as shown. The existing 'O' rings from the hose plate must be extracted carefully and re-used.

The two core cable is connected from the solenoid to the common link harness and connection 14 on the main harness.

When working with head angle float the flail head mount must be positioned such that the flail head is balanced about the mounting position. Failure to observe this will result in a poor untidy cut.

## MAINTENANCE

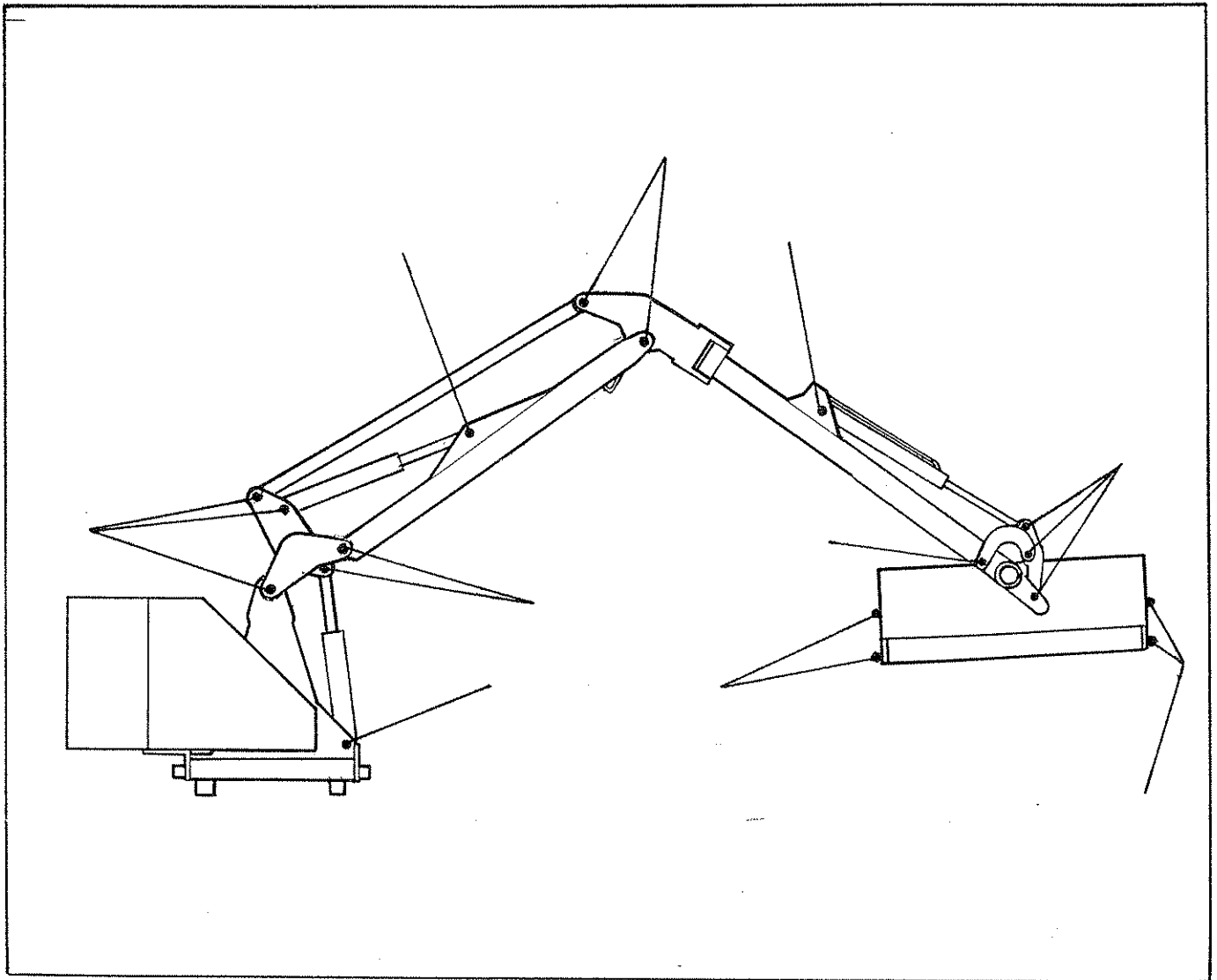

### LUBRICATION

#### General

Grease daily all points shown.

#### Power take-off shaft

The P.T.O. shaft and its guards should be regularly examined. The universal joints should be greased very sparingly i.e. one shot weekly.

Note: Overgreasing a universal joint will blow-out the cork or neoprene sealing rings that exclude the dirt from the needle bearings inside.

The two halves of the plastic guard should be checked daily to ensure that they can spin freely on the shaft. The nylon slip rings which support the guard on the drive shaft should be lightly greased at weekly intervals.

The telescopic drive shaft should be similarly separated and grease applied to the internal shaft at approximately 100 hour intervals.

## HYDRAULIC SYSTEM

### Oil supply

Check the oil level in the reservoir daily.

No fixed time period can be quoted for oil changes as operating conditions and maintenance standards vary so widely. Burnt and scorched oil odours and the oil darkening and thickening are all signs of oxidation and indicate the oil should be changed.

Moisture which results from condensation can become entrapped in the oil and cannot be removed by filtration so that water contamination is progressive.

Contamination can be reduced by:-

- 1) Cleaning around the reservoir cap before removal, and keeping that area clean
- 11) Using clean containers when replenishing the system
- 111) Regular servicing of the filtration system.

### Filtration Maintenance

The machine is protected by a 125 micron suction strainer and a low pressure 10 micron full flow return line filter.

- 1) Suction strainer

The strainer is permanently fixed within the reservoir.

Should symptoms of pump cavitation or spongy intermittent operation occur the tank must be drained and flushed out with a suitable cleaning agent eg. clean diesel oil

- 11) Return Line Filter

The elements should be changed after the first 50 hours and thereafter at 500 hour intervals. It is important to note hours worked as if the filter becomes blocked an internal by-pass within the canister will operate and no symptoms of filter malfunction will occur to jog your memory.

## P.T.O. GEARBOX

The gearbox is rigidly bolted on to the main frame and has a filler plug. Oil level is correct when level with the filler plug aperture. The gearbox oil should be changed every year or at 600 hour intervals: whichever occurs first. The capacity of the gearbox is .25 litres (1/2 pints) of suitable light gear oil.

## HYDRAULIC HOSES

The condition of all hoses should be carefully checked during routine service of the machine. Hoses that have been chafed or damaged on their outer casing should be securely wrapped with waterproof adhesive tape to stop the metal braid from rusting. Hoses that have suffered damage to the metal braid should be changed at the earliest opportunity.

### Hose replacement

- a. Replace one hose at a time to avoid the risk of wrong connections.
- b. When the hose is screwed to an additional fitting or union, use a second spanner on the union to avoid breaking both seals.
- c. Do not use jointing compound on the threads.
- d. Avoid twisting the hose. Adjust the hose line to ensure freedom from rubbing or trapping before tightening hose end connections.

Before changing hoses study the installation these are carefully calculated to prevent hose damage during operation. Always replace hoses in exactly the same manner. This is especially important for the flail hoses where they must be crossed, upper to lower, at the dipper and head pivots.

## CABLES

The cables operate on a push/pull system with the spool centering springs always returning the spool to the neutral position when the handle is released.

Care should be taken during installation and operation to ensure that the cables are not trapped or kinked. Any abrasion or damage to the outer casing should be sealed with plastic insulation tape to avoid moisture penetrating.

No routine adjustment of the cables are necessary as they do not stretch. The threaded collar is correctly adjusted when the lever is in a vertical position in its housing allowing an equal amount of travel in either direction.

**CAUTION** On no account should any attempt be made to lubricate the cables which are assembled with a special lubricant during manufacture.

**NOTE** Take care to ascertain the correct cable connections on both the control unit and the valve in the event of cable replacement.

# HOSE CONNECTIONS

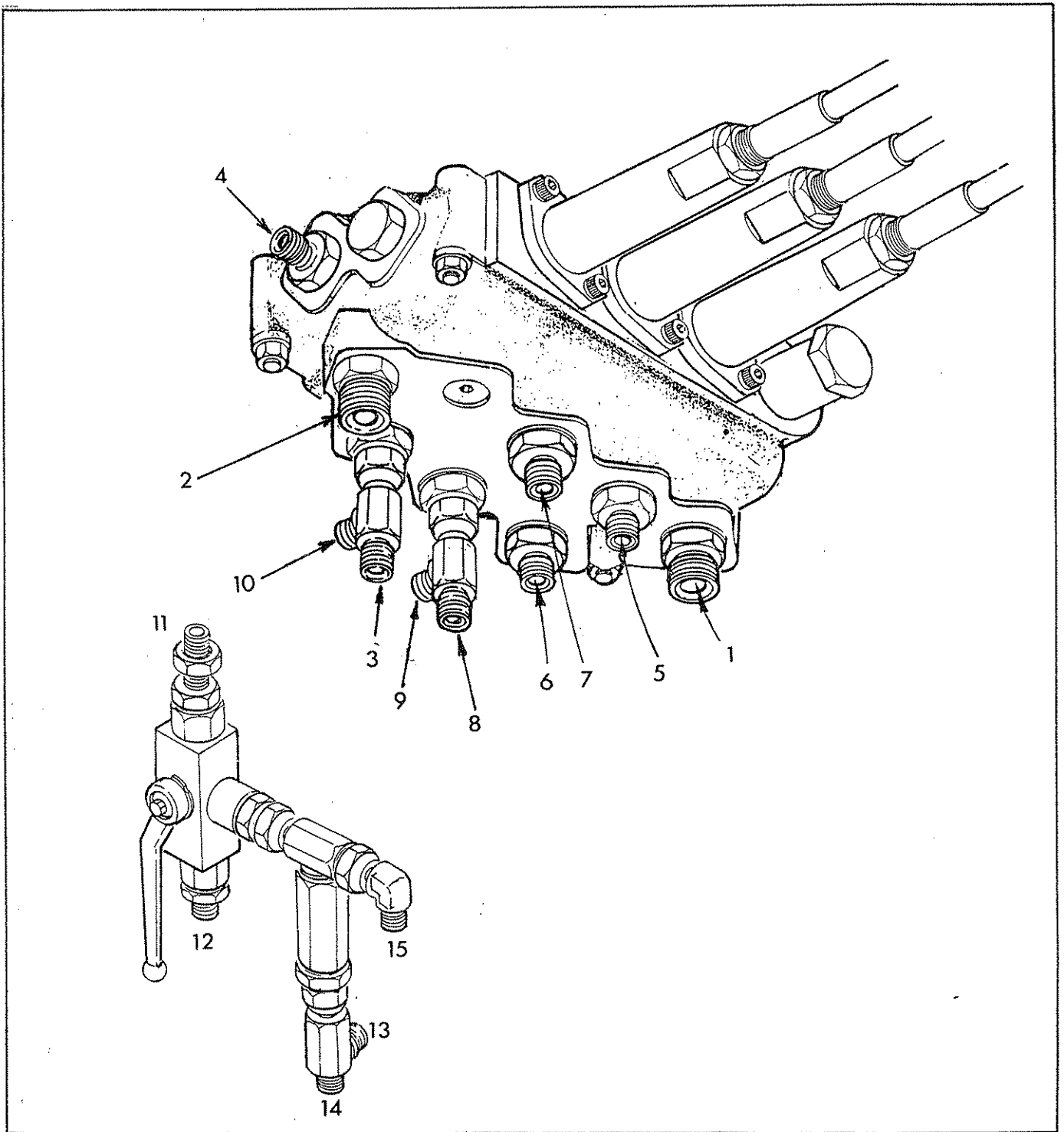

- |   |               |    |                |
|---|---------------|----|----------------|
| 1 | Supply        | 8  | Angle gland    |
| 2 | Return        | 9  | Connection 12  |
| 3 | Lift base     | 10 | Connection 11  |
| 4 | Connection 13 | 11 | Connection 10  |
| 5 | Reach base    | 12 | Connection 9   |
| 6 | Reach gland   | 13 | Connection 4   |
| 7 | Angle base    | 14 | Lift gland     |
|   |               | 15 | Breakaway Base |



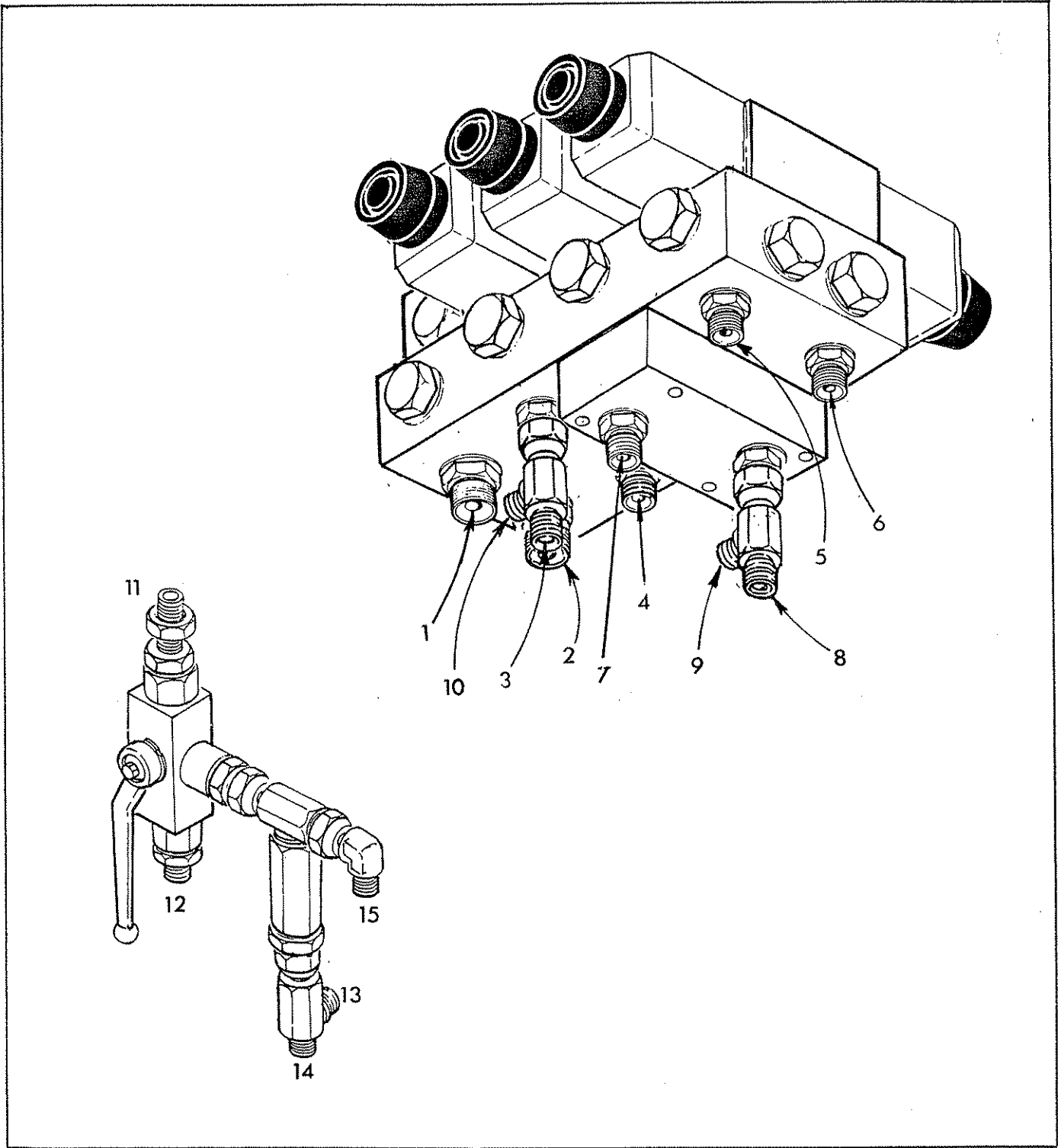

- |   |               |    |                |
|---|---------------|----|----------------|
| 1 | Supply        | 8  | Angle gland    |
| 2 | Return        | 9  | Connection 12  |
| 3 | Lift base     | 10 | Connection 11  |
| 4 | Connection 13 | 11 | Connection 10  |
| 5 | Reach base    | 12 | Connection 9   |
| 6 | Reach gland   | 13 | Connection 4   |
| 7 | Angle base    | 14 | Lift gland     |
|   |               | 15 | Breakaway Base |

ROTOR CONTROL VALVE - All totally independent machines

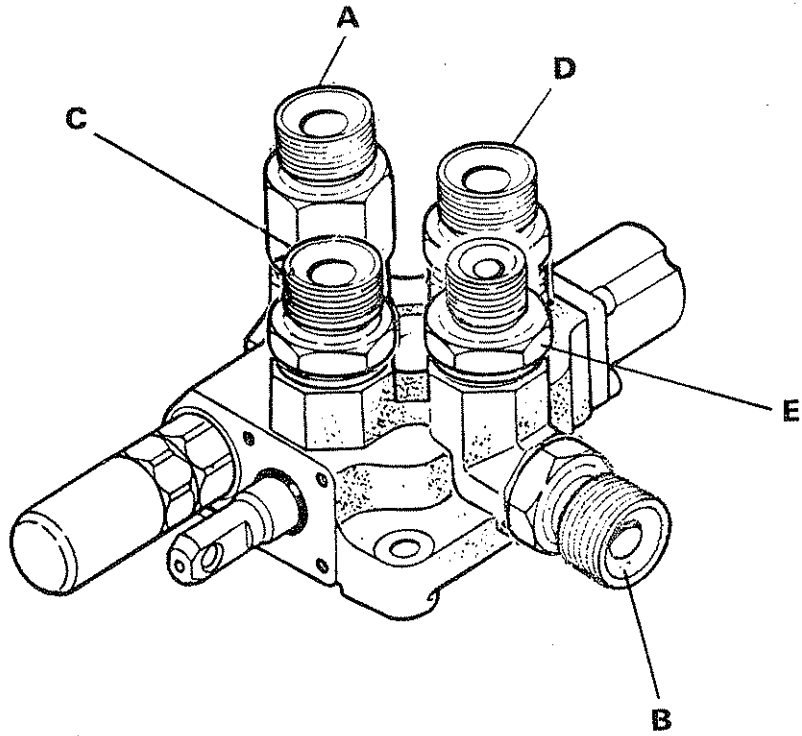

ROTOR RELIEF VALVE - All semi independent machines

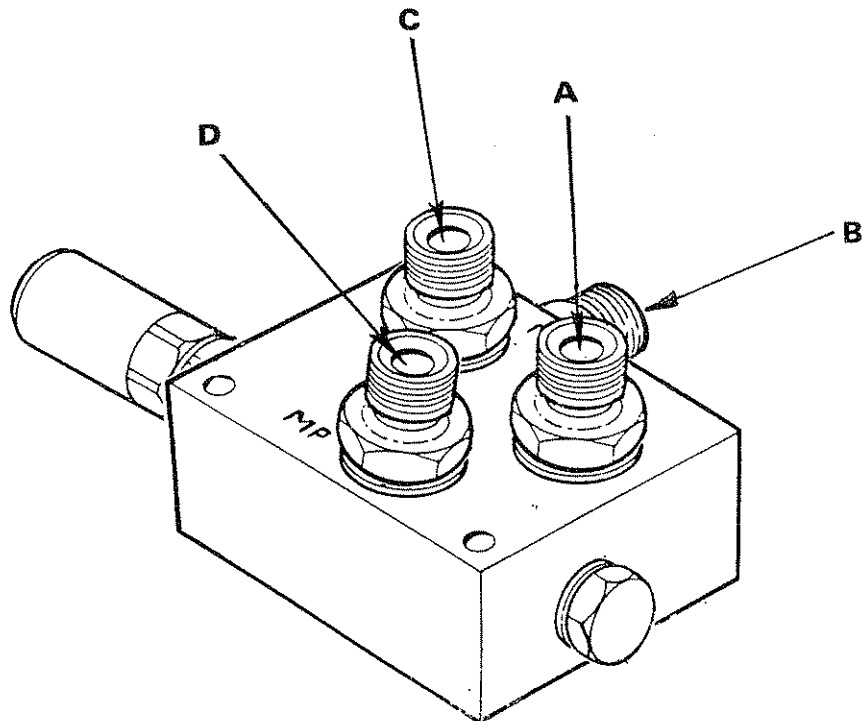

- |                             |                    |
|-----------------------------|--------------------|
| A - Supply from pump        | B - Return to tank |
| C - Motor upper             | D - Motor lower    |
| E - Return from main valve. |                    |



McConnel Limited, Temeside Works, Ludlow, Shropshire SY8 1JL. England.  
Telephone: 01584 873131. Facsimile: 01584 876463. [www.mcconnel.com](http://www.mcconnel.com)