

PA 27 & PA 31

Operator & Parts Manual

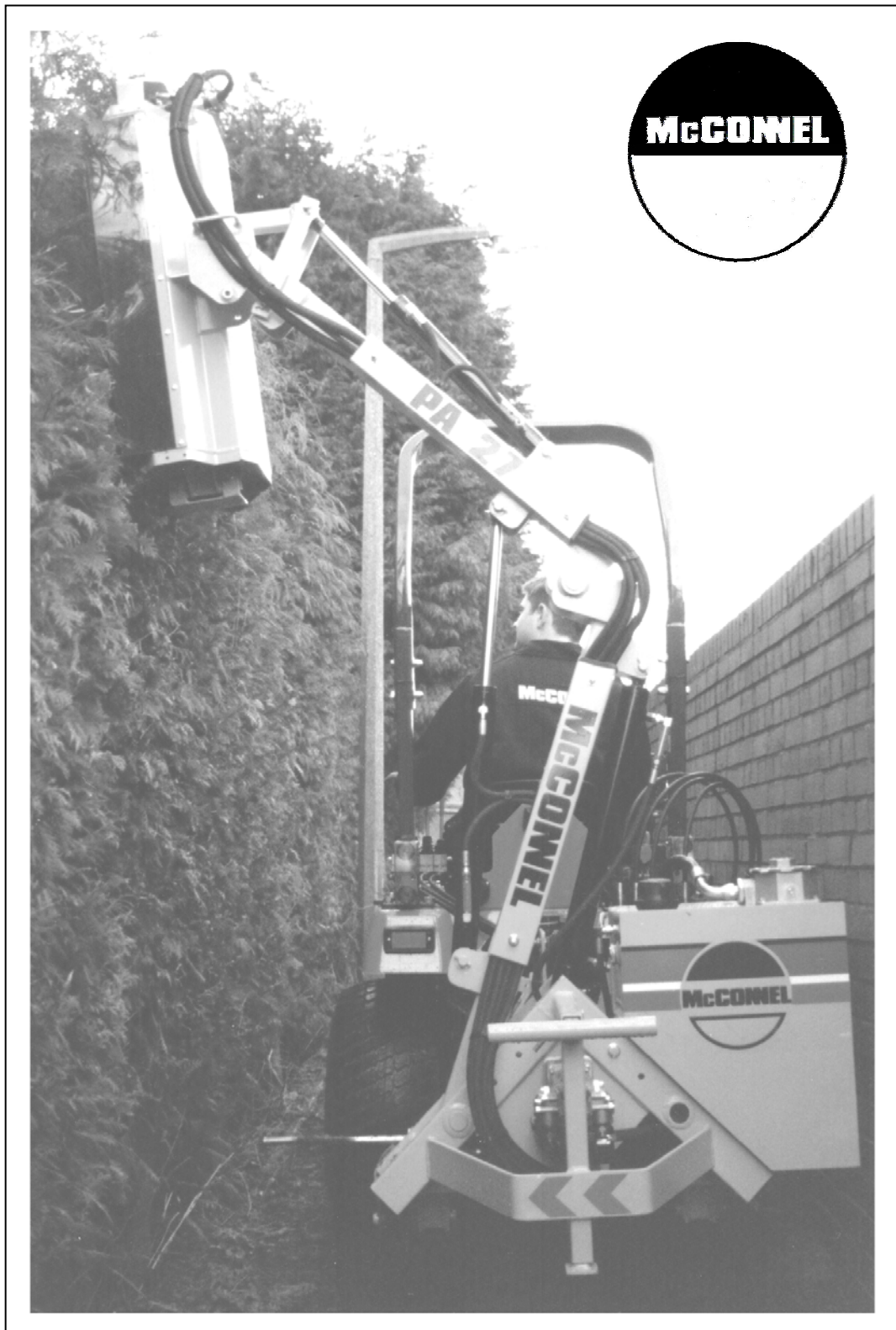

IMPORTANT

VERIFICATION OF WARRANTY REGISTRATION

(Applies to UK Machines only)

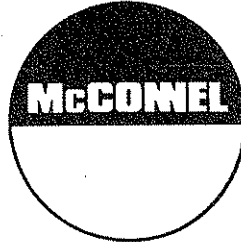

UK DEALER WARRANTY INFORMATION & REGISTRATION VERIFICATION

It is imperative that the selling dealer registers this machine with McConnel Limited within 7 days of delivery to the end user – failure to do so may affect the validity of the machine warranty.

To register a machine go to the McConnel Limited web site at www.mcconnel.com, log on to 'DEALER INSIDE' and select the 'Machine Registration button' which can be found in the Service Section of the site. Confirm to the customer that the machine has been registered in the section below.

Should you experience any problems registering a machine in this manner please contact the McConnel Service Department on 01584 875848.

Registration Verification (UK Machines)

Dealer Name:
Dealer Address:
Customer Name:
Date of Warranty Registration:/...../..... Dealer Signature:

NOTE TO CUSTOMER / OWNER

Please ensure that the above section above has been completed and signed by the selling dealer to verify that your machine has been registered with McConnel Limited.

EC DECLARATION OF CONFORMITY

*Conforming to EEC Machinery Directive 98/37/EC**

We,

McCONNEL LIMITED,

Temeside Works, Ludlow, Shropshire SY8 1JL.

Declare under our sole responsibility that:

The product (type) *Tractor Mounted Trimmer*

.....

Product Code *PA27, PA31*

Serial No. & Date Type

Manufactured by the above company/*

.....

(insert business name and full address if not stated above)*

Complies with the required provisions of the Machinery Directive 98/37/EC, * previously Directive 89/392/EEC as amended by Directives 91/368/EEC, 93/44/EEC and 93/68/EEC.

The machinery directive is supported by;

- BS EN ISO 12100:2003 Safety of Machinery. This standard is made up of two parts; Part 1 Terminology, methodology, Part 2 Technical Specifications.
- BS EN 1050 Safety of machinery - Principles of risk assessment.
- and other national standards associated with its design and construction as listed in the Technical File.

The Machinery Directive is fully implemented into UK law by means of the Supply of Machinery (Safety) Regulations 1992 (SI 1992/3073) as amended by The Supply of Machinery (Safety) (Amendment) Regulations 1994 (SI 1994/2063).

Signed *John Frank*

on behalf of McCONNEL LIMITED

Responsible Person

Status: Chief Design Engineer

Date: 25th January 2005

READ THE BOOK FIRST

It might save hours and pounds later !

When ordering spare parts always quote

- ***The Machine Type***
- ***The Machine Serial Number***
- ***The Part Number***

*Factory re-built service exchange units of
the major hydraulic components are
available from your Dealer*

NOISE

The equivalent daily personal noise exposure from this machine, measured at the operators' ear, is within the range 78 – 85 DB.

These figures apply to a normal distribution of use where the noise fluctuates between zero and maximum. The figures assume that the machine is fitted to a tractor with a quiet cab with the windows closed in a generally open environment. We recommend that the windows are kept closed.

With the cab rear window open the equivalent daily personal noise exposure will increase to a figure within the range 82 – 88 DB.

At equivalent daily noise exposure levels of between 85 and 90 DB, ear protection is recommended, it should be used if any window is left open.

THIS MANUAL IS TO BE HANDED TO
THE CUSTOMER BEFORE THE MACHINE
IS TO BE USED FOR THE FIRST TIME

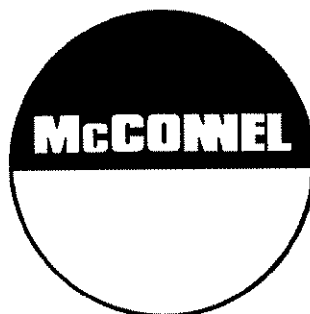

McCONNEL LIMITED

Temeside Works

Ludlow

Shropshire

SY8 1JL

TELEPHONE: 01584 873131

FACSIMILE: 01584 876463

All dimensions and capacities mentioned in this book are approximate. In pursuance of the Companies policy of constant development, the right is reserved to depart, without notice, from any detail illustrated or specified in this book, without incurring the obligation to provide such modifications on machines previously delivered.

No responsibility will be accepted by McConnell Limited for any injury, damage or loss arising from the improper use or lack of maintenance of any machinery supplied by them or from any failure of the user to comply with all instructions published by Tractor or Loader manufacturers, particularly with regard to maximum load capacities, tyre pressures and stability, or with instructions and regulations pertaining to Tractor Cabs.

RAM IDENTIFICATION

When ordering **SEAL SETS, RAM PARTS ETC**, please follow the simple guidelines below to ensure receipt of **COMPATIBLE PARTS**.

Examine the Ram in question at the GLAND NUT. It will be one of THREE TYPES.

TYPE 'A'

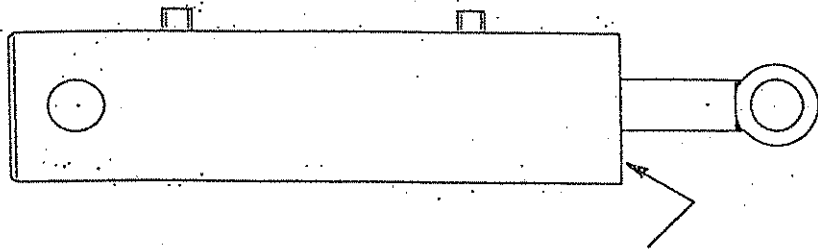

Gland nut internal and flush

TYPE 'B'

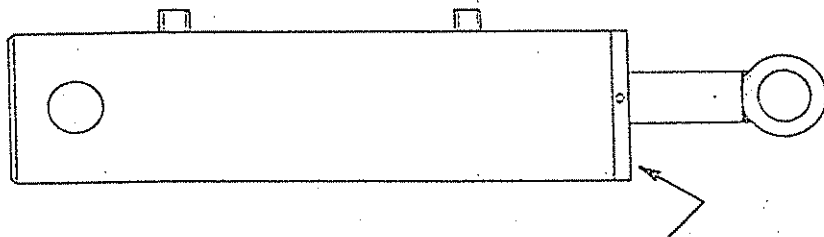

Gland nut exterior and same diameter as cylinder

TYPE 'C'

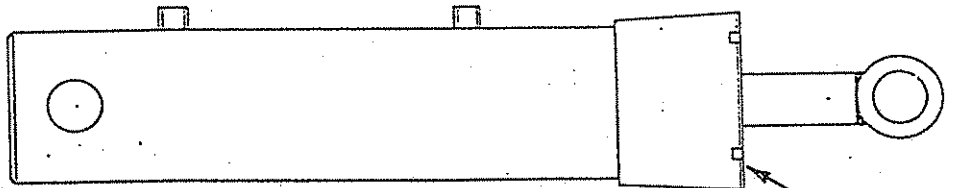

Gland nut is 'large cast Collar type'

WHEN ORDERING PARTS STATE WHETHER TYPE 'A', 'B' OR 'C'

This does NOT apply when a COMPLETE RAM is required, since all ram types are FULLY INTERCHANGEABLE.

INDEX

RAM IDENTIFICATION	1
INDEX	2
SPECIFICATION	3
GENERAL INFORMATION	4
SAFETY NOTES AND WARNINGS	5
ABOUT THIS MACHINE	6
HEALTH AND SAFETY	7
" " "	8
" " "	9
" " "	10
" " "	11
" " "	12
NOTES	13
GENERAL INSTRUCTIONS	14
" "	15
INTRODUCTION	16
ATTACHING HEDGETRIMMER TO TRACTOR	17
" " " "	18
" " " "	19
TRACTOR SELECTION AND CHARACTERISTICS	20
OPERATION INFORMATION	21
HYDRAULIC CONTROLS CUTTING POSITION	22
HYDRAULIC OIL	23
ROUTINE MAINTENANCE AND LAYING UP	24
HANDLING AND TRANSPORTATION OF MACHINERY	25
PARTS LIST - WARRANTY AND SPARE PARTS	26
SUB-FRAME - TANK AND SUNDRIES	27
" " " " " DRAWING	28
" " " " " "	29
" " " " " DRAWING	30
MAIN BOOM (ETC)	31
" " " DRAWING	32
CUTTING HEAD AND ROTOR	33
" " " " DRAWING	34
HEAD MOTOR 'PORTS'	35
" " " DRAWING	36
VALVE BLOCK AND FITTINGS	37
" " " " DRAWING	38
CABLE CONTROL AND MOUNTING BRACKET AND SAFETY SCREEN	39
" " " " " " " " " DRG	40
HYDRAULIC PIPING DIAGRAM	41
" " " DRAWING	42

SPECIFICATION

2.5M AND 3.0M FLAIL TRIMMER

Overall Height - machine folded for transport (2.5m M/C) = 1.600m
(3.0m M/C) = 1.900m

Overall Width - machine folded for transport (2.5m M/C) = 1.570m
(3.0m M/C) = 1.570m

Overall Length of machine (Less P.T.O Shaft) (2.5m M/C) = 0.750m
(taken from linkage pin hole centre) (3.0m M/C) = 0.750m

Total Weight of machine (2.5m M/C) = 322 Kgs
(3.0m M.C) = 341 Kgs

AIRBORNE NOISE EMISSIONS

The equivalent continuous A - weighted sound pressure level at the workstation (Tractor seat) is 88dB (A). This value was achieved cutting hedges using a Dawe 1405C Sound Meter (BS3489) on a Kubota B1750 tractor without a cab.

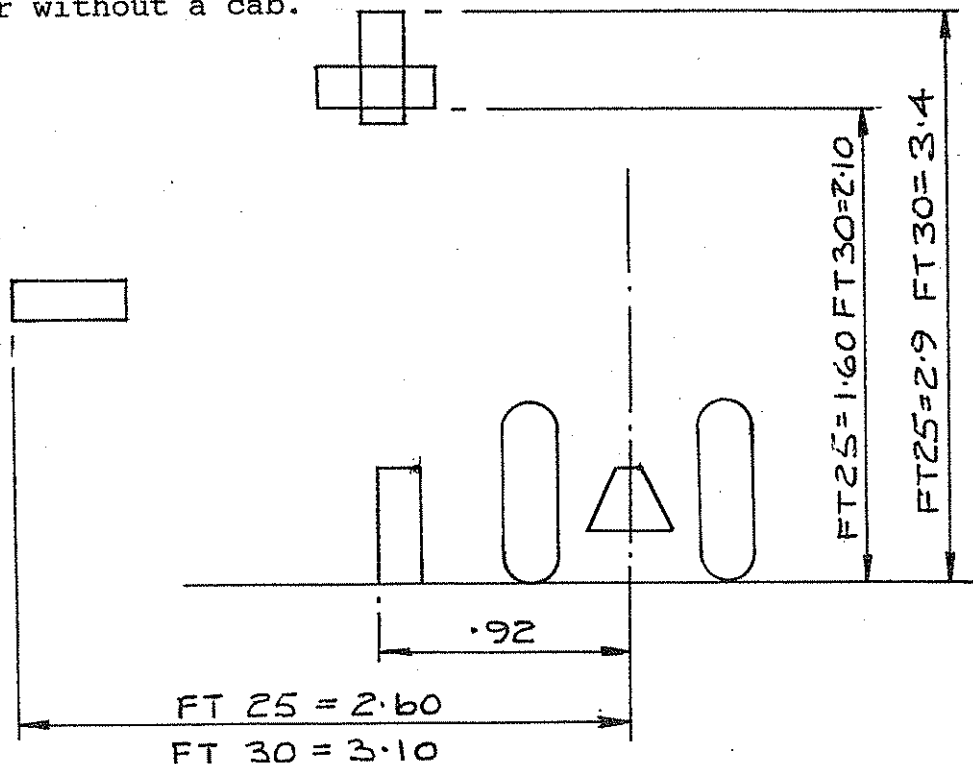

NOTE - All weights, dimensions and details given are approximate and are for guidance only.

GENERAL INFORMATION

NOTE:- The provision of this information is a requirement of the Health & Safety at Work Act 1974.

NOTE:- This handbook has been designed to help the operator and service/mechanic to use and understand the machine fully, safely and efficiently, bearing in mind the Health & Safety requirements and the new CE requirements which come into force from January 1st 1995.

NOTE:- The handbook/manual will be supplied in a waterproof plastic outer cover to prevent damage from rain, condensation etc. The cover of the handbook will include its own part number, which includes information as to machine type and issue date of manual in question.

DANGER

NOTE:-

It is very important that the handbook/manual has been read thoroughly - throughout, and is completely understood before attempting to attach or use machine in any way.

CAUTION: When ordering spares, please state clearly:-

- (a) Machine type and model No.
- (b) Part No. of component.
- (c) Description of component.
- (d) Quantity required.
- (e) Full address to which spares are to be sent.
- (f) Method of delivery required.

CAUTION:- Always insist on genuine and correct spare parts.

NOTE:- Further copies of this handbook/manual can be obtained from:-

McCONNEL LIMITED

Temeside Works

Ludlow

Shropshire

SY8 1JL

TELEPHONE: 01584 873131

FACSIMILE: 01584 876463

SAFETY NOTES AND WARNINGS

Throughout the handbook the following sub headings are used to draw attention to various points of importance.



DANGER
WARNING

This is to draw attention to very important instructions which MUST be followed precisely to avoid injury or death.

CAUTION

This is used to draw attention to instructions which MUST be followed to avoid damage to operator, machine, process or the environment.

NOTE:-

This is used to highlight points used for supplementary information.

ABOUT THIS MACHINE

This is a Hedge Trimmer of the type known throughout the Agricultural Industry as a "Flail Type" Hedgetrimmer.

it is intended to be attached to a compact tractor from 11 kW upwards by means of the "three-point-linkage" couple up system. The addition of an 'A' Frame, which acts as a lock frame ensures a rigid system.

The purpose for its production and its sole intention is to cut/trim hedges, banks, verges etc.

AT NO TIME must this machine be used for anything other than, or to do any job - other than that for which it has been designed (see note above).

HEALTH AND SAFETY



DANGER
WARNING

Never attempt to assemble, couple up, or operate machinery until you understand fully the functions, controls and safety precautions required, as shown in the operators manual.



DANGER
WARNING

Always follow tractor safety operations and instructions VERY carefully.

NEVER TAKE RISKS



DANGER
WARNING

NEVER LEAVE TRACTOR SEAT WHILST ENGINE - OR MACHINE IS RUNNING



DANGER
WARNING

NEVER USE HEDGETRIMMER JIB/BOOM ARMS AS A CRANE IN ANY FORM



DANGER
WARNING

It may be found necessary to stabilise whole unit once coupled together - by ballasting tractor rear wheels and/or fitting counterbalance weights to tractor.

Tractor rear wheels could also be set out to a wider track setting as a method of increasing stability (Check with agent).

CAUTION.

Be aware of warning stickers and instruction stickers on machine as care must be taken and instructions obeyed.

CAUTION

Contact your dealer should you need advice, assistance, or if you do not understand the manual or machine. "NEVER ASSUME" - if not sure - ASK.

CAUTION

Machine MUST NOT be altered or modified in any way - without permission - No liability will be accepted in respect of a machine that has been modified without manufacturers permission.



DANGER
WARNING

Never drive machinery at speeds that could cause danger to other persons or properties, or in a manner that may cause accidents.



DANGER
WARNING

Never attempt to Service/adjust or work on any machinery in an unsupported state.

For Example:- Any three point linkage mounted machinery
Front Loaders
Digger Booms
Hedgetrimmer booms etc. etc.

Always ensure that machinery is safely supported and propped in position.



DANGER
WARNING

Always ensure that the wheels of any wheeled implement/machinery are 'chocked' firmly and implement will not move, before attempting to 'service' or 'work on' in any way or form.

CAUTION

Always "SWITCH-OFF" tractor engine before attempting to carry out adjustment or service repairs and inspections, on machinery.



DANGER
WARNING

Always be aware of your surroundings - and operate machinery accordingly. Beware of confined-tight areas, low height restrictions, buildings and overhangs etc. Also drive and operate bearing in mind weather conditions such as sun, rain, ice, snow, wind etc. [Make allowances in all situations].

CAUTION

Never operate machine in a reckless or uncaring manner. Respect other road users and be patient.

HIGHWAY USE

When operating machinery on the Highways the "Local Highways Department" should be consulted for approval and notification, as rules and regulations vary from local authority area to area.

But the Highways Department regulations must be followed.

NOTE:-

In general it is expected that the "Tractor/implement will follow (WITH) the flow of traffic" - but local Highway rules will confirm this.

Always use 'STOP'-'GO' boards or whatever system Local Highways Department advise, and ensure these are positioned correctly in relation to machine operating area.

Have respect for 'passing' traffic and keep 'passing' lane free from obstruction.

Allow time for walkers and cyclists to clear site. Also when using on the Highway consult the 'Lighting Regulations' for correct procedures.

CAUTION

Never carry "passengers" on machinery or on tractor. Ensure bystanders/onlookers are kept well away from operational area of apparatus.

NOTE:-

NEVER ALLOW ONLOOKERS/BYSTANDERS TO STAND IN FRONT OF CUTTER HEAD - IN LINE WITH FLYING DEBRIS.

A sideways and rearward NO-GO area should also be kept (see sketch below).

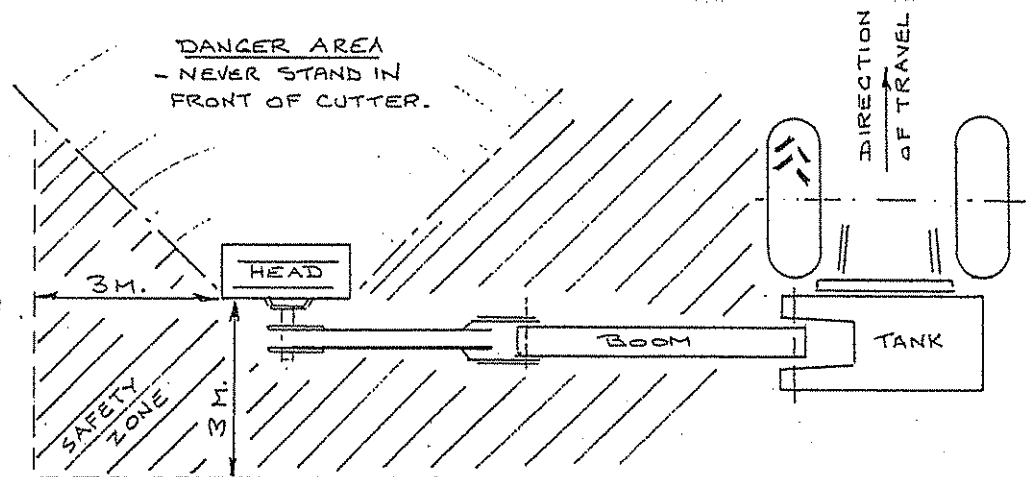

CAUTION

Never operate cutting rotor with blades looking towards operator or towards others.
Cutters must always be operated towards hedge or bank/verge etc.

CAUTION

Never walk underneath the machine for any reason especially if unit is still operation.

CAUTION

'PARKING UP' MACHINE

When machine is being removed from tractor linkage and being 'parked up' it is essential that a good firm base and level site be found.

Always chock and prop machine to ensure a good firm position to leave parked. Ensure that stand legs of machine are correctly locked into position.

CAUTION

Never allow children to play on, or around, parked machinery.

CAUTION

Never wear loose fitting or ragged clothing which could get caught in machinery or controls.



DANGER
WARNING

Always ensure safety screens are fitted into position to protect operator from flying debris.

CAUTION

Ensure visibility is clear through cab-screens at all times.

CAUTION

Ensure workstation controls, joysticks, (Cable levers) etc are positioned correctly to suit operator, and not getting in the way of other driving functions.

Make sure controls do not obstruct entry and exit to cab.

CAUTION

Always dispose of discarded or worn out parts thoughtfully - by disposing of them in an approved and specified legal scrap site, bin or skip.

CAUTION

Worn out and spent waste oil, grease and other obnoxious substances must always be disposed of in suitable and legally approved dumping containers suitable for the waste in question.

CAUTION

Ensure booms are folded onto rubber buffers (which are fitted) and that the whole machine is folded in as close to tractor as possible whilst transporting.

- - - * - - -

CONTROL LEVERS (CABLE MACHINES)
(AUTOMATIC SAFETY)

The control levers which operate the hydraulic boom cylinders on cable control machines will automatically centralise themselves in the CENTRE-OFF position as soon as control lever is let go, thus preventing any chance of unwanted movement or overrun of booms.

JOYSTICK CONTROL (ELECTRIC MACHINE)
(AUTOMATIC SAFETY)

The electronic-proportional control model of Hedgetrimmer, which has a single joystick as controller, will also go automatically to the "CENTRE-OFF" position immediately the joystick is released - cancelling all functions.

[JOYSTICK IS NATURALLY SPRUNG LOADED TO NEUTRAL -
CENTRE OFF POSITION]

- - - * - - -

NOTES

AMENDMENT

DATE

DETAILS

GENERAL INSTRUCTIONS

DANGER
WARNING

1. Before attaching any machine to a tractor or loader make sure that implement is still standing firmly on good solid - level site as it will be, providing unit was previously parked correctly.
-Check that any wheels are 'chocked' correctly and that supports/props are in position where necessary to prevent booms etc. dropping.
2. Before and during the manoeuvring of the tractor or vehicle in order to attach machinery/implements, - make sure that No other persons are in the vicinity.
Keep other persons well clear and make known your intentions, all the while keeping a sharp lookout whilst reversing and aligning machines for coupling up.
3. Always secure tractor into selected position by ensuring that brakes are applied correctly in order to prevent vehicle moving off on its own to cause injury and damage.
4. Make sure that the lift arms and top link ball ends of the tractor are properly fitted to the machine/implement by using correct adaptor sleeves where necessary, and that retaining pins of the correct type are used on all three point linkage points. Secure pins with relevant pin and ring assembly.
5. If the machine is of the drawbar type - check that the hitch on the tractor is in good condition and that the hitch pin used is of the correct size and type, and is properly secured when fitted.
6. Should it become necessary to make any adjustments or service on machine while raised on the tractor linkage, or raised on a front end loader - trestles or suitable supports MUST be positioned to support machine to prevent accidental dropping of lift arms, loader arms or mechanical failure.
[MACHINE MUST ALWAYS BE PROPPED AND CHOCKED]
7. Never attempt to work on, adjust or service repair machinery of any kind whilst it is still running or working. Always stop the machine and STOP THE TRACTOR ENGINE - before any service/repairs begin.
(SWITCH OFF TRACTOR ENGINE BEFORE LEAVING TRACTOR SEAT)

8. In transit always use transport stays or locking devices where provided.
If, as in the case of some longer machines, the unit is transported lengthways - make sure that the front of the tractor is suitably ballasted to maintain stability.
A method of achieving this would be to add suitable weights to a correctly specified and fitted front weight frame.
9. Always use machines in a sensible and reasonable manner and do not attempt to use them in work for which they are not intended. Avoid overloading and abusing them as this can cause damage to machine and tractor and can be very dangerous.
10. When unhitching/detaching a machine from a tractor three point linkage or from a front end loader ensure that any stands or legs are securely positioned and that the machine is parked where it will not be a safety hazard or cause annoyance to others.
Make sure that chose 'parking site' is a firm and level site.
11. Carry out regular periodic maintenance. - Always with safety in mind.
12. Ensure regular maintenance procedures are maintained for the lifetime of the machine.
13. HEALTH AND SAFETY RULES AND REGULATIONS MUST BE ADHERED TO IN ALL AGRICULTURAL RESPECTS.

- - - * - - -

INTRODUCTION

The McConnel PA27 and the PA31 Flail Trimmers are machines designed to fit to the small to medium compact tractors.

The PA27 machine has a reach of approximately 2.5m and is suitable for tractors 11kW (16 HP) plus.

The PA31 machine has a reach of approximately 3.0m and is suitable for tractors 15kW (20 HP) plus.

The two machines have basically common parts and assemblies. The sub frame and cutting head being identical for both size machines as is the hydraulics and system control. The main booms do vary in length (being longer on the 3.0m machine) to give extra reach.

The fixing of Trimmer to tractor is standard 3 point linkage with the addition of an 'A' frame to the linkage which acts as a lock frame.

Only left hand cut machines are available for the UK market.

ATTACHING HEDGETRIMMER TO TRACTOR

1. Select a good level site with sufficient room to manoeuvre tractor and implement.
2. Position tractor on selected site, switch off engine and apply handbrake.
3. Using Flail Hedgetrimmer handle bar (in extended setting) position flail machine behind tractor (move on transport wheels) to such a position that 3 point linkage of tractor and implement are aligned.
4. Move the Trimmer towards tractor and couple up the 3 point linkage. Ensure all linkage pins are located and securing clips are fitted.
5. The 3 point linkage lock 'A' frame should be attached at the same time as 3 point linkage pins are fitted. This 'A' frame has 2 setting positions 'short' and 'long', this can be set prior to actually fitting to tractor and will vary depending on tractor size.

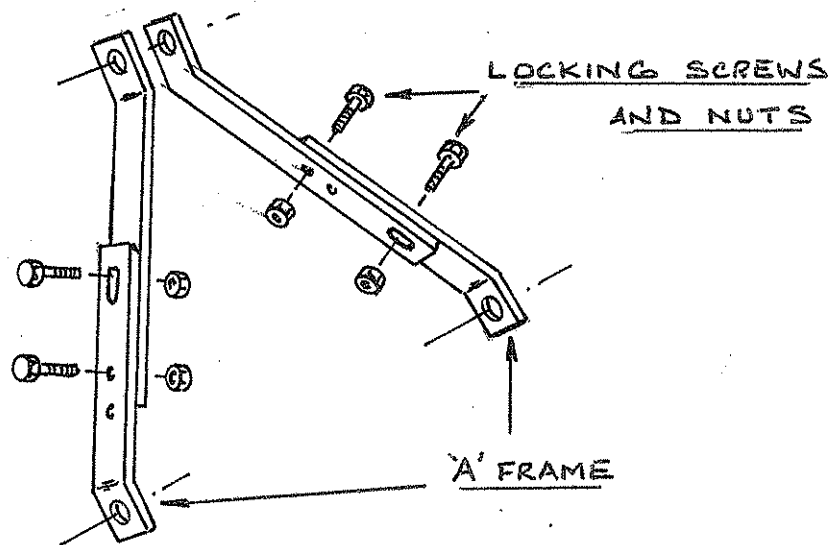

The Four bolts (2 each side) of 'A' frame, once fitted to bars at chosen 'length setting' position MUST be left slack at this stage of assembly.

6. With the linkage now coupled (tractor to implement) raise the trimmer hydraulically on linkage to give a height under transport wheel to floor of 150mm. Ensure linkage 'A' frame chosen setting is correct whilst setting height.

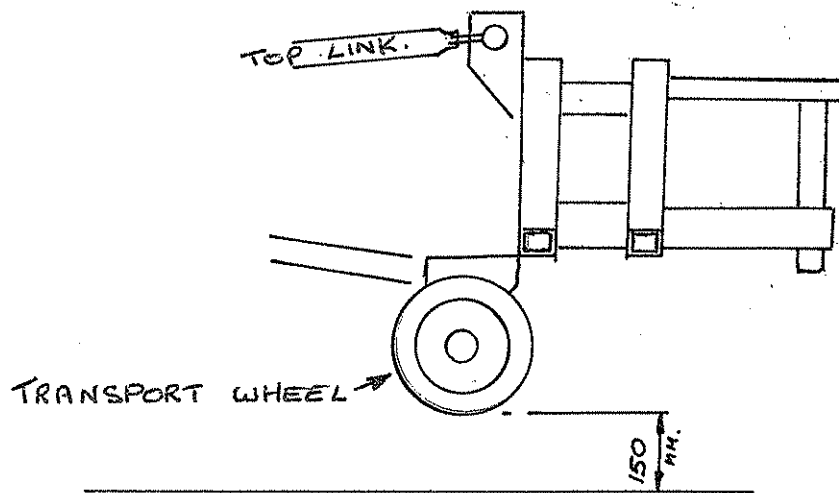

7. Adjust tractor linkage levelling rod to ensure the trimmer is parallel to the ground.
8. Adjust tractor tie rods/check chains to lock lower links ensuring P.T.O on machine is on centre line of tractor.

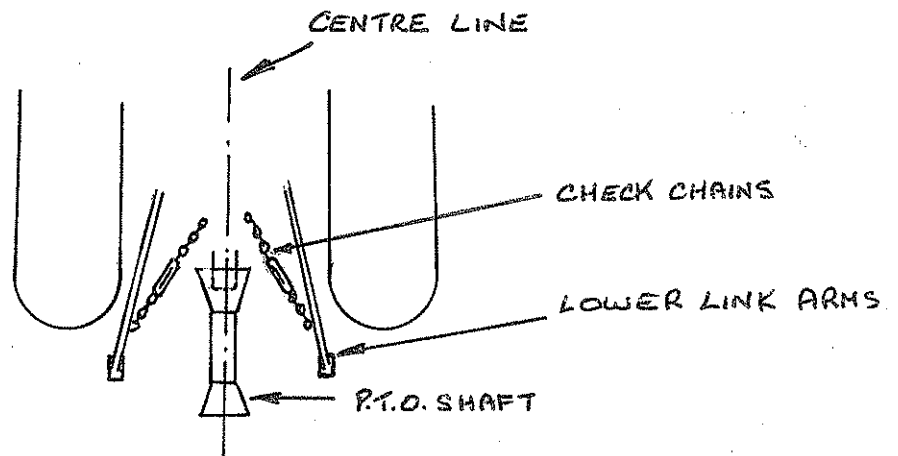

9. Tighten the four bolts through linkage lock 'A' frame (2 each side). This will totally stabilise linkage in required position.
10. Remove parking stand locating pin and clip, raise stand to maximum height setting and replace locating pin and clip at this setting.
11. Remove handle bar locating pin and clip - push handle 'in' to minimum setting, replace locating pin and clip.
12. Move tractor hydraulic linkage control lever to "down" position and lock, this will allow the weight of trimmer to be taken on the now locked 'A' frame and linkage.

13. Couple the P.T.O drive shaft from trimmer to tractor. NOTE - it may be necessary to cut P.T.O shaft and guard to suit individual tractors.

(ENSURE MALE - FEMALE SHAFTS DO NOT BOTTOM)

14. Fit protection mesh screen to all tractors before using.
15. Mount the hydraulic control cables, levers to suit operator.

TRACTOR SELECTION FOR
2.5M AND 3.0M MACHINE
AND CHARACTERISTICS REQUIRED

1. The tractor must be equipped with 3 point linkage attachment facility.

2. The tractor must be equipped with a Power Take Off shaft, which must run at the generally accepted standard 540 r.p.m.

The P.T.O shaft should run clockwise when looking at the rear of the tractor, and ideally should be the 1.3/8 SAE 6 splined shaft enabling standard P.T.O shaft to be fitted.

3. The tractor run-up power should be 11 kW (15 HP) for the 2.5m machine and 15 kW (20 HP) for the 3.0m machine.

FLAIL TRIMMER - OPERATION INFORMATION

The vehicle driver should be conversant with all tractor controls and capabilities.

It is always advisable for the tractor driver to practice the controls and operations of the Flail Trimmer prior to setting off into work.

The speed of operation of Trimming will depend on the size, quantity, and type of growth to be cut. A slow speed to suit the conditions, should be selected, ensuring that engine speed gives a P.T.O speed of 540 r.p.m.

IMPORTANT: Always ensure tractor P.T.O speed is (540 r.p.m) to give correct rotor speeds.

ROTOR ROTATION - DIRECTION:-

Depending on the type of hedge to be cut, an option of rotation direction is offered. The 'Upward' cut is recommended for trimming grass, light growth such as one/two years growth.

For heavier going such as larger sticks and thick untrimmed hedges the rotor must be set of cut 'downwards'. In order for this downward cut to operate the front cowl of Flailhead must be removed.

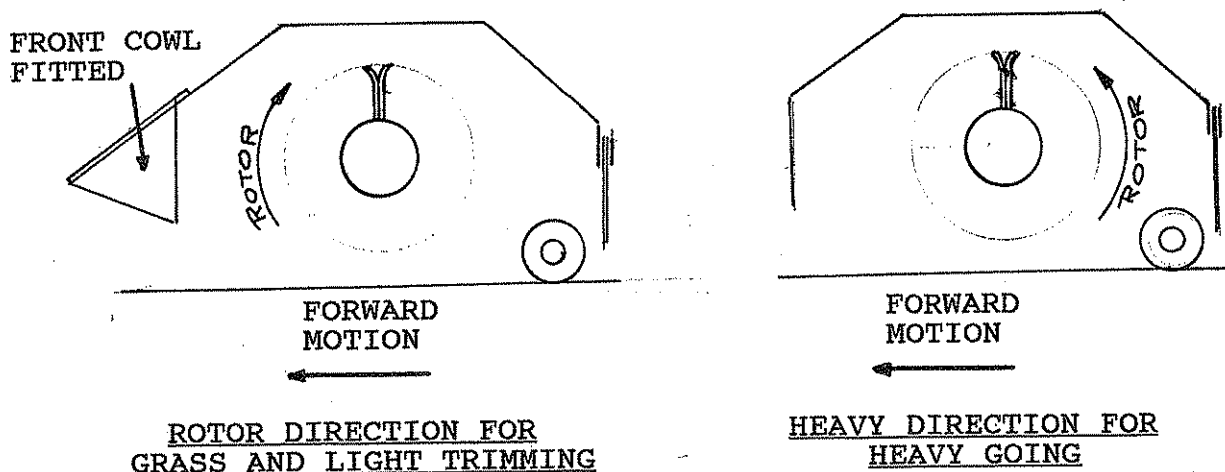

IMPORTANT: For cutting upwards the cutting head front guard **MUST** be fitted.

For cutting downwards the cutting head front guard **MUST** be removed.

HYDRAULIC CONTROLS - CUTTING POSITION

The cutting head must at all times be lowered gently into cut position. Never drop head into hedge at speed.

When cutting at ground level (grass etc.) the head must be lowered gently to give a slight contract pressure of roller to ground.

IMPORTANT: Ensure rotor and roller do not get involved in high obstacle forces such as rocks, stones, stumps etc. Keep rotor away and free from wire, as to entangle wire into rotor is very dangerous and very costly.

Should large obstacles be encountered or wire caught in rotor STOP IMMEDIATELY. Reset or clear before starting.

Normal obstacles and level variations should be overcome by operator by slowing 'forward motion' and raising/lowering the booms of trimmers to suit.

CUTTING HEAD

The cutting head rotor has been balanced prior to fitting, this will ensure a vibration free cutting unit.

Should the rotor become blocked for any reason, hit an obstacle, loose a blade or blades, the rotor may be put into a state of unbalance. This will result in vibration from the rotor being transmitted through the head.

Should this happen STOP IMMEDIATELY, as to continue could have serious consequences.

Once stopped clean rotor and check for loss of blades and bolts, replace as required.

Insecure cases and as a result of hitting solid objects with serious force the rotor can be bent, this will obviously cause vibrations. In such cases the only answer will be to get rotor repaired/rebalanced or replaced.

HYDRAULIC OIL

It is advisable NEVER to mix hydraulic oils but if another supplier oil is to be used a suitably compatible oil must be chosen (check with Oil supplier).

TANDEM PUMP - GEARBOX

The Hydraulic Gearbox will be fitted with S.A.E E.P 90 oil and this grade must be ensured when topping up "check oil level every 1200 hours".

ROUTINE MAINTENANCE
AND LAYING UP

DAILY



DANGER
WARNING

Check oil level in main system oil tank.



DANGER
WARNING

Grease pivot points regularly.



DANGER
WARNING

Keep the cutting blades VERY SHARP - daily inspection is required here.

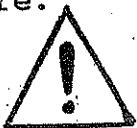

DANGER
WARNING

Check all nuts and bolts for tightness.

WEEKLY



DANGER
WARNING

Check all hydraulic fittings and hoses.

LAYING-UP



DANGER
WARNING

Clean the machine and note any damage or repairs needed. Arrange for spares and repairs as required. Prepare machine for next season.



DANGER
WARNING

Fully lubricate the machine totally.



DANGER
WARNING

Store the machine in dry - undercover conditions.

HANDLING AND TRANSPORTATION OF MACHINERY

The unladen weight of this machinery is given in the specification sheet of this book.

A form of lifting gear is required in order to move or handle this machinery safely. The lifting gear can be attached using a chain, rope or strap of sufficient strength, to the positions shown above.

Once the machinery has been moved, ensure that it comes to rest in a safe position. Supports or stay bars may be necessary to ensure stability of the machinery. Make sure the supports/stay bars are used whenever the machinery is transported.

For best performance...

USE ONLY McCONNEL SERVICE PARTS

To be assured of the latest design improvements purchase your 'Genuine Replacements' from the Original Equipment Manufacturer: McCONNEL LIMITED through your local Dealer or Stockist.

Always quote:

- **Machine Type**
- **Serial Number**
- **Part Number**

Design Improvements may have altered some of the parts listed in this manual – The latest part will always be supplied when it is interchangeable with an earlier one.

SUB-FRAME - TANK - SUNDRIES

<u>REF</u>	<u>PART NO.</u>	<u>DESCRIPTION</u>	<u>QTY</u>
A	178.005	Tank	1
B	6967	Filter	1
C	6968	Filter	1
D	1826	Adaptor	1
E	1836	Adaptor	1
F	6978	Hose (Schrader) 3/4" BSP x 3/4"	1
		Hose	
G	6977	Hose (Schrader) 1/2" BSP x 1/2"	1
		Hose	
H	3939	Groverlock M6 x 40	4
J	6966	Level Indicator (Bullseye)	1
K	3082	M12 Nyloc Stiffnut	6
L	3726	M12 x 120 (8.8) Bolt	3
M	2953	M12 x 100 (8.8) Bolt	1
N	0853	7/8" Pin, Chain, Linch Pin and Ring Assembly	2
P	1657	3/4" Pin, Chain, Linch Pin and Ring Assembly	1
Q	0670	3/8" BSP Seal	1
R	0920	3/8" BSP Plug	1
S	178.032	Transport Stay Pin	3
T	2435	'R' Clip	3
U	178.004	Handle	1
V	1181	1/4" Seal	1
W	1823	1/4" x 1/4" BSP Adaptor	1
X	178.054	Spacer for Valve Plate	2
Y	178.031	Transport Stay	1
Z	178.001	Main Frame	1
AA	6979	Flat Washer (M24) Form 'B'	10
BB	6963	Wheel	2
CC	4776	Stiffnut M6 Nyloc	1
DD	6981	M6 x 50 (8.8) Bolt	1
EE	178.028	Head 'Stop' Bar	1
FF	6964	Pedal Rubber	1
GG	178.002	Break Back Link	1
HH	6974	Elbow IGQ12 c/w 'O' Ring	2
JJ	6975	Elbow 2G34 c/w 'O' Ring	1
KK	0909	Seal	2
LL	0934	Seal	1
MM	0914	Adaptor 1/2" BSP x 3/8" BSP	2
NN	6995	Elbow IG12	1
PP	6972	Coupling 2/1	1
QQ	6970	Pump CPL 16	1
RR	6976	Coupling M02/14	1
SS	6962	Gearbox MP2/M/3.8 (1:3.8)	1
UU	3001	M8 Spring Washer	4
VV	2793	M8 x 20 (8.8) Setscrew	4
WW	6971	Pump CPL 4.7	1
XX	6965	Valve Block	1
YY	178.053	Valve Block Plate	1
ZZ	4061	PTO Shaft complete	1
AAA	178.014	Pin (Main Boom, Anchor End)	1

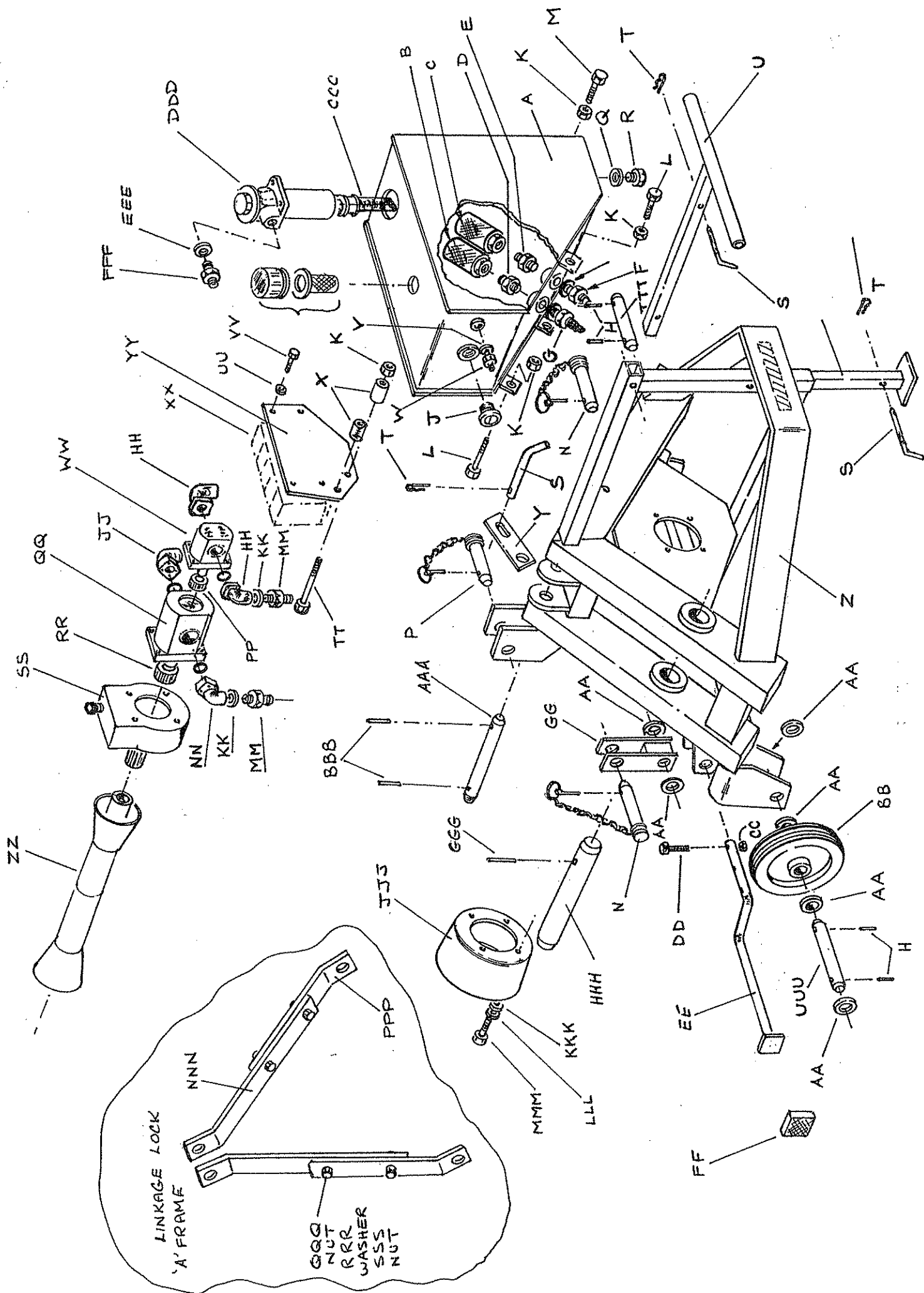

<u>REF</u>	<u>PART NO.</u>	<u>DESCRIPTION</u>	<u>QTY</u>
BBB	3990	Groverlock Pin M6 x 30	2
CCC	178.010	Filter Drop Tube	1
DDD	4924	Filter (UCC)	1
EEE	3155	1 1/4" BSP Seal	1
FFF	5241	Adaptor 1 1/4" BSP x 1" BSP	1
GGG	6960	M8 x 55 Groverlock	1
HHH	178.011	Main Boom Pin	1
JJJ	6385	PTO Guard	1
KKK	3219	M10 Flat Washer	4
LLL	2728	M10 Spring Washer	4
MMM	2709	M10 x 20 (8.8) Flat Washer)	4
NNN	178.030	Stay for Lift Arms	2
PPP	178.029	Stay for Lift Arms	2
QQQ	2720	Nut	4
RRR	2716	Washer	4
SSS	2748	Setscrew	4
TTT	178.021	Axle Pin (Short)	1
UUU	178.020	Axle Pin (Long)	1

NOTE:

6969 Tandem Pump Complete

Comprising:-

6970	Pump (16)	1
6971	Pump (4.7)	1
6972	Coupling	1

NOTE:

Bolts for Pump Elbow:-

For 6970 Pump CPL16:-

6994	M8 x 25 Caphead	4
3001	M8 Spring Washer	4

FOR 6971 Pump CPL4.7:-

6992	M6 X 30 (8.8) Caphead	4
6985	M6 x 45 (8.8) Caphead	4
2731	M6 Spring Washer	8

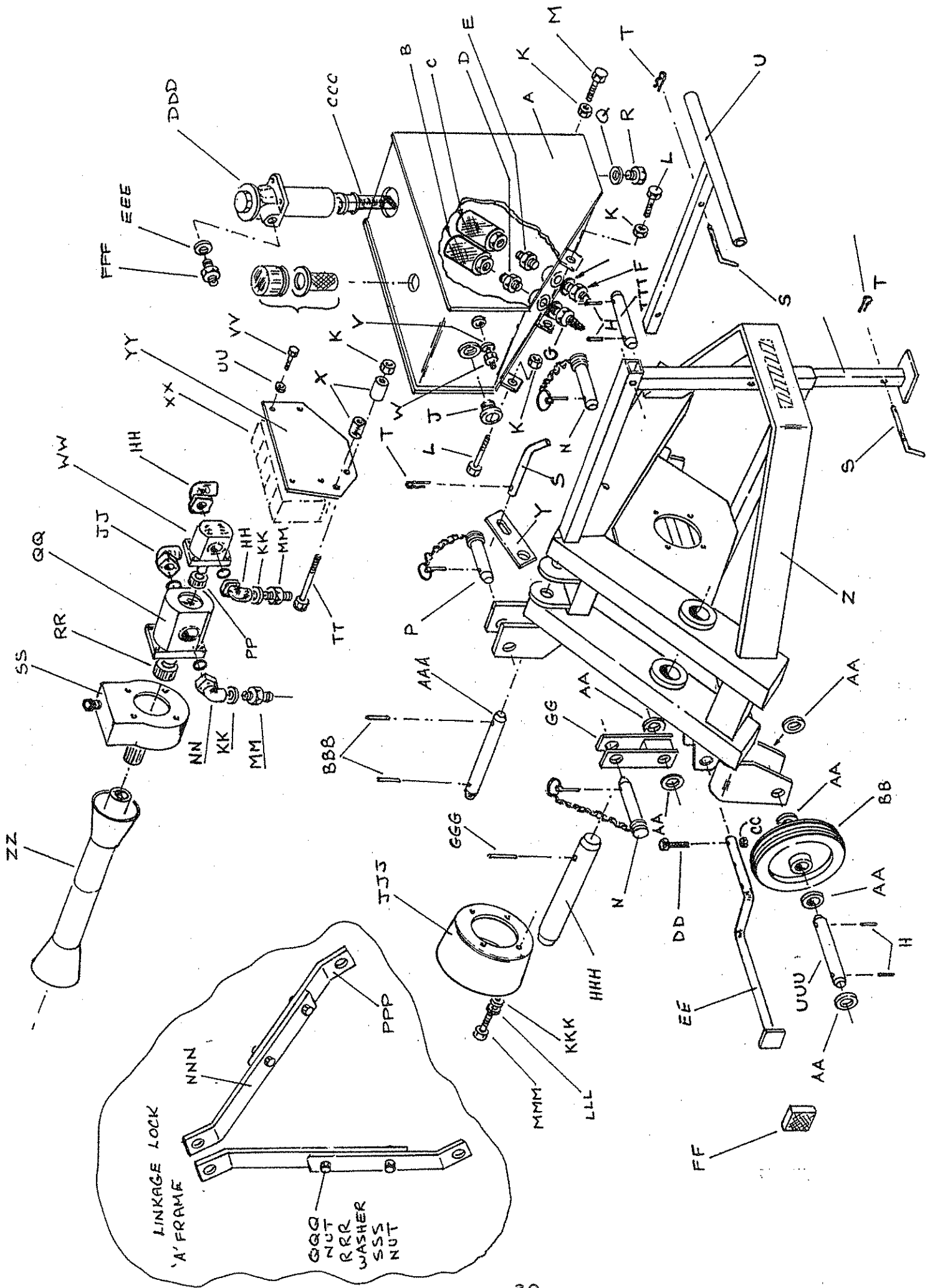

MAIN BOOMS (ETC.)

<u>REF</u>	<u>PART NO.</u>	<u>DESCRIPTION</u>	<u>QTY</u>
A	3939	M6 x 40 Groverlock	9
B	6351	M4 x 30 Groverlock	2
C	6960	M8 x 55 Groverlock	1
D	1180	Adaptor 3/8" BSP x 1/4" BSP	1
E	178.014	Pin	2
F	6979	M24 Washer (Form 'B')	9
G	6956	M6 Straight Grease Nipple	9
H	178.019	Pin	1
J	2716	Washer	1
K	178.008	Head Angling Link	1
L	178.009	Link Plate	2
M	178.017	Pin - Head Angling Ram (Rod)	1
N	178.018	Pin (Link Plate Pivot)	1
P	2716	Washer 12 O Bore	2
Q	178.013	Pin - Second Boom/Head Pin	1
R	6542	Bush 4050M	6
S	178.015	Pin - Main Boom Ram (Rod End)	2
T	178.026	Clamp Plate	2
U	178.027	Clamp Plate	2
V	2732	Stiffnut M10	4
W	178.012	Pin - Main Boom/Second Ram	1
X	1780035	Ram	1
Y	1780034	Ram	1
Z	1780033	Ram	1
AA	178.007	Outer Boom	1
BB	178.006	First Boom	1
CC	178.022	Hose Cover (First Boom)	1
DD	178.023	Hose Cover (Outer Boom)	1
EE	4063	Bolt M10 x 130	2
FF	3139	Bolt M10 x 140	2
GG	4894	Setscrew M6 x 12	8
HH	2731	Washer M6	8
JJ	149.049	Breather c/w 'o' ring	1
KK	6988	3/8" x 3/8" M/F Loosenut Short 90	1
LL	0670	3/8" Seal	2
MM	6986	Restrictor (One Way) (1.5)	1

BOOMS FOR PA31

1st Boom

178.059

2nd Boom

178.060

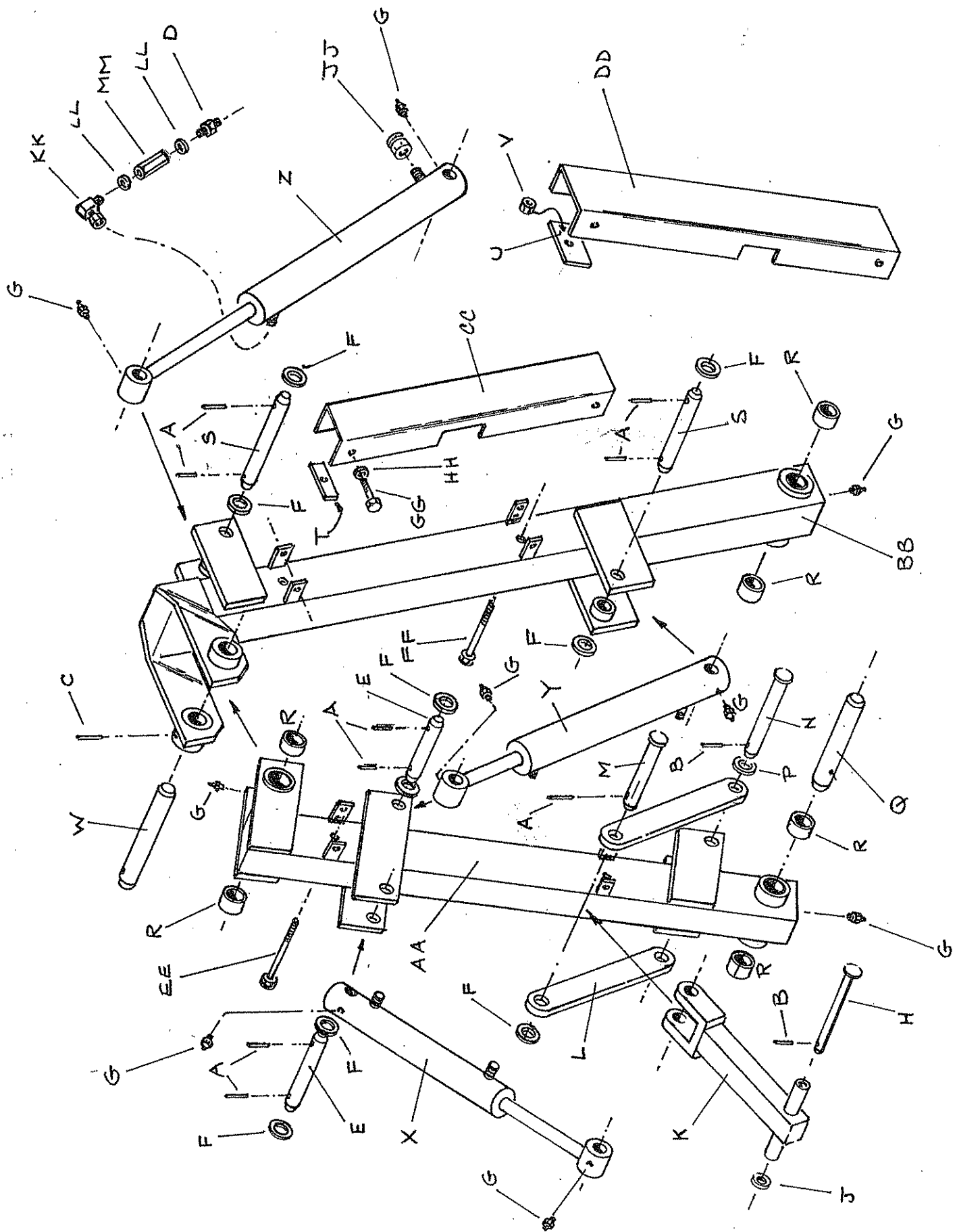

CUTTING HEAD AND ROTOR

REF	PART NO.	DESCRIPTION	QTY
A	6985	Caphead M6 x 45	4
B	2731	Spring washer M6	4
C	6956	M6 Grease Nipple	1
D	2728	Spring washer M6	4
E	2917	M10 x 25 (8.8) Setscrew	4
F	178.041	Motor Mounting Plate	1
G	6957	Circlip (Ext)	1
H	178.046	Special Washer	1
J	6959	Bearing	1
K	178.045	Spacer	1
L	178.044	Bearing End Cap	1
M	178.043	Drive Coupling	1
N	178.040	Head Extension	1
P	5573	Caphead Screw M10 x 20	4
Q	178.048	Rotor	1
R	3183	M8 x 48 (8.8) Bolt	36
S	178.061	Spacer for Shackle	36
T	7558	Stiffnut M8 Binx	36
U	1780037	Shackle	36
V	1780036	Blade	72
W	6958	Bearing	1
X	3082	M12 Stiffnut	4
Y	2716	Flat Washer M12	2
Z	2702	Bolt M12 x 60	2
AA	6961	Head Motor	1
BB	4776	Stiffnut M6 (Nyloc)	17
CC	2707	Setscrew M6 x 20	10
DD	178.047	Motor Guard	1
EE	3122	Setcrew	1
FF	3001	Washer	4
GG	2950	Bolt	4
HH	178.039	Roller Bracket	2
JJ	3730	M8 x 40 (8.8) Setcrew	2
KK	178.051	Bearing Retaining Washer	2
LL	6939	Bearing (6004)	2
MM	178.049	Roller	1
NN	178.050	Roller Axle	1
PP	6398	Circlip (1400/20)	2
QQ	1780055	Curtain	1
RR	178.056	Clamp Strip	1
SS	6960	M8 x 55 Groverlock	1
TT	178.038	Head Assembly	1
UU	2913	Setscrew M6 x 16	7
VV	6980	Circlip 30	1
*	178.066	Rotor End Guard	2

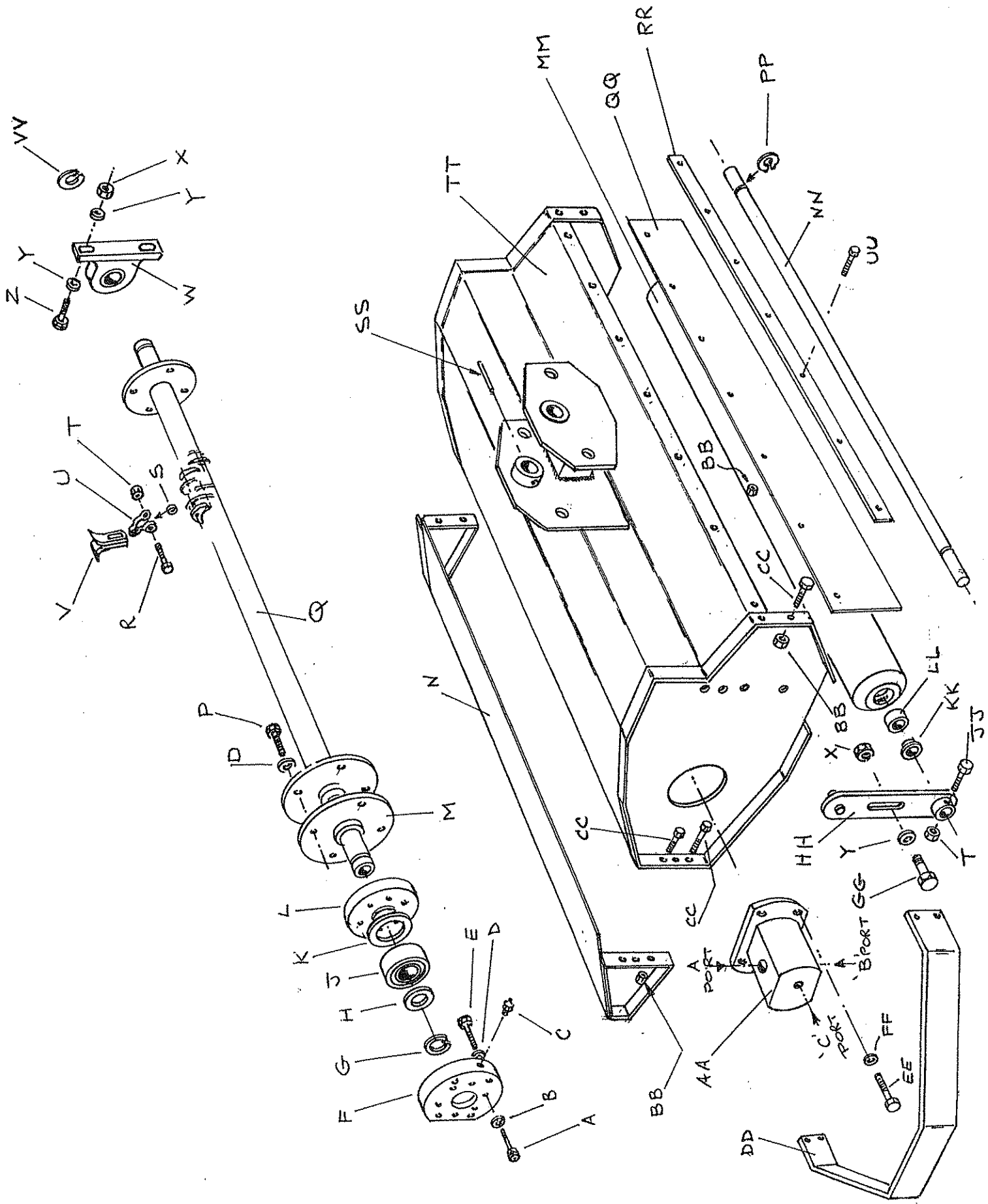

HEAD MOTOR 'PORTS'

(the following items are not illustrated)

<u>REF</u>	<u>PART NO.</u>	<u>DESCRIPTION</u>	<u>QTY</u>
<u>PORT A</u>			
*	6995	Elbow	1
*	0909	Seal 1/2" BSP	1
*	1826	Adaptor 1/2" BSP x 1/2" BSP	1

PORT B

*	6975	Elbow	1
*	0934	Seal 3/4" BSP	1
*	1834	Adaptor 3/4" x 1/2" BSP	1

PORT C (BLEED LINE)

*	1181	Seal 1/4" BSP	1
*	1823	Adaptor 1/4" x 1/4" BSP	1

Screws for Motor Elbow:-

Port 'A'

4415	M6 x 20 (8.8) Caphead	2
2731	M6 Spring Washer	2

Port 'B'

6994	M8 x 25 (8.8) Caphead	2
3001	M8 Spring Washer	2

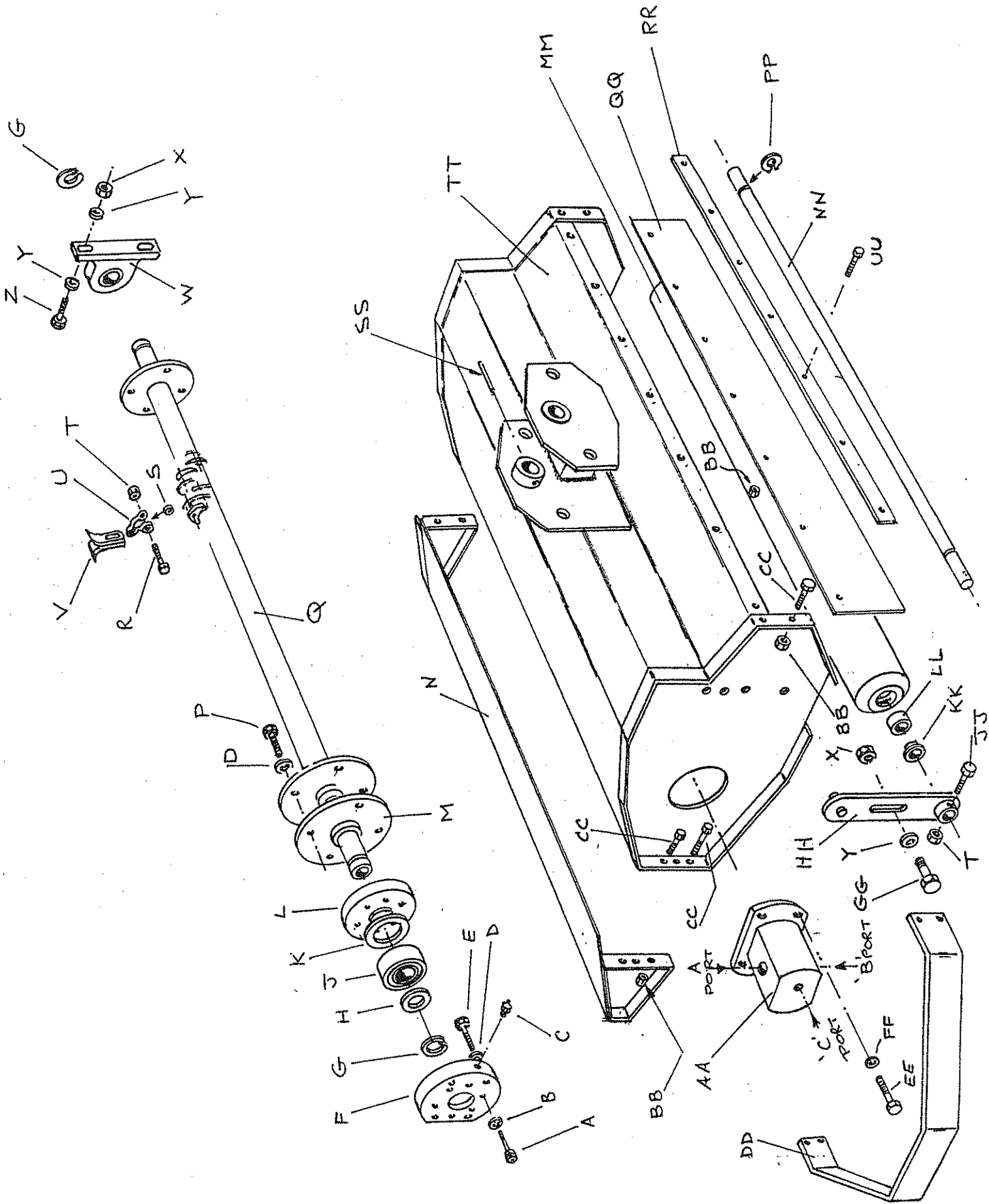

VALVE BLOCK AND FITTINGS

<u>REF</u>	<u>PART NO.</u>	<u>DESCRIPTION</u>	<u>QTY</u>
A	6965	Valve Block	1
B	0909	Seal 1/2" BSP	1
C	0670	Seal 3/8" BSP	11
D	0920	Plug 3/8" BSP	2
E	1826	Adaptor 1/2" x 1/2" BSP	1
F	0914	Adaptor 1/2" x 3/8" BSP	2
G	0665	Adaptor 3/8" x 3/8" BSP	2
H	1180	Adaptor 3/8" x 1/4" BSP	5
J	6996	Relief Valve (2000 PSI)	1

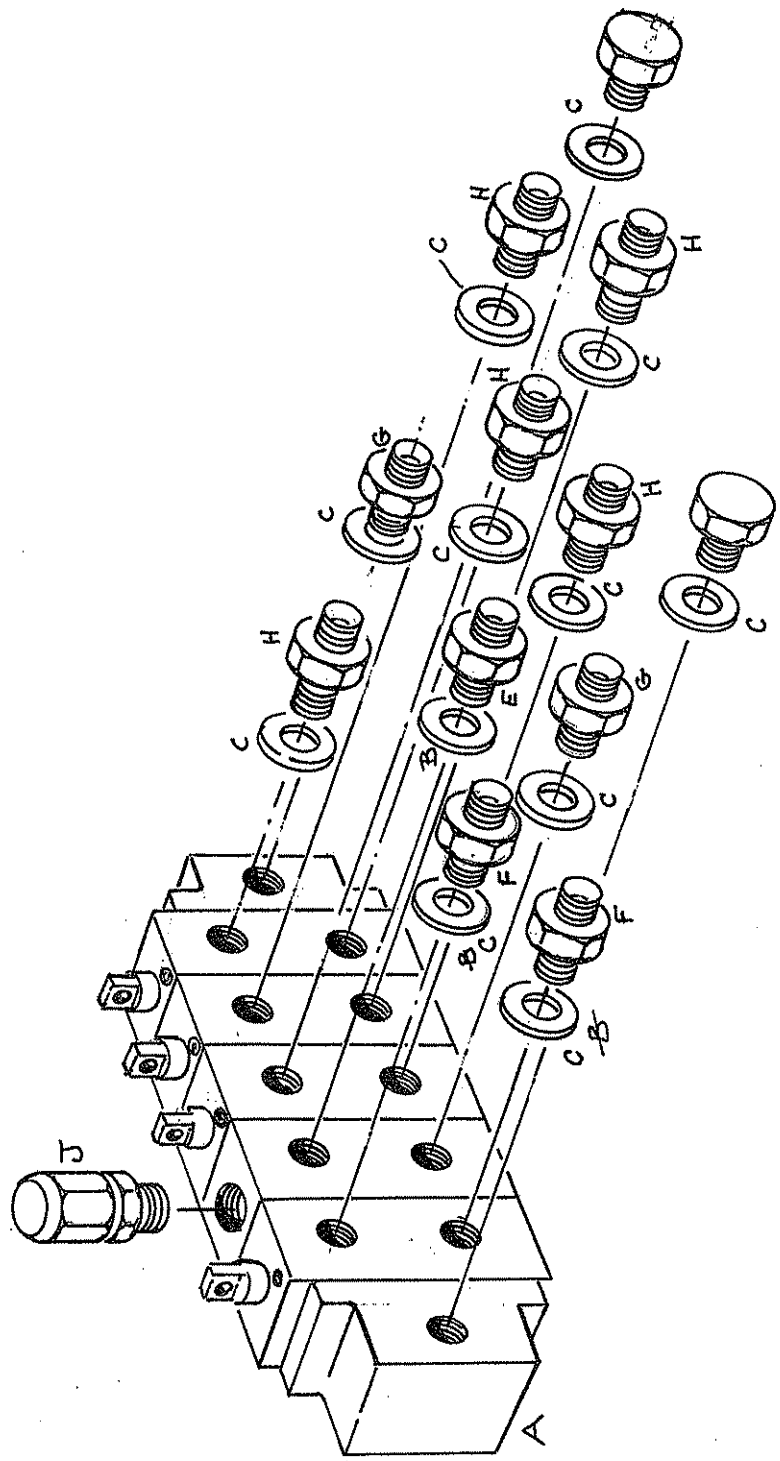

CABLE CONTROL AND MOUNTING BRACKET

<u>REF</u>	<u>PART NO.</u>	<u>DESCRIPTION</u>	<u>QTY</u>
A	6990	Bulk Head Mounting Plate	2
B	178.062	Mounting Plate for Control Handle	1
C	178.063	Rubber Mounting Block	1
D	2913	M6 x 16 (8.8) Setscrew	4
E	4776	M6 Stiffnut	4
F	2765	M8 x 70 (8.8) Bolt	1
G	3770	Washer	1
H	3111	M8 Flat Washer	1
J	2719	M8 Stiffnut	1
*	6945	Control Head	3
*	178.064	Control Head (Short) 'Motor Drive'	1
*	6989	Cables	4
*	6946	Cable Fitting kit complete	4
*	4695	M6 x 15 Caphead Setscrew (Trumpet Valve)	8
*	2731	M6 Spring Washer	8
*	178.065	Tie Bolts for Handles	2
*	4776	M6 Stiffnut	4

SAFETY SCREEN

*	178.067	Mesh Screen	1
*	3770	Penny Washer	8
*	3110	M8 x 30 Setscrew	4
*	3111	M8 Spring Washer	4
*	2766	M8 Nut	4

* Denotes parts not illustrated.

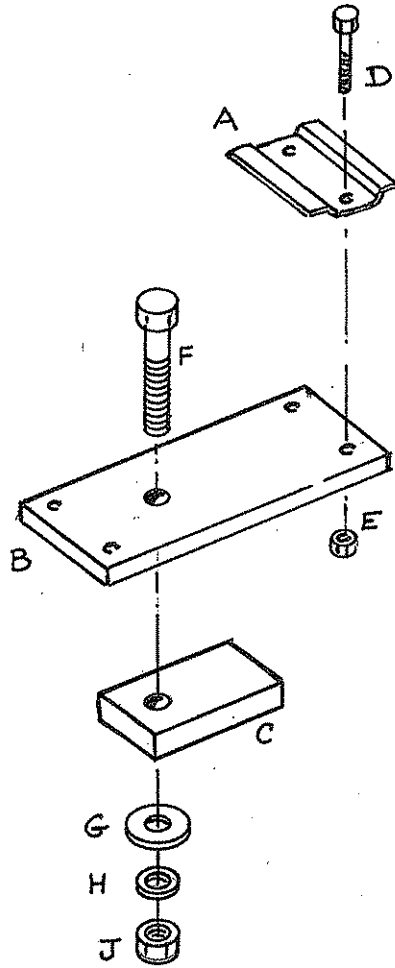

HYDRAULIC PIPING DIAGRAM

<u>REF</u>	<u>PART NO.</u>	<u>DESCRIPTION</u>	<u>QTY</u>	<u>FT25</u>	<u>FT30</u>
A-A	4/205	1/2" Hose 90 x 90 @ 110 x 365	1		
B-B	4/213	1/4" Hose 91 x 91 x 4280	1		
B-B	4/220	1/4" Hose 91 x 91 x 5020	1		
C-C	4/211	1/2" Hose 90 x 90 @ 90 x 4280	1		
C-C	4/218	1/2" Hose 90 x 90 @ 90 x 5020	1		
D-D	4/211	1/2" Hose 90 x 90 @ 90 x 4280	1		
D-D	4/218	1/2" Hose 90 x 90 @ 90 x 5020	1		
E-E	4/203	3/8" Hose 91 x 19 x 850	1		
F-F	4/224	1/4" Hose ST x 90 x 3850	1		
F-F	4/228	1/4" Hose ST x 91 x 3060	1		
G-G	4/225	1/4" Hose ST x 91 x 3800	1		
G-G	4/227	1/4" Hose ST x 90 x 3100	1		
H-H	4/223	1/4" Hose ST x 90 x 2360	1		
H-H	4/226	1/4" Hose ST x 90 x 2080	1		
I-I	4/208	1/4" Hose 90 x St. x 2030	1		
I-I	4/215	1/4" Hose 91 x St. x 2310	1		
J-J	4/206	1/4" Hose 90 x St. x 1520	1		
K-K	4/204	3/8" Hose 91 x 91 x 940	1		
L-L	4/202	3/4" Return Hose x 535	1		
M-M	4/201	1/2" Return Hose x 770	1		

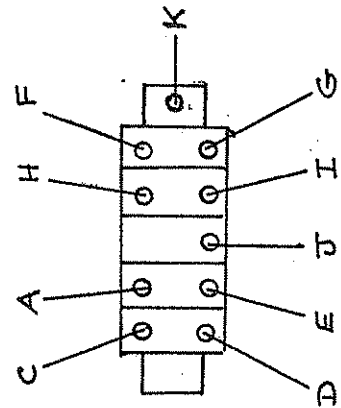
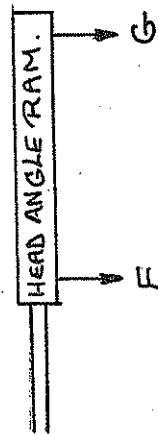
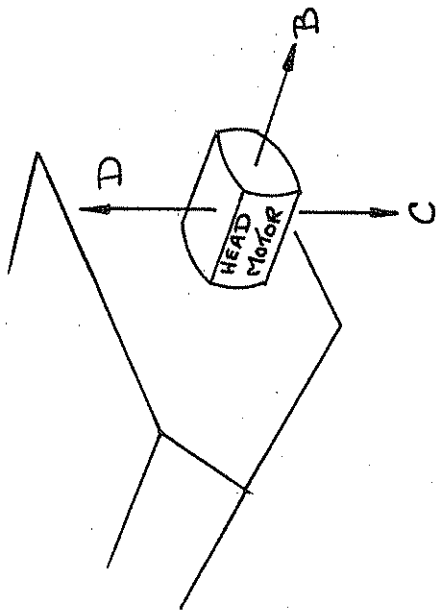
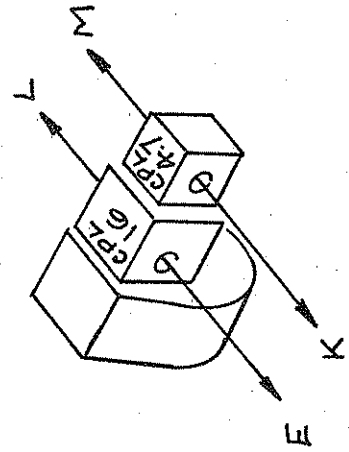
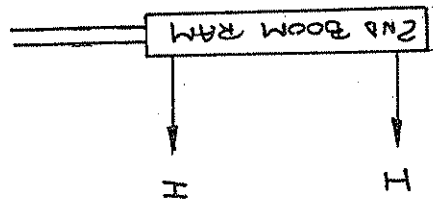
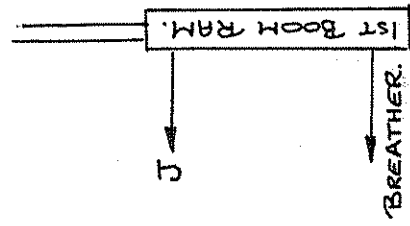
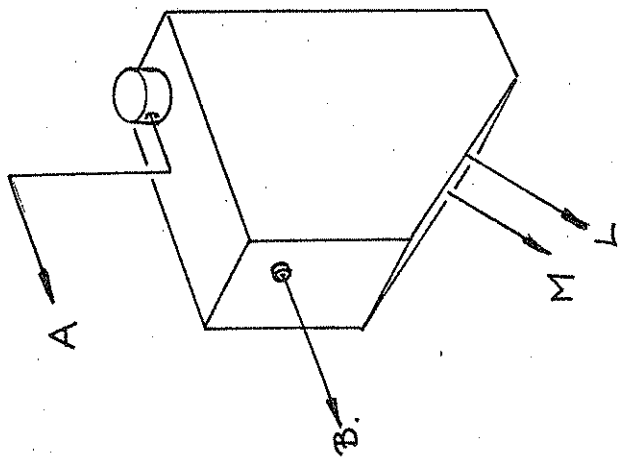

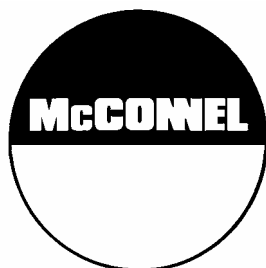

McConnel Limited, Temeside Works, Ludlow, Shropshire SY8 1JL. England.
Telephone: 01584 873131. Facsimile: 01584 876463. www.mcconnel.com