

## **Operator Manual**

# **Hy Reach Series**

*All linkage mounted models*



EC DECLARATION OF CONFORMITY  
*Conforming to EEC Directive 89/392/EEC*

We,

**McCONNEL LIMITED**, Temeside Works, Ludlow,  
Shropshire SY8 1JL.

*declare under our sole responsibility that*

the product (type) .. LINKAGE MOUNTED ARM FLAIL MOWER .....

Product Code .. P550, P650 .....

Serial No. & Date  Type

Manufactured by the above Company/\* .....

*(\*insert business name and full address if not stated above)*

◆-----◆  
complies with the required provisions of the Directive 89/392/EEC,  
and AMD 91/368/EEC, AMD 93/44/EEC, AMD 93/68/EEC and  
conforms with European Norm. BS EN 292.

**Part 1:1991 Safety of Machinery – Terminology, methodology.**  
**Part 2:1991 Safety of Machinery – Technical Specifications.**

and other national standards associated with its design and  
construction as listed in the Technical File.

Signed .. Adrian Longstaff ..  
on behalf of McCONNEL LIMITED Responsible Person

Status .. Director of Engineering .. Date 24<sup>th</sup> January 2001 ..

## **READ THE BOOK FIRST**

***It might save hours and pounds later !***

***When ordering spare parts always quote***

- ***The Machine Type***
- ***The Machine Serial Number***
- ***The Part Number***

***Factory re-built service exchange units of  
the major hydraulic components are  
available from your Dealer***

## **NOISE**

***The equivalent daily personal noise exposure from this machine, measured at the operators' ear, is within the range 78 – 85 DB.***

***These figures apply to a normal distribution of use where the noise fluctuates between zero and maximum. The figures assume that the machine is fitted to a tractor with a quiet cab with the windows closed in a generally open environment. We recommend that the windows are kept closed.***

***With the cab rear window open the equivalent daily personal noise exposure will increase to a figure within the range 82 – 88 DB.***

***At equivalent daily noise exposure levels of between 85 and 90 DB, ear protection is recommended, it should be used if any window is left open.***

## LIST OF CONTENTS

Section 1	-	Introduction	Page 1
Section 2	-	Safety Precautions	Page 6
Section 3	-	Fitting	Page 10
Section 4	-	Operation	Page 21
Section 5	-	Maintenance	Page 51



# GENERAL INFORMATION

Read this manual before fitting or operating the machine. Whenever any doubt exists contact your dealer or the McConnel Service Department for assistance.

Use only McConnel spare parts on McConnel equipment and machines.

## DEFINITIONS

The following definitions apply throughout this manual:

### WARNING

An operating procedure, technique etc., which can result in personal injury or loss of life if not observed carefully.

### CAUTION

An operating procedure, technique etc., which can result in the damage of either machine or equipment if not observed carefully.

### NOTE

An operating procedure, technique etc., which is considered essential to emphasise.

### Left and Right-Hand

This term is applicable to the machine when fitted to the tractor and viewed from the rear. This also applies to tractor references.

Record the serial number of your machine on this page and always quote this number when ordering spares. Whenever information concerning the machine is requested remember to also state the type of tractor to which it is fitted.	
MACHINE SERIAL NUMBER	INSTALLATION DATE
MODEL DETAILS	
DEALERS NAME	
DEALERS TELEPHONE NUMBER	

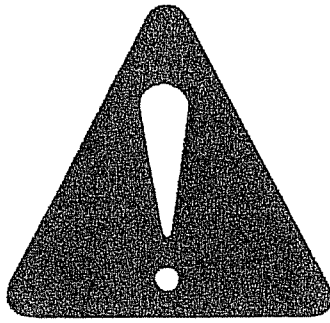

## **SAFETY INFORMATION**

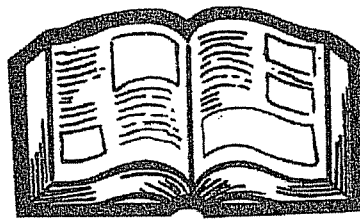

This machine has the potential to be extremely dangerous, in the wrong hands it can kill or maim. It is therefore imperative that the owner, and the operator of this machine, read the following section to ensure that they are both fully aware of the dangers that do, or may exist, and their responsibilities surrounding its use.

The operator of this machine is responsible not only for their own safety but equally for the safety of others who may come into the close proximity of the machine, as the owner you are responsible for both.

### **POTENTIAL SIGNIFICANT DANGERS ASSOCIATED WITH THE USE OF THIS MACHINE:**

- *Being hit by debris thrown by rotating components.*
- *Being hit by machine parts ejected through damage during use.*
- *Being caught on a rotating power take-off (PTO) shaft.*
- *Being caught in other moving parts i.e.: belts, pulleys and cutting heads.*
- *Electrocution from Overhead Power Lines (by contact with or 'flashover' from).*
- *Being hit by cutting heads or machine arms as they move.*
- *Becoming trapped between tractor and machine when hitching or unhitching.*
- *Tractor overbalancing when machine arm is extended.*
- *Injection of high-pressure oil from hydraulic hoses or couplings.*
- *Machine overbalancing when freestanding (out of use).*
- *Road traffic accidents due to collision or debris on the road.*

## **BEFORE USING THIS MACHINE YOU MUST:**

- *Ensure you read all sections of the operator handbook.*
- *Ensure the operator is, or has been, properly trained to use the machine.*
- *Ensure the operator has been issued with and reads the operator handbook.*
- *Ensure the operator understands and follows the instructions in operator handbook.*
- *Ensure the tractor front, rear and side(s) are fitted with metal mesh or polycarbonate guards of suitable size and strength to protect the operator against thrown debris or parts.*
- *Ensure tractor guards are fitted correctly, are undamaged and kept properly maintained.*
- *Ensure that all machine guards are in position, are undamaged, and are kept maintained in accordance with the manufacturer's recommendations.*
- *Ensure flails and their fixings are of a type recommended by the manufacturer, are securely attached and that none are missing or damaged.*
- *Ensure hydraulic pipes are carefully and correctly routed to avoid damage by chaffing, stretching or pinching and that they are held in place with the correct fittings.*
- *Always follow the manufacturer's instructions for attachment and removal of the machine from the tractor.*
- *Check that the machine fittings and couplings are in good condition.*
- *Ensure the tractor meets the minimum weight recommendations of the machine manufacturer and that ballast is used as necessary.*
- *Always inspect the work area thoroughly before starting to note obstacles and remove wire, bottles, cans and other debris.*
- *Use clear suitably sized warning signs to alert others to the nature of the machine working within that area. Signs should be placed at both ends of the work site. (It is recommended that signs used are of a size and type specified by the Department of Transport and positioned in accordance with their and the Local Highways Authority guidelines).*
- *Ensure the operator is protected from noise. Ear defenders should be worn and tractor cab doors and windows must be kept closed. Machine controls should be routed through proprietary openings in the cab to enable all windows to be shut fully.*
- *Always work at a safe speed taking account of the conditions i.e.: terrain, highway proximity and obstacles around and above the machine.*
- *Extra special attention should be applied to Overhead Power Lines. Some of our machines are capable of reach in excess of 8 metres (26 feet) this means they have the potential to well exceed, by possibly 3 metres (9' 9"), the lowest legal minimum height of 5.2 metres from the ground for 11,000 and 33,000 volt power lines. It cannot be stressed enough the dangers that surround this capability, it is therefore vital that the operator is fully aware of the maximum height and reach of the machine, and that they are fully conversant with all aspects regarding the safe minimum distances that apply when working with machines in close proximity to Power Lines. (Further information on this subject can be obtained from the Health & Safety Executive or your Local Power Company).*
- *Always disengage the machine, kill the tractor engine, remove and pocket the key before dismantling for any reason.*



- *Always clear up all debris left at the work area, it may cause hazard to others.*
- *Always ensure when you remove your machine from the tractor that it is left in a safe and stable position using the stands and props provided and secured if necessary.*

## **WHEN NOT TO USE THIS MACHINE:**

- *Never attempt to use this machine if you have not been trained to do so.*
- *Never uses a machine until you have read and understood the operator handbook, are familiar with, and practiced the controls.*
- *Never use a machine that is poorly maintained.*
- *Never use a machine if guards are missing or damaged.*
- *Never use a machine on which the hydraulic system shows signs of wear or damage.*
- *Never fit, or use, a machine on a tractor that does not meet the manufacturer's minimum specification level.*
- *Never use a machine fitted to a tractor that does not have suitable front, rear and side(s) cab guarding made of metal mesh or polycarbonate.*
- *Never use the machine if the tractor cab guarding is damaged, deteriorating or badly fitted.*
- *Never turn a machine cutting head to an angle that causes debris to be ejected towards the cab.*
- *Never start or continue to work a machine if people are nearby or approaching - Stop and wait until they are at a safe distance before continuing.*
- *Never attempt to use a machine on materials in excess of its capability.*
- *Never use a machine to perform a task it has not been designed to do.*
- *Never operate the tractor or machine controls from any position other than from the driving seat, especially whilst hitching or unhitching the machine.*
- *Never carry out maintenance of a machine or a tractor whilst the engine is running – the engine should be switched off, the key removed and pocketed.*
- *Never leave a machine unattended in a raised position – it should be lowered to the ground in a safe position on a level firm site.*
- *Never leave a tractor with the key in or the engine running.*
- *Never carry out maintenance on any part or component of a machine that is raised unless that part or component has been properly substantially braced or supported.*
- *Never attempt to detect a hydraulic leak with your hand – use a piece of cardboard.*
- *Never allow children near to, or play on, a tractor or machine under any circumstances.*

## **ADDITIONAL SAFETY ADVICE**

### **TRAINING**

Operators need to be competent and fully capable of operating this machine in a safe and efficient way prior to attempting to use it in any public place. We advise therefore that the prospective operator make use of relevant training courses available such as those run by the Agricultural Training Board, Agricultural Colleges, Dealers and McConnel.

### **WORKING IN PUBLIC PLACES**

When working in public places such as roadsides, consideration should be paid to others in the vicinity. Stop the machine immediately when pedestrians, cyclists and horse riders etc. pass. Restart only when they are at a distance that causes no risk to their safety.

### **WARNING SIGNS**

It is advisable that any working area be covered by suitable warning signs and statutory in public places. Signs should be highly visible and well placed in order to give clear advanced warning of the hazard. Contact the Department of Transport or your Local Highways Authority to obtain detailed information on this subject. The latter should be contacted prior to working on the public highway advising them of the time and location of the intended work asking what is required by way of signs and procedure. – *'Non-authorized placement of road signs may create offences under the Highways Act'*.

### **SUGGESTED WARNING SIGNS REQUIRED**

*"Road works ahead" warning sign with a supplementary "Hedge cutting" plate. "For 1 mile" or appropriate shorter distance may be added to the plate.*

*"Road narrows" warning sign with supplementary "Single file traffic" plate.*

*White on blue "Keep right" arrow sign on rear of machine.*

### **USE OF WARNING SIGNS**

- *On two way roads one set of signs is needed facing traffic in each direction.*
- *Work should be within 1 mile of the signs.*
- *Work only when visibility is good and at times of low risk e.g.: NOT during 'rush-hour'.*
- *Vehicles should have an amber flashing beacon.*
- *Ideally, vehicles should be conspicuously coloured.*
- *Debris should be removed from the road and path as soon as practicable, and at regular intervals, wearing high visibility clothing and before removing the hazard warning signs.*
- *Collect all road signs promptly when the job is completed.*

---

Although the information given here covers a wide range of safety subjects it is impossible to predict every eventuality that can occur under differing circumstances whilst operating this machine. No advice given here can replace 'good common sense' and 'total awareness' at all times but will go a long way towards the safe use of your McConnel machine.

---

# **FITTING**

## **TRACTOR REQUIREMENTS**

### **MINIMUM TRACTOR WEIGHTS INCLUDING BALLAST WEIGHT IF NECESSARY**

Hy-Reach 550 - 4000 Kg

Hy-Reach 650 - 4500 Kg

### **MIN HP REQUIREMENTS**

Hy-Reach 550 - 70 Hp

Hy-Reach 650 - 75 Hp

### **LINKAGE**

Category II

### **PTO SHAFT**

Tractor must be equipped with a live drive independent P.T.O. to enable forward motion to be stopped while the flail head continues to operate.

## VEHICLE/ TRACTOR PREPARATION

We recommend vehicles are fitted with cabs using safety glass windows and protective guarding when used with our machines.

**Fit Operator Guard** (part no. 73 13 324) using the hooks provided. Shape mesh to cover all vulnerable areas.

**Remember** the driver must be looking through mesh and/or polycarbonate glazing when viewing the flail head in any working position - unless the vehicle/ cab manufacturer can demonstrate that the penetration resistance is equivalent to, or higher than, that provided by mesh/polycarbonate glazing. If the tractor has a roll bar only, a frame must be made to carry both mesh and polycarbonate glazing. The operator should also use personal protective equipment to reduce the risk of serious injury such as; eye protection (mesh visor to EN1731 or safety glasses to EN166), hearing protection to EN352, safety helmet to EN297, gloves, filter mask and high visibility clothing.

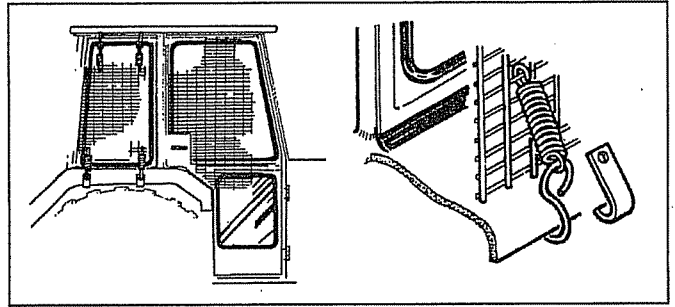

**Vehicle Ballast:** It is imperative when attaching 'third-party' equipment to a vehicle that the maximum possible stability of the machine and vehicle combination is achieved – this can be accomplished by the utilisation of 'ballast' in order to counter-balance the additional equipment added.

**Front weights** may be required for rear mounted machines to place 15% of total outfit weight on the front axle for stable transport on the road and to reduce 'crabbing' due to the drag of the cutting unit when working on the ground.

**Rear weights** may be required to maintain a reasonable amount of rear axle load on the opposite wheel from the arms when in work; for normal off-ground work i.e. hedge cutting this should be 20% of rear axle weight or more for adequate control, and for ground work i.e. verge mowing with experienced operators, this can be reduced to 10%.

All factors must be addressed in order to match the type and nature of the equipment added to the circumstances under which it will be used – in the instance of Power Arm Hedgecutters it must be remembered that the machines centre of gravity during work will be constantly moving and will differ from that during transport mode, therefore balance becomes critical.

### **Factors that effect stability:**

- *Centre of gravity of the tractor/machine combination.*
- *Geometric conditions, e.g. position of the cutting head and ballast.*
- *Weight, track width and wheelbase of the tractor.*
- *Acceleration, braking, turning and the relative position of the cutting head during these operations.*
- *Ground conditions, e.g. slope, grip, load capability of the soil/surface.*
- *Rigidity of implement mounting.*

### **Suggestions to increase stability:**

- *Increasing rear wheel track; a vehicle with a wider wheel track is more stable.*
- *Ballasting the wheel; it is preferable to use external weights but liquid can be added to around 75% of the tyre volume – water with anti-freeze or the heavier Calcium Chloride alternative can be used.*
- *Addition of weights – care should be taken in selecting the location of the weights to ensure they are added to a position that offers the greatest advantage.*
- *Front axle locking, check with tractor manufacturer.*

The advice above is offered as a guide for stability only and is not a guide to vehicle strength. It is therefore recommended that you consult your vehicle manufacturer or local dealer to obtain specific advice on this subject, additionally advice should be sought from a tyre specialist with regard to tyre pressures and ratings suitable for the type and nature of the machine you intend to fit.

## INITIAL ATTACHMENT TO TRACTOR

The machine will be delivered in a partially dismantled condition secured with transport strap and banding.

Choose a firm level site.

Remove the transport strap, banding straps and remove loose items

Fill tank with oil from the chart or equivalent

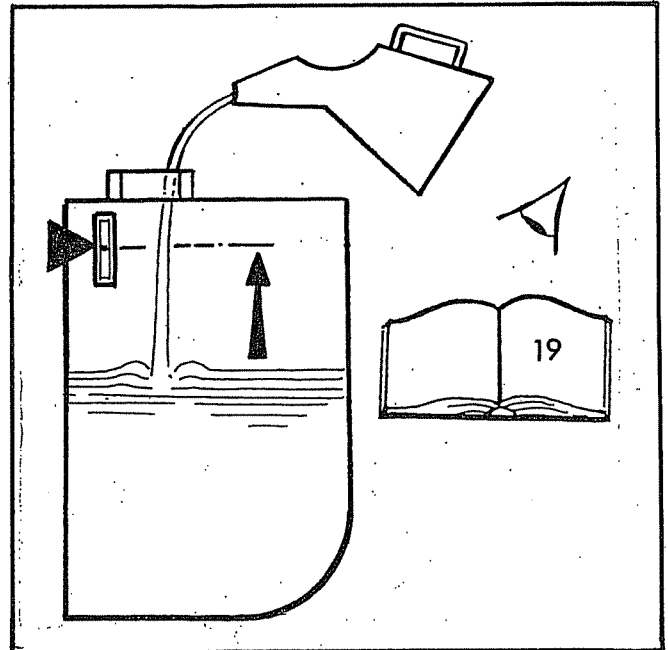

Raise the machine using overhead lifting equipment with a minimum capacity of 1500 kg SWL **LEAVE IN POSITION AT THIS STAGE**

Lower the legs and pin in position selecting the holes that position the machines gearbox stub shaft approx. 75mm below the tractor's p.t.o. shaft

Note:- Leg pin position used

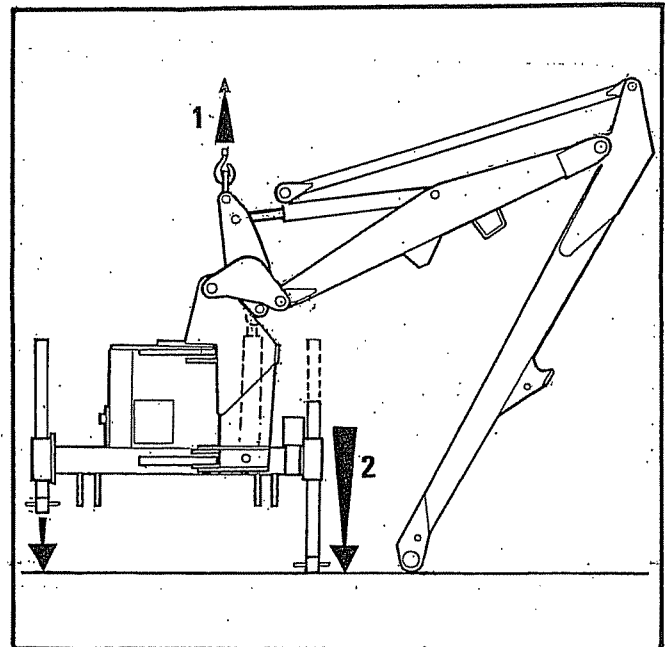

Unbolt stabiliser from machine and remove the stabiliser nose quadrant pin

Reverse tractor squarely up to the machine

Connect the tractors draft links selecting the rearmost hole in the machines lower link brackets that allow the machine to be mounted without contacting the tractor. Ensure the same hole is used both sides

If necessary fit the spacers supplied as required to minimise sideways movement of the tractors draft links within the hitch brackets

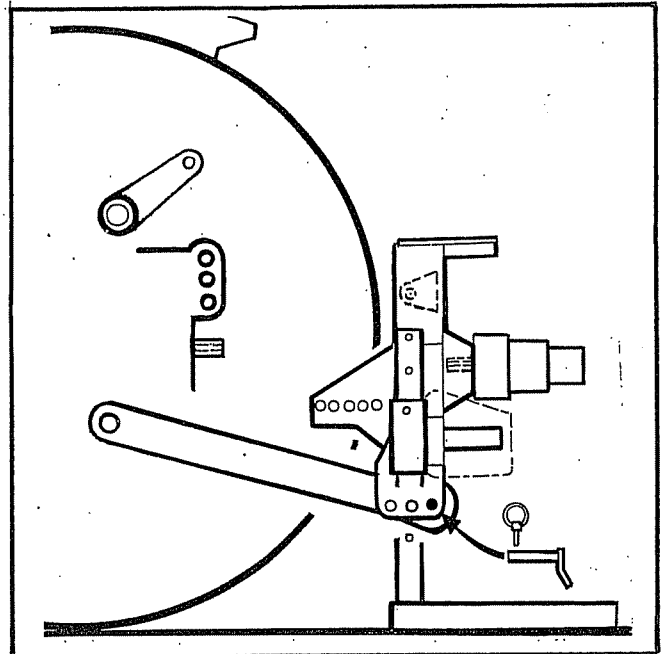

The lifting equipment may now be removed

Fit the stabiliser nose into the tractors top link position. Use the highest position available avoiding any load sensing properties. The bolt on nose of the stabiliser is reversible to accommodate a variety of tractor linkage designs

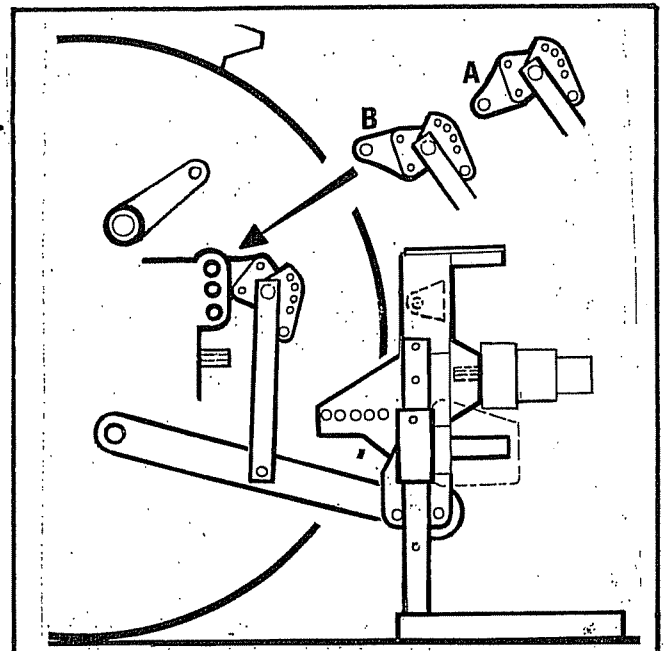

Stretch out the stabiliser and bolt to the machine using the holes farthest from the tractor that the stabiliser will reach. Do not fully tighten bolts at this stage and do not replace the stabiliser nose quadrant pin.

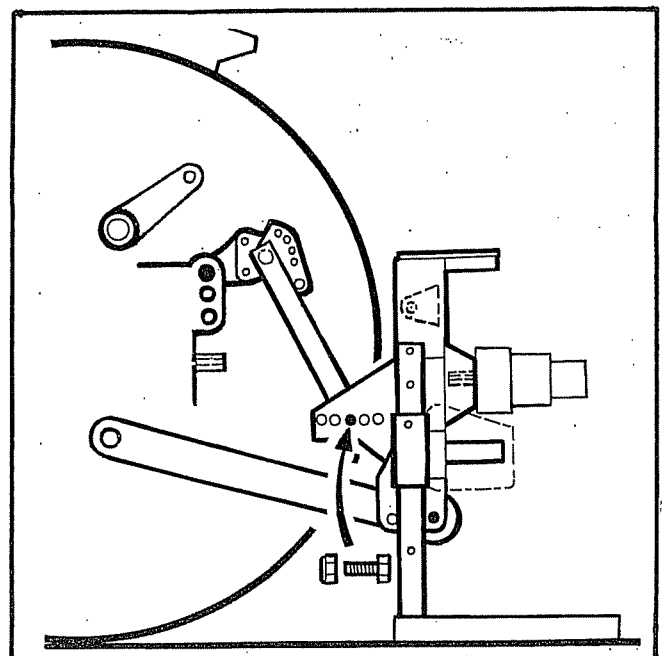

Fit the machines top link

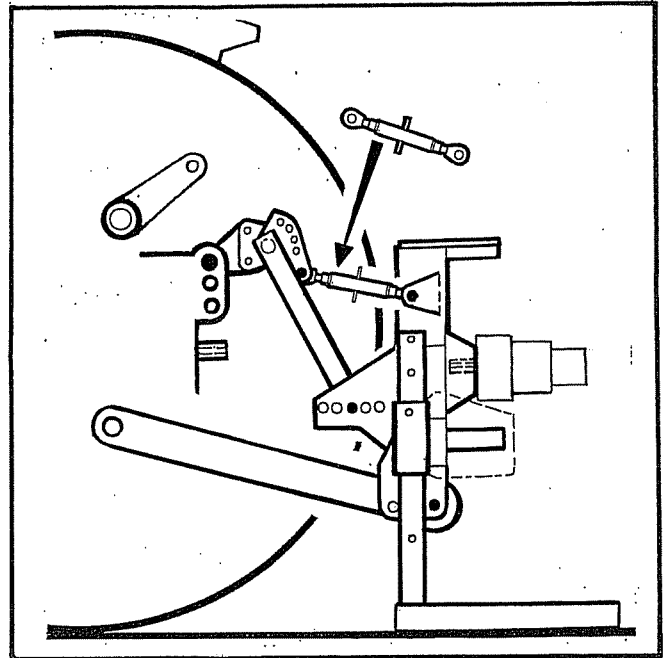

Raise machine on tractors linkage until the tractors p.t.o. and the machines gearbox stub shaft are approx. in line

**WARNING**

The quadrant lever or machine controls must be operated from the tractor seat. During this operation ensure no one is standing on or amongst the linkage arm or bars.

**Note:**  
As lift occurs be aware the machinery may tilt slightly.

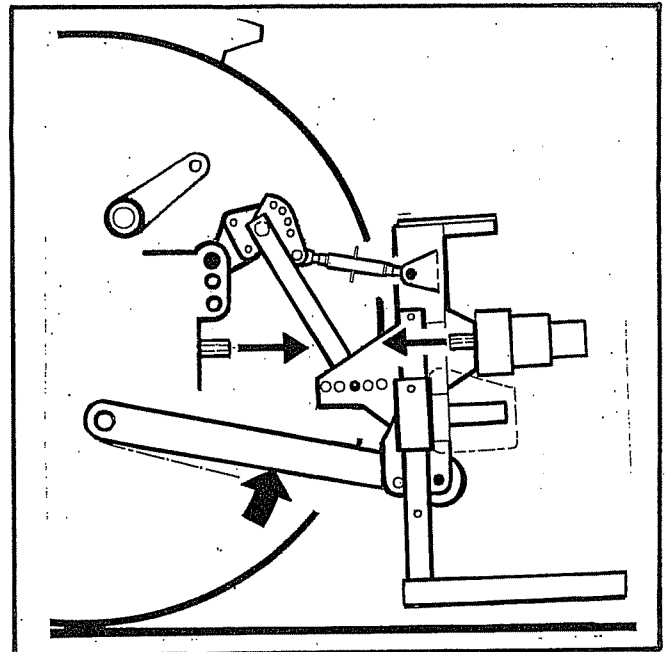

Adjust the top link to bring the machines frame vertical

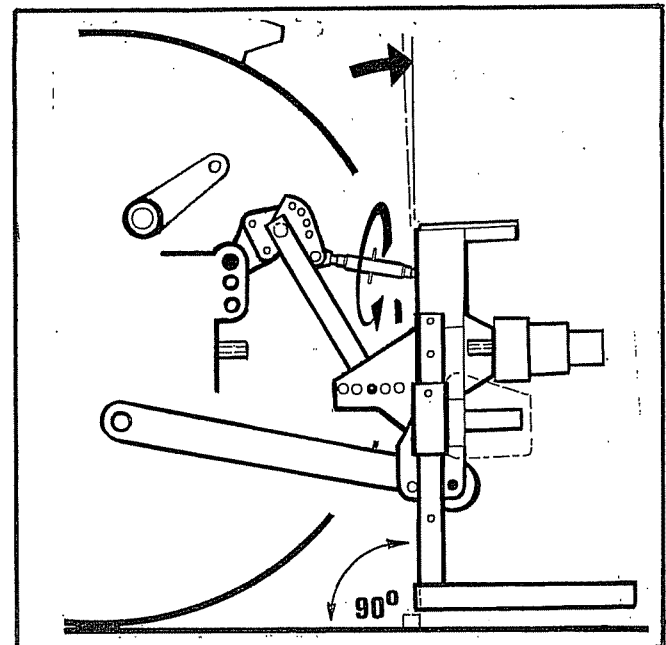

Refit the top link nose quadrant pin, fine adjust position using the tractors draft lift if required

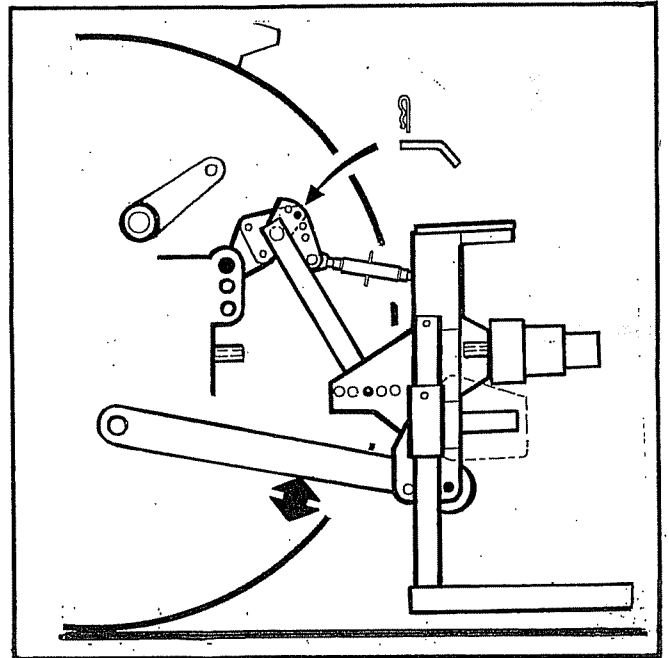

Fully tighten the stabiliser lower bolts

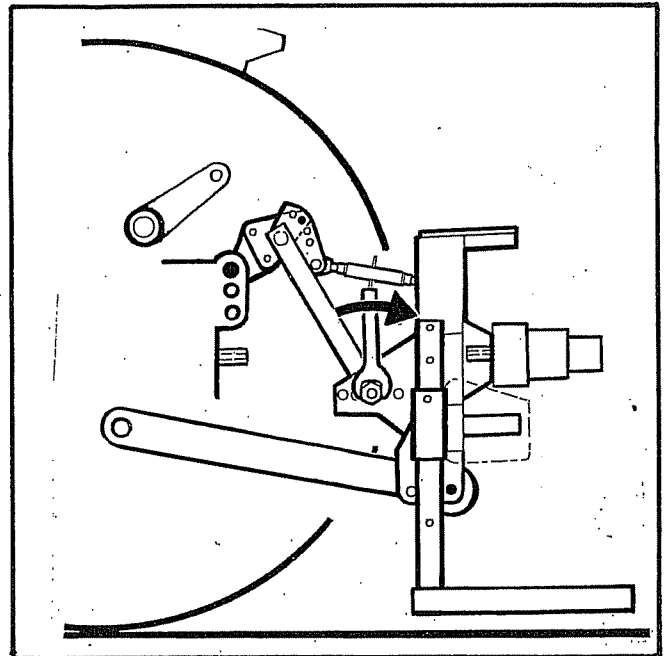

Measure p.t.o. and cut to dimension shown. See maintenance section for details. Note:- for subsequent use on different tractors measure again. There must be a minimum of 150mm of shaft overlap

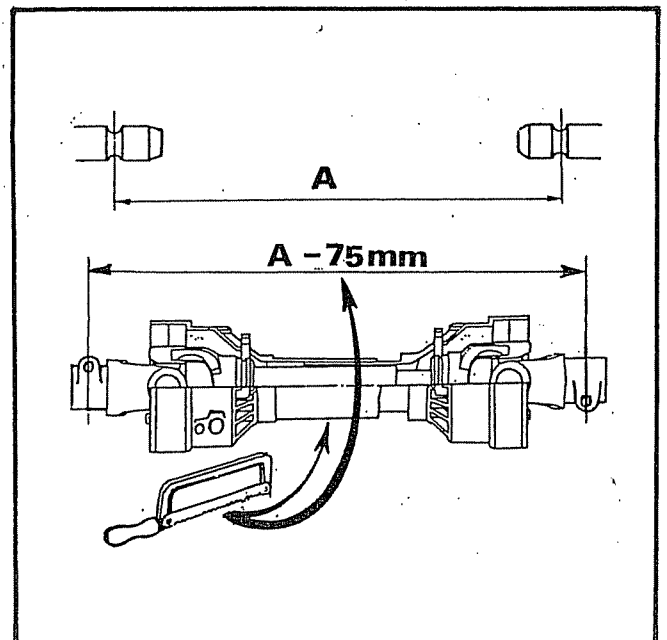



Fit p.t.o. shaft in position.  
Attach torque chains to a convenient  
location to prevent shaft guards  
rotating

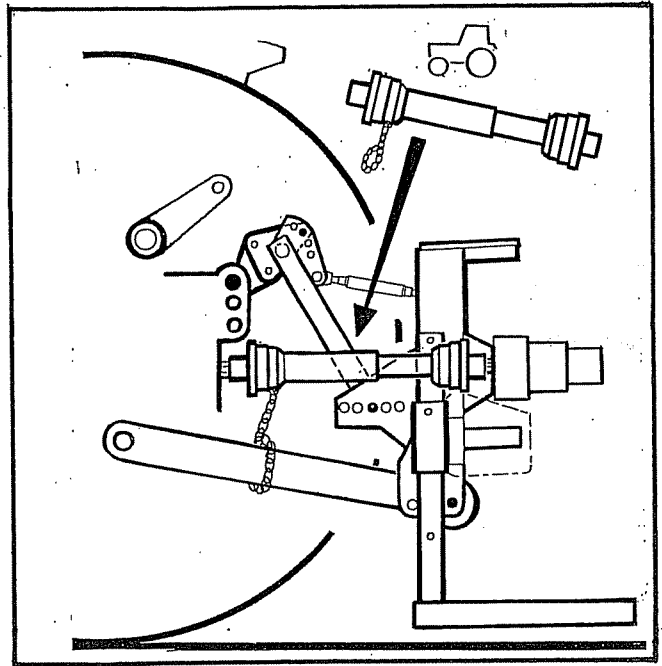

Fit machine controls into the cab  
see page 20

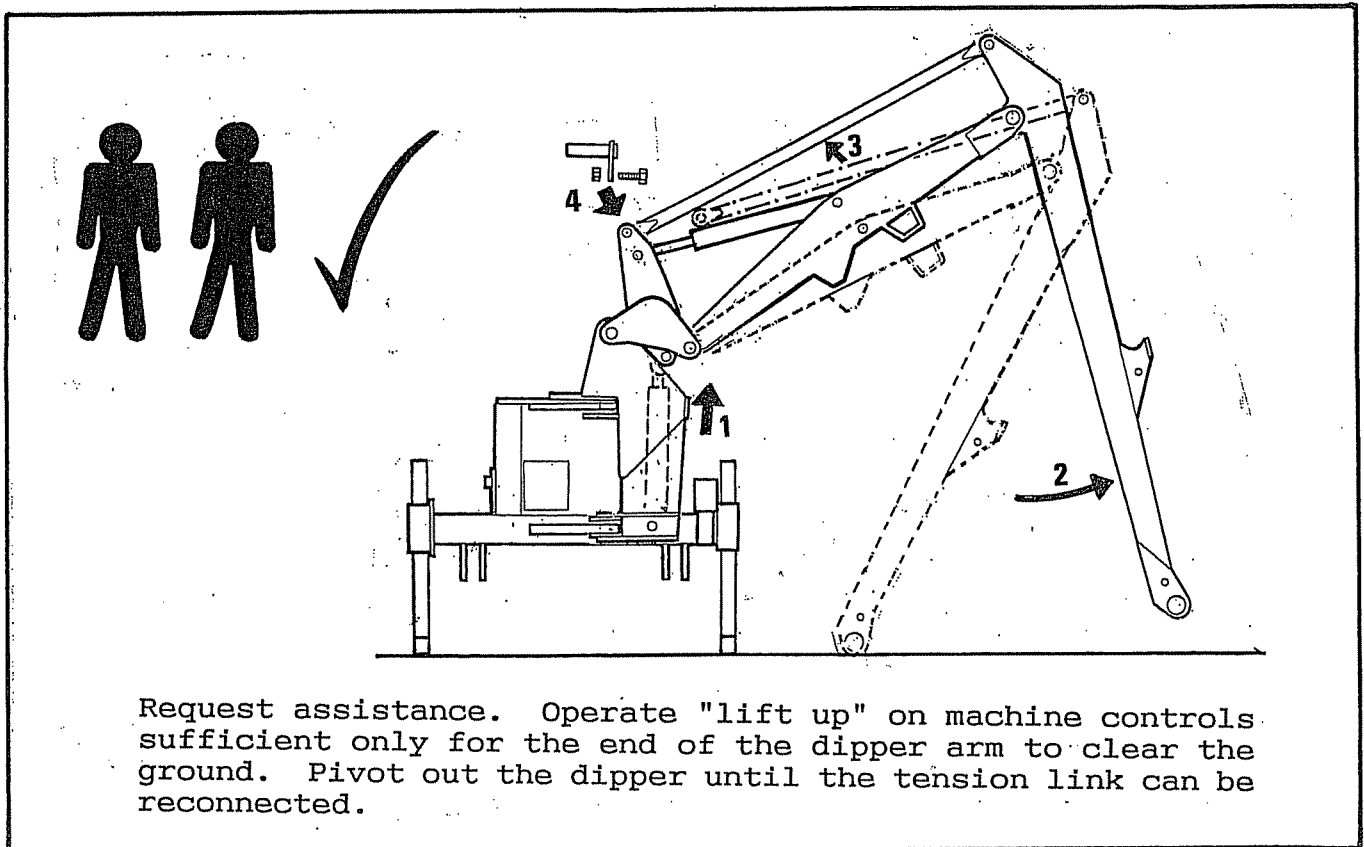
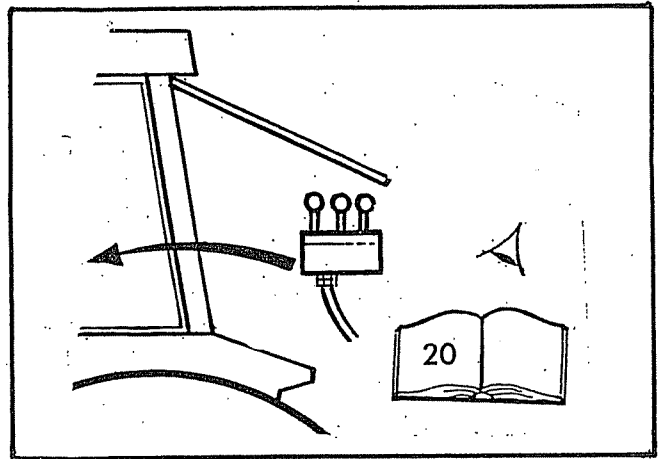

Request assistance. Operate "lift up" on machine controls  
sufficient only for the end of the dipper arm to clear the  
ground. Pivot out the dipper until the tension link can be  
reconnected.

On gear hydraulic machines only.

Operate machine controls and manoeuvre until the flail head can be attached. The bottom of the hose junction bracket must be parallel with the ground. Refer to "pre operational checks" for correct bolt torque settings

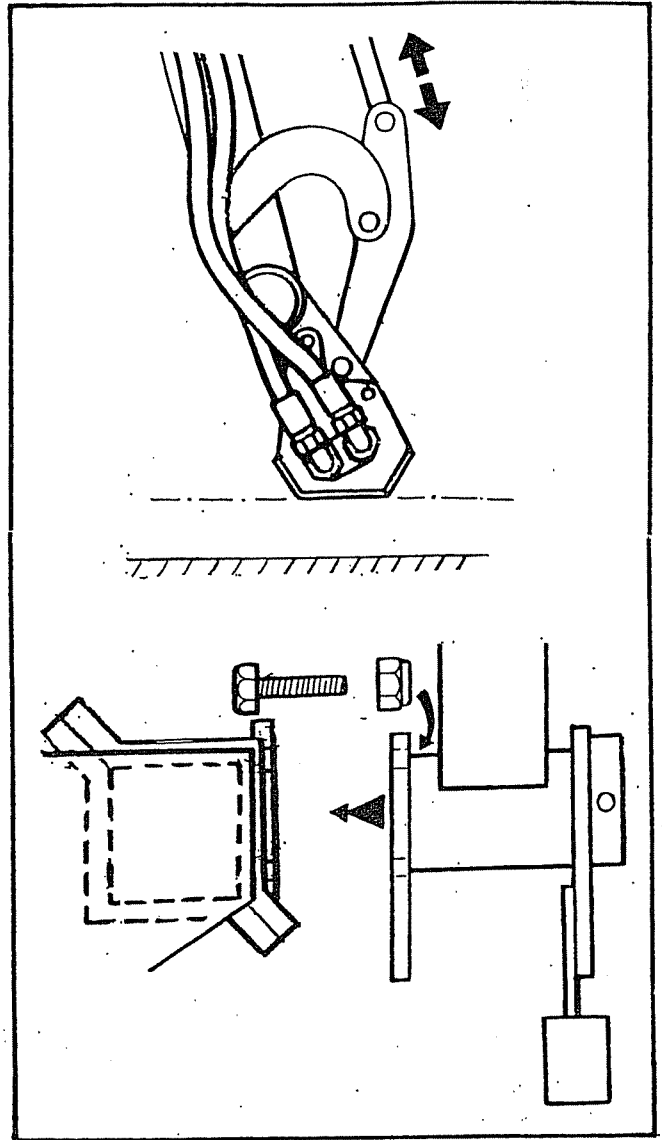

On gear hydraulic machines only.

Connect up flail hoses as indicated

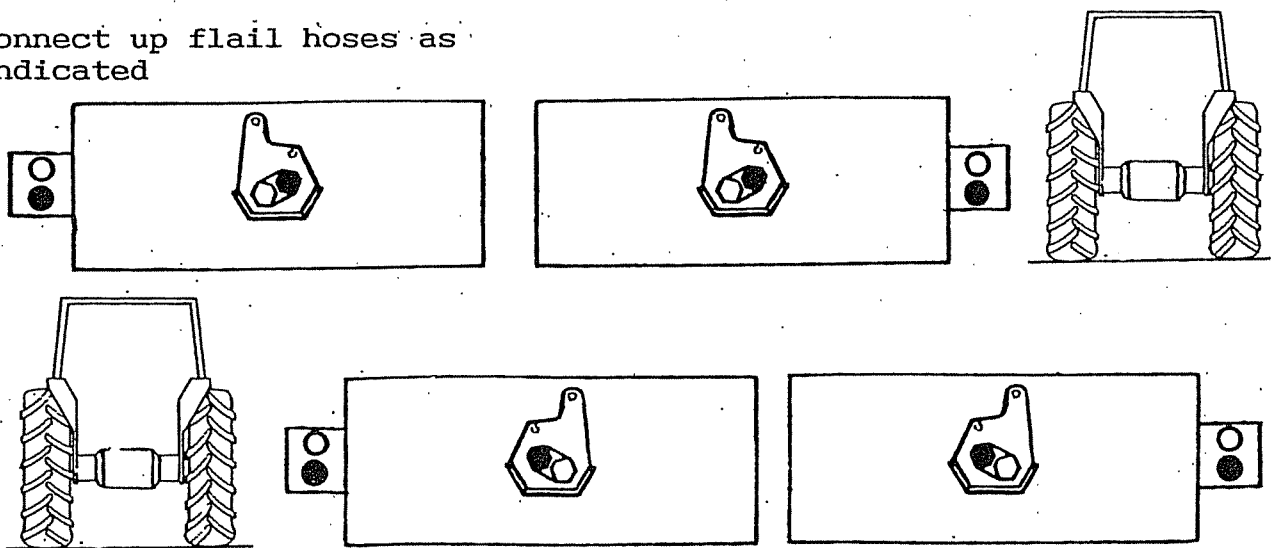

With the arms at half reach and with the flail head clear of the ground carry out final adjustment of the lift arm levelling box to bring the main frame horizontal

Raise the stand legs into the work position and secure

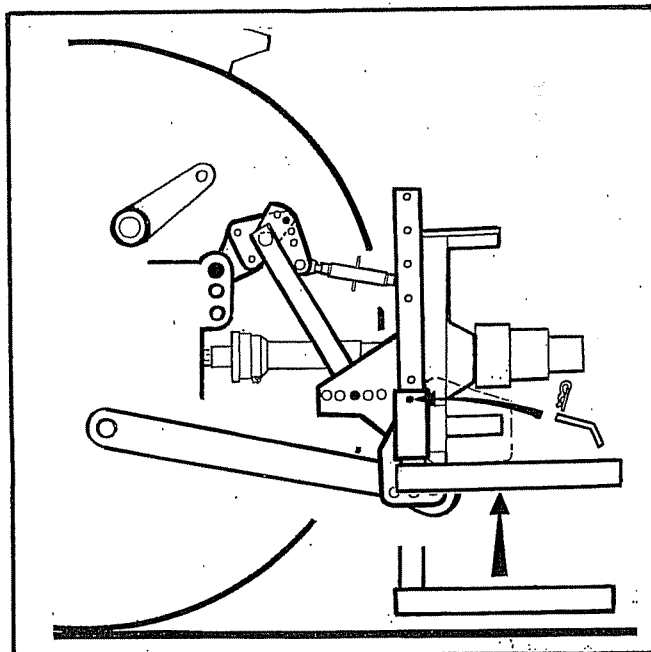

Tighten check chains and/or stabiliser bars

Carefully operate the machine through its full range of movements whilst checking that hoses are not strained, pinched, chafed or kinked and that all movements are functioning correctly

Fold the machine into the transport position (see page 39). The machine is now ready to proceed to the work site.

## OIL REQUIREMENTS

### Tank

Fill the reservoir to approximately 2" below the top of the tank.  
The capacity is approximately 180 litres

Do not overfill.

Supplier	Cold or temperate climate	Hot climate
Castrol	Agricastrol hydraulic oil Hy-spin AWS 46	Hy-spin AWS68
Shell	Tellus 46	Tellus 68
Mobil	D.T.E. 25	D.T.E.26
Esso	Nuto 'H' or 'A' 46	Nuto 'H'or'A' 68
Texaco	Rando HD 46	Rando D 68
Gulf	Hydrasil 46	Hydrasil 68
B.P.	Energol HLP 46	Energol HLP 68
Dalton	Silkolene Dove 46 or Derwent 46	Silkolene Dove 68 or Derwent 68
Elf	Hydrelf 46	Hydrelf 68

## FITTING CONTROL UNIT IN CAB

A mounting fitting is supplied to which the control unit is bolted. The fitting is bolted to the tractor ensuring that no structural member of the cab or roll bar is drilled and it can be bent or twisted to achieve a comfortable working position.

The supply cable should be connected directly to the tractors battery or to any 30 amp electrical output provided by the tractor manufacturer. Avoid using cigarette lighter type connections as these may prove to be sporadic and unreliable for control applications.

The control is 12 volt D.C. operated; the red lead is Positive and the black is Negative.

## RUNNING UP PROCEDURE

Ensure that the rotor control is in "STOP" position, start tractor, engage P.T.O. allow the oil to circulate through the return line filter for about 5 minutes without operation of the armhead control lever.

Operate the armhead levers through their complete range ensuring that all movements are functioning correctly.

Place the flail head at a safe attitude and move the rotor control to "START" position. After initial fluctuation the rotor should settle to a steady speed. Increase P.T.O. speed to approximately 650 rpm and run for a further five minutes before disengaging and stopping tractor.

### Caution

Do not allow the pump to continue working if the cutter does not operate. Overheating and serious damage to the pump can be caused in a very short time.

Check the hose runs and observe that they are free from any pinching, chafing, straining or kinks. Re-check the oil level in the tank and top up as necessary.

# PRE OPERATIONAL CHECKS

Check:- Oil level in hydraulic tank

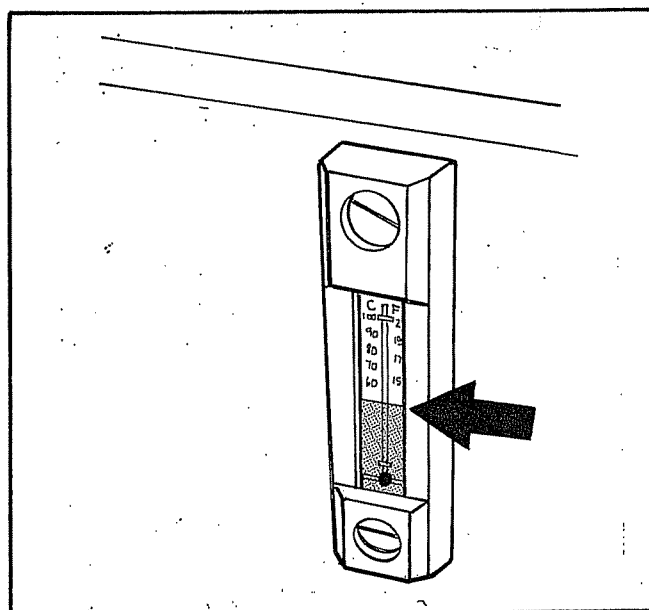

Check:- Oil level in gearbox

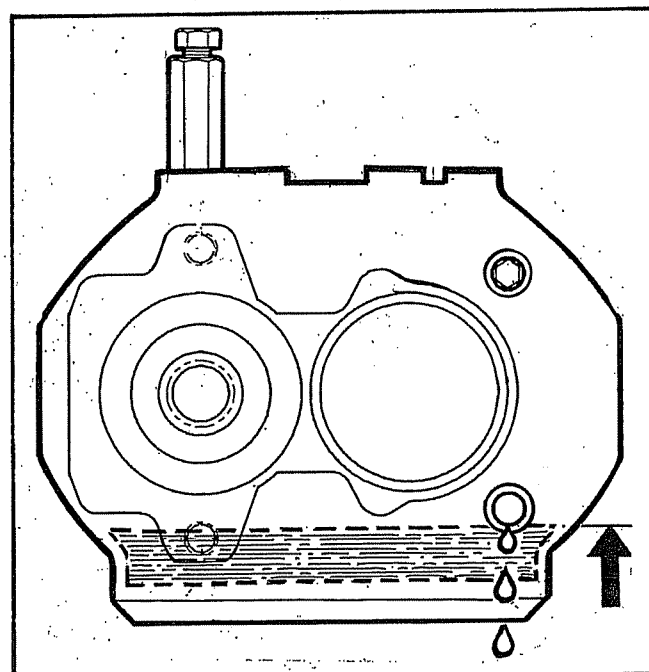

Check:- The compressed length of the top link rubber damper

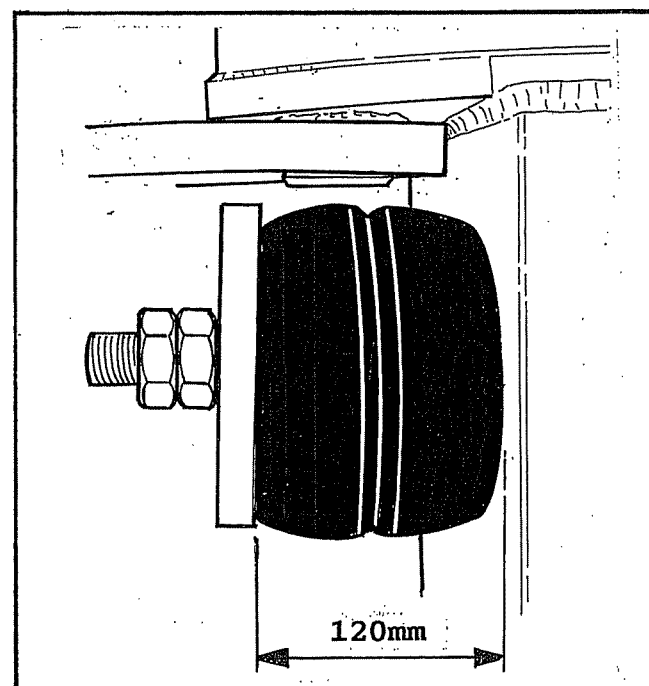

Check:- All bolts are tight and that the torque figures are correct for the specific locations shown below.

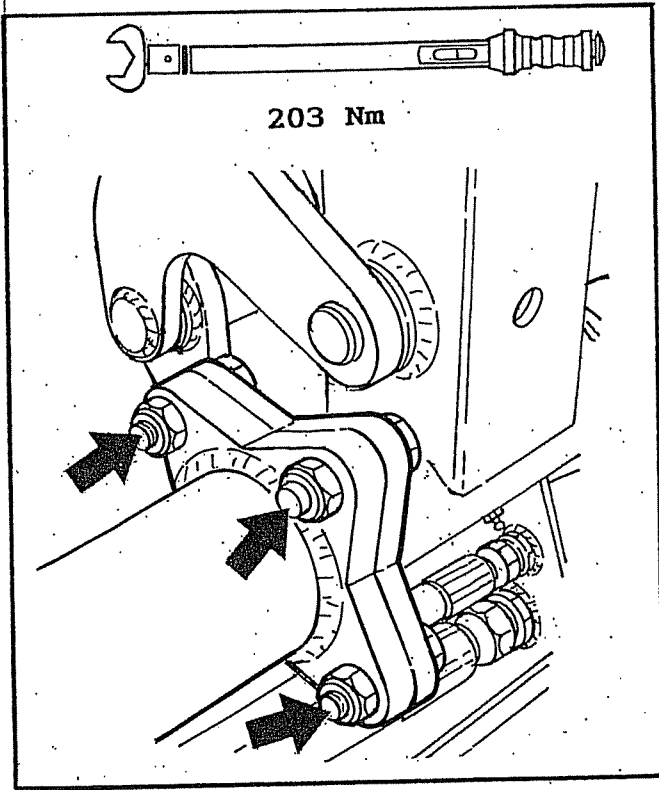



# OPERATION

## OPERATOR GUARD

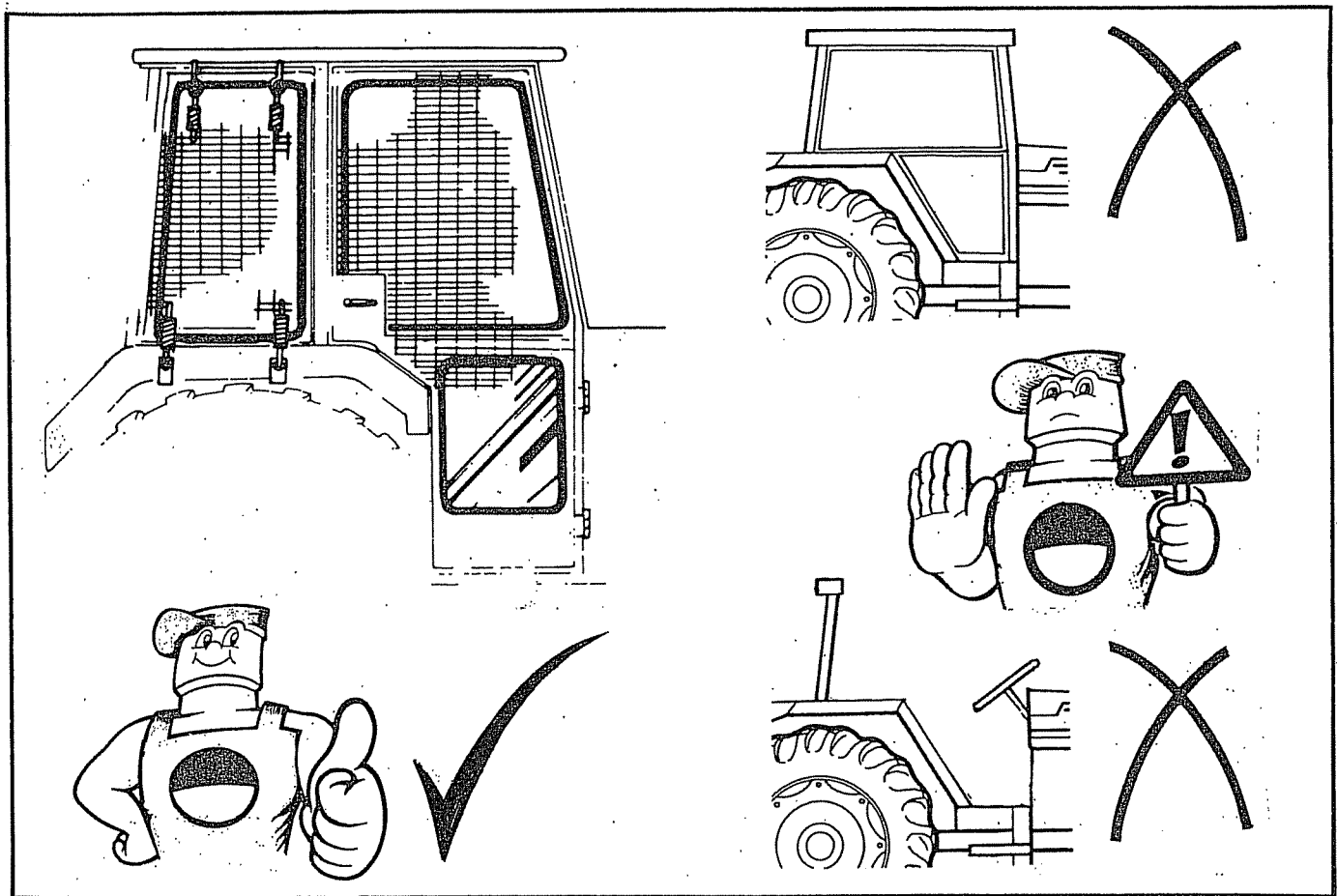

## MACHINE GUARDS

Before each period of work check that all the relevant machine guards are in position and are in good condition.

Small splits and abrasions to the lower edges of the rubber flaps are permissible but should one of these cuts or splits attain fifty per cent of flap height it will become ineffective for debris containment and should be replaced immediately.

## OPERATOR SAFETY

During operation all the tractor windows should be kept closed except the rear window which may be open - only sufficient to allow the entry of control cables into the cab.

Should the tractor not be equipped with a "quiet" cab ear defenders must be worn or permanent damage to hearing may occur.

Although in normal circumstances rotating parts should never be approached it is a wise precaution to avoid wearing loose or flapping clothing especially scarves and neckties.

The operator should continually guard against the complacency that can arise from familiarity. Never attempt to take short cuts, always follow the correct procedures diligently and abide by the restrictions imposed by safety considerations. **REMEMBER: THE ONLY WAY IS THE SAFE WAY.**

## PREPARATION

Read the book first.

Practise in an open space without the rotor running until familiar with controls.

**Caution:** Take care when working with the head close in as it can hit the tractor.

## RUNNING IN NEW MACHINE

For the first days work it is recommended that tractor forward speed is restricted to 3Km/hr max. This will allow machine components to bed in and the operator to become familiar with machine responses under working conditions whilst operating at a relatively slow speed.

If possible select a first days work that will provide a majority of light to average cutting with only occasional heavy duty work.

During this period check that nuts and bolts are tight after one hour, four hours and again at the end of the day.

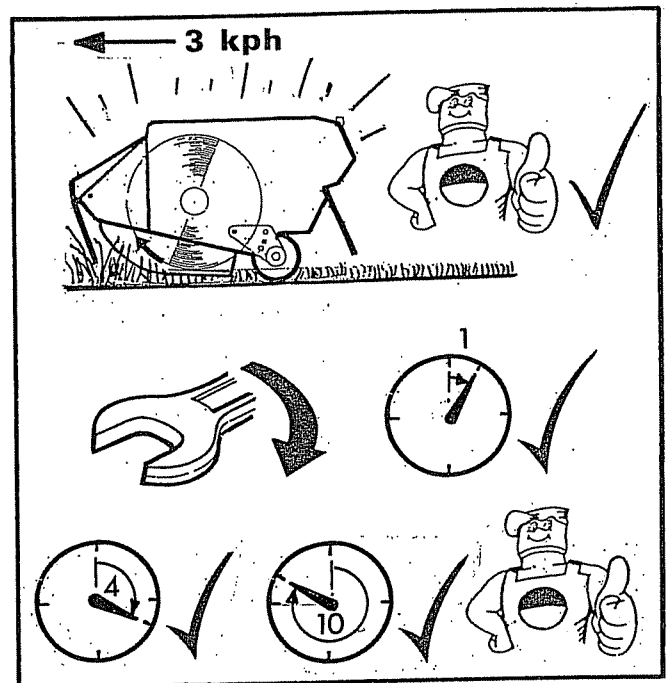

## CUTTING PRECAUTIONS

Inspect the work area, remove any hazardous material and note any immovable obstructions.

If the type of work being undertaken makes this important precaution impractical always maintain a high degree of alertness and observation and restrict the tractors forward motion to a speed which will allow the operator to stop the tractor before contact is made with any hazard!

## GENERAL WORKING PRACTISES

It is the operators responsibility to develop safe working procedures.

### ALWAYS:-

Be aware of hazards in the vicinity.

Make sure all guards are in position and in good condition.

Disengage P.T.O. before stopping the engine.

Wait until the flail has stopped running before leaving the tractor seat.

Disengage the P.T.O. and stop the tractor engine before making any adjustments.

Check frequently that all nuts and bolts are tight.

Keep bystanders at a safe distance.





A

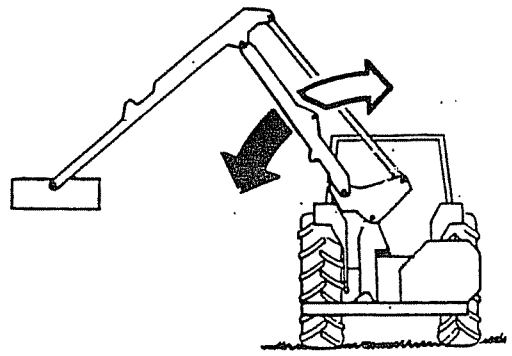

A

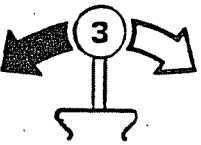
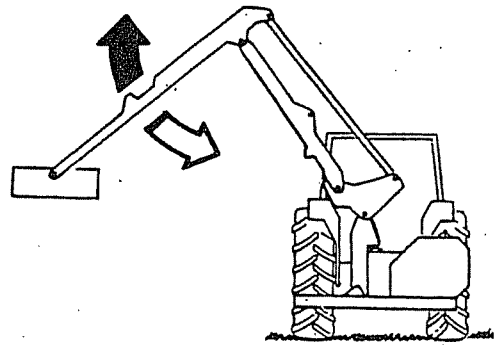

A

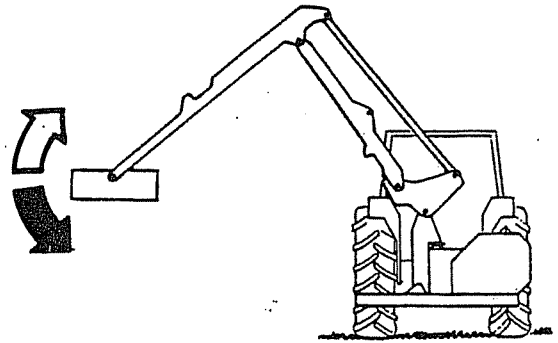

A

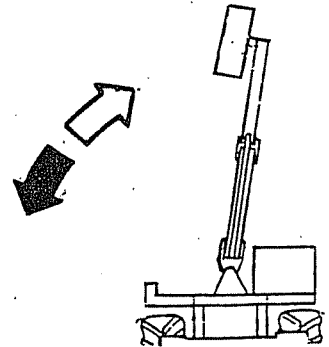

A

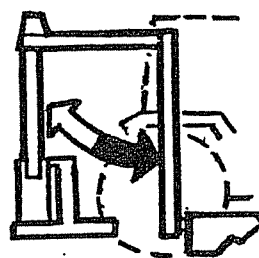



A Power on/off.  
On monolever controls turn clockwise for 'on' and push down for 'off'

B

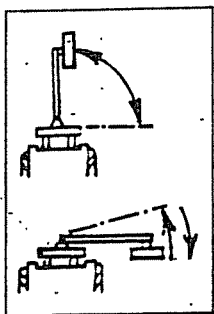

Slew - allows slew working

Auto reset - allows normal working

C Lift float on/off - if fitted

D Angle float on/off

E Head float on/off - if fitted

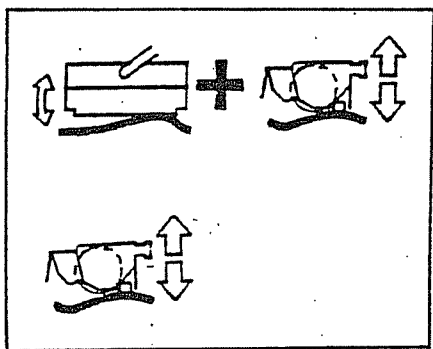

Allows lift and angle float in unison.

Allows lift float selection alone.

F Oil flow to power motor 'on' and reset switch - responsible for rotor rotation.

For the rotor to function the switch must be in the 'on' position. This switch can be used to stop and start the rotor even if the rotor control switch is not deselected.

Following the selection of "main power on" or "rotor reverse" the switch must be pushed into and held momentarily (2-3 secs) in the reset position before the switch position is reversed to select oil flow to the motor.

G Rotor on/off.

**BEFORE SELECTING OPPOSITE ROTATION ALLOW ROTOR TO STOP COMPLETELY**

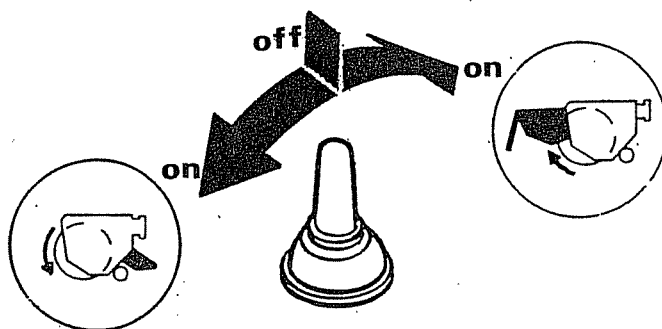

**PROPORTIONAL ARMREST CONTROLS - v.3**

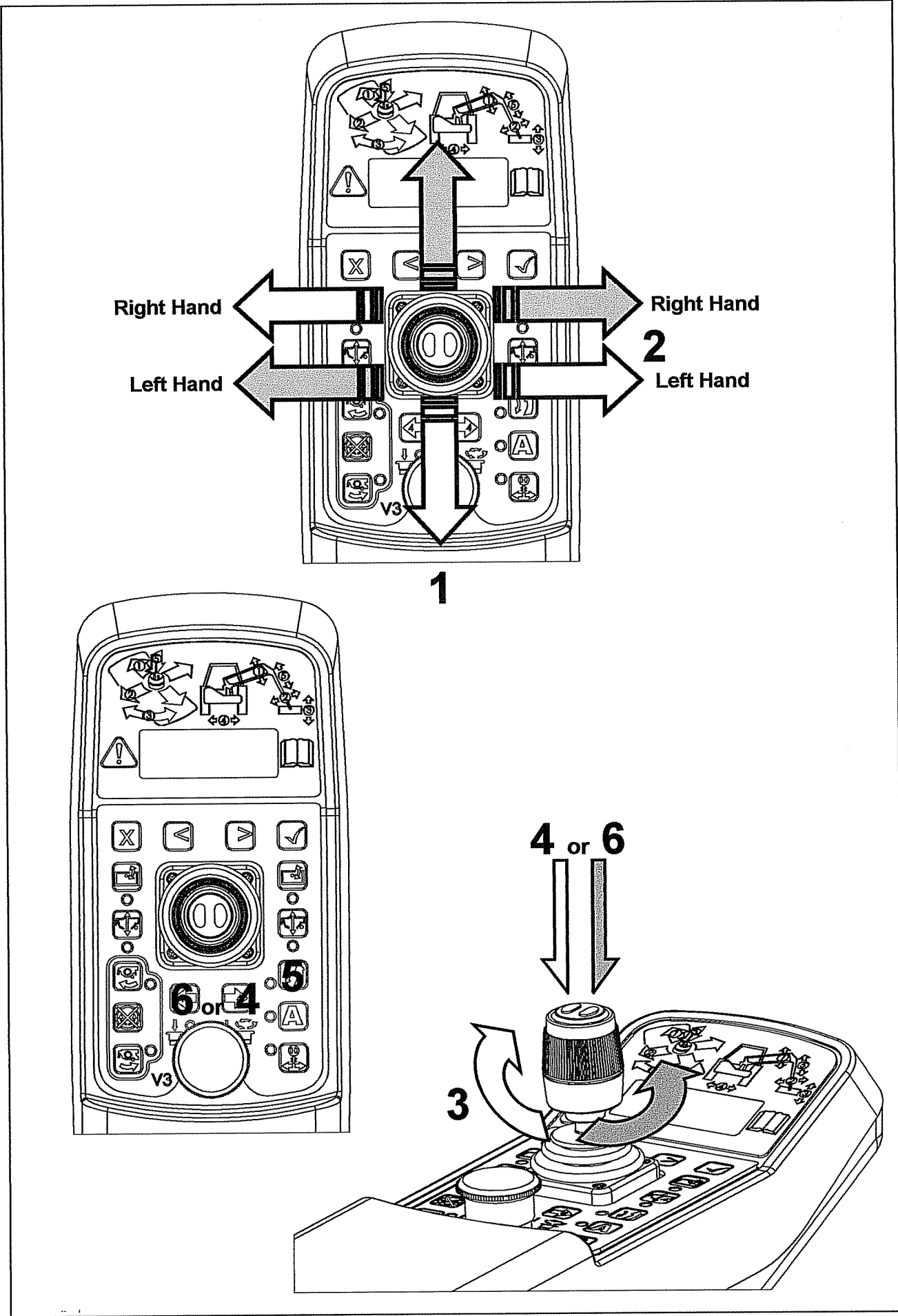

1

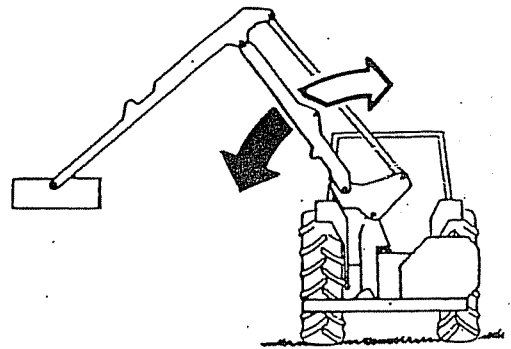

2

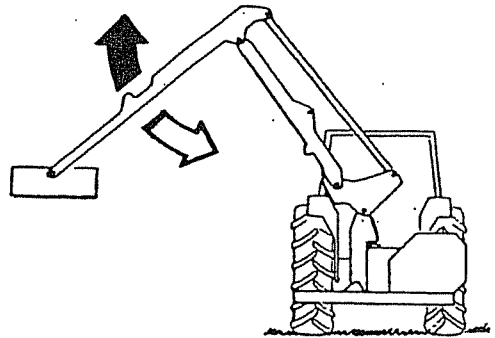

3

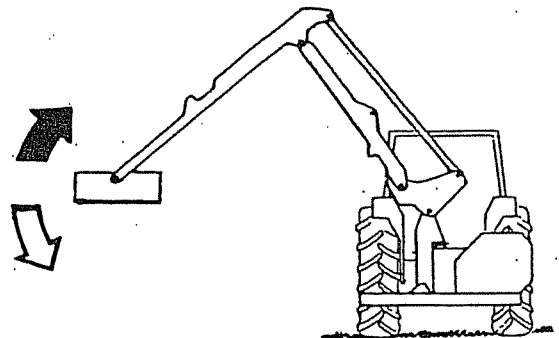

4

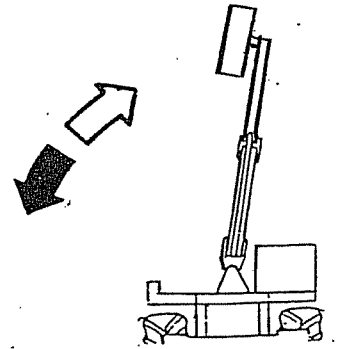

5

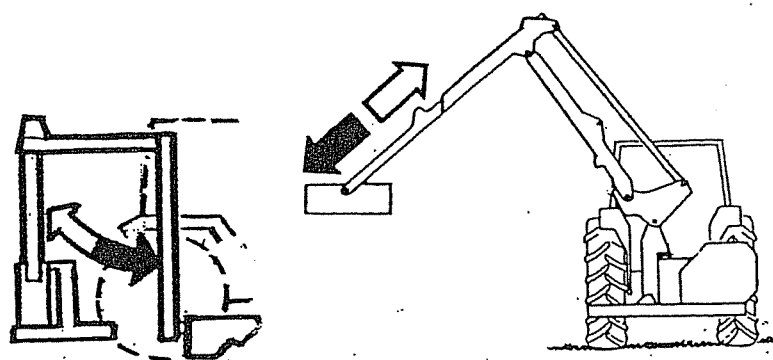



# SWITCH LOCATIONS - v.3 Proportional Armrest Controls

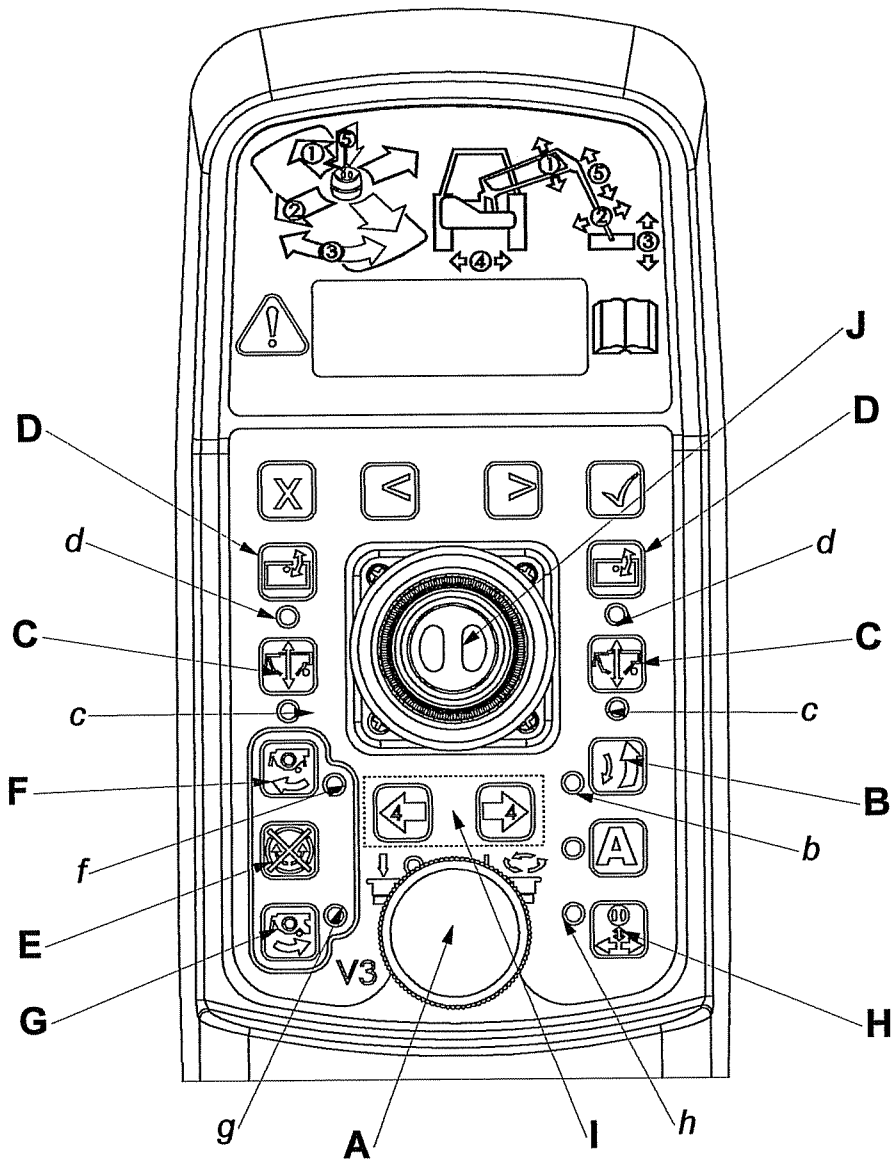

SWITCH	FUNCTION	L.E.D.
A	Power ON/OFF - Turn clockwise for ON, Push for OFF	-
B	Auto Reset	b
C	Lift Float	c
D	Head Angle Float	d
E	Rotor Off	e
F	Rotor On - Upward Cutting	f
G	Rotor On - Downward Cutting	g
H	Tele/Slew Swap - determines operating mode of: I & J	h
I	Slew Operation - H deactivated	h OFF
J	Tele Operation - H deactivated	
I	Tele Operation - H activated	h ON
J	Slew Operation - H activated	

Note: The mode selection of H is retained in the circuit memory when powering on and off, it does not deselect when the unit is switched off and on.

## SWITCH FUNCTIONS - v.3 Proportional Armrest Controls

<u>SWITCH</u>	<u>FUNCTION/OPERATION</u>
SWITCH 'A'	<b>POWER ON/OFF</b> <i>Turn clockwise for 'ON' and push down for 'OFF'</i>
SWITCH 'B' (L.E.D. light 'b')	<b>AUTO RESET</b> <i>Press down to select 'auto reset' (i.e. normal working). Pressing either 'Slew' buttons will de-select 'Auto Reset' and allow 'Slew' operation. 'Auto Reset' will have to be reselected if required.</i>
SWITCHES 'C' (L.E.D. light 'c')	<b>LIFT FLOAT</b> <i>Press either switch to select or deselect the 'lift float' function. When 'lift float' is selected operating the lift service will override the float operation. On completion of the arm adjustment 'lift float' will automatically be reinstated.</i>
SWITCHES 'D' (L.E.D. light 'd')	<b>HEAD ANGLE FLOAT</b> <i>Press either switch to select or deselect the 'head angle float' function. When 'angle float' is selected operating the angle service will override the float operation. On completion of the head adjustment 'angle float' will be automatically reinstated.</i>
SWITCHES 'E', 'F' & 'G'	<b>OPERATIONAL ON MACHINES WITH ELECTRIC ROTOR ON/OFF CONTROL ONLY</b>
SWITCH 'E'	<b>ROTOR OFF</b>
SWITCH 'F' (L.E.D. light 'f')	<b>ROTOR ON - UPWARD CUTTING</b> Press to select
SWITCH 'G' (L.E.D. light 'g')	<b>ROTOR ON - DOWNWARD CUTTING</b> Press to select
REVERSING ROTATION:	<b>TURN ROTOR OFF</b> <i>WAIT until Rotor has STOPPED</i> <b>Select opposite rotation</b>
SWITCH 'H' (L.E.D. light 'h')	<i>Press switch 'H' to swap the operation controls of the Slew' and 'Tele' (red light appears). The Control box will remember this mode when the controls are turned off and will remain in the same mode when next switched on.</i>
SWITCHES 'I' & 'J'	<b>SLEW &amp; TELE or TELE &amp; SLEW</b> <i>dependent on mode of Switch 'H'</i>

## SCREEN DISPLAY AND FUNCTIONS

Twist E/stop on armrest controls to power on and the screen will light up. Note: 12Volts at the battery are required for correct function.

1. The screen will initially display the McConnel logo, software version and the PTO maximum speed.

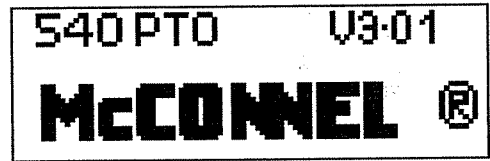

2. Pressing scroll forward once will display the running screen. The TOT displays the total time the rotor has been switched on. The JOB also displays the rotor on time but may be reset to zero by pressing the X button for 3 seconds.



3. Pressing either of the Rotor ON buttons will activate the 'egg timer' and rotor image.



4. Pressing the EDS Lift float button will turn on the EDS (EDS Lift Float machines only). Then SOFT, MED or HARD will be added to the running screen.

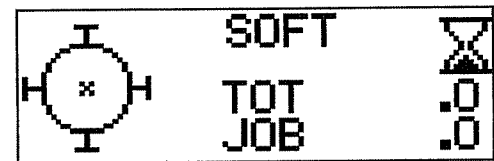

5. Pressing ✓ while the EDS is turned on will scroll through the SOFT, MED and HARD working settings.

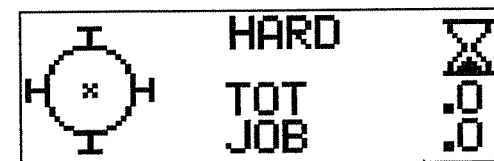

6. Pressing scroll forward displays the actual Tractor PTO running speed

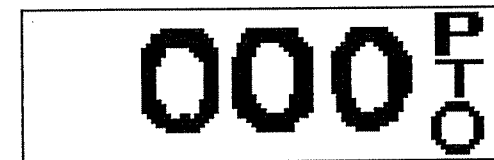

7. Scrolling forward again displays the Power Monitor screen.



Scrolling backwards will display the screens in the opposite order.



## BREAKAWAY

The machine is fitted with a hydraulic breakaway device which protects the structure of the machine should an unforeseen obstacle be encountered.

**Note:-** The breakaway function does not relieve the operator of his responsibility to drive carefully, be alert and to avoid obvious hazards before contact occurs.

Breakaway may occur momentarily during normal work should an extra thick or dense patch of vegetation be encountered. In these instances tractor forward motion may be maintained with care.

Where breakaway has occurred as a result of contacting a post or tree etc. the tractor must be halted and the controls of the machine utilised to manoeuvre the head away from the obstacle. **NEVER CONTINUE FORWARD MOTION TO DRAG THE HEAD AROUND THE OBSTACLE IN BREAKBACK POSITION.**

**Note:-** The force required to activate the breakaway system will vary dependent upon the gradient of work. It will require less force when working uphill and vice versa.

On midcut machines the geometry of the breakaway will cause the head to initially move outwards in addition to rearwards. Therefore be aware that the breakaway action will be impeded if the outer end of the head is working against a steep bank. In this circumstance extra care must be taken during operation to avoid this occurrence.

Breakaway occurs at the slew column pivot. When an obstacle is encountered continued forward motion causes the pressure in the slew ram base to rise until the relief valve setting is exceeded:

**With 'AUTO RESET' selected:-**

When the slew relief valve setting is exceeded oil is displaced from the slew ram into the base of the lift ram which causes the head to rise as the arm pivots backwards to clear the obstruction. Re-setting of the head into the work position occurs automatically.

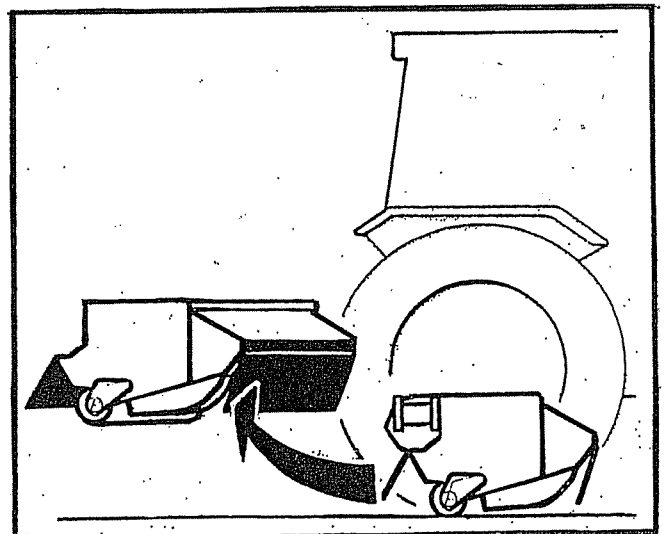

**With 'SLEW' selected:-**

When the slew relief valve setting is exceeded oil is displaced from the slew ram allowing the arm to pivot backwards horizontally and the obstacle to be cleared.

Re-setting the head into the work position is carried out manually by selecting 'SLEW OUT' on the control assembly.

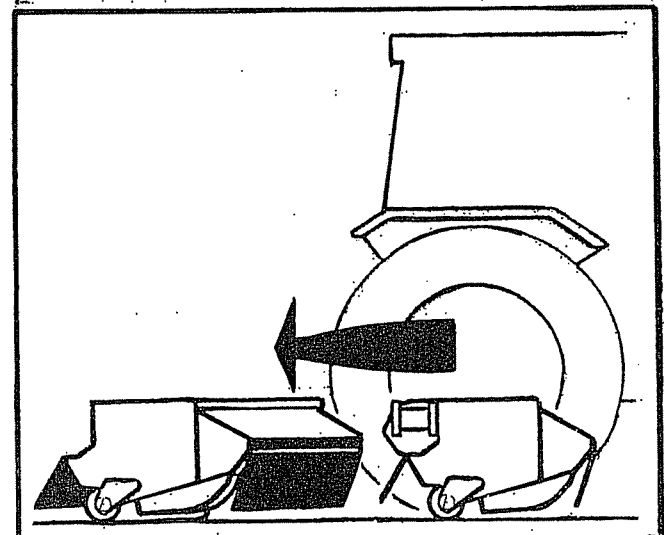

## POWERED SLEW

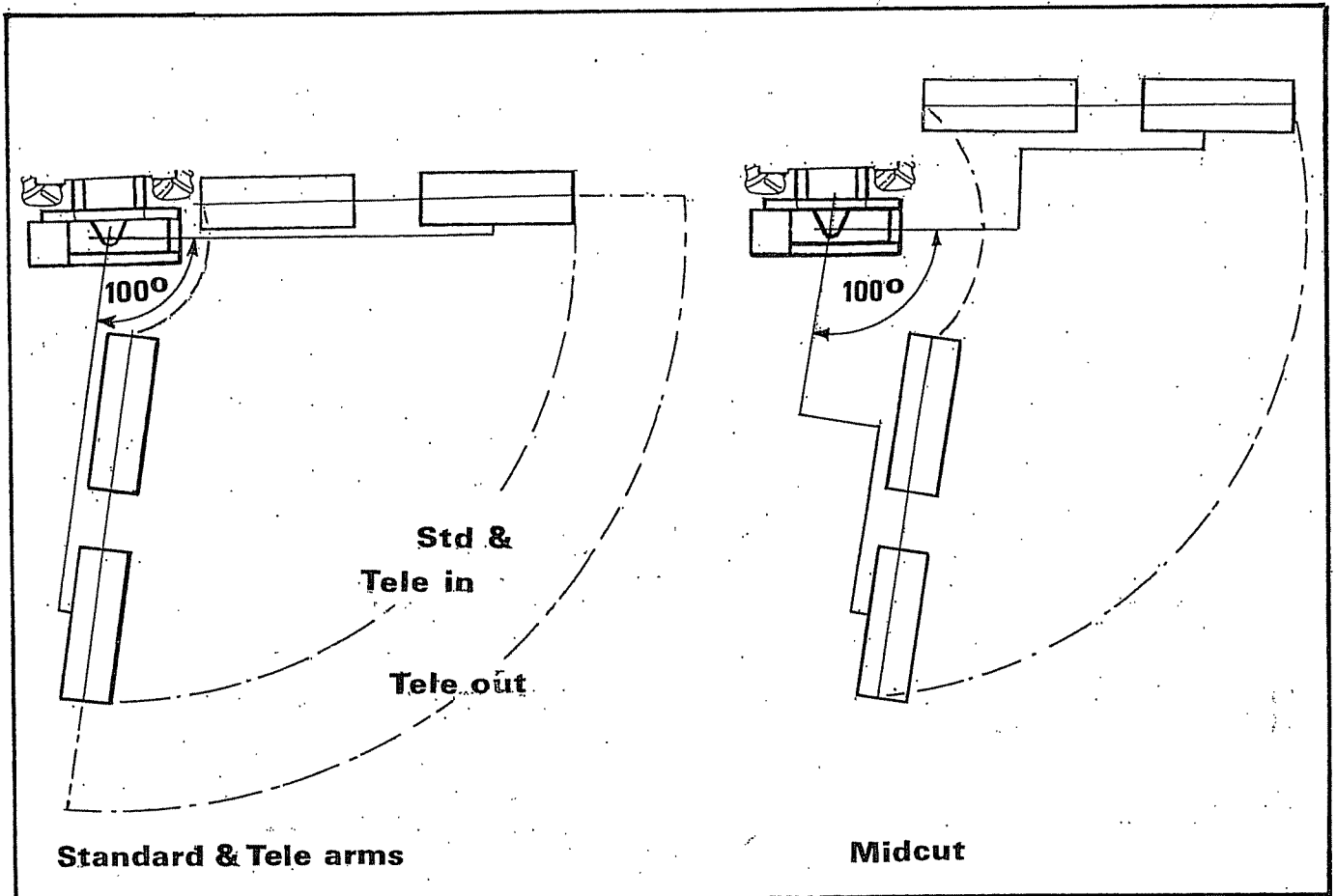

The slew feature allows a  $100^\circ$  arc of powered arm movement on the working side from right angles to the tractor to  $10^\circ$  beyond the direct line astern.

the feature is required to place the machine in the transport position but can also be used to sweep the arm to and fro whilst cutting awkward areas and corners thus avoiding the need to constantly re-position the tractor.

To operate in this way 'SLEW' must be selected on the control assembly.

If breakaway occurs the slew motion must be reversed to allow the slew breakaway relief valve to re seat and the ram to become operable again.

**Caution:** Extra care must be taken when working in 'SLEW' mode with the reach fully in as it is possible for the flail head to bit the tractor or machine frame.

## PARALLEL MOTION GEOMETRY

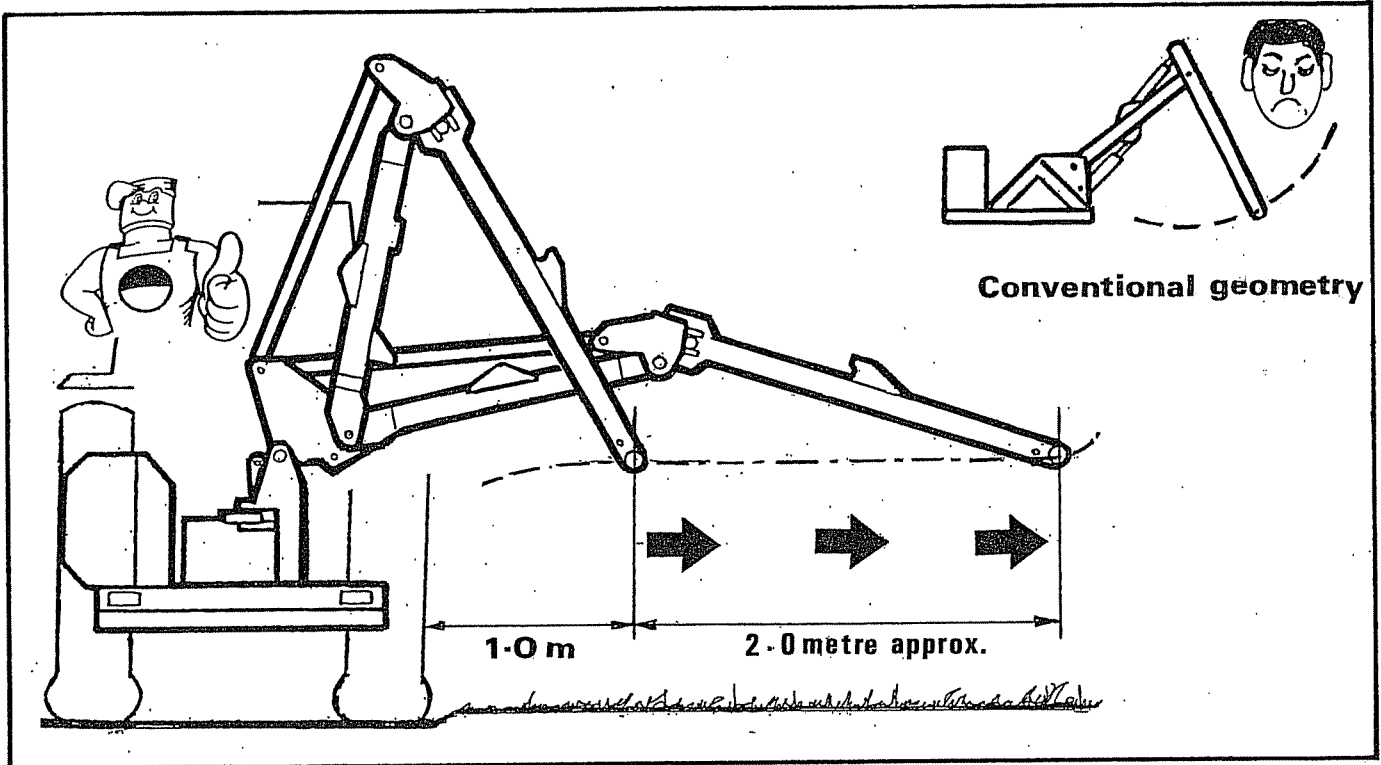

This feature enables the operator to adjust the reach of the machine in and out without having to continuously adjust the lift service to compensate for the change in head pivot height as is the case with traditional geometries.

**Note:-** The performance of the feature is at its most accurate during the mid range of the reach travel with some deterioration in performance being experienced when the outer extremities of reach adjustment are approached.

## ANGLE FLOAT

The selection of angle float on the control box simultaneously connects both gland and base side of the angling ram to tank.

The ram rod can then extend and retract freely allowing the flail head to automatically follow the contours of the ground.

Angle float is an "operator friendly" mowing feature and can be used singly or in conjunction with lift float.

**Note:-** for the feature to work to its maximum capabilities the head must be mounted such that it is balanced about the pivot

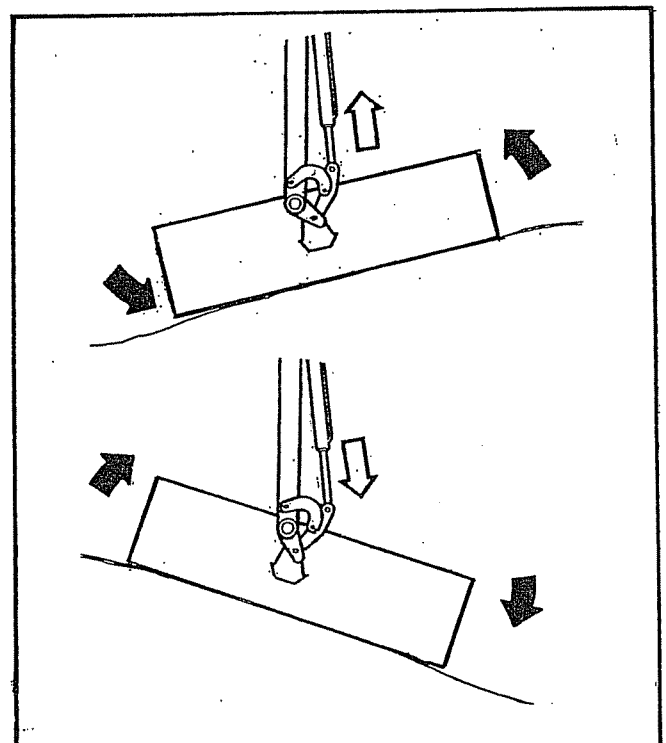

## TELESCOPIC DIPPER PA5000T/7000T only

Hy-Reach 650T - The telescopic dipper gives up to 1.05 metres of reach extension.

Normally the tele is pre-set and then the machine operated using the normal controls. The 'Tele' function could be used in place of 'Reach' but a slower response to the controls must be expected.

'Tele' alters the parallel motion geometry. This works best at ground level when 'tele' is fully out and at 4-5 feet (1.2 - 1.5 metre) high when fully in.

### WIRE TRAP

The flail head is equipped with a wire cutting edge welded into the underside. This is to ensure that the ends of any wire that may be entwined in the rotor are cut and do fall within the confines of the flail head. This plate should not be interfered with in any way.

Any wire caught in the rotor must be immediately removed.

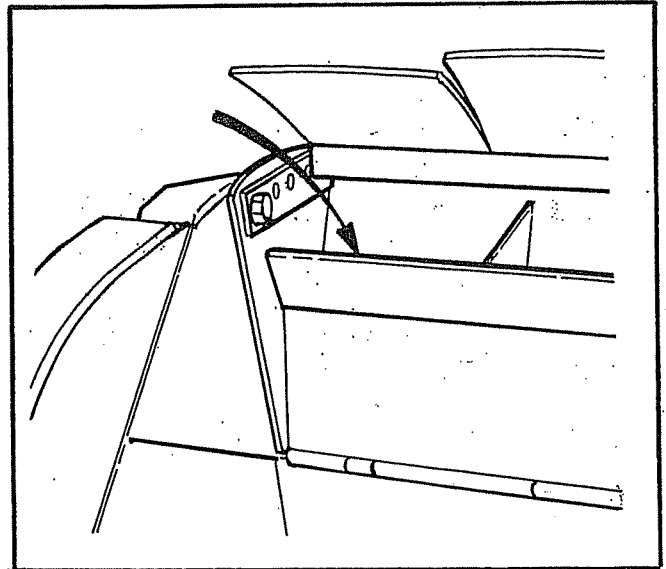

### REMOVING WIRE

Select rotor "OFF" and wait until it has stopped rotating.

STOP the tractor and only then remove wire.

Do not reverse the rotor in an attempt to unwind any wire.



## FLAIL SELECTION

Four types of flail are available to provide the optimum cutting characteristics for the type of work being carried out.

Designed specifically for general mowing activities

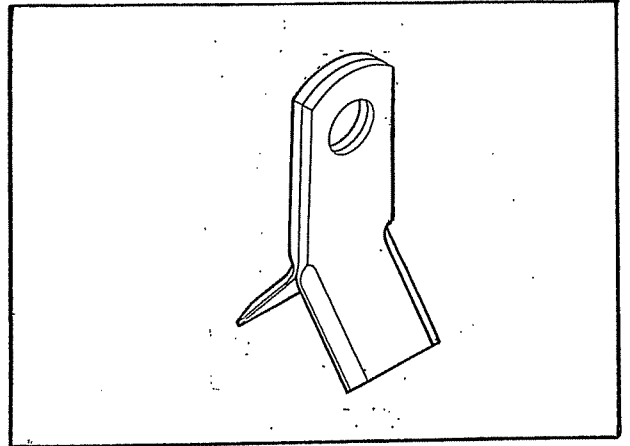

Designed specifically for heavy duty hedge cutting this flail is capable of dealing with material up to 75/80mm dia. These flails also provide a good mowing finish but will require considerably more power when used for this purpose.

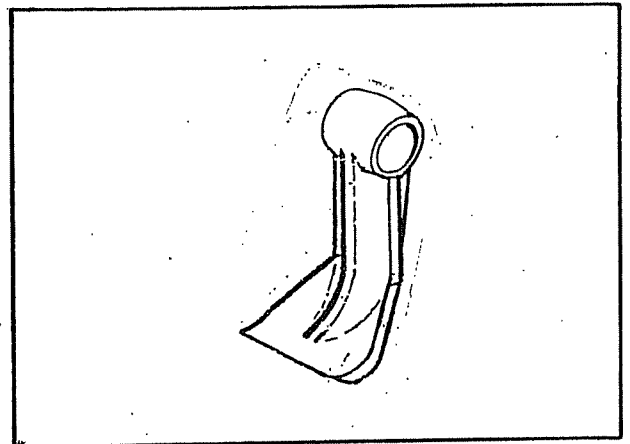

Designed for general purpose work they are suitable for both mowing and the cutting of hedges with up to two years growth

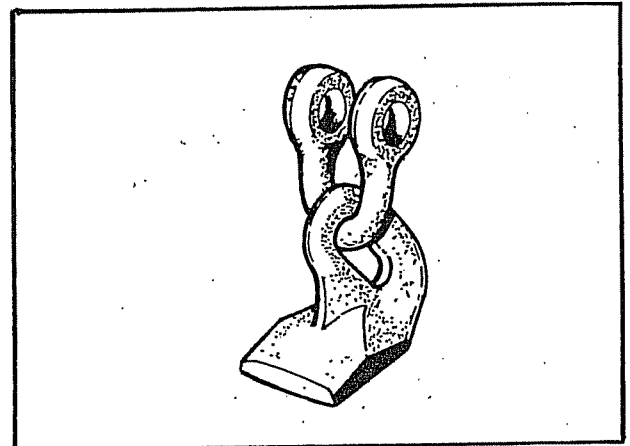

Designed specifically for heavy duty hedge cutting this flail is capable of dealing with material up to 75/80mm dia. These flails also provide a good mowing finish but will require considerably more power when used for this purpose.

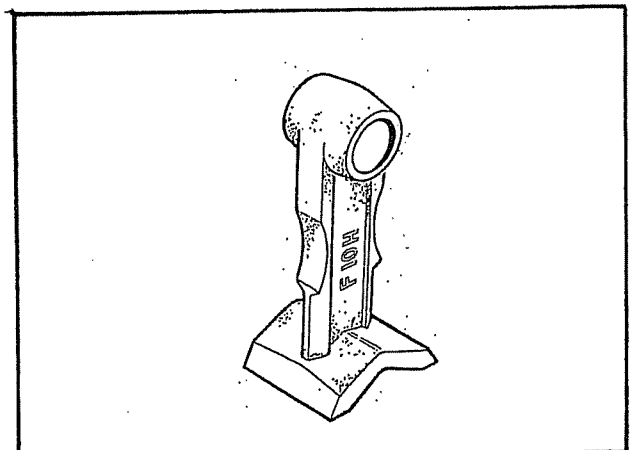

## MOVING INTO THE TRANSPORT POSITION (standard arm and telescopic models)

Select "ROTOR OFF" and wait until the rotor has stopped turning.

Ensure that the lift and angle float are switched off.

On tele models only operate "TELE IN" and fully retract tele arm.

Place the transport pin in the "slew lock" location A

Select "SLEW" mode on the control assembly.

Operate "SLEW IN" until the transport lock pin drops into position

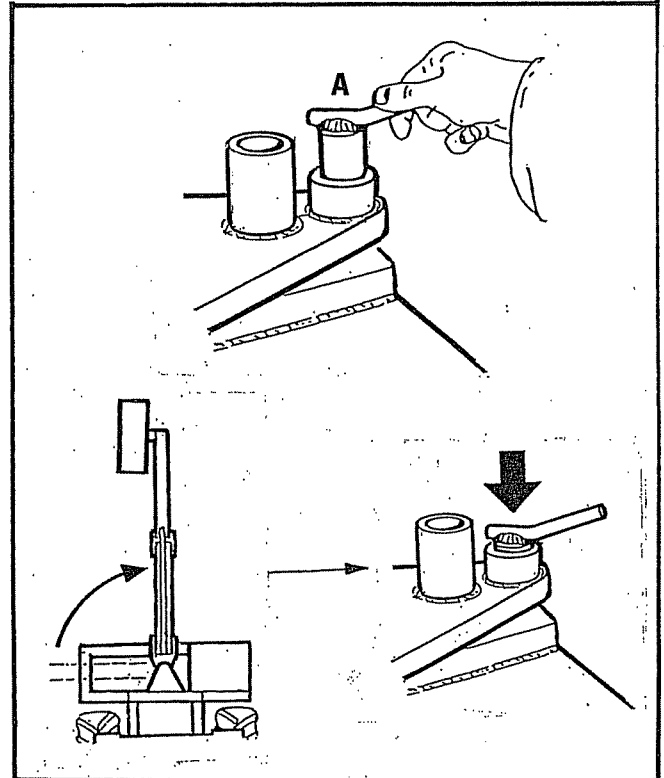

Pivot down the transport stay and pin in position

Operate "REACH IN" until the dipper arm contacts the stay on the main arm.

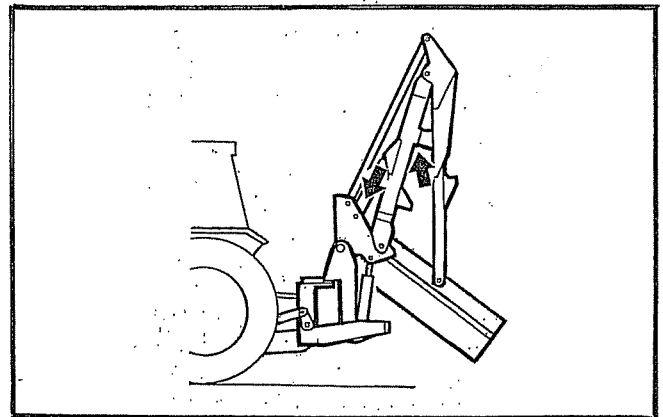

Operate "LIFT UP" and raise the arms until the tension link is 300mm from the tractor cab.

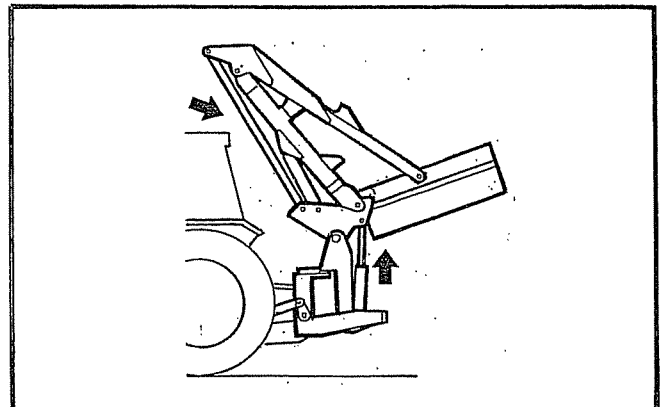

Operate "ANGLE" and position the flail head in as compact a position as possible - See "transport position".





## TRANSPORT POSITION

The machine is transported in line to the rear of the tractor with a minimum of 300mm clearance between the tension link and the rear cross member of the tractor cab.

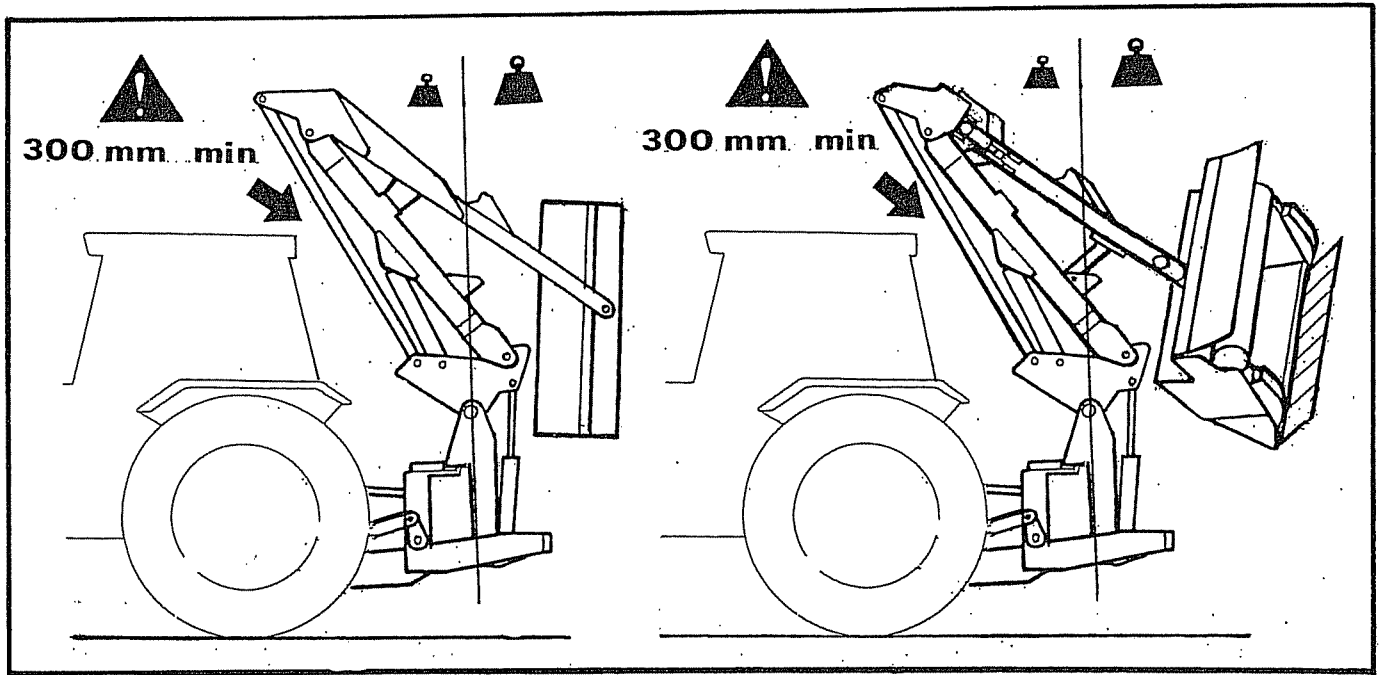

## TRANSPORT POSITION WITH HEAD REMOVED

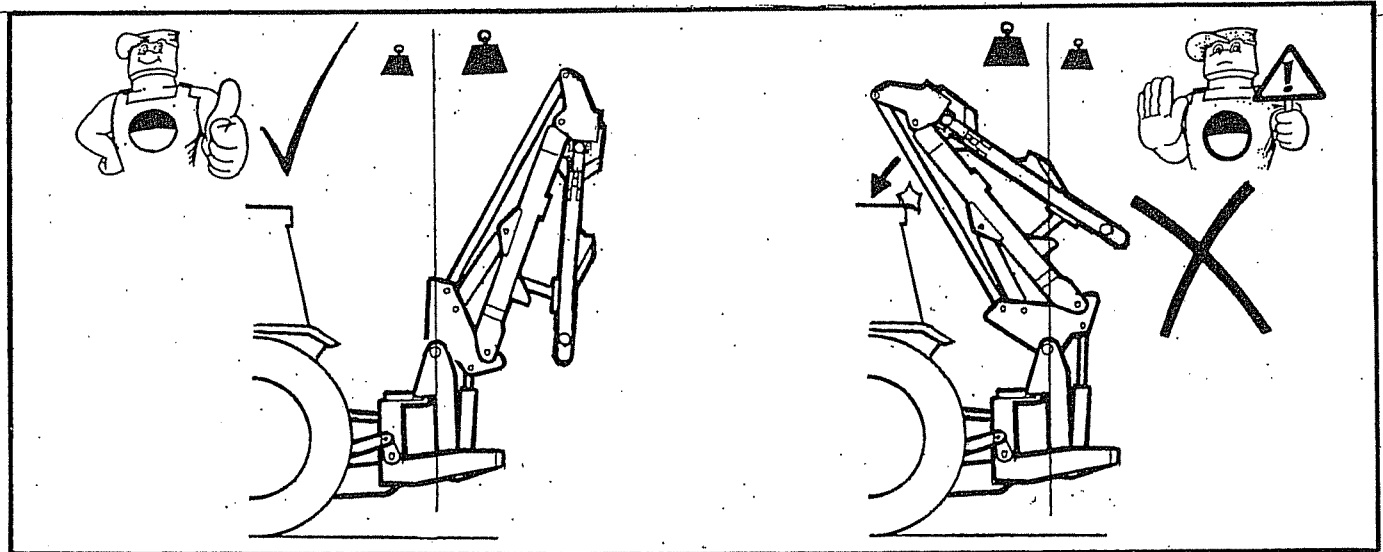

With the flail head removed the arms are fully folded but the lift ram remains retracted. If the lift ram is extended the weight of the arms will cause the balance of the machine to go over centre causing the tension link to crash into the rear cross member of the tractors cab.

### WARNING

During transport the transport lock device must always be used.

### WARNING

During transport the "SLEW" mode must always be selected on the control assembly.

## TRANSPORT

When in transport the P.T.O. must be disengaged and the power to the control box switched off.

The acceptable speed of transport will vary greatly depending upon the ground conditions.

In any conditions avoid driving at a speed which causes exaggerated bouncing as this will put unnecessary strain on the tractors top hitch position and increase the likelihood of the tension link contacting the cab rear cross member.

## TRANSPORT HEIGHT

There is no fixed dimension for transport height. It will vary depending on the height that the machine is carried and the degree of arm fold that the rear of the cab will allow.

For the majority of installations the transport height will generally fall between a minimum of 3.45m and a maximum of 3.75m when the machine is correctly folded.

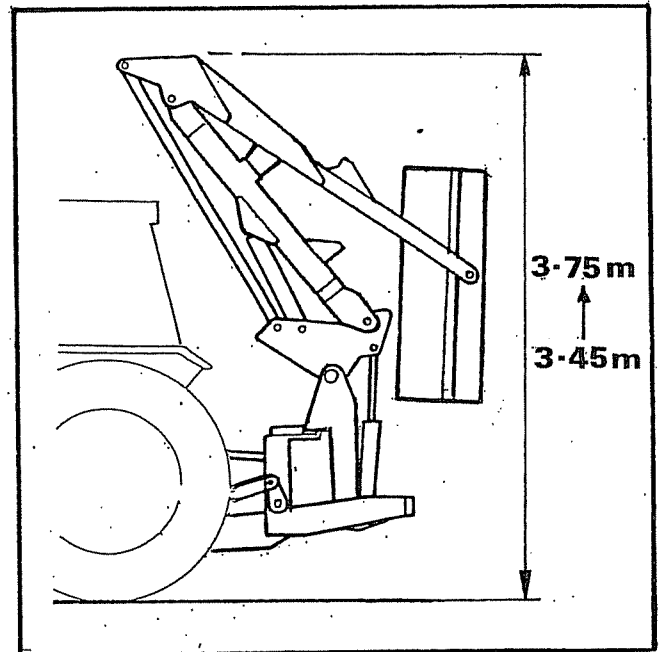

## MOVING FROM TRANSPORT TO WORK POSITION (all models)

To revert to the work position the previous procedures for the relevant models are largely reversed.

Remember to remove the transport pin from its "slew lock" position. It may be necessary to operate the slew controls to free the transport lock pin prior to removal and stowage

## ENGAGING DRIVE - Gear hydraulic machines only

Ensure that the rotor control lever is in the 'Stop' position before engaging the P.T.O. shaft. Allow the oil to circulate for a minute or so before operating the armhead levers. Position the flail head in a safe position, increase the engine speed to a high idle and move rotor control lever to 'START'. After initial surging the rotor will run at an even speed.

## ENGAGING DRIVE - Piston hydraulic machines only

Ensure the rotor control lever is in stop position.

Switch main power on.

Prime pump and switch pump power on.

Engage P.T.O. shaft.

Allow the oil to circulate for a few minutes.

Place the flail head in a safe position.

Increase engine speed to high idle and move rotor control lever to 'ON' selecting the rotation required. After initial surging the rotor will run at an even speed.

## ROTOR OPERATING SPEED

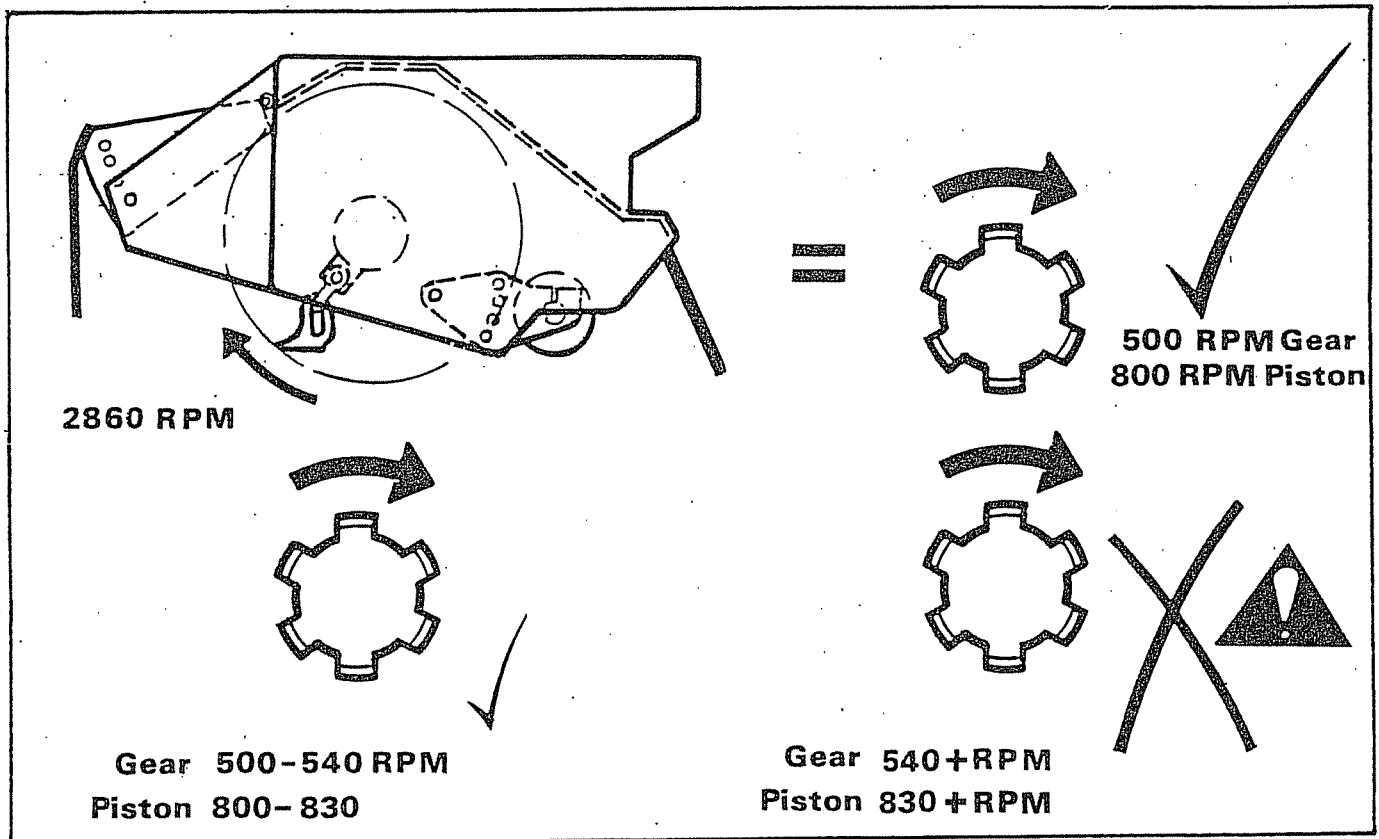

## OVERHEAD OBSTRUCTIONS

Always be aware the machine is approximately 4 metres high when folded and take care when manoeuvring in areas with overhead obstacles especially power cables, low bridges etc. or when entering buildings.

## TRACTOR FORWARD SPEED

Tractor forward speed is determined by the material being cut. Forward speed can be as fast as that which allows the flail head sufficient time to cut the vegetation properly.

Too fast a speed will be indicated by over frequent operation of the breakaway system, a fall off in tractor engine revs and a poor finish to the work leaving ragged uncut tufts and poorly mulched cuttings.

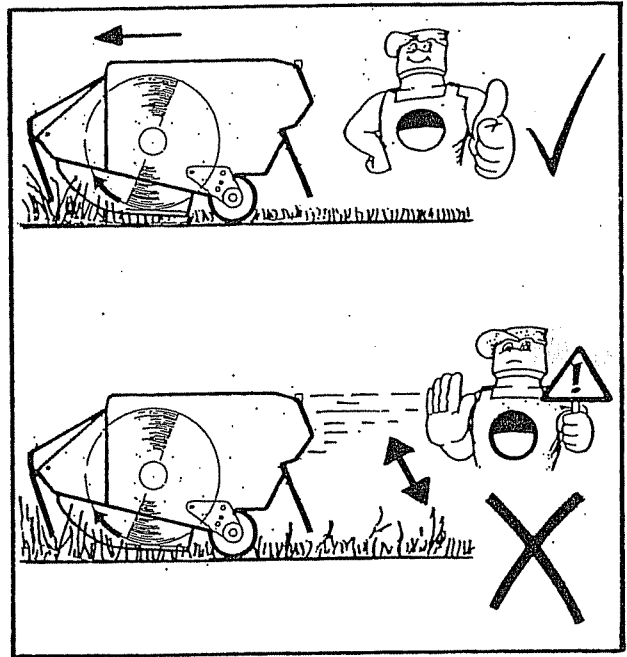

## WORKING ON PUBLIC HIGHWAYS

When working on the public highway it is the operator's responsibility to familiarise himself with any national and local regulations concerning this type of activity and to abide by them at all times.

In addition he must remember that there is a potential for debris to be thrown long distances should it escape the head shrouds.

In inhabited areas work should only proceed with extreme caution and any bystanders must be kept away from the potential danger area.

## HIGH VOLTAGE CABLES

### WARNING

Depending on the voltage of the cables and the weather conditions there is a danger of electric flashover if the head or arms approach the cables too closely.

Always maintain a minimum clearance distance of 1.5m when operating near high voltage cables.

If in any doubt consult your local electric company regarding a safe procedure for work.

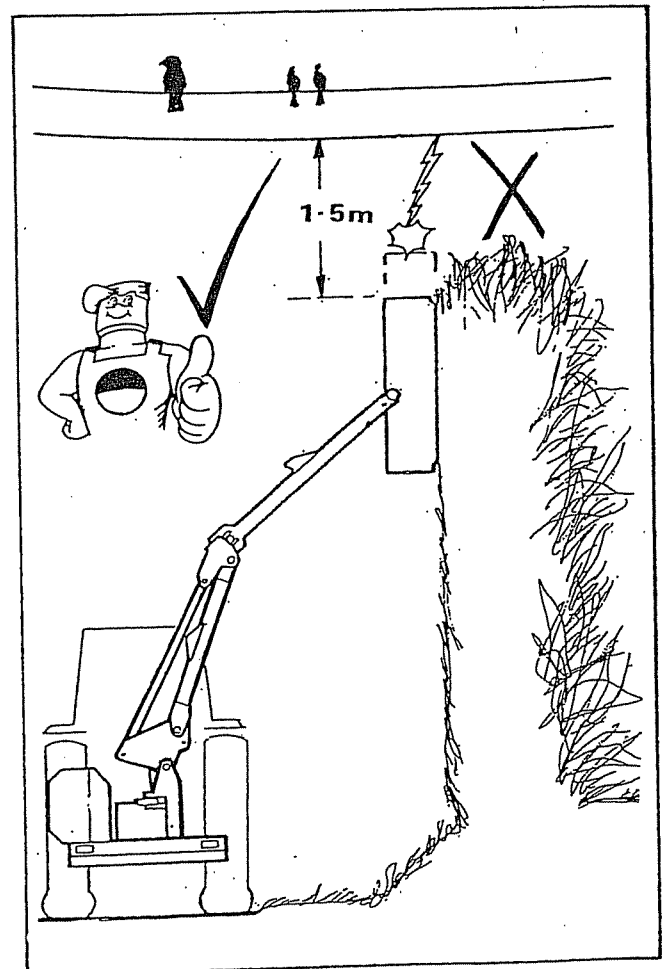



## HEDGE CUTTING PROCEDURE

1. Cut the side and bottom of the field side first. This leaves the maximum thickness of hedge on the road side to prevent the possibility of any debris being thrown through the hedge into the path of oncoming vehicles.

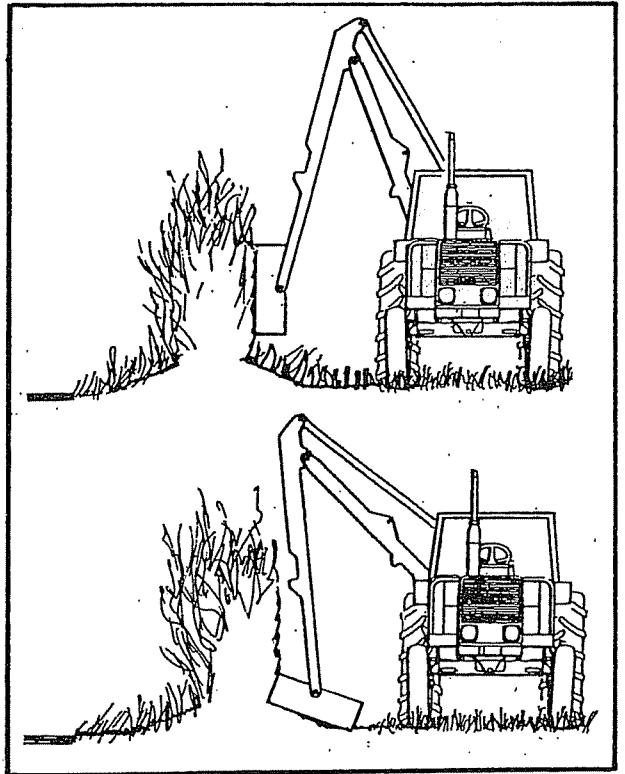

2. Cut the side and bottom of the road side.

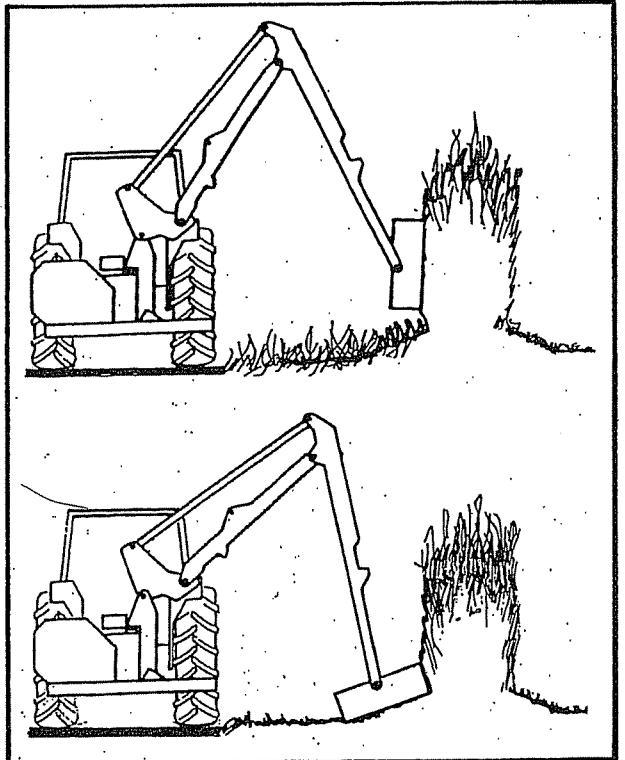

3. Top cut the hedge to the height required.

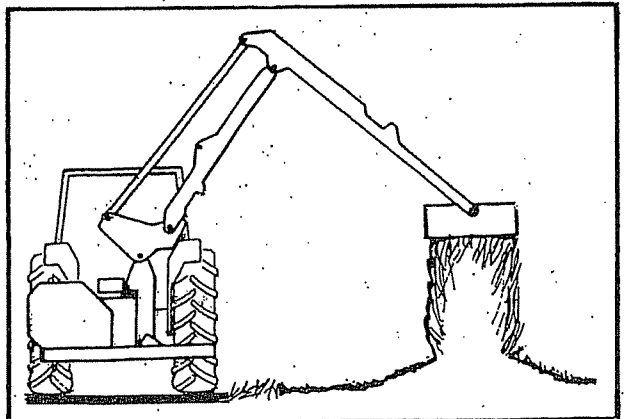

LIFT FLOAT KIT (optional extra for ground cutting)

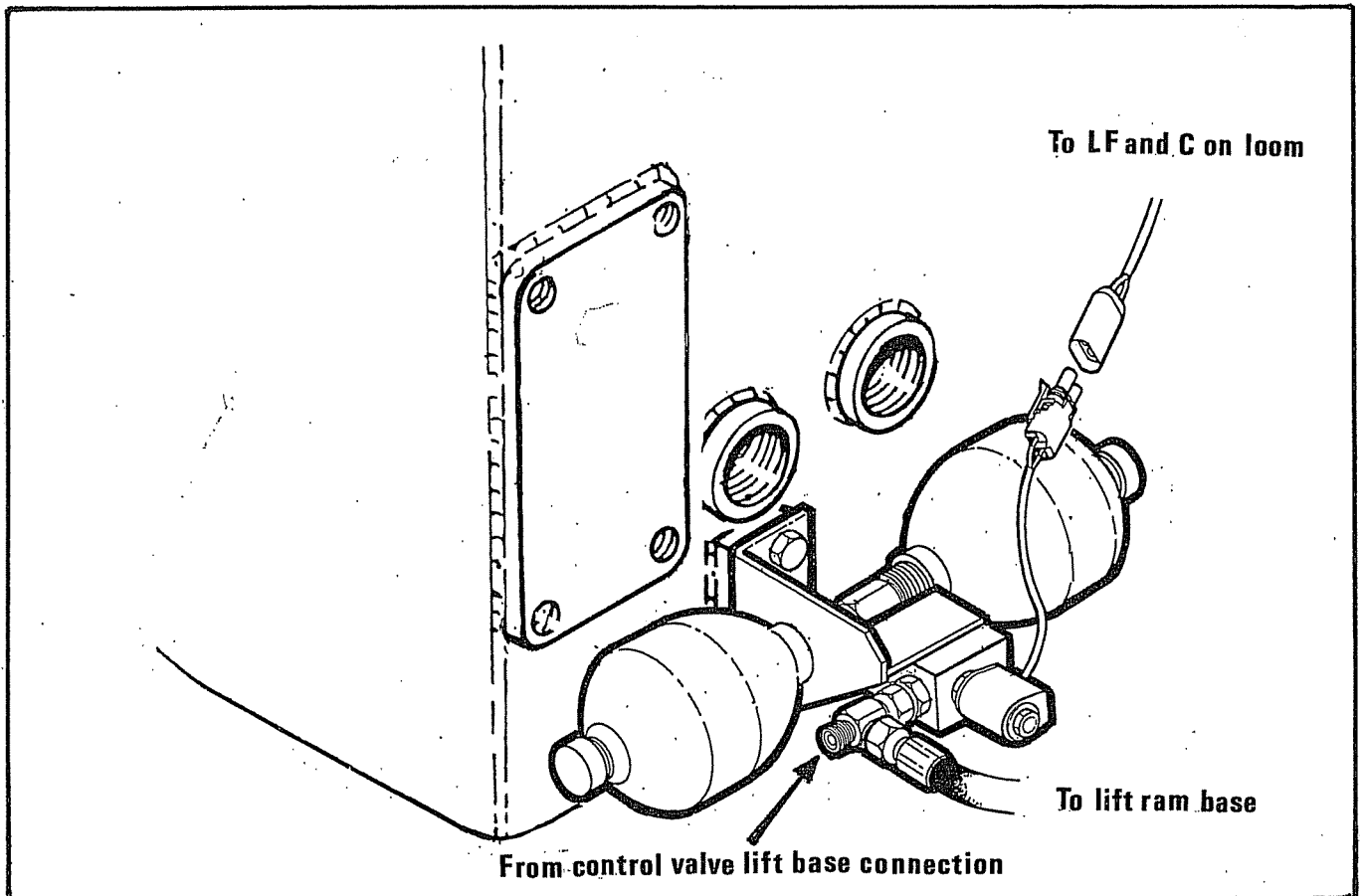

The lift float kit is mounted as shown

On electric controlled machines the cable from the poppet valve solenoid is connected to the auxiliary switch on the control unit. It is permissible to also have the angle float facility connected to the auxiliary switch. In this case both functions will operate in unison.

The auxiliary switch on multilever electric controlled machines is a three position type which will allow the selection of head float alone, or head and angle float in unison, if both options are fitted.

For multilever switchboxes an additional switching kit part number 84 02 303 is available which will, when the dual action position is selected, isolate the lift float function and allow angle float to be selected alone.

In work with the solenoid valve open the flail head will automatically follow the ground contours.

The float action is engaged by selection of auxiliary switch.

The lift control should be operated to take a proportion of the flail head weight off the flail roller. This is important, too little weight on the roller will leave areas of grass while with too much weight on the roller the ground will be scalped in places and increased flail wear, damage, or even loss of flails could occur.

To revert to standard operation the accumulator is isolated from the lift ram by deselecting the float switch.

LIFT FLOAT - electronic response - standard equipment on E.D.S. machines.

Prior to selecting lift float ensure the flail head is on the ground and deselected.

The lift float is selected by using either button designated for this purpose on the control console.

Once selected the system is automatic and requires no adjustments of the lift service by the operator.

The proportion of the flail head weight that is taken by the lift ram is preset by the manufacturer to provide the optimum ground following characteristics.

Should the weight of the flail head vary considerably i.e. changing from a 1.2m head to a 1.5m/1.6m head or vice versa contact McConnell Service Department to have your float response re-calibrated.

## REMOVAL FROM TRACTOR

### DANGER

READ CAREFULLY BEFORE COMMENCING TO REMOVE THE MACHINE FROM THE TRACTOR.

THE ORDER OF THE FOLLOWING STEPS MUST BE FOLLOWED EXACTLY

DISCONNECTING THE TOP LINK MUST BE THE LAST OPERATION PRIOR TO DRIVING THE TRACTOR AWAY FROM THE MACHINE.

#### WARNING

Do not operate quadrant lever or machine controls through the rear cab window whilst standing on or amongst linkage components. Always seek assistance.

Select a firm level site for parking the machine.

Lower the stand legs and fix in previously used position

Raise the machine of the tractors linkage until the weight is taken off the stabiliser

Remove the stabiliser nose quadrant locking pin

Lower the machine to the ground

Operate machine controls and place the flail head on the ground to the rear at half reach

Disengage tractor P.T.O. and remove the drive shaft

Unbolt the control unit from the mounting pillar, remove from tractor cab and stow the lever or switchbox clear of the ground.

Disconnect the stabiliser from the tractors top hitch position.

Remove draft link pins and drive tractor away

### STORAGE

If machine is to be left standing for an extended period of time, lightly coat the exposed portions of the ram rods with grease. Subsequently this grease should be wiped off before the rams are next moved.

If the machine has to be stored outside tie a piece of tarpaulin or canvas over the control assembly do not use a plastic fertilizer bag which could lead to rapid corrosion.

## SUBSEQUENT ATTACHMENT

Reverse tractor to machine and connect draft link

Fit P.T.O. drive shaft and attach torque chains to prevent guards rotating

Fit stabiliser into tractors top hitch position

Place controls in cab

Raise machine on tractors linkage and fit the stabiliser nose quadrant locking pin

Tighten check chains and/or stabiliser bars

Remove the transport lock pin and stow

Operate machine controls and place arms in the work position at half reach with the head clear of the ground

Adjust lift arm levelling box until the frame is horizontal

NOTE:- When fitting to the same tractor the same mounting locations can be used. When fitting to different tractors the stabiliser may need to be re-located. Also check the P.T.O. measurement to ensure a minimum of 150mm shaft engagement when in the work position

# MAINTENANCE

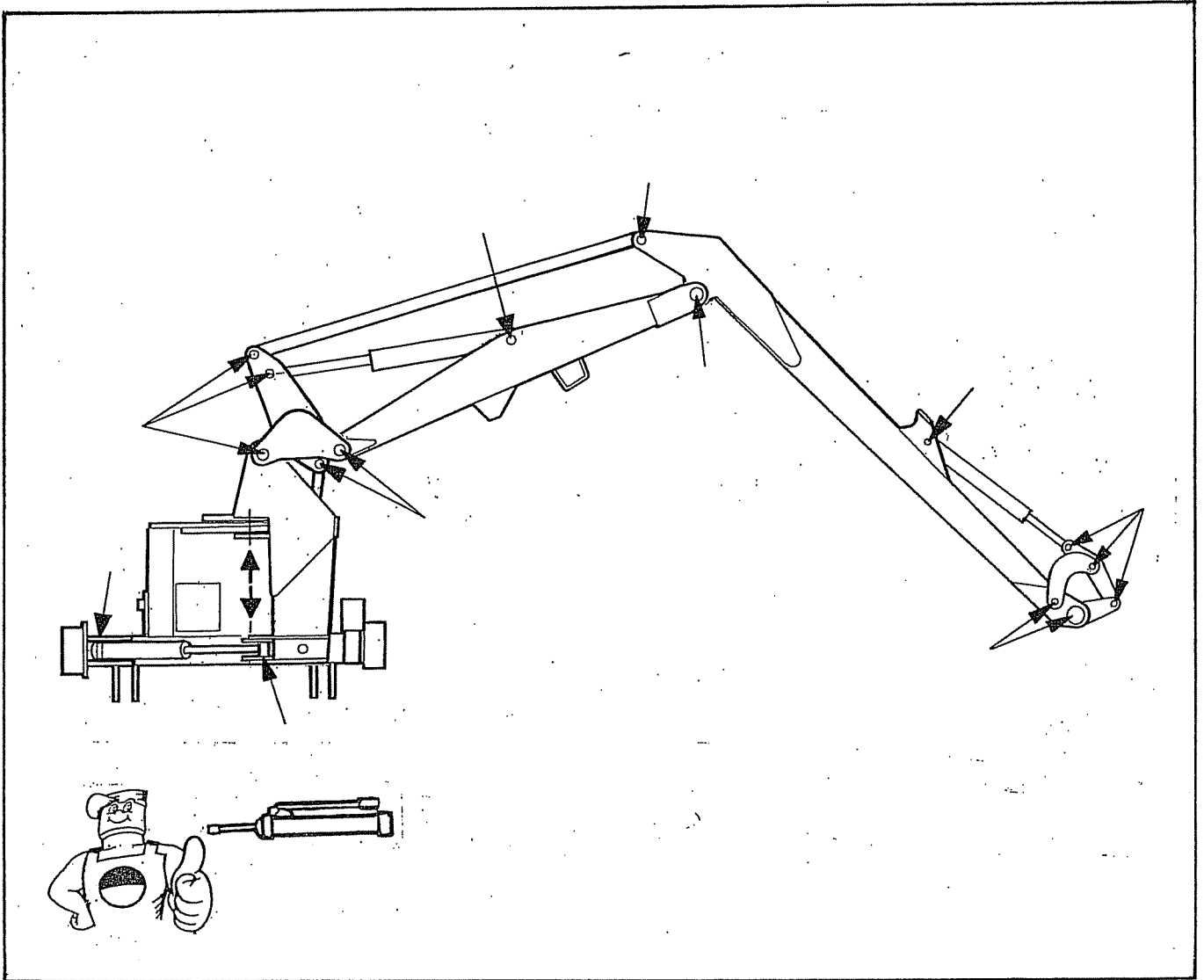

## LUBRICATION

### General

Grease daily all points shown.

## P.T.O. SHAFT

Regularly check the P.T.O. guards for damage and ensure the anti rotation chains are in place and that their anchor points are in good condition.

Do not operate the machine with any damage to guards, replace suspect items immediately.

### Lubrication

Lubricate the shaft at the points shown below at the intervals indicated using a general purpose lithium based grease.

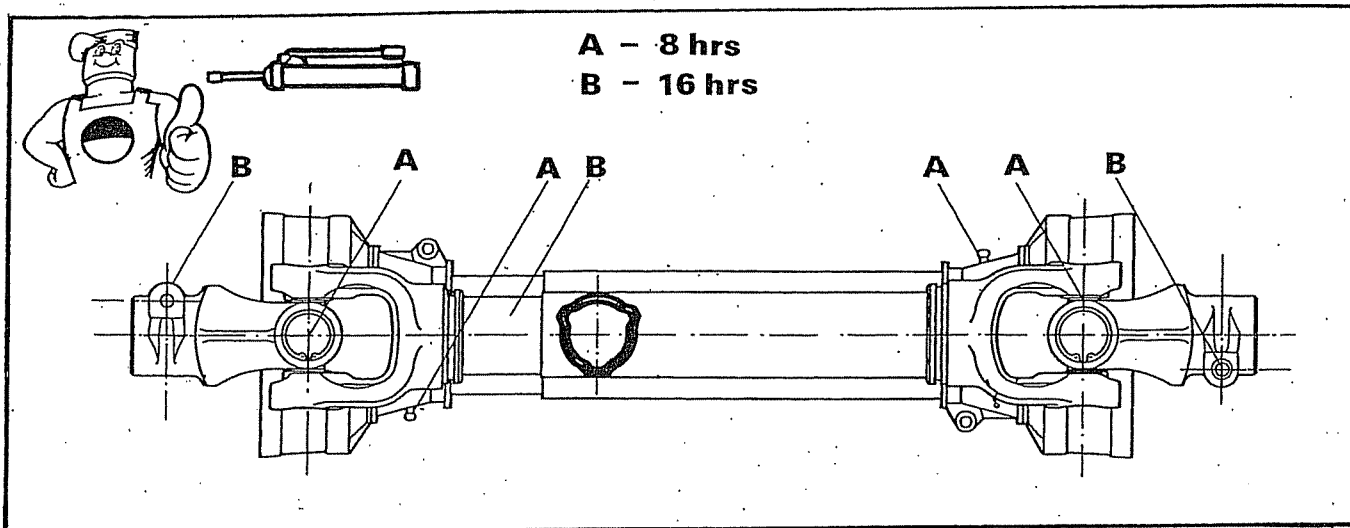

## CUTTING P.T.O. SHAFT

Separate the two P.T.O. half shafts from one another.

Turn the three guard fixing screws for each shaft half through 90°.

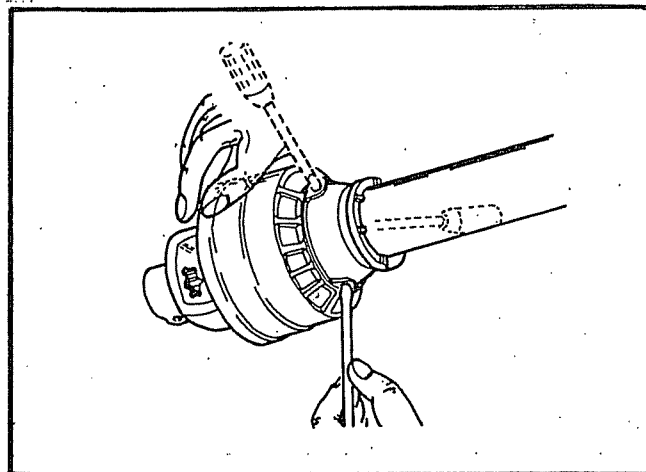

Extract the three screws for each shaft half.

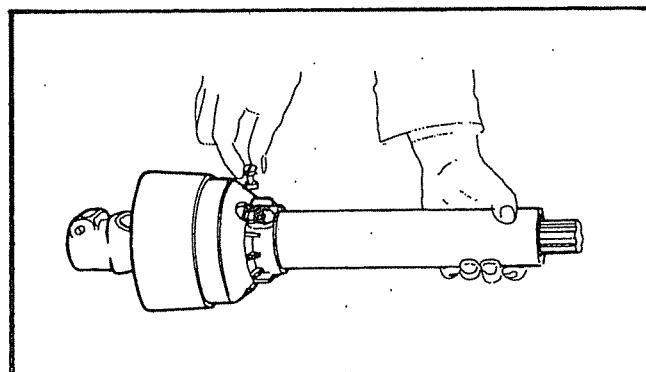

Separate the shafts from the guards/

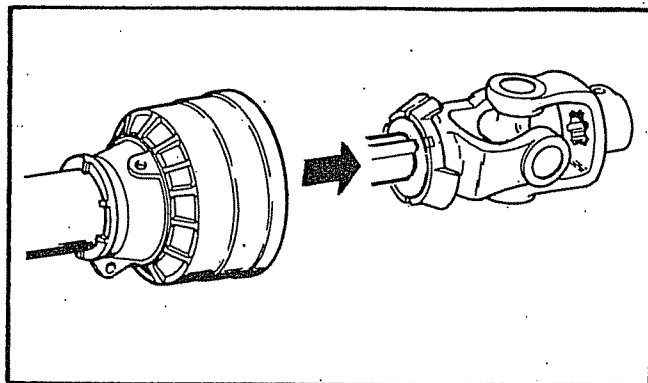

Cut the calculated shortening amount off both driver and driven shaft halves to give the required P.T.O. length.

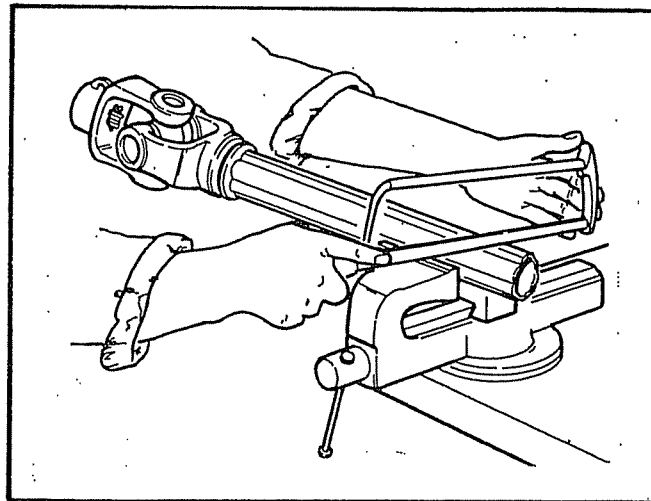

De-burr the ends of the cut shafts.

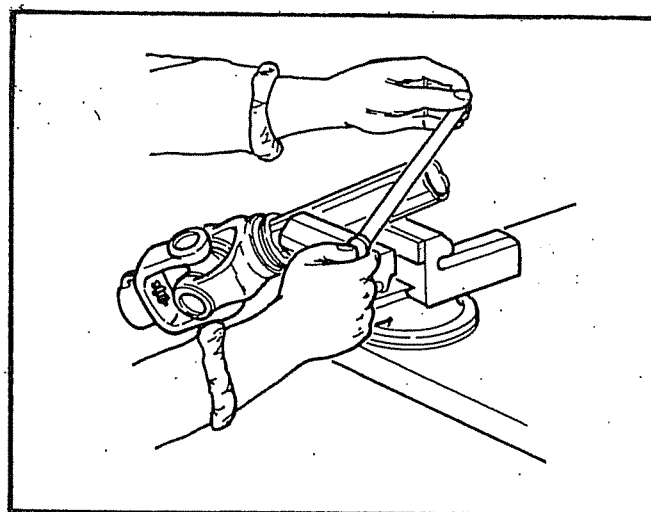

Cut the same amount off both guard halves as cut off the shafts.

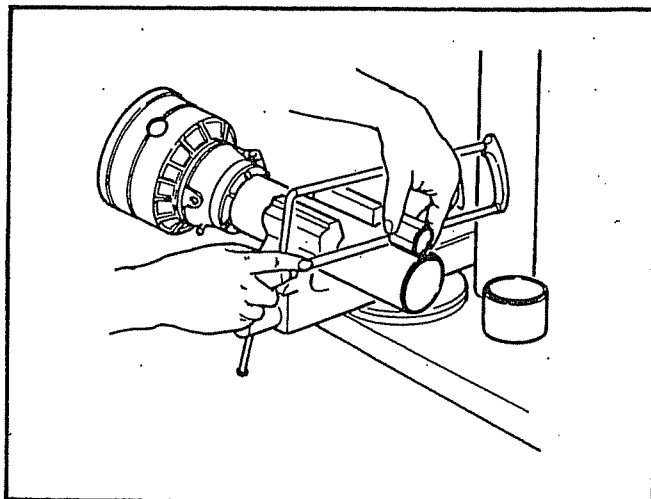

Slide the shafts into the guards. Refit the three screws, turn through 90° to secure and reassemble both shaft halves together



## HYDRAULIC SYSTEM

### Oil supply

Check the oil level in the reservoir daily.

No fixed time period can be quoted for oil changes as operating conditions and maintenance standards vary so widely. Burnt and scorched oil odours and the oil darkening and thickening are all signs of oxidation and indicate the oil should be changed.

Moisture which results from condensation can become entrapped in the oil and cannot be removed by filtration so that water contamination is progressive.

Contamination can be reduced by:-

- 1) Cleaning around the reservoir cap before removal, and keeping that area clean
- 11) Using clean containers when replenishing the system
- 111) Regular servicing of the filtration system.

### Filtration Maintenance

The machine is protected by a 125 micron suction strainer and a low pressure 10 micron full flow return line filter.

- 1) Suction strainer

The strainer is permanently fixed within the reservoir.

Should symptoms of pump cavitation or spongy intermittent operation occur the tank must be drained and flushed out with a suitable cleaning agent eg. clean diesel oil

- 11) Return Line Filter

The elements should be changed after the first 50 hours and thereafter at 500 hour intervals. It is important to note hours worked as if the filter becomes blocked an internal by-pass within the canister will operate and no symptoms of filter malfunction will occur to jog your memory.

## HYDRAULIC HOSES

The condition of all hoses should be carefully checked during routine service of the machine. Hoses that have been chafed or damaged on their outer casing should be securely wrapped with waterproof adhesive tape to stop the metal braid from rusting. Hoses that have suffered damage to the metal braid should be changed at the earliest opportunity.

### HOSE REPLACEMENT

- a. Replace one hose at a time to avoid the risk of wrong connections.
- b. When the hose is screwed to an additional fitting or union, use a second spanner on the union to avoid breaking both seals.
- c. Do not use jointing compound on the threads.
- d. Avoid twisting the hose. Adjust the hose line to ensure freedom from rubbing or trapping before tightening hose end connections.

Before changing hoses study the installation these are carefully calculated to prevent hose damage during operation. Always replace hoses in exactly the same manner. This is especially important for the flail hoses where they must be crossed, upper to lower, at the dipper and head pivots.

All Hydraulic Hoses (B.S.P.) now fitted to McConnel Power Arm Hedge/Grass Cutters have "Soft Seal" connections on both flail and ram circuit hoses.

Recommended torque settings for nut security are as follows:-

M 14	1/4" BSP	=	24 N.m	or	18 lbf ft
M 18	3/8" BSP	=	33 N.m	or	24 lbf ft
M 22	1/2" BSP	=	44 N.m	or	35 lbf ft
M 26	5/8" BSP	=	58 N.m	or	43 lbf ft
M 30	3/4" BSP	=	84 N.m	or	62 lbf ft
M 36	1" BSP	=	115 N.m	or	85 lbf ft

For hose unions (B.S.P.) fitted in conjunction with bonded seals the recommended torque settings are as follows:-

1/4" BSP	=	34 N.m	or	25 lbf ft
3/8" BSP	=	75 N.m	or	55 lbf ft
1/2" BSP	=	102 N.m	or	75 lbf ft
5/8" BSP	=	122 N.m	or	90 lbf ft
3/4" BSP	=	183 N.m	or	135 lbf ft
1" BSP	=	203 N.m	or	150 lbf ft

### \*SAFETY NOTE\*

Soft Seal hose connections are capable of holding pressure when the nut is only "finger tight". It is therefore recommended that when dismantling the hose is manually flexed, to relieve any residual pressure, with the retaining nut slackened prior to complete disassembly.

# HOSE CONNECTIONS

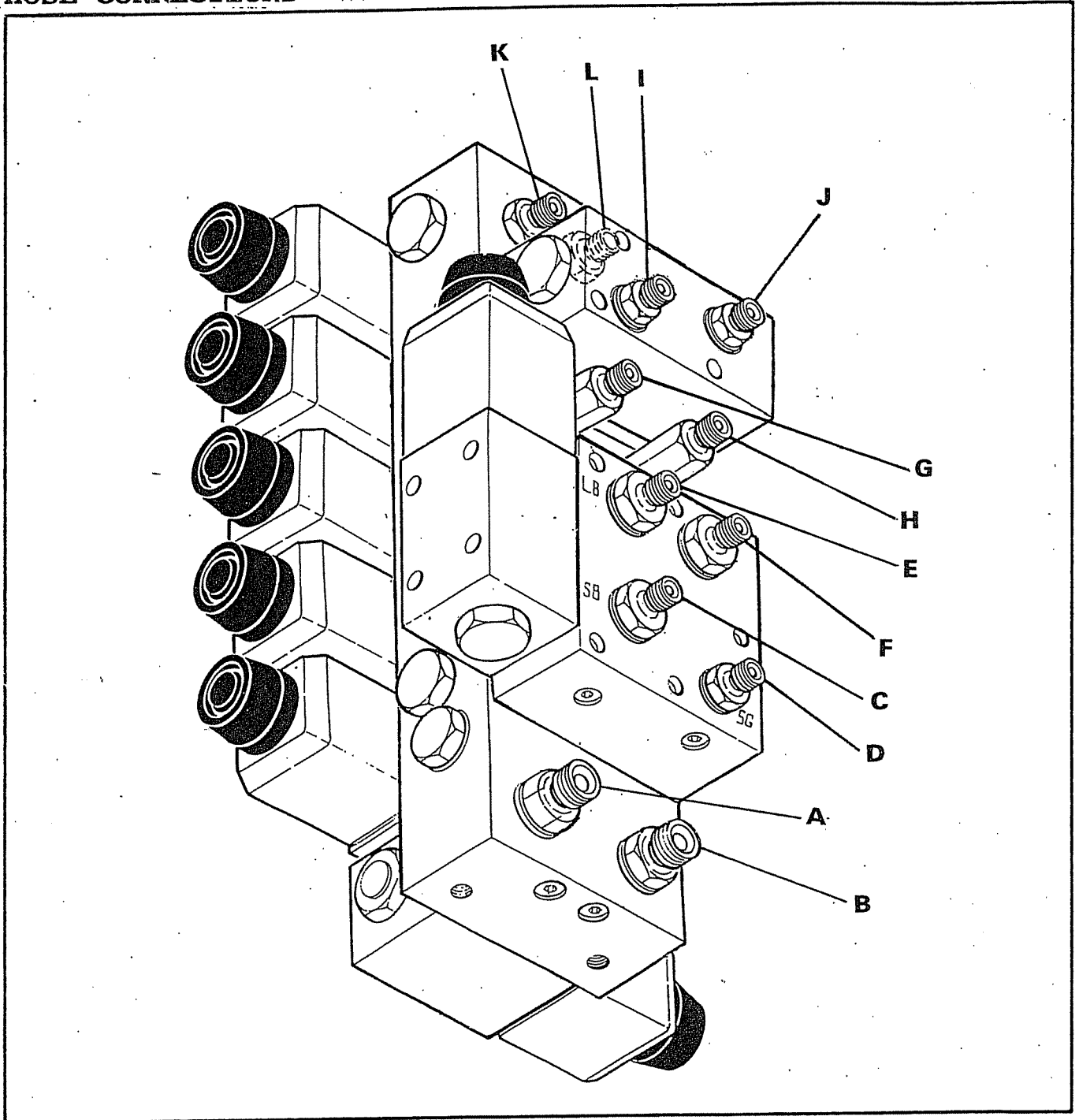

## MAIN VALVE -

- |  |  |
|--|--|
| A - Supply   | B - Return to Rotor control valve                      |
| C - Slew base  | D - Slew gland   |
| E - Lift base  | F - Lift gland   |
| G - Tele base (if fitted)<br>Midcut base (if fitted) | H - Tele gland (if fitted)<br>Midcut gland (if fitted) |
| I - Angle base                                       | J - Angle gland  |
| K - Reach base                                       | L - Reach gland  |

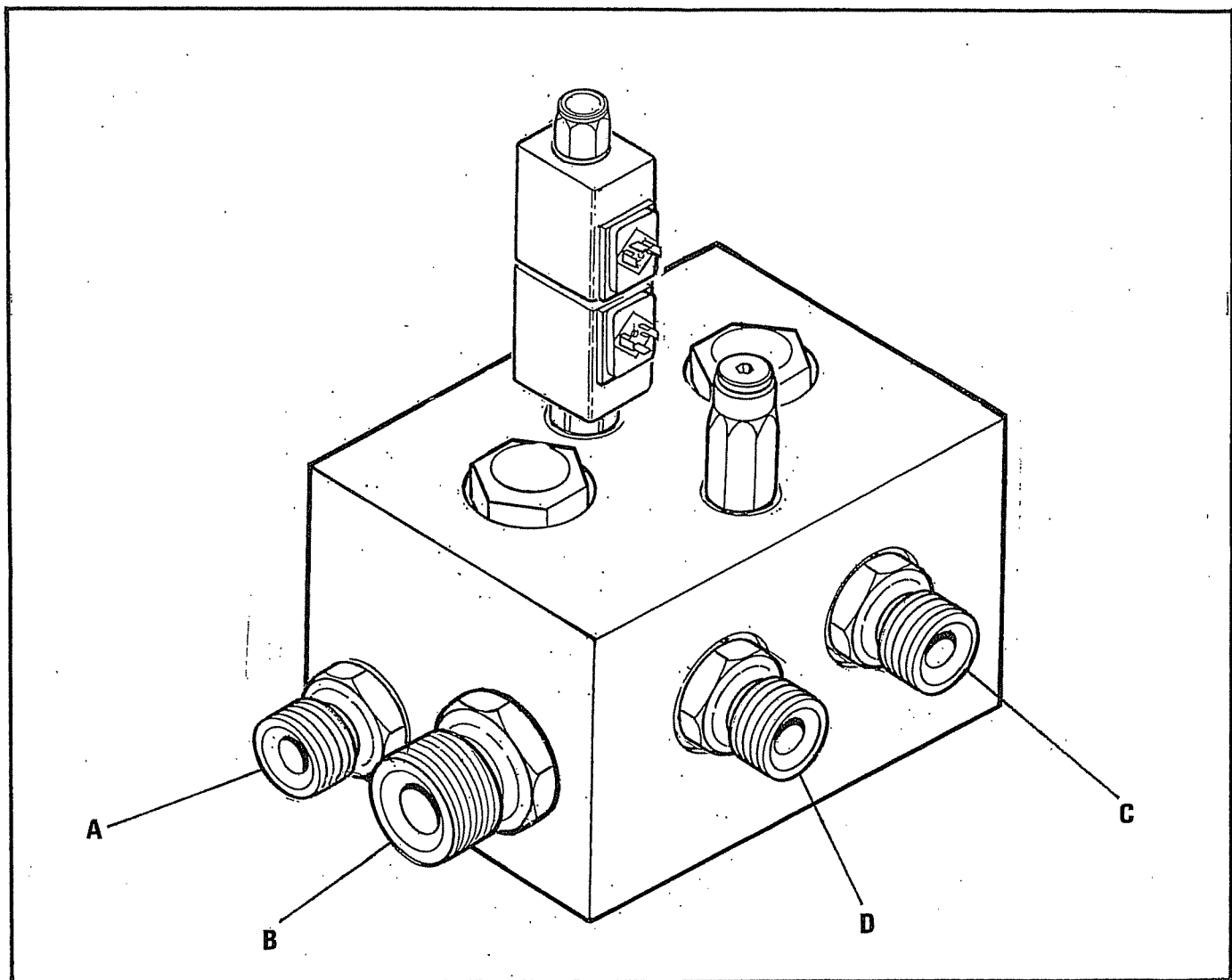

**ROTOR CONTROL VALVE. - Gear hydraulic machines only**

A - Supply from pump

B - Return to tank

C - Motor upper

D - Motor lower

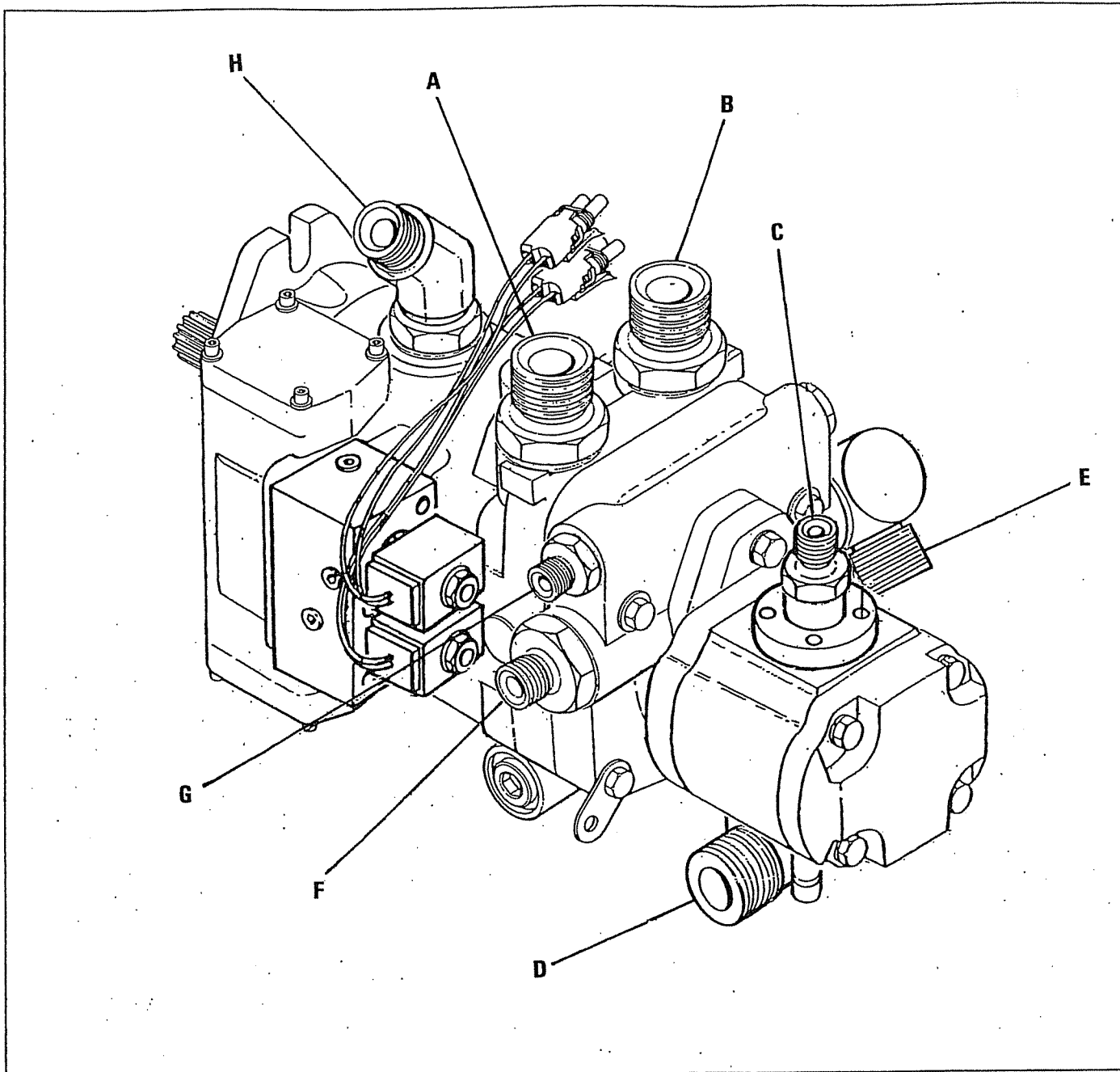

**PUMP -- Piston machines only**

- A - Motor upper
- B - Motor lower
- C - Supply to armhead valve
- D - Suction from tank
- E - Suction from tank
- F - Supply to charge filter
- G - Return from charge filter
- H - Return to tank

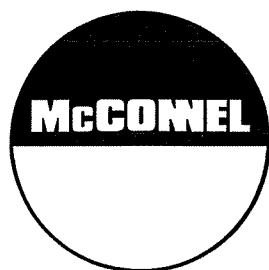

McConnel Limited, Temeside Works, Ludlow, Shropshire SY8 1JL. England.  
Telephone: 01584 873131. Facsimile: 01584 876463. [www.mcconnel.com](http://www.mcconnel.com)