

PA 500 PA 590

Operator Manual



McCONEL

IMPORTANT

VERIFICATION OF WARRANTY REGISTRATION

(Applies to UK Machines only)



UK DEALER WARRANTY INFORMATION & REGISTRATION VERIFICATION

It is imperative that the selling dealer registers this machine with McConnel Limited within 7 days of delivery to the end user – failure to do so may affect the validity of the machine warranty.

To register a machine go to the McConnel Limited web site at www.mcconnel.com, log on to 'DEALER INSIDE' and select the 'Machine Registration button' which can be found in the Service Section of the site. Confirm to the customer that the machine has been registered in the section below.

Should you experience any problems registering a machine in this manner please contact the McConnel Service Department on 01584 875848.

Registration Verification (UK Machines)

Dealer Name:
Dealer Address:
Customer Name:
Date of Warranty Registration:/...../..... Dealer Signature:

NOTE TO CUSTOMER / OWNER

Please ensure that the above section above has been completed and signed by the selling dealer to verify that your machine has been registered with McConnel Limited.

EC DECLARATION OF CONFORMITY

*Conforming to EEC Machinery Directive 98/37/EC**

We,

McCONNEL LIMITED,

Temeside Works, Ludlow, Shropshire SY8 1JL.

Declare under our sole responsibility that:

The product (*type*) ..Tractor Mounted Flail Mower / Cutter.....

.....

Product Code ..P500, P590.....

Serial No. & Date Type

Manufactured by the above company/*

.....

(* *insert business name and full address if not stated above*)

Complies with the required provisions of the Machinery Directive 98/37/EC, * previously Directive 89/392/EEC as amended by Directives 91/368/EEC, 93/44/EEC and 93/68/EEC.

The machinery directive is supported by;

- BS EN ISO 12100:2003 Safety of Machinery. This standard is made up of two parts; Part 1 Terminology, methodology, Part 2 Technical Specifications.
- BS EN 1050 Safety of machinery - Principles of risk assessment.
- and other national standards associated with its design and construction as listed in the Technical File.

The Machinery Directive is fully implemented into UK law by means of the Supply of Machinery (Safety) Regulations 1992 (SI 1992/3073) as amended by The Supply of Machinery (Safety) (Amendment) Regulations 1994 (SI 1994/2063).

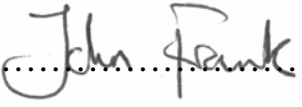
Signed 

on behalf of McCONNEL LIMITED

Responsible Person

Status: Chief Design Engineer

Date: 25th January 2005

LIST OF CONTENTS

GENERAL INFORMATION	Page 1
FEATURES	Page 3
SAFETY PRECAUTIONS	Page 5
FITTING	Page 9
Minimum tractor weight	Page 9
Minimum h.p. requirements	Page 9
Linkage	Page 9
P.T.O. shaft	Page 9
Linkage isolation	Page 9
Check chains	Page 9
Tractor relief valve	Page 9
Tractor hydraulic flow rates	Page 9
TRACTOR PREPARATION	Page 10
Fitting operator guard	Page 10
Wheel width	Page 10
Ballast weight	Page 10
Lift links	Page 10
Closed centre conversion kit	Page 11
INITIAL ATTACHMENT TO TRACTOR	Page 12
OIL REQUIREMENTS	Page 19
FITTING CONTROL IN CAB	Page 20
RUNNING UP PROCEDURE	Page 21
REMOVAL FROM TRACTOR	Page 22
STORAGE	Page 23
SUBSEQUENT FITTING	Page 23
OPERATION	Page 24
OPERATION GUARD	Page 24
PREPARATION	Page 24
TRACTOR CONTROLS	Page 24
MACHINE CONTROLS	Page 25
Cable controlled machines	Page 25
Electric controlled machines	Page 27
Switch function	Page 29
ROTOR CONTROL	Page 31
BREAKAWAY	Page 33
POWERED SLEW	Page 34
AHC	Page 35
WIRE TRAP	Page 35
REMOVING WIRE	Page 35
MOVING INTO THE TRANSPORT POSITION	Page 36
MOVING FROM TRANSPORT TO WORK	Page 39
ENGAGING DRIVE	Page 39
ROTOR OPERATING SPEED	Page 40
FORWARD SPEED	Page 40
HIGHWAY WORKING	Page 41
WORKING PRACTISES	Page 41
CUTTING PRECAUTIONS	Page 41
HIGH VOLTAGE CABLES	Page 42
OVERHEAD OBSTRUCTIONS	Page 42
CUTTING SEQUENCE	Page 43
WORKING ON ADVERSE SLOPES	Page 44

LIFT FLOAT KIT (optional extra)	Page 45
ANGLE FLOAT (optional extra electric machines only)	Page 46
MAINTENANCE	Page 47
LUBRICATION	Page 47
General	Page 47
P.T.O. shaft	Page 47
HYDRAULIC SYSTEM	Page 48
HYDRAULIC HOSES	Page 49
P.T.O. GEARBOX	Page 50
CABLES	Page 50
HOSE CONNECTIONS	Page 51

GENERAL INFORMATION

Read this manual before fitting or operating the machine. Whenever any doubt exists contact your dealer or the McConnel Service Department for assistance.

Use only McConnel spare parts on McConnel equipment and machines.

DEFINITIONS

The following definitions apply throughout this manual:

WARNING

An operating procedure, technique etc., which can result in personal injury or loss of life if not observed carefully.

CAUTION

An operating procedure, technique etc., which can result in the damage of either machine or equipment if not observed carefully.

NOTE

An operating procedure, technique etc., which is considered essential to emphasise.

Left and Right-Hand

This term is applicable to the machine when fitted to the tractor and viewed from the rear. This also applies to tractor references.

Record the serial number of your machine on this page and always quote this number when ordering spares. Whenever information concerning the machine is requested remember to also state the type of tractor to which it is fitted.	
MACHINE SERIAL NUMBER	INSTALLATION DATE
MODEL DETAILS	
DEALERS NAME	
DEALERS TELEPHONE NUMBER	

READ THE BOOK FIRST

It might save hours and pounds later !

When ordering spare parts always quote

- ***The Machine Type***
- ***The Machine Serial Number***
- ***The Part Number***

*Factory re-built service exchange units of
the major hydraulic components are
available from your Dealer*

NOISE

The equivalent daily personal noise exposure from this machine, measured at the operators' ear, is within the range 78 – 85 DB.

These figures apply to a normal distribution of use where the noise fluctuates between zero and maximum. The figures assume that the machine is fitted to a tractor with a quiet cab with the windows closed in a generally open environment. We recommend that the windows are kept closed.

With the cab rear window open the equivalent daily personal noise exposure will increase to a figure within the range 82 – 88 DB.

At equivalent daily noise exposure levels of between 85 and 90 DB, ear protection is recommended, it should be used if any window is left open.

FEATURES

PA500 - ALL MODELS

- Linkage mounted.
- Right or left hand cutting.
- Operator guard.
- Hydraulic breakaway.
- 95 deg powered slew.
- 200 litre hydraulic reservoir.
- Choice of 1.2 multicut/supercut 1.5m supercut flailheads.

PA500 Si

- Semi independent hydraulics - tractor power for arm movement. P.T.O pump for rotor.
- Rotor engagement by tractors P.T.O lever.
- 54 hp hydraulic system.
- Cable controls.
- Head angle float.

PA500 Ti

- Totally independent hydraulics powered by tandem P.T.O pump.
- Independent reversible rotor on/off valve.
- 54 hp hydraulic system.
- Cable controls.
- Head angle float.

PA500 E

- Totally independent hydraulics powered by tandem P.T.O pump.
- Independent reversible rotor on/off valve.
- Solenoid operated controls.
- Choice of multiswitch or joystick controls.
- 54 hp hydraulic system.

OPTIONAL EXTRAS

- Lift float - all models.
- Head angle float] E models.
- Auto Head Control]

PA590 - ALL MODELS

- Linkage mounted.
- Right or left hand cutting.
- Operator guard.
- Hydraulic breakaway.
- 95 deg powered slew.
- 200 litre hydraulic reservoir.
- 1.2 supercut flail head.
- 54 hp hydraulic system.

PA590 Si

- Semi independent hydraulics. Tractor power for arm movement. P.T.O pump for rotor.
- Rotor engagement by tractors P.T.O lever.
- Cable controls.
- Head angle float.

PA590 Ti

- Totally independent hydraulics powered by tandem P.T.O pump.
- Independent reversible rotor on/off valve.
- Cable controls.
- Head angle float.

PA590 E

- Totally independent hydraulics powered by tandem P.T.O pump.
- Independent reversible rotor on/off valve.
- Solenoid operated controls.
- Choice of multiswitch or joystick controls.

OPTIONAL EXTRAS

- Lift float - all models.
- Head angle float - E model.

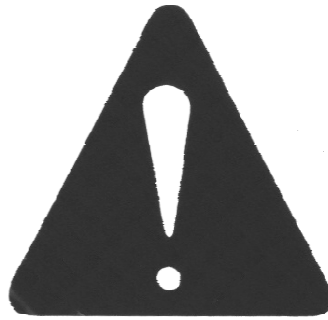

SAFETY INFORMATION



This machine has the potential to be extremely dangerous, in the wrong hands it can kill or maim. It is therefore imperative that the owner, and the operator of this machine, read the following section to ensure that they are both fully aware of the dangers that do, or may exist, and their responsibilities surrounding its use.

The operator of this machine is responsible not only for their own safety but equally for the safety of others who may come into the close proximity of the machine, as the owner you are responsible for both.

POTENTIAL SIGNIFICANT DANGERS ASSOCIATED WITH THE USE OF THIS MACHINE:

- ▲ *Being hit by debris thrown by rotating components.*
- ▲ *Being hit by machine parts ejected through damage during use.*
- ▲ *Being caught on a rotating power take-off (PTO) shaft.*
- ▲ *Being caught in other moving parts i.e.: belts, pulleys and cutting heads.*
- ▲ *Electrocution from Overhead Power Lines (by contact with or 'flashover' from).*
- ▲ *Being hit by cutting heads or machine arms as they move.*
- ▲ *Becoming trapped between tractor and machine when hitching or unhitching.*
- ▲ *Tractor overbalancing when machine arm is extended.*
- ▲ *Injection of high-pressure oil from hydraulic hoses or couplings.*
- ▲ *Machine overbalancing when freestanding (out of use).*
- ▲ *Road traffic accidents due to collision or debris on the road.*

BEFORE USING THIS MACHINE YOU MUST:

- ▲ *Ensure you read all sections of the operator handbook.*
- ▲ *Ensure the operator is, or has been, properly trained to use the machine.*
- ▲ *Ensure the operator has been issued with and reads the operator handbook.*
- ▲ *Ensure the operator understands and follows the instructions in operator handbook.*
- ▲ *Ensure the tractor front, rear and side(s) are fitted with metal mesh or polycarbonate guards of suitable size and strength to protect the operator against thrown debris or parts.*
- ▲ *Ensure tractor guards are fitted correctly, are undamaged and kept properly maintained.*
- ▲ *Ensure that all machine guards are in position, are undamaged, and are kept maintained in accordance with the manufacturer's recommendations.*
- ▲ *Ensure flails and their fixings are of a type recommended by the manufacturer, are securely attached and that none are missing or damaged.*
- ▲ *Ensure hydraulic pipes are carefully and correctly routed to avoid damage by chaffing, stretching or pinching and that they are held in place with the correct fittings.*
- ▲ *Always follow the manufacturer's instructions for attachment and removal of the machine from the tractor.*
- ▲ *Check that the machine fittings and couplings are in good condition.*
- ▲ *Ensure the tractor meets the minimum weight recommendations of the machine's manufacturer and that ballast is used as necessary.*
- ▲ *Always inspect the work area thoroughly before starting to note obstacles and remove wire, bottles, cans and other debris.*
- ▲ *Use clear suitably sized warning signs to alert others to the nature of the machine working within that area. Signs should be placed at both ends of the work site. (It is recommended that signs used are of a size and type specified by the Department of Transport and positioned in accordance with their, and the Local Highways Authority, guidelines).*
- ▲ *Ensure the operator is protected from noise. Ear defenders should be worn and tractor cab doors and windows must be kept closed. Machine controls should be routed through proprietary openings in the cab to enable all windows to be shut fully.*
- ▲ *Always work at a safe speed taking account of the conditions i.e.: terrain, highway proximity and obstacles around and above the machine. Extra special attention should be applied to Overhead Power Lines. Some of our machines are capable of reach in excess of 8 metres (26 feet) this means they have the potential to well exceed, by possibly 3 metres (9' 9"), the lowest legal minimum height of 5.2 metres from the ground for 11,000 and 33,000 volt power lines. It cannot be stressed enough the dangers that surround this capability, it is therefore vital that the operator is fully aware of the maximum height and reach of the machine, and that they are fully conversant with all aspects regarding the safe minimum distances that apply when working with machines in close proximity to Power Lines. (Further information on this subject can be obtained from the Health & Safety Executive or your Local Power Company).*

- ▲ *Always disengage the machine, kill the tractor engine, remove and pocket the key before dismounting for any reason.*
- ▲ *Always clear up all debris left at the work area, it may cause hazard to others.*
- ▲ *Always ensure when you remove your machine from the tractor that it is left in a safe and stable position using the stands and props provided and secured if necessary.*

WHEN NOT TO USE THIS MACHINE:

- ▲ *Never attempt to use this machine if you have not been trained to do so.*
- ▲ *Never use a machine until you have read and understood the operator handbook, are familiar with it, and practiced the controls.*
- ▲ *Never use a machine that is poorly maintained.*
- ▲ *Never use a machine if guards are missing or damaged.*
- ▲ *Never use a machine on which the hydraulic system shows signs of wear or damage.*
- ▲ *Never fit, or use, a machine on a tractor that does not meet the manufacturer's minimum specification level.*
- ▲ *Never use a machine fitted to a tractor that does not have suitable front, rear and side(s) cab guarding made of metal mesh or polycarbonate.*
- ▲ *Never use the machine if the tractor cab guarding is damaged, deteriorating or badly fitted.*
- ▲ *Never turn a machine cutting head to an angle that causes debris to be ejected towards the cab.*
- ▲ *Never start or continue to work a machine if people are nearby or approaching - Stop and wait until they are at a safe distance before continuing. WARNING: Some Cutting Heads may continue to 'freewheel' for up to 40 seconds after being stopped.*
- ▲ *Never attempt to use a machine on materials in excess of its capability.*
- ▲ *Never use a machine to perform a task it has not been designed to do.*
- ▲ *Never operate the tractor or machine controls from any position other than from the driving seat, especially whilst hitching or unhitching the machine.*
- ▲ *Never carry out maintenance of a machine or a tractor whilst the engine is running – the engine should be switched off, the key removed and pocketed.*
- ▲ *Never leave a machine unattended in a raised position – it should be lowered to the ground in a safe position on a level firm site.*
- ▲ *Never leave a tractor with the key in or the engine running.*
- ▲ *Never carry out maintenance on any part or component of a machine that is raised unless that part or component has been properly substantially braced or supported.*
- ▲ *Never attempt to detect a hydraulic leak with your hand – use a piece of cardboard.*
- ▲ *Never allow children near to, or play on, a tractor or machine under any circumstances.*

ADDITIONAL SAFETY ADVICE

Training

Operators need to be competent and fully capable of operating this machine in a safe and efficient way prior to attempting to use it in any public place. We advise therefore that the prospective operator make use of relevant training courses available such as those run by the Agricultural Training Board, Agricultural Colleges, Dealers and McConnel.

Working in Public Places

When working in public places such as roadsides, consideration should be paid to others in the vicinity. Stop the machine immediately when pedestrians, cyclists and horse riders etc. pass. Restart only when they are at a distance that causes no risk to their safety.

Warning Signs

It is advisable that any working area be covered by suitable warning signs and statutory in public places. Signs should be highly visible and well placed in order to give clear advanced warning of the hazard. Contact the Department of Transport or your Local Highways Authority to obtain detailed information on this subject. The latter should be contacted prior to working on the public highway advising them of the time and location of the intended work asking what is required by way of signs and procedure. – ‘*Non-authorised placement of road signs may create offences under the Highways Act*’.

Suggested Warning Signs Required

“Road works ahead” warning sign with a supplementary **“Hedge cutting”** plate. **“For 1 mile”** or appropriate shorter distance may be added to the plate.

“Road narrows” warning sign with supplementary **“Single file traffic”** plate.

White on blue **“Keep right”** (*) arrow sign on rear of machine.

* Note – this applies to UK Market machines where traffic passes to the right of a machine working in the same direction as the traffic flow. The direction, use and colour of the arrow sign will depend on the country of use and the Local Highway Authorities regulations in the locality.

Use of Warning Signs

- ▲ On two-way roads one set of signs is needed facing traffic in each direction.
- ▲ Work should be within 1 mile of the signs.
- ▲ Work only when visibility is good and at times of low risk e.g.: NOT during ‘rush-hour’.
- ▲ Vehicles should have an amber-flashing beacon.
- ▲ Ideally, vehicles should be conspicuously coloured.
- ▲ Debris should be removed from the road and path as soon as practicable, and at regular intervals, wearing high visibility clothing and before removing the hazard warning signs.
- ▲ Collect all road signs promptly when the job is completed.

Although the information given here covers a wide range of safety subjects, it is impossible to predict every eventuality that can occur under differing circumstances whilst operating this machine. No advice given here can replace ‘good common sense’ and ‘total awareness’ at all times, but will go a long way towards the safe use of your McConnel machine.

FITTING

TRACTOR REQUIREMENTS

Minimum tractor weights including ballast weight if necessary

All models - 3250 kg

Min Hp requirements

All models - 60 Hp

Linkage

Category II

P.T.O. shaft

Tractor must be equipped with a live drive P.T.O to enable forward motion to be stopped while the flail head continues to operate.

Linkage isolation

A linkage isolation facility is necessary for Si models only.

Check chains/stabilizers

Check chains or stabiliser bars must be fitted and tightened.

Tractor relief valve

For Si models only tractor relief valve must be set above 2000 psi (140 bar)

Tractor hydraulic flow rate

Hydraulic flow rates are not crucial for Si models

TRACTOR PREPARATION

Fitting Tractor Guard: Use tractor with safety glass windows if possible and fit Operator guard (*part no. 73 13 324*) using the hooks provided. Shape mesh to cover all vulnerable areas. Remember the driver must be looking through mesh and/or polycarbonate glazing when viewing the flail head in any working position - unless the tractor/cab manufacturer can demonstrate that the penetration resistance is equivalent to, or higher than, that provided by mesh/polycarbonate glazing. If the tractor has a roll bar only, a frame must be made to carry both mesh and polycarbonate glazing.

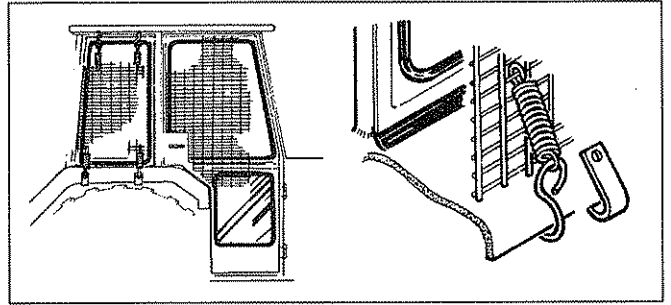

Wheel Width: Set wheel widths as wide as possible.

Lift Links: Adjust lift links until they are equal length.

Tractor Ballast: It is imperative when attaching 'third-party' equipment to a tractor that the maximum possible stability of the machine and tractor combination is achieved – this can be accomplished by the utilisation of 'ballast' in order to counter-balance the additional equipment added.

Front weights may be required to place 15% of total outfit weight on the front axle for stable transport on the road and to reduce 'crabbing' due to the drag of the cutting unit when working on the ground.

Rear weights may be required to maintain a reasonable amount of rear axle load on the opposite wheel from the arms when in work; for normal off-ground work i.e. hedge cutting this should be 20% of rear axle weight or more for adequate control, and for ground work i.e. verge mowing with experienced operators, this can be reduced to 10%.

All factors must be addressed in order to match the type and nature of the equipment added to the circumstances under which it will be used – in the instance of Power Arm Hedgecutters it must be remembered that the machines centre of gravity during work will be constantly moving and will differ from that during transport mode, therefore balance becomes critical.

Factors that effect stability:

- *Centre of gravity of the tractor/machine combination.*
- *Geometric conditions, e.g. position of the cutting head and ballast.*
- *Weight, track width and wheelbase of the tractor.*
- *Acceleration, braking, turning and the relative position of the cutting head during these operations.*
- *Ground conditions, e.g. slope, grip, load capability of the soil/surface.*
- *Rigidity of implement mounting.*

Suggestions to increase stability:

- *Increasing rear wheel track; a tractor with a wider wheel track is more stable.*
- *Ballasting the wheel; it is preferable to use external weights but liquid can be added to around 75% of the tyre volume – water with anti-freeze or the heavier Calcium Chloride alternative can be used.*
- *Addition of weights – care should be taken in selecting the location of the weights to ensure they are added to a position that offers the greatest advantage.*
- *Front axle locking; a ram can be used to 'lock' the front axle in work only – locking the axle moves the 'balance line' and can be used to transfer weight to the front axle from the rear (check with tractor manufacturer).*

The advice above is offered as a guide for stability only and is not a guide to tractor strength - it is therefore recommended that you consult your tractor manufacturer or local dealer to obtain specific advise on this subject, additionally advice should be sought from a tyre specialist with regard to tyre pressures and ratings suitable for the type and nature of the machine you intend to fit.

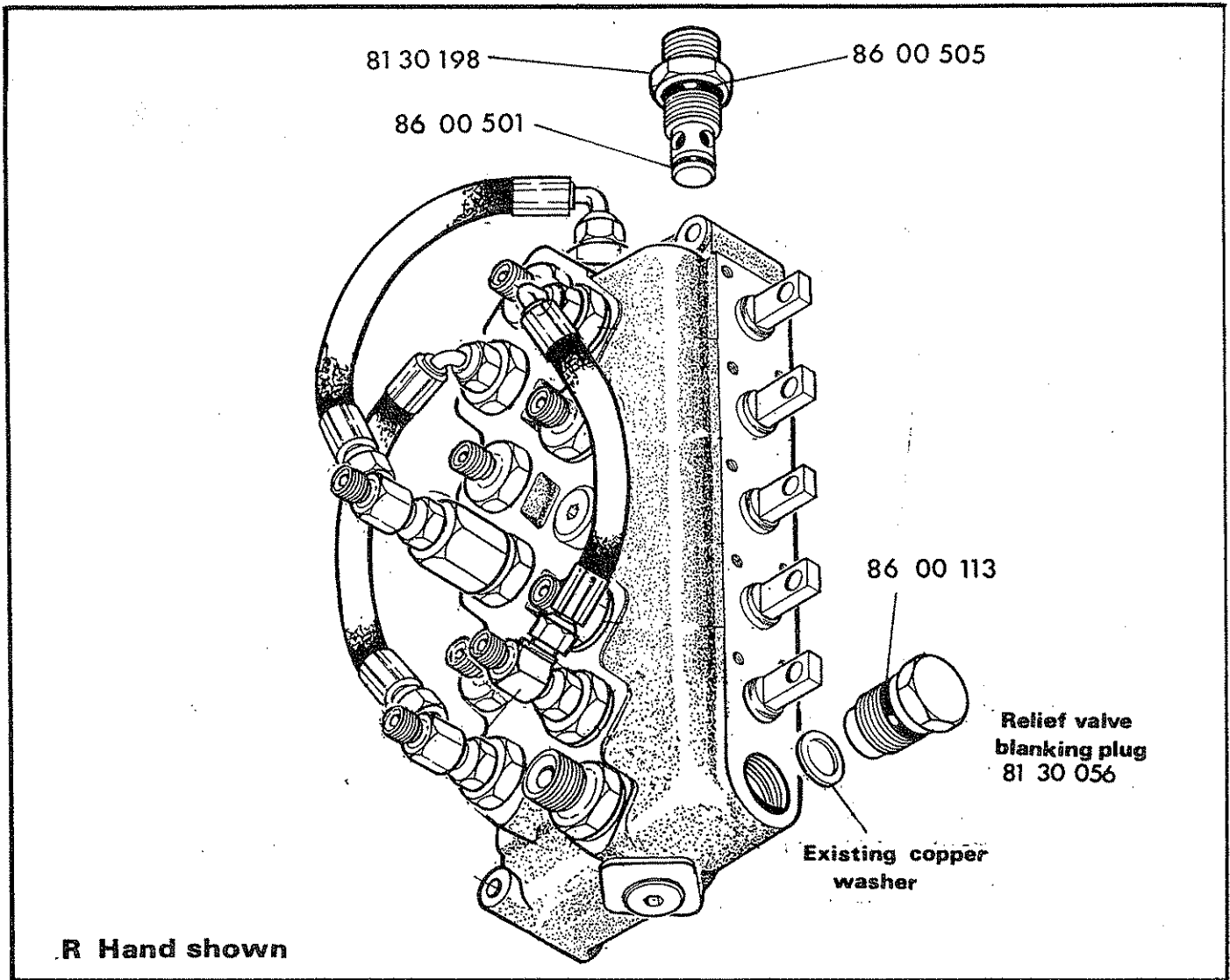

CLOSED CENTRE CONVERSION KIT for S.i. models only

A control valve conversion kit consists of a relief valve blanking plug which should be installed in place of the existing relief valve and a pressure gallery blanking adaptor which is installed in place of the standard adaptor at the valve outlet end next to the lift loop hose connection.

Take care when extracting the relief valve not to damage the copper sealing washer as it is re-used.

INITIAL ATTACHMENT TO TRACTOR

1. Choose a firm level site.
2. Cut banding straps and remove transport strap, loose items and stabiliser.

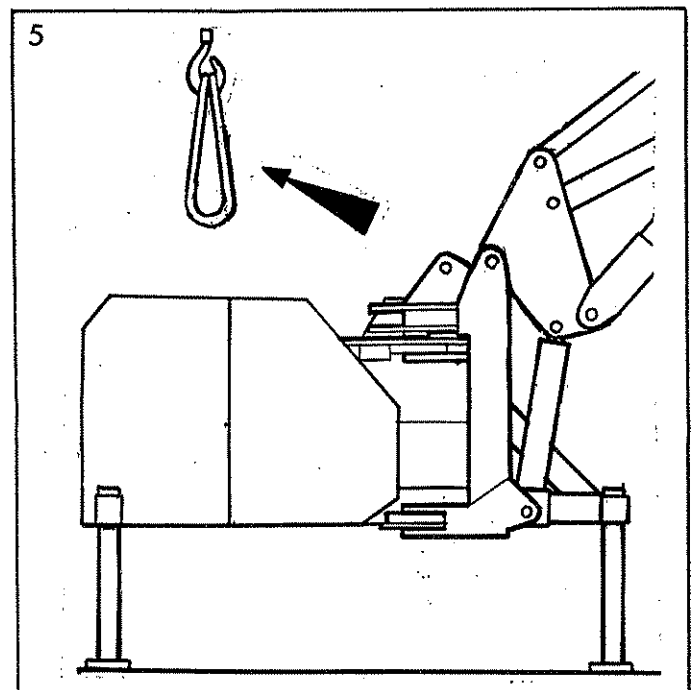
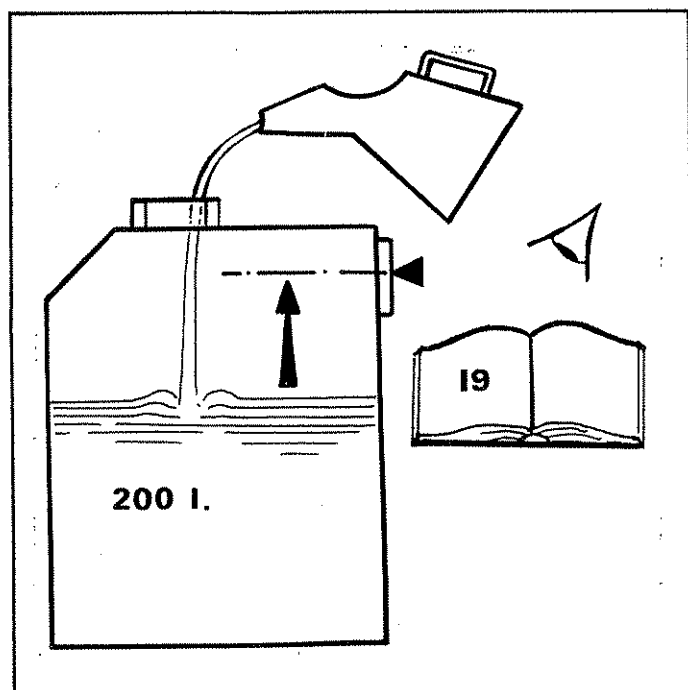
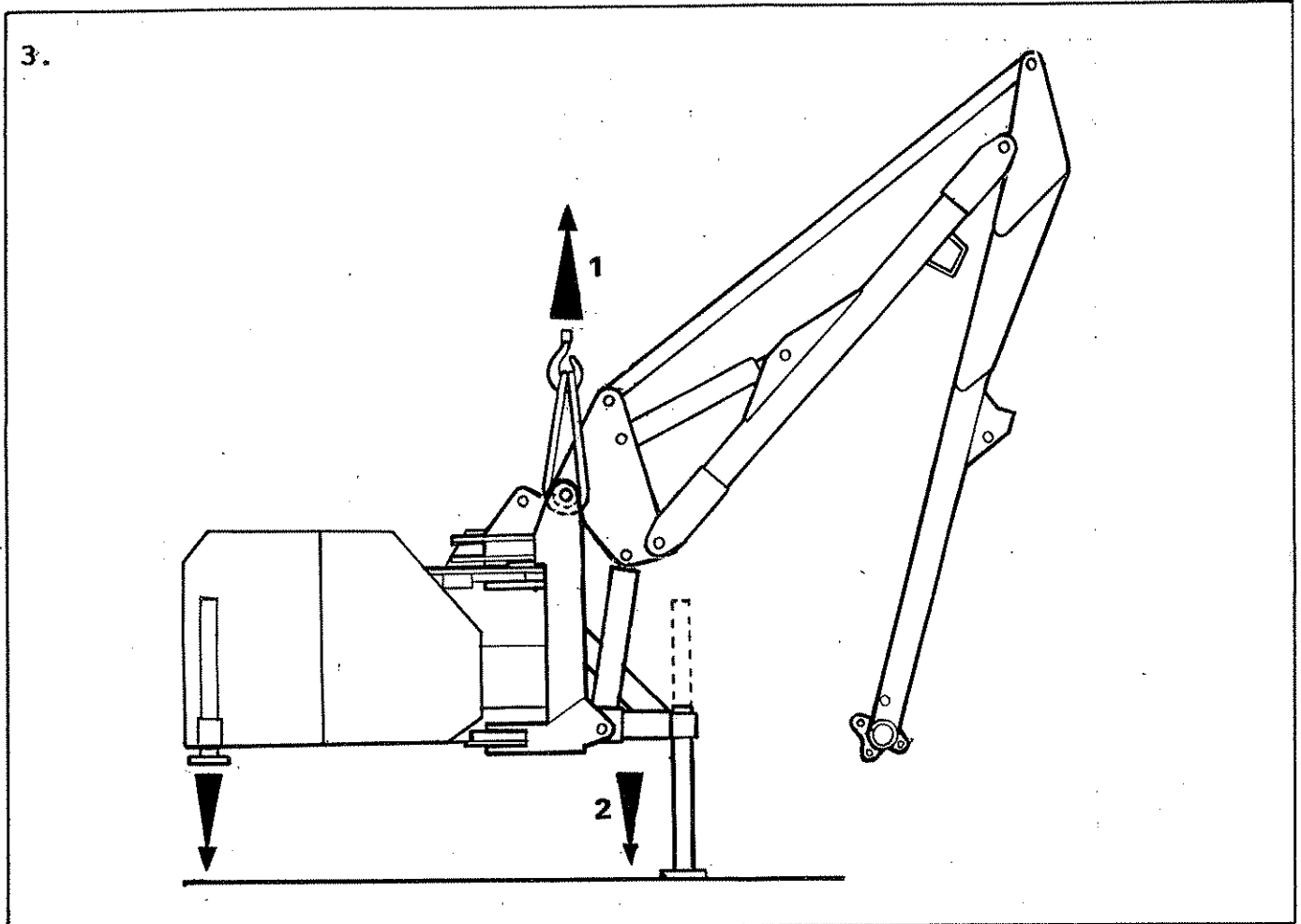

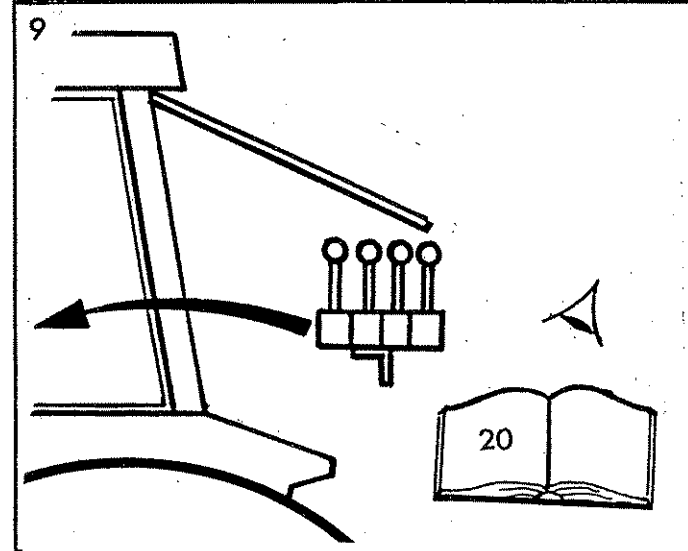
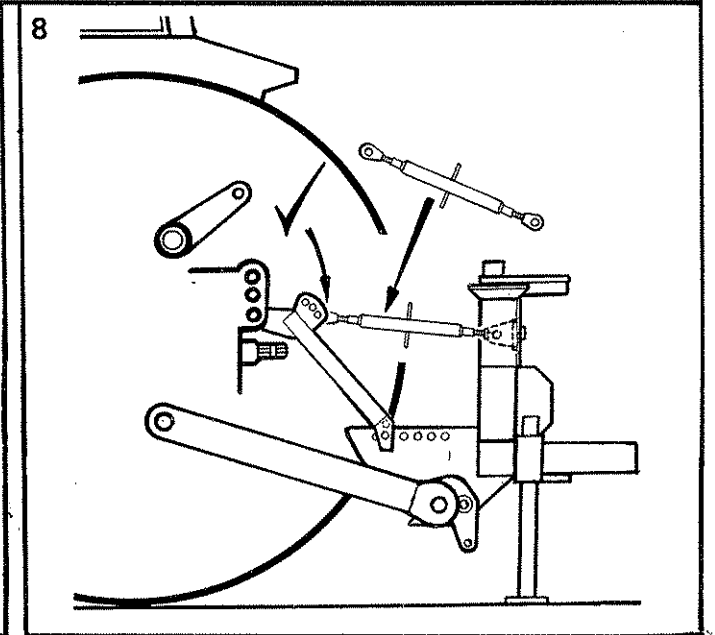
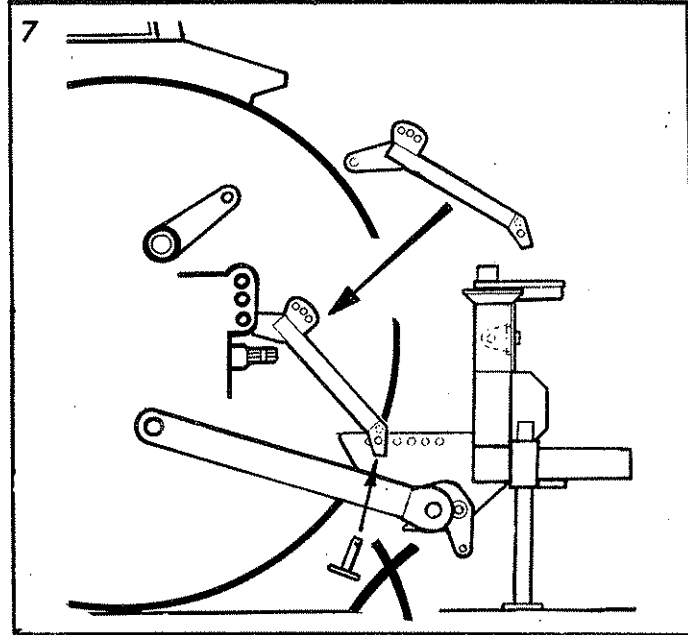
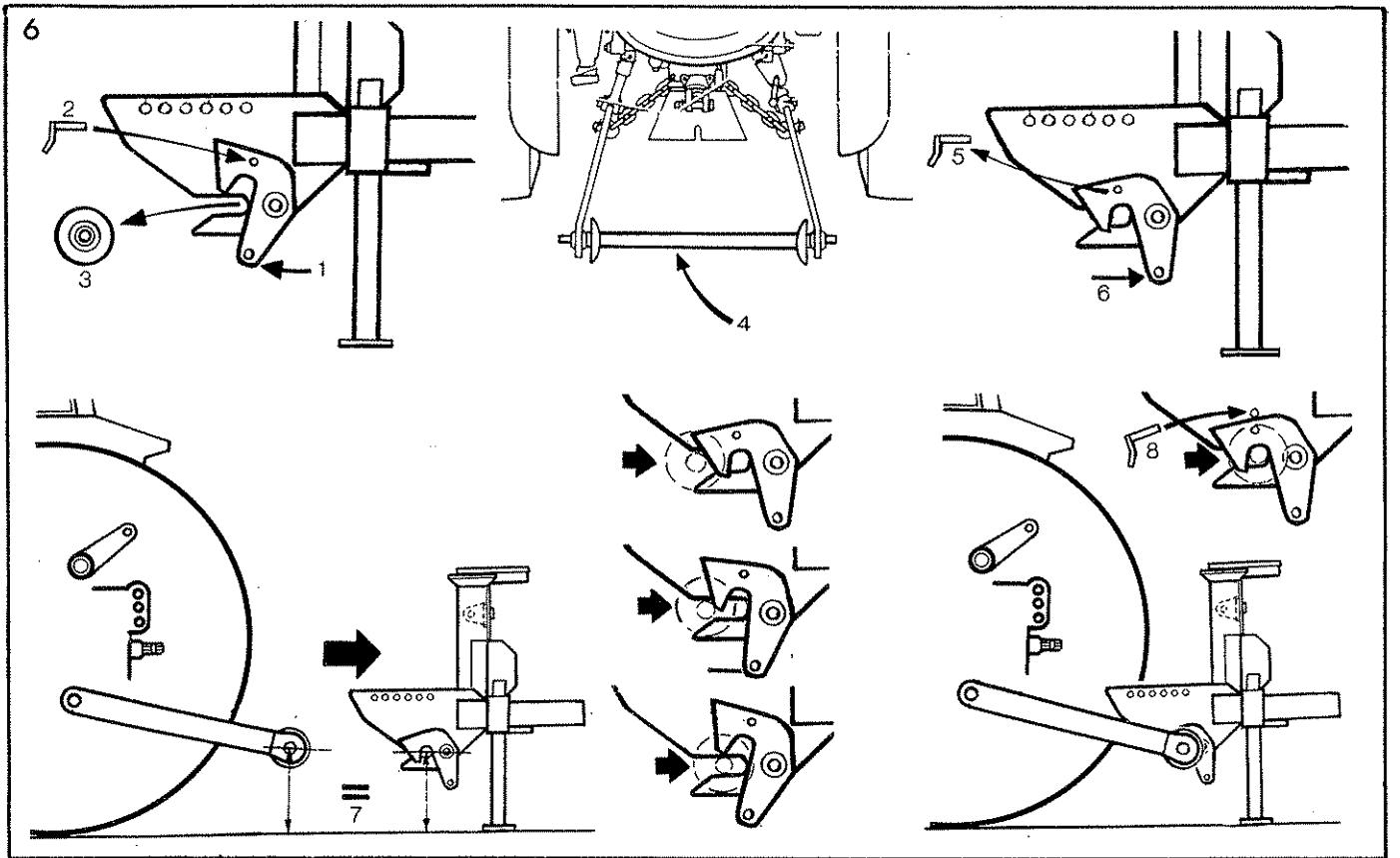

10

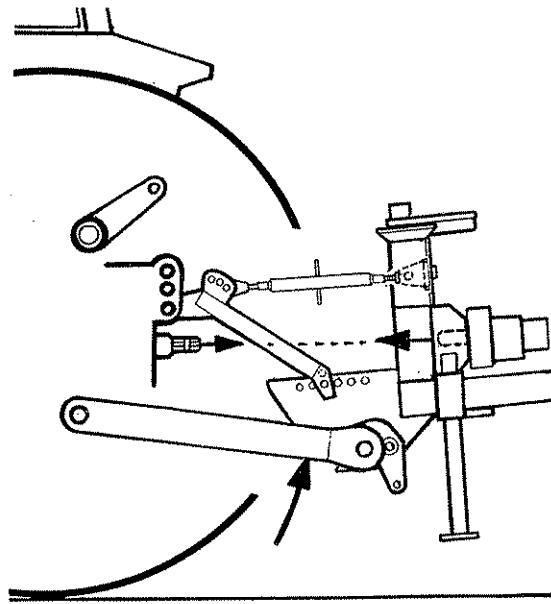

WARNING

The quadrant lever or machine controls must be operated from the tractor seat. During this operation ensure no one is standing on or amongst the linkage arm or bars.

Note:

As lift occurs be aware the machinery may tilt slightly.

11

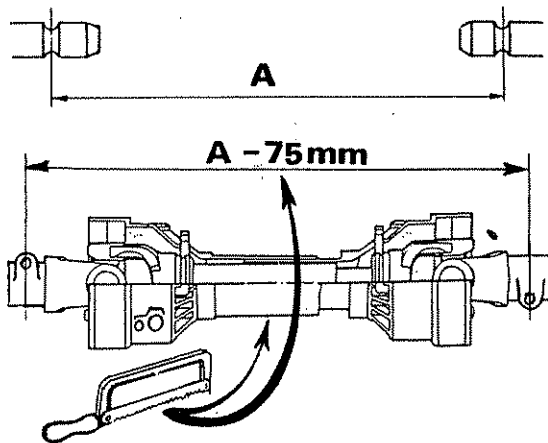

Measure 'A'.
Cut PTO shaft equal amounts of both halves to measure. A - 75mm when fully closed.

12

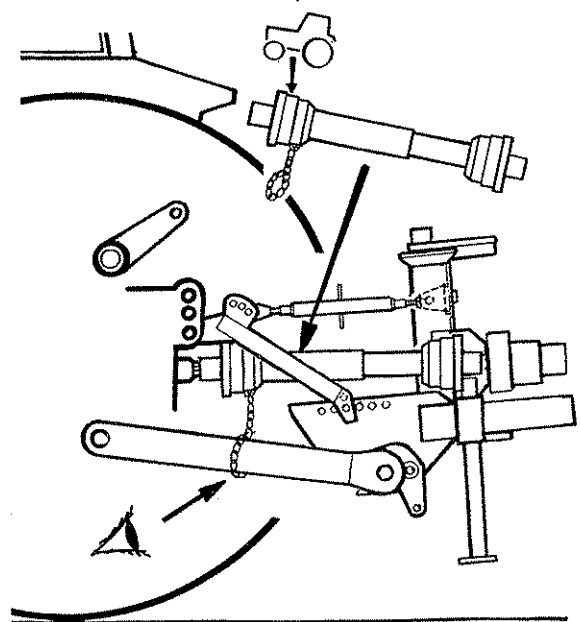

13. On semi independent machines only connect up the supply and return hoses.

Supply - from tractors auxiliary service
 Return - to tractors transmission casing - see tractor handbook
 Select tractors external services.

On totally independent machines only check the rotor control lever is in the "OFF" position and engage the P.T.O.

- 14 Ensure the lift ram tap is fully open.

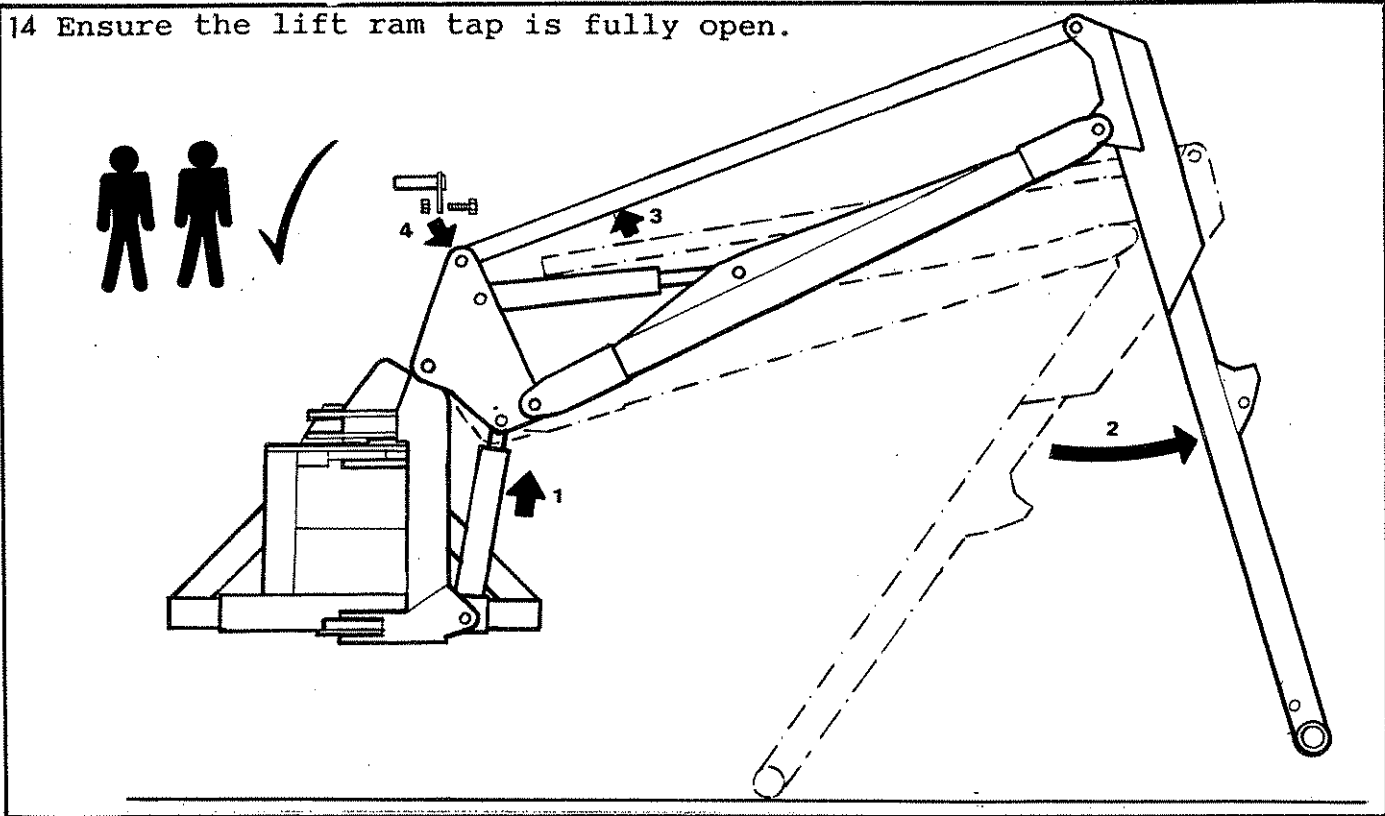

- 15 Operate the controls to slew the arms towards the rear only until the frame is horizontal.

16

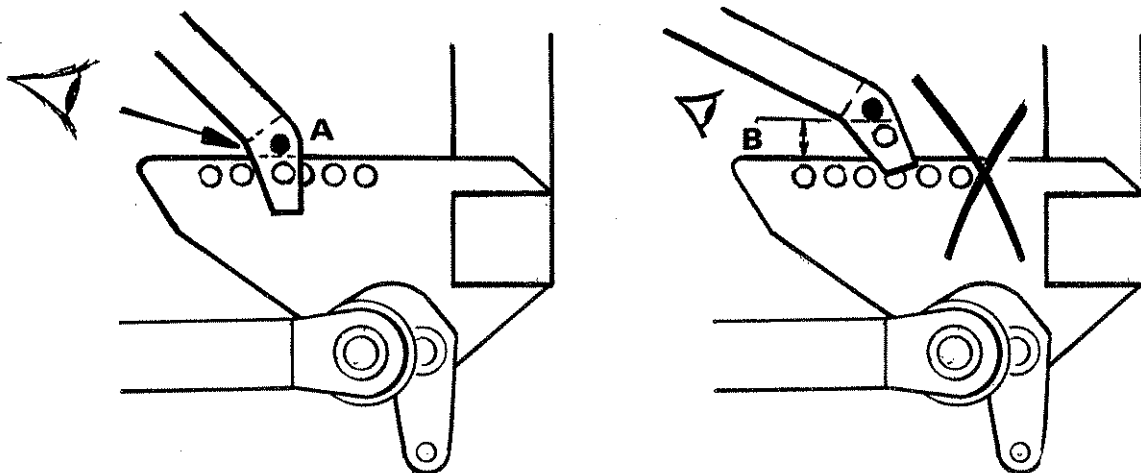

- B** Check the welded in pins between the stabiliser jaws are in contact with the mounting rail. If not the machine must be lowered to the ground and the next higher hole on the stabiliser quadrant selected, the machine raised and contact checked. Repeat again in the third hole if necessary. On subsequent fitting to the same tractor the hole selected is always used.

17

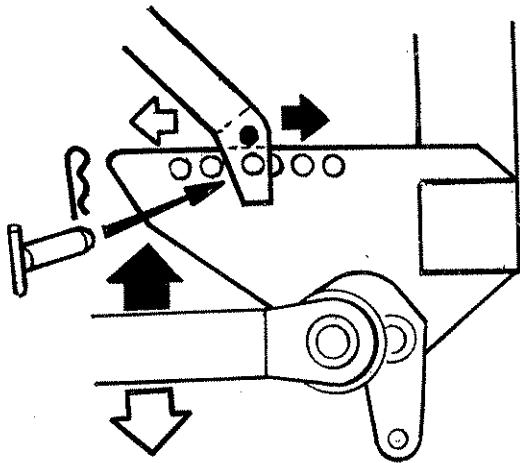

Fine adjust 'A'.
Use the mounting hole that allows the PTO and gearbox stub shaft to as nearly as possible in alignment.

18

Lower tractor linkage control so that machines weight is taken by the yoke and :-

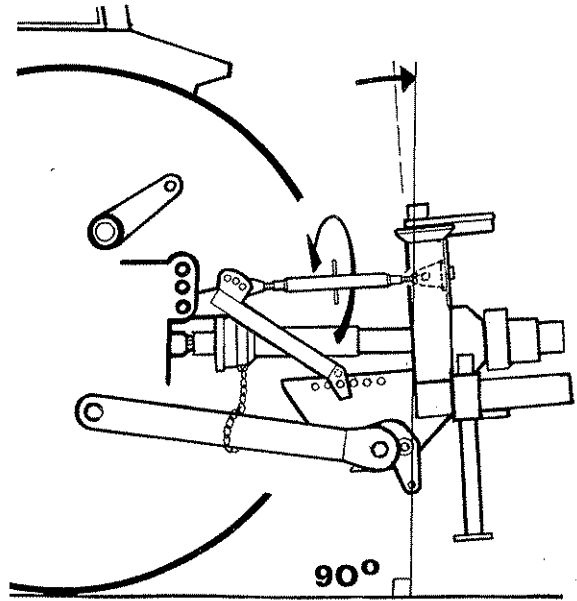

19

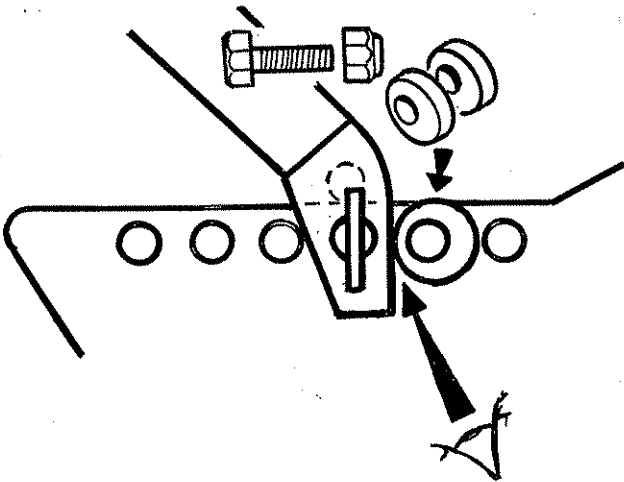

Fit eccentric stops.
These remain in position until tractor is changed.

20

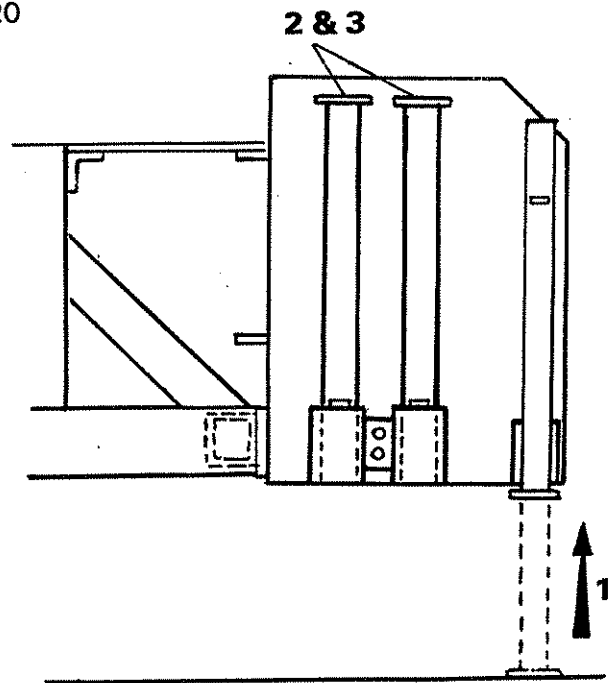

21

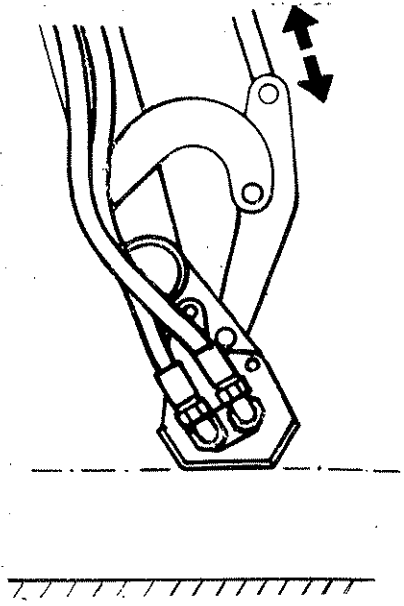

22

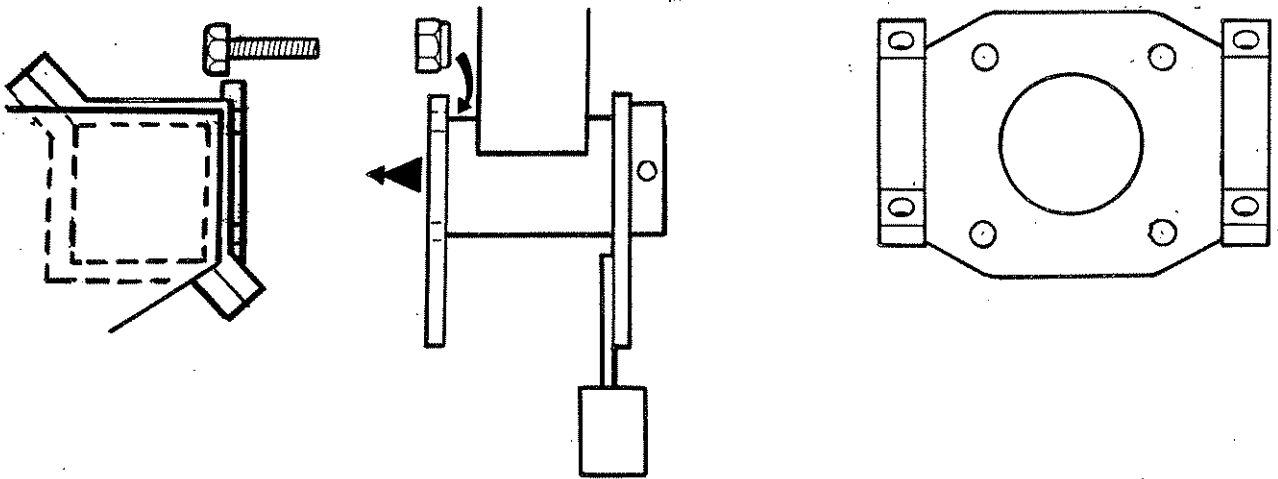

23 Connect hoses.

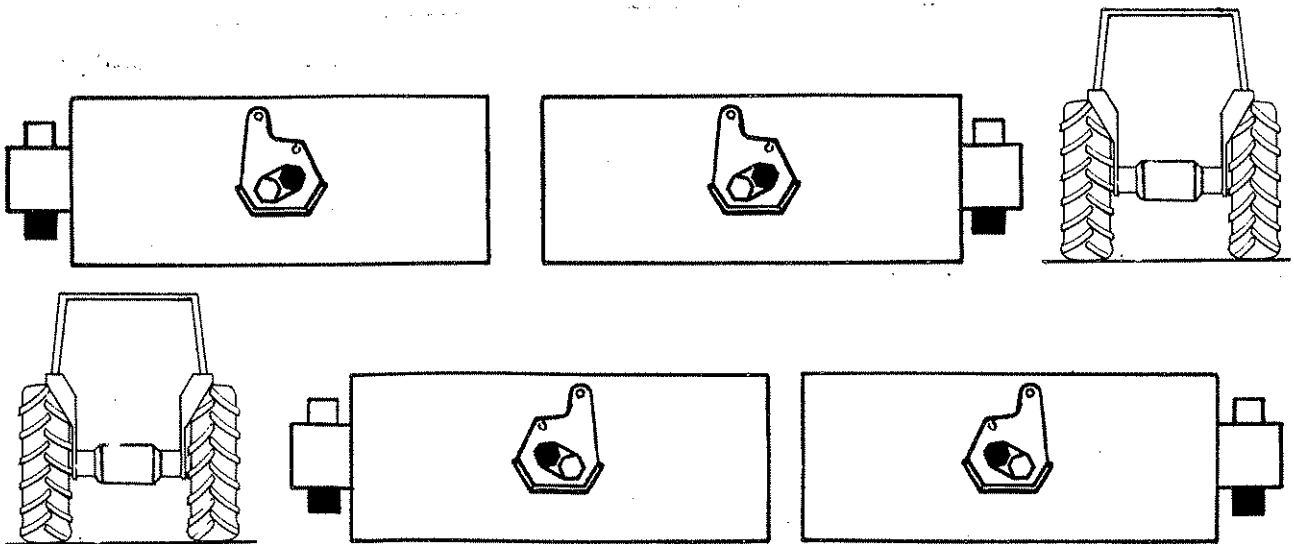

- 24 With the arms at half reach and with the flail head clear of the ground carry out final adjustment of the lift arm levelling box to bring the main frame horizontal.
- 25 Tighten check chains/stabiliser bars.
- 26 Carefully operate the machine through its full range of movements whilst checking that hoses are not strained, pinched, chafed or kinked and that all movements are functioning correctly.
- 27 Fold machine into the transport position (see page 36). The machine is now ready to transport to the worksite.

OIL REQUIREMENTS

Tank

Fill the reservoir to approximately 2" below the top of the tank.
The capacity is approximately 200 litres (44 imp galls)

Do not overfill.

Supplier	Cold or temperate climate	Hot climate
Castrol	Agricastrol hydraulic oil Hy-spin AWS 46	Hy-spin AWS68
Shell	Tellus 46	Tellus 68
Mobil	D.T.E. 25	D.T.E.26
Esso	Nuto 'H' or 'A' 46	Nuto 'H' or 'A' 68
Texaco	Rando HD 46	Rando D 68
Gulf	Hydrasil 46	Hydrasil 68
B.P.	Energol HLP 46	Energol HLP 68
Dalton	Silkolene Dove 46 or Derwent 46	Silkolene Dove 68 or Derwent 68
Elf	Hydrelf 46	Hydrelf 68

FITTING CONTROL UNIT IN CAB

Electric controlled models only

A mounting pillar is supplied to which the control unit is bolted. The pillar is bolted to the tractor ensuring that no structural member of the cab or roll bar is drilled and it can be bent or twisted to achieve a comfortable working position.

The supply cable should be connected directly to the tractors battery or to any 30 amp electrical output provided by the tractor manufacturer. Avoid using cigarette lighter type connections as these may prove to be sporadic and unreliable for control applications.

The control is 12 volt D.C. operated; the brown lead is Positive and the blue is Negative.

Cable controlled models

The control unit is bolted to a mounting bracket

This bracket may be bolted to the mudwing or cab cladding in a convenient location ensuring that no structural member of the cab or roll bar is drilled.

In deciding the final position of the control box remember not to exceed the minimum acceptable bend radii of 8" for the cables.

The control lever for the cable operated rotor control valve is mounted in a similar fashion adopting the same precautions pertaining to drilling and cable runs.

RUNNING UP PROCEDURE

Ti models only

Ensure that the rotor control valve is in "STOP" position, start tractor, engage P.T.O. allow the oil to circulate through the return line filter for about 5 minutes without operation of the armhead control lever.

Operate the armhead levers through their complete range ensuring that all movements are functioning correctly.

Place the flail head at a safe attitude and move the rotor control to "START" position. After initial fluctuation the rotor should settle to a steady speed. Increase P.T.O. speed to approximately 360 rpm. and run for a further five minutes before disengaging and stopping tractor.

Check the hose runs and observe that they are free from any pinching, chafing straining or kinks. Re-check the oil level in the tank and top up as necessary.

Si models only

Ensure P.T.O. lever is in neutral position, and isolate tractor hydraulic linkage. Start tractor and select external service supply. Allow the tractor to run for several minutes before attempting to operate any of the machine control levers.

On operating move the levers through their complete range ensuring that all movements are functioning correctly.

Check the tractor rear axle oil level and top up if necessary.

Place the flail head at a safe attitude and bring tractor engine revolutions to 1000 rpm. Engage P.T.O. and allow the rotor to run for several minutes. Do not leave the tractor cab or allow anyone to approach the flail head at this time.

Caution

Do not allow the pump to continue working if the rotor does not turn-Overheating and serious damage to the pump can be caused in a very short time.

After running up the machine increase P.T.O speed to approximately 360 rpm. and run for a further five minutes to allow the oil to circulate through the return line filter before disengaging the P.T.O. and stopping tractor.

Check the hose runs and observe that they are free from any pinching, chafing, straining or kinks. Re-check the oil level in the tank and top up as necessary.

REMOVAL FROM TRACTOR

DANGER

READ CAREFULLY BEFORE COMMENCING TO REMOVE THE MACHINE FROM THE TRACTOR.

THE ORDER OF THE FOLLOWING STEPS MUST BE FOLLOWED EXACTLY

DISCONNECTING THE TOP LINK MUST BE THE LAST OPERATION PRIOR TO DRIVING THE TRACTOR AWAY FROM THE MACHINE.

WARNING

Do not operate quadrant lever or machine controls through the rear cab window whilst standing on or amongst linkage components. Always seek assistance.

Select a firm level site for parking the machine.

Replace parking legs in their sockets and secure in their lowest position.

Raise the machine on the tractors linkage until the weight is taken off the stabiliser. Remove the lower stabiliser pins.

Unscrew the lift ram tap.

Lower the machine to be ground.

Extend the arms and place the flail head on the ground at half reach.

Disengage tractor P.T.O. and remove.

Disconnect stabiliser bars or loosen check chains as applicable.

Unbolt the control unit from the mounting pillar, remove from tractor cab and stow the levers or switchbox clear of the ground. On Si models only disconnect the supply and return hoses and stow with hose ends clear of the ground.

Disconnect the stabiliser from the tractors top hitch position. Allow the stabiliser to slide along the rail until it contacts the eccentric stops.

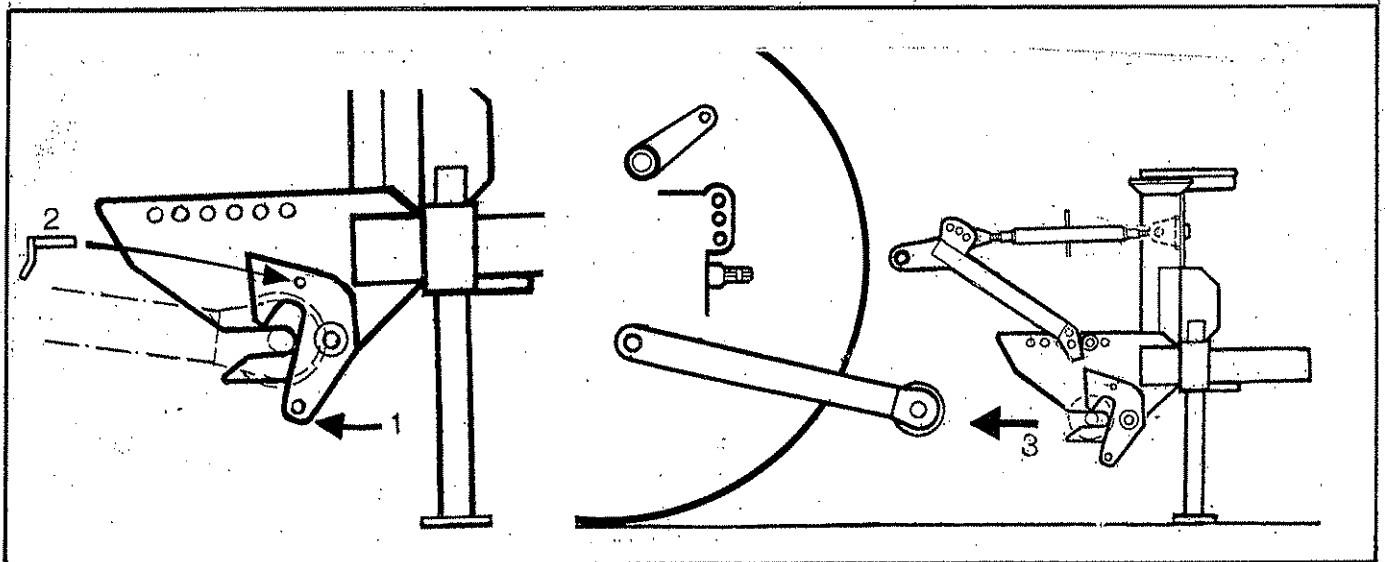

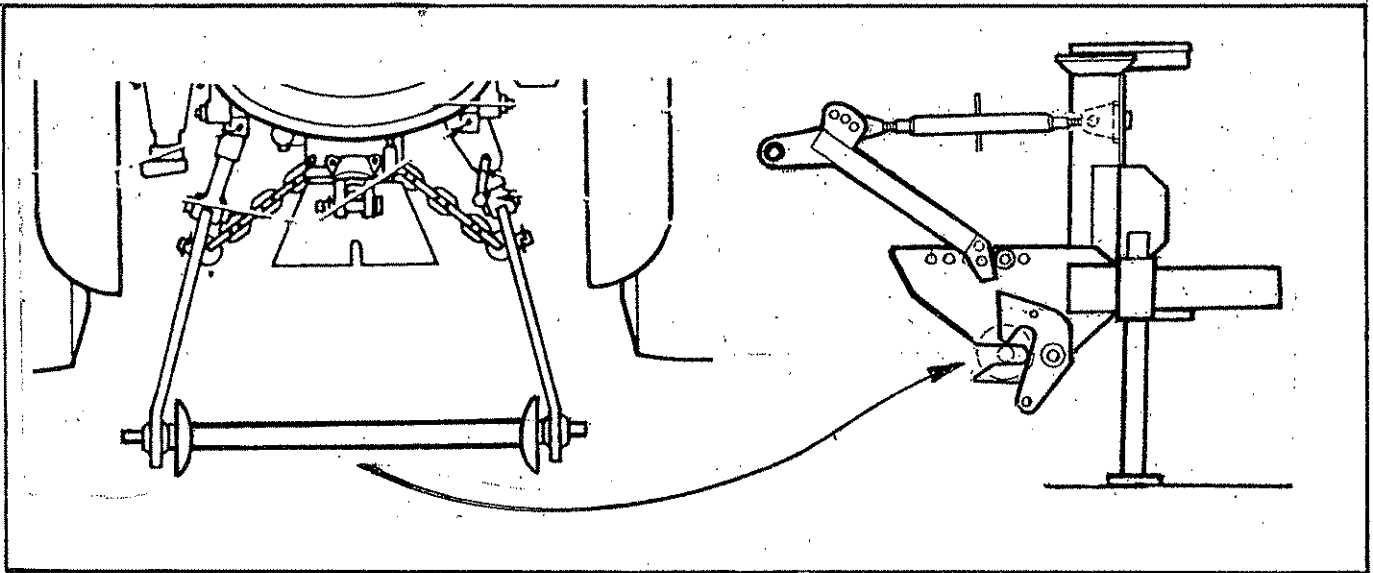

STORAGE

If machine is to be left standing for an extended period of time, lightly coat the exposed portions of the ram rods with grease. Subsequently this grease should be wiped off before the rams are next moved.

If the machine has to be stored outside tie a piece of tarpaulin or canvas over the control assembly do not use a plastic fertilizer bag which could lead to rapid corrosion.

SUBSEQUENT ATTACHMENT TO IDENTICAL TRACTOR

Refer to "initial attachment to tractor" and follow step 6

Connect stabiliser into tractors top hitch position used previously

Raise the machine on the tractors linkage until the stabiliser contacts the eccentric stops.

Fit stabiliser lower pins.

Mount controls in cab.

Fit PTO shaft and attach torque chain to a convenient point to prevent the shaft guard rotating.

Place arms in work position at half reach and adjust lift arm levelling box to bring frame horizontal.

Tighten check chains.

Stow parking legs.

Fold machine into transport position (see page 36).

Proceed to the worksite.

SUBSEQUENT ATTACHMENT TO DIFFERENT TRACTOR

Remove stabiliser and top link from machine and separate.

Refer to "initial attachment to tractor" and follow steps:-

6, 7, 8, 9, 10, 11, 12, (13 Si only), 16, 17, 18, 19, 20, 24, 25, 26, 27.

OPERATION

OPERATOR GUARD

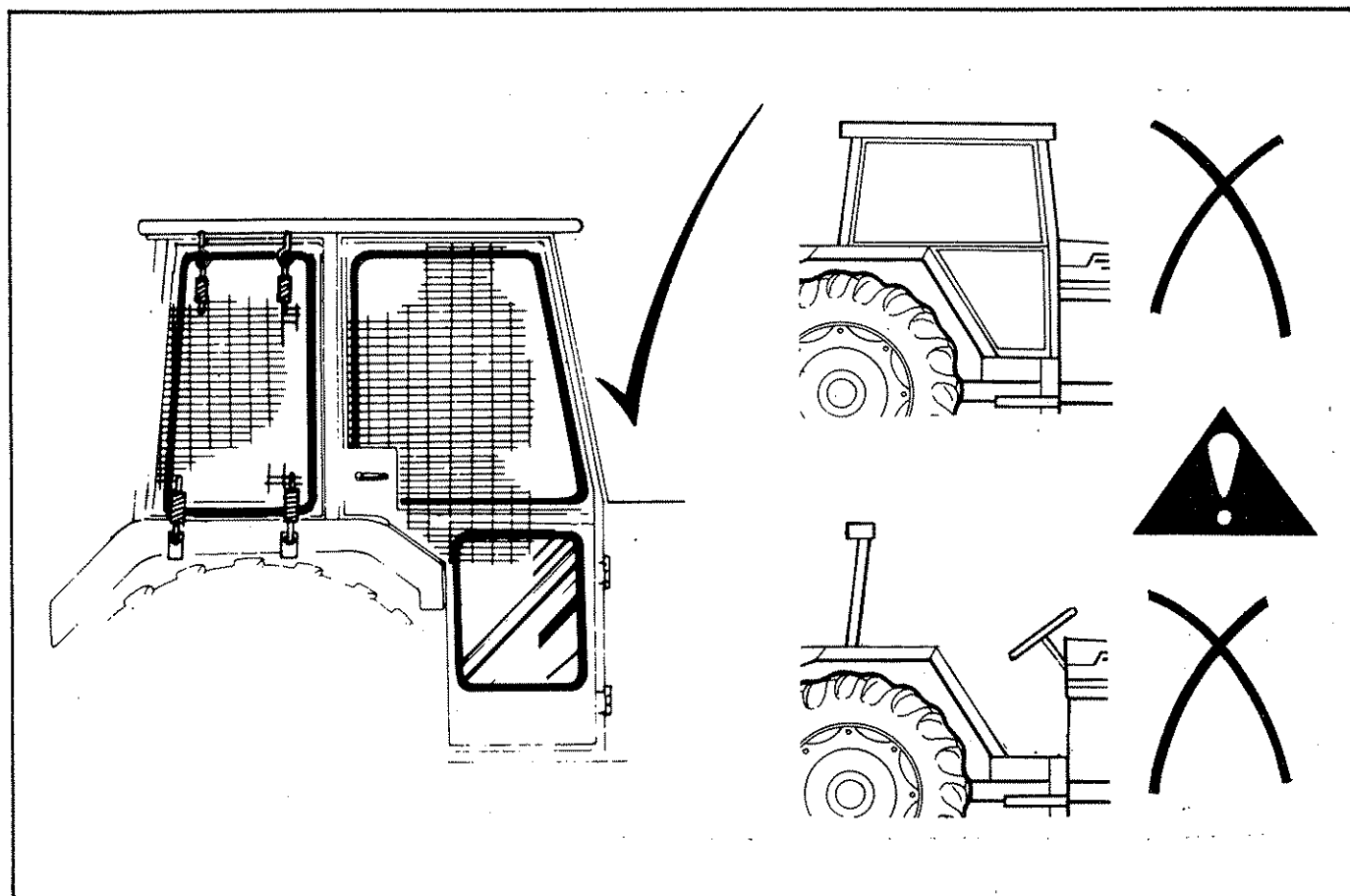

PREPARATION

Read the book first

Practise in an open space without rotor running until familiar with controls.

Caution: Take care when working with the head close in as it can hit the tractor.

TRACTOR CONTROLS

For Si models only the tractors linkage will need to be isolated.

MACHINE CONTROLS

Cable controlled models only

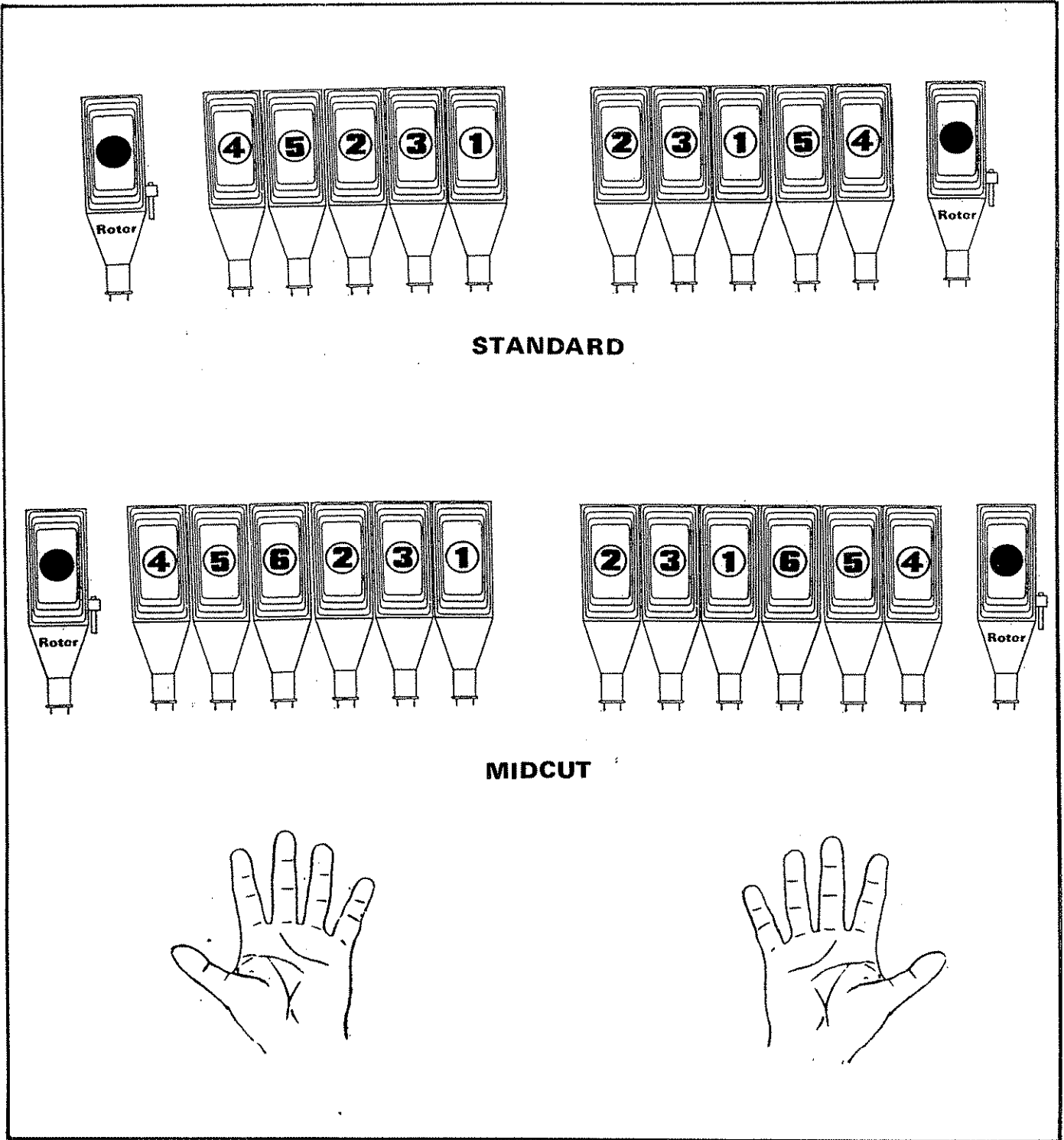

lever functions

5

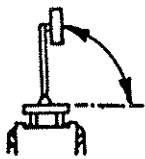

Slew - Allows slew working



Auto reset - Allows normal working

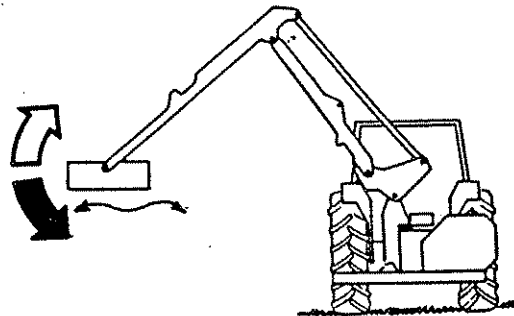
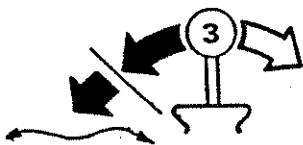
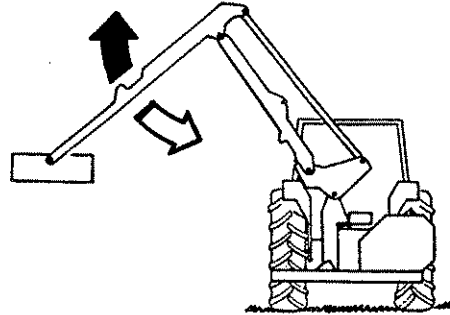
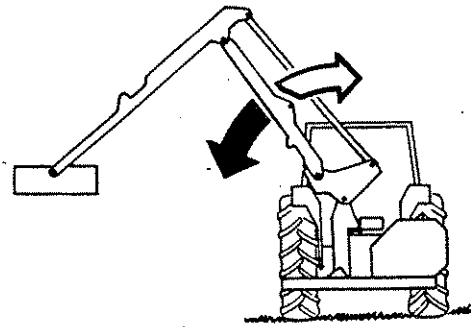

An angle 'float' position can be selected which allows the flail head to automatically angle itself to follow the contours of the ground. To obtain this position the control lever must be pushed away from the operator beyond its normal range until it locks into the float position. To return to normal operation the float position must be manually deselected. When working with head angle float the flail head must be in balance about its mounting point. Failure to observe this will result in a poor untidy finish.

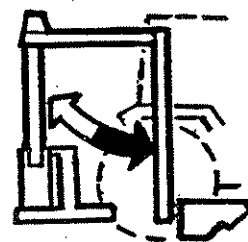
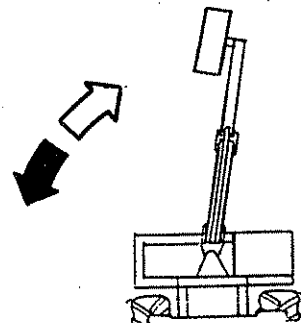
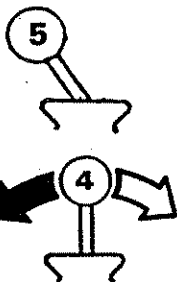

ARM CONTROLS - Electric controlled machines only

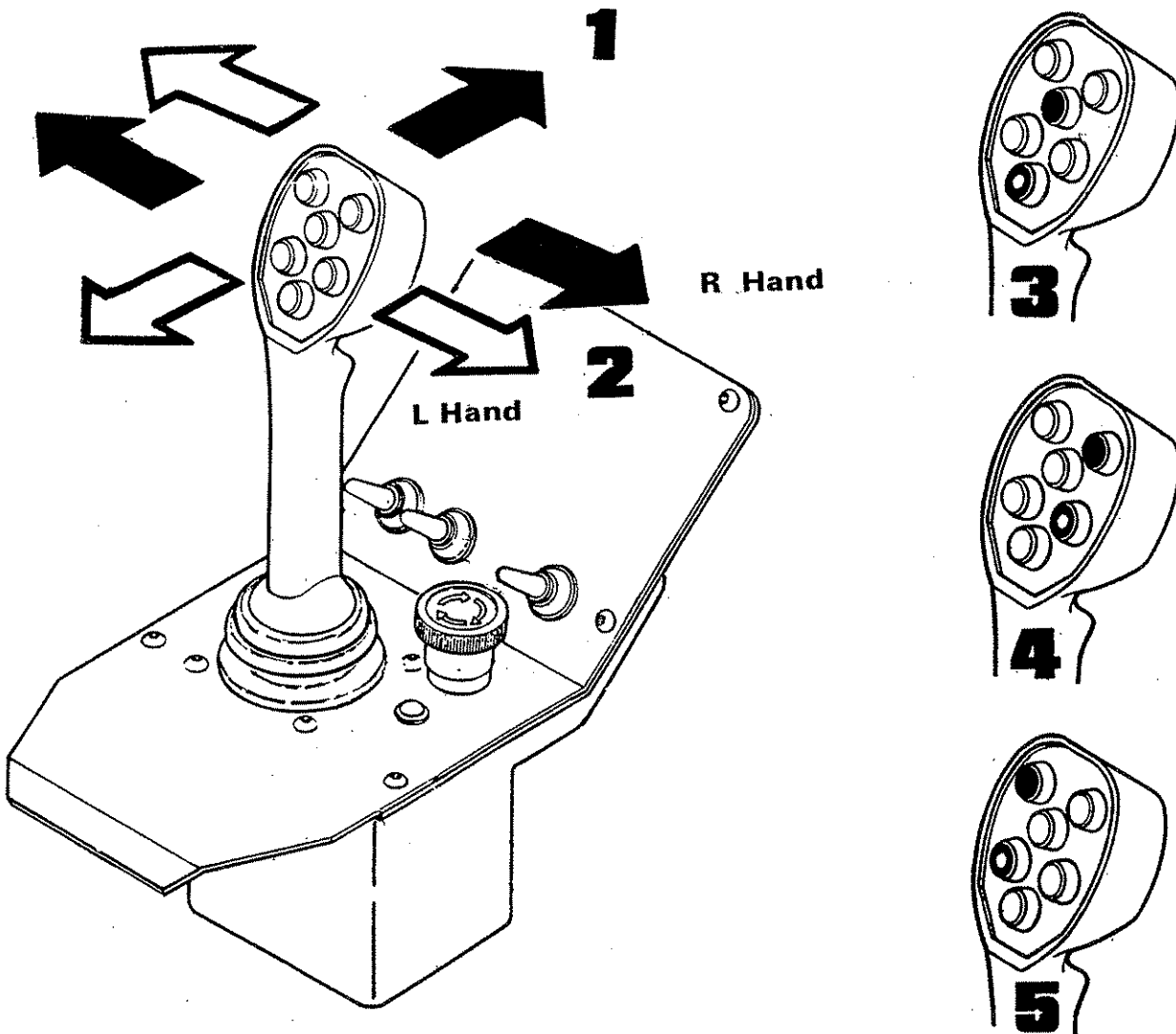
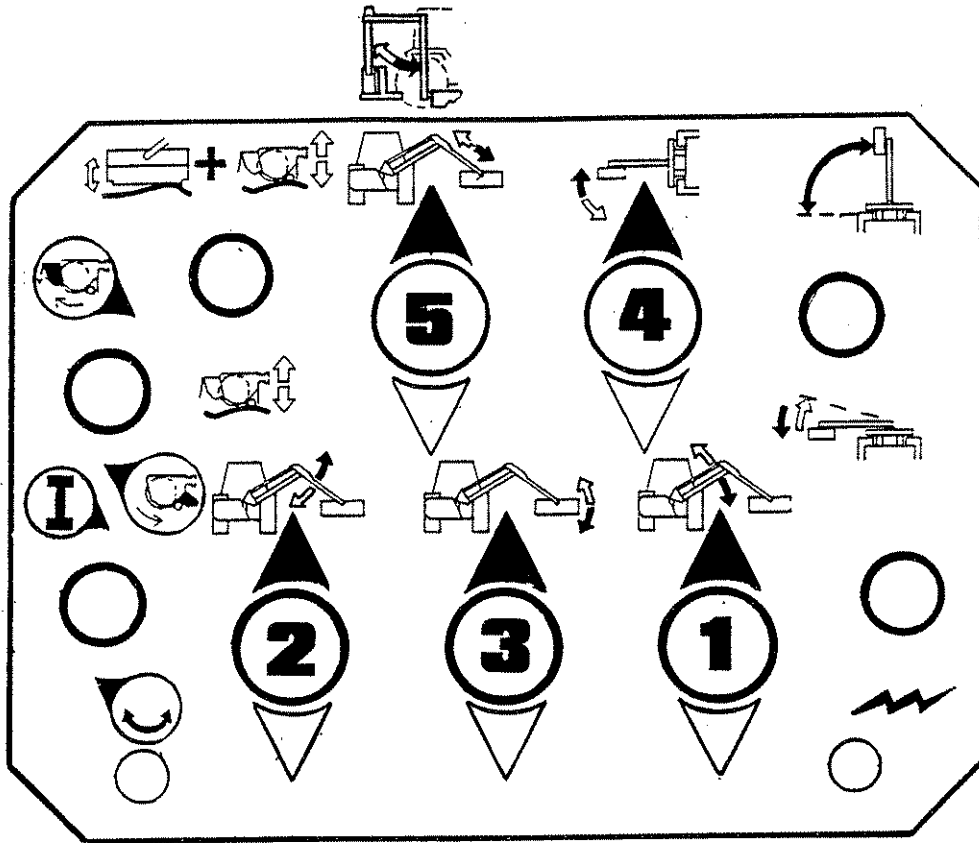

lever functions

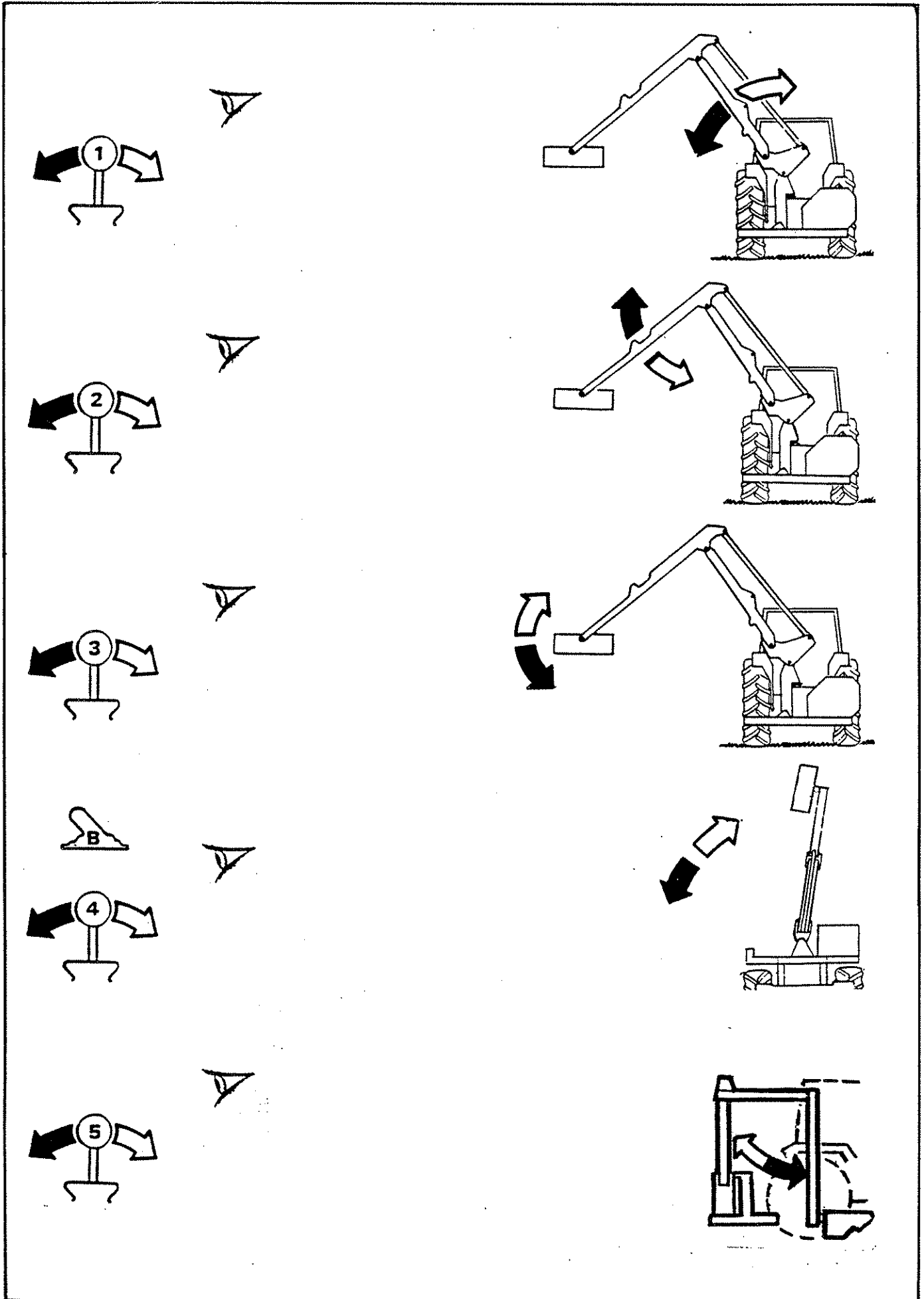

SWITCH FUNCTIONS - Electric controlled machines only

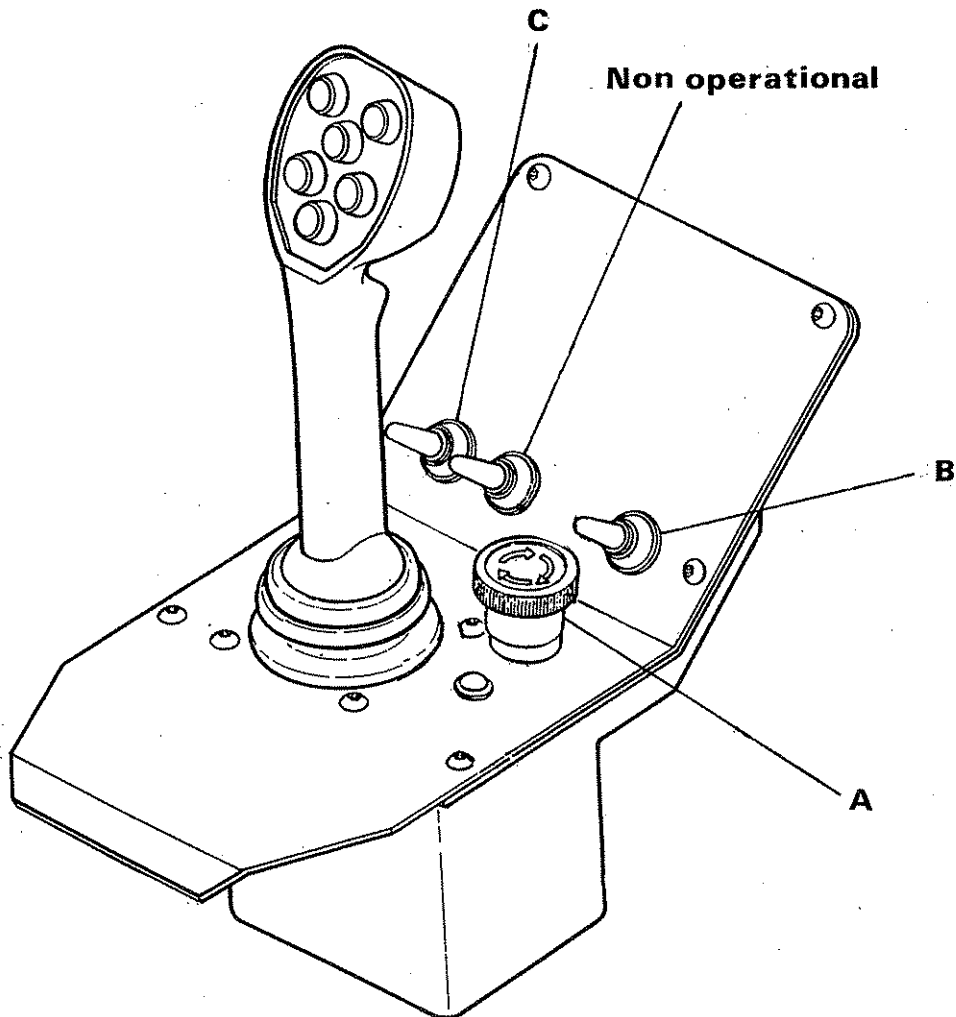
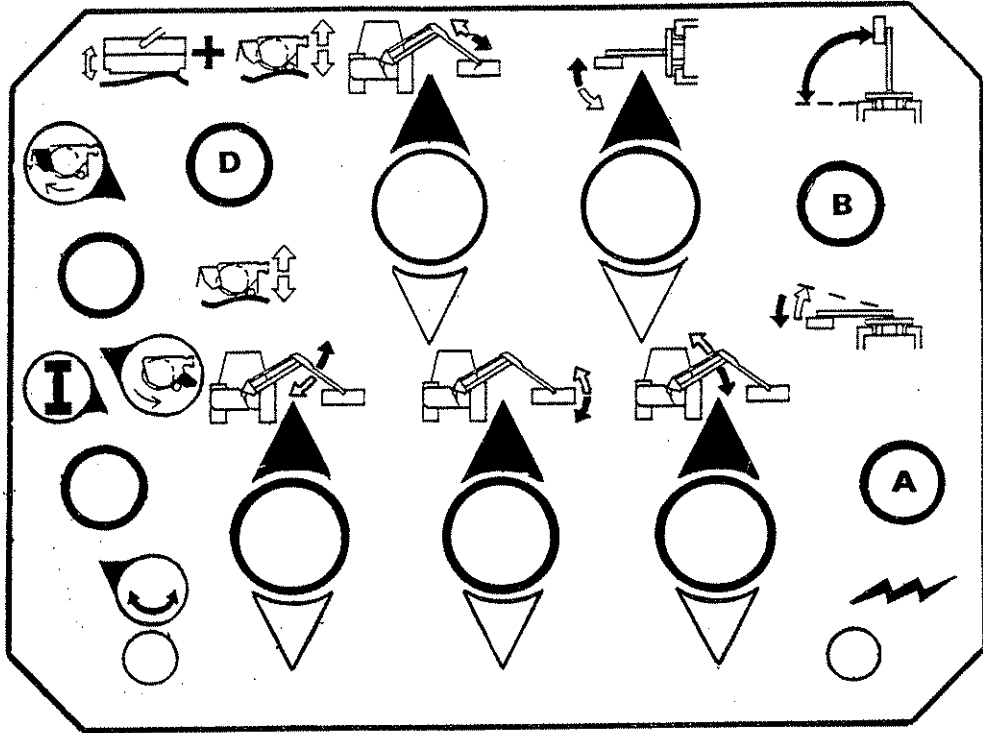

A Power on/off.
On monolever controls turn clockwise for 'on' and push down for 'off'

B

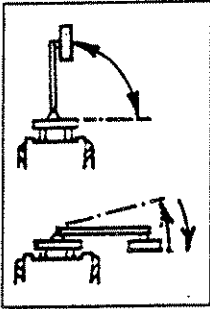

Slew - allows slew working

Auto reset - allows normal working

C Lift float on/off - if fitted

Angle float on/off - if fitted

D Head float on/off - if fitted

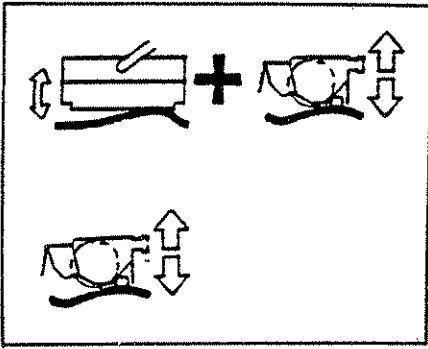

Allows lift and angle float in unison.

Allows lift float selection alone.

ROTOR CONTROLS - Gear hydraulic machines only

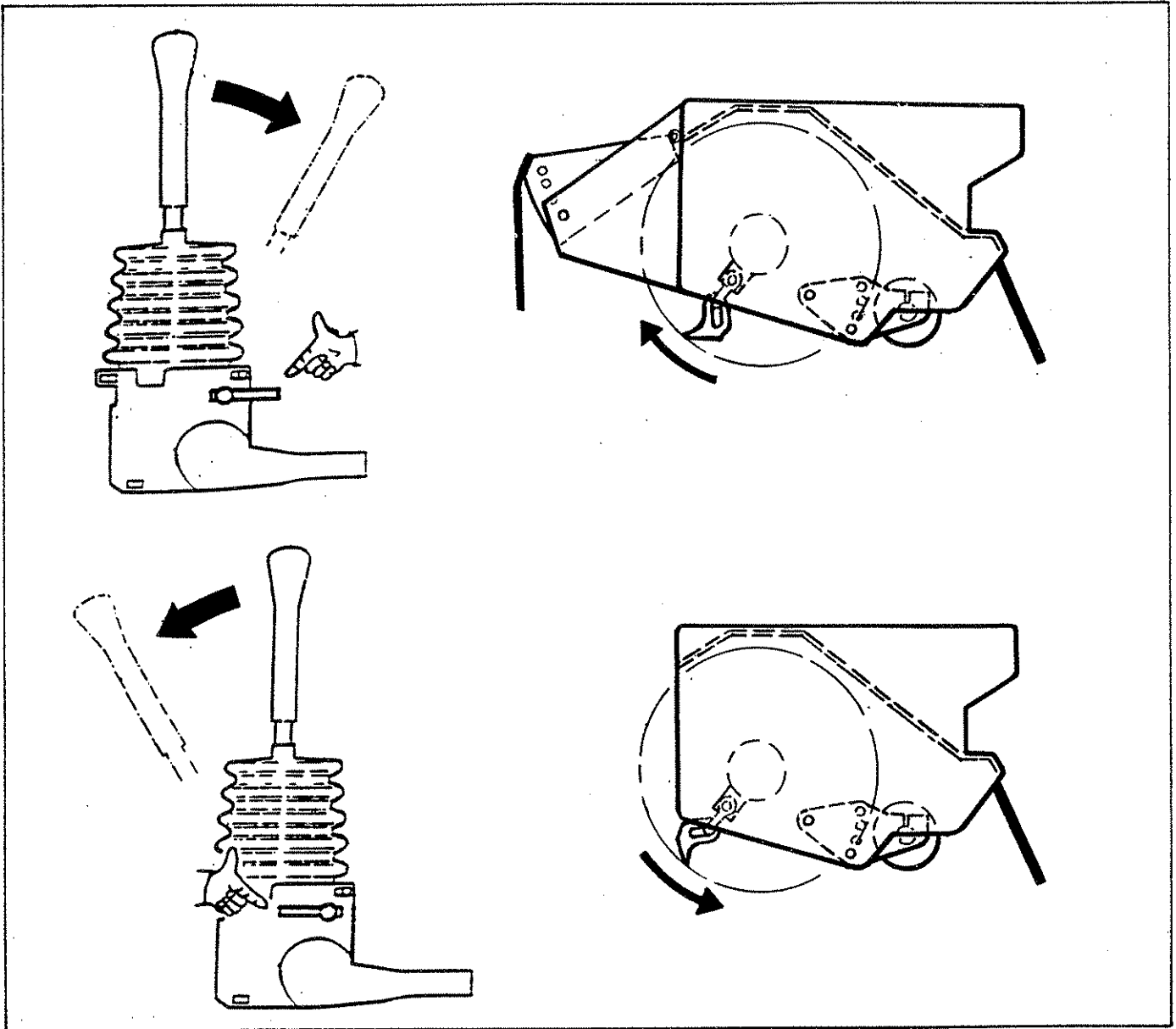

REVERSING ROTATION - Gear hydraulic machines only

Select "Rotor OFF"

Wait until the rotor has stopped turning.

Turn the small lever on the side of the rotor control lever pivot box through 180 degrees. This will reset the control lever stop inside the pivot box and allow opposite rotation to be selected.

ROTOR CONTROL - S.i. machines only

Rotor on/off is controlled by operation of the tractors P.T.O. lever

To start rotor:-

Bring tractor engine revs up to 1000 RPM

Engage P.T.O.

To stop rotor:-

Disengage P.T.O. Do not leave tractors seat until the rotor is stationery.

Reversing rotation - S.i. models only

Fully extend the armhead and lower flail to the ground to minimise oil loss.

Release the hoses from the rotor relief valve and interchange. Do not interchange the flail supply and return hoses at any other point as the hose routing and cross overs in the installation are necessary to allow the hoses to flex correctly during arm movements.

To ascertain the direction of cut without running the machine the following applies.

Connection P - lower motor rigid pipe) upward cutting
Connection MR - Upper motor right pipe)

Connection P - Upper motor rigid pipe) downward cutting
Connection MR - Lower motor rigid pipe)

BREAKAWAY

The machine is fitted with a hydraulic breakaway device which protects the structure of the machine should an unforeseen obstacle be encountered.

Note:- The breakaway function does not relieve the operator of his responsibility to drive carefully, be alert and to avoid obvious hazards before contact occurs.

Breakaway may occur momentarily during normal work should an extra thick or dense patch of vegetation be encountered. In these instances tractor forward motion may be maintained with care.

Where breakaway has occurred as a result of contacting a post or tree etc. the tractor must be halted and the controls of the machine utilised to manoeuvre the head away from the obstacle. **NEVER CONTINUE FORWARD MOTION TO DRAG THE HEAD AROUND THE OBSTACLE IN BREAKBACK POSITION.**

Note:- The force required to activate the breakaway system will vary dependent upon the gradient of work. It will require less force when working uphill and vice versa.

On midcut machines the geometry of the breakaway will cause the head to initially move outwards in addition to rearwards. Therefore be aware that the breakaway action will be impeded if the outer end of the head is working against a steep bank. In this circumstance extra care must be taken during operation to avoid this occurrence.

Breakaway occurs at the slew column pivot. When an obstacle is encountered continued forward motion causes the pressure in the slew ram base to rise until the relief valve setting is exceeded.

With 'AUTO RESET' selected:-

When the slew relief valve setting is exceeded oil is displaced from the slew ram into the base of the lift ram which causes the head to rise as the arm pivots backwards to clear the obstruction. Re-setting of the head into the work position occurs automatically.

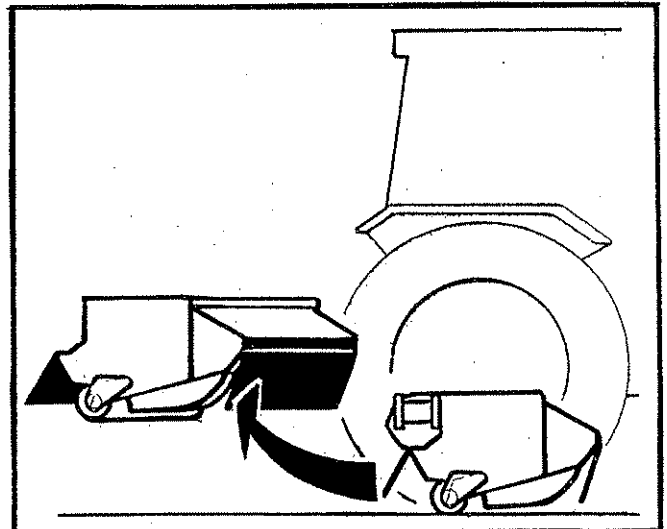

With 'SLEW' selected:-

When the slew relief valve setting is exceeded oil is displaced from the slew ram allowing the arm to pivot backwards horizontally and the obstacle to be cleared.

Re-setting the head into the work position is carried out manually by selecting 'SLEW OUT' on the control assembly.

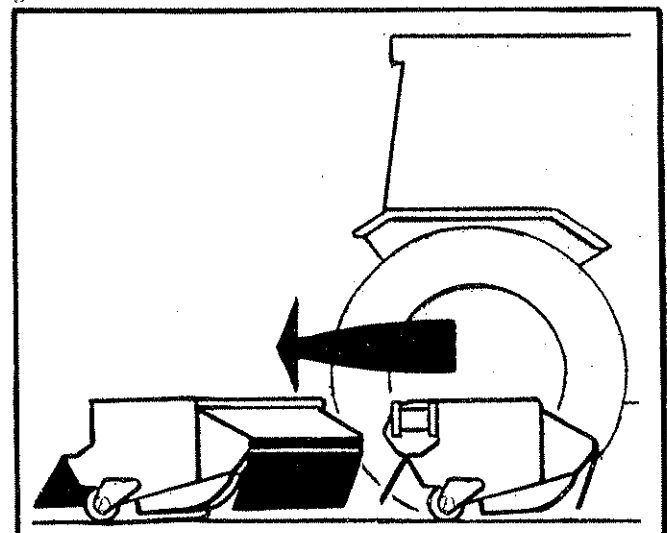

POWERED SLEW

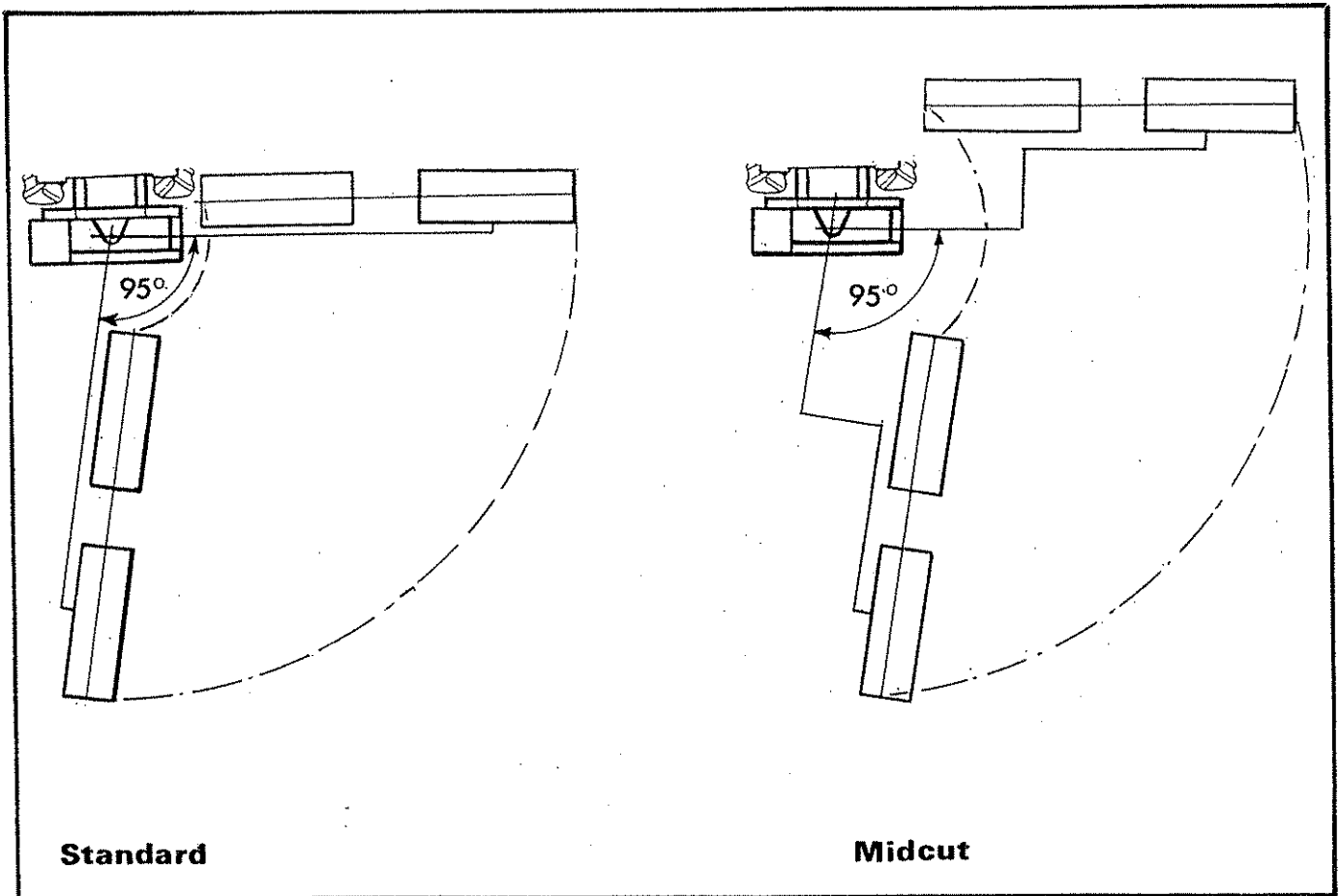

The slew feature allows a 95° arc of powered arm movement on the working side from right angles to the tractor to 5° beyond the direct line astern.

the feature is required to place the machine in the transport position but can also be used to sweep the arm to and fro whilst cutting awkward areas and corners thus avoiding the need to constantly re-position the tractor.

To operate in this way 'SLEW' must be selected on the control assembly.

If breakaway occurs the slew motion must be reversed to allow the slew breakaway relief valve to re seat and the ram to become operable again.

Caution: Extra care must be taken when working in 'SLEW' mode with the reach fully in as it is possible for the flail head to bit the tractor or machine frame.

A.H.C. - Automatic head control

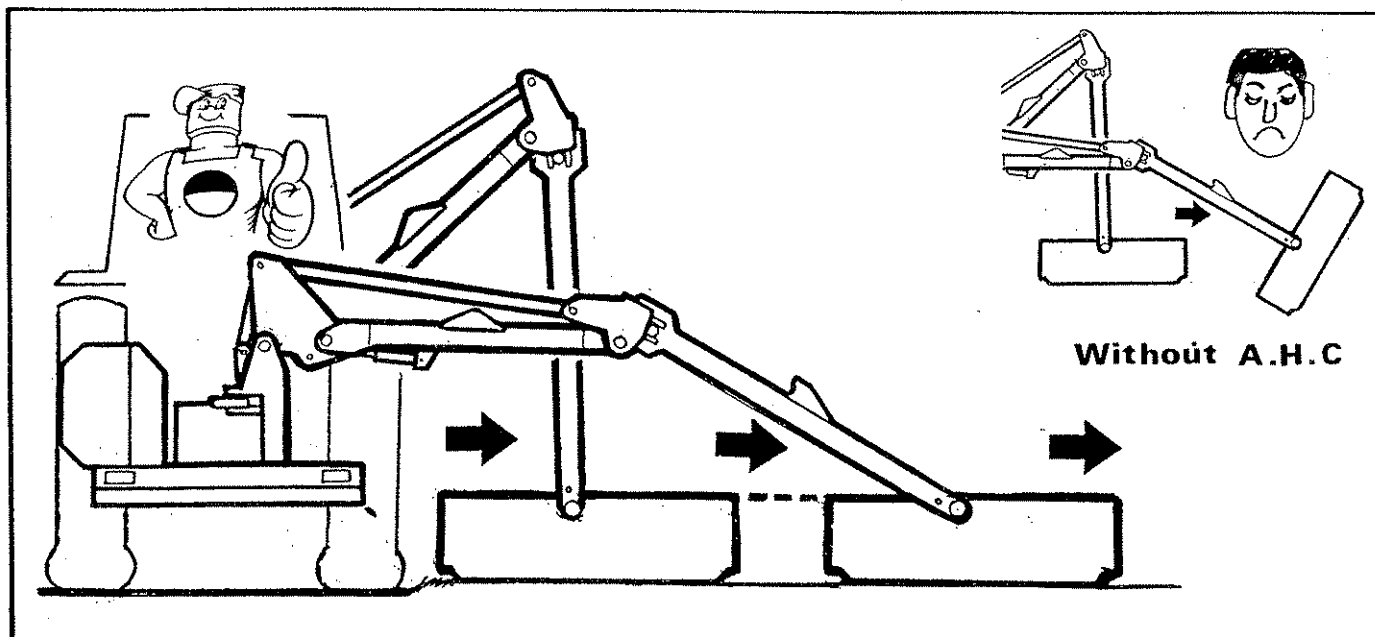

A standard feature comprising of a system of compensator rams sensing movement of the lift and reach services and linked to the angling ram which enables the flail head to remain in its set position regardless of adjustments in lift and reach settings.

When used during hedge cutting or mowing in conjunction with the machines parallel motion geometry it greatly reduces the number of control movements required by the operator.

Note: The performance of the function deteriorates when working within half a metre of full reach.

Should "head angle float" be selected the auto head control feature ceases to function. On de-selection it becomes automatically re-instated.

WIRE TRAP

The flail head is equipped with a wire cutting edge welded into the underside. This is to ensure that the ends of any wire that may be entwined in the rotor are cut and do fall within the confines of the flail head. This plate should not be interfered with in any way.

Any wire caught in the rotor must be immediately removed.

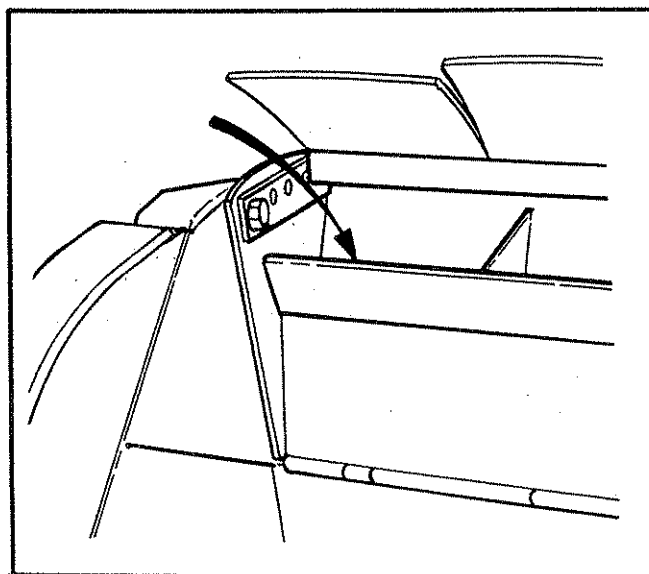

REMOVING WIRE

Select rotor "OFF" and wait until it has stopped rotating.

STOP the tractor and only then remove wire.

Do not reverse the rotor in an attempt to unwind any wire.

MOVING INTO THE TRANSPORT POSITION

Select "ROTOR OFF" and wait until the rotor has stopped turning.

Ensure that the lift and angle float are switched off.

Select "SLEW" mode on the control assembly.

Operate "SLEW IN"

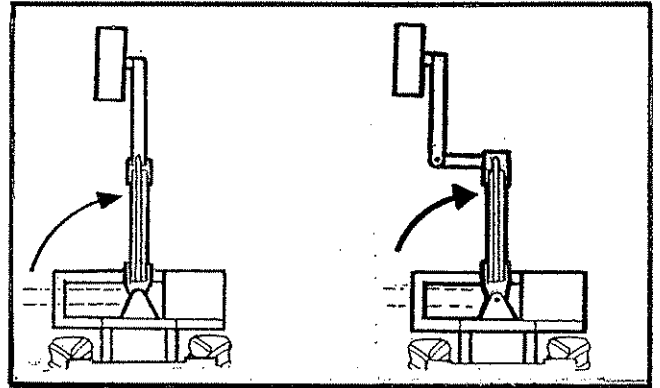

Operate "LIFT" and "REACH" to place the flail head on the ground.

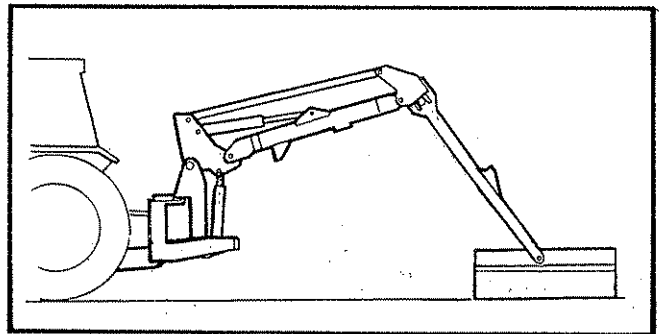

Remove the transport cradle from its stowage position and pin in place beneath the main arm.

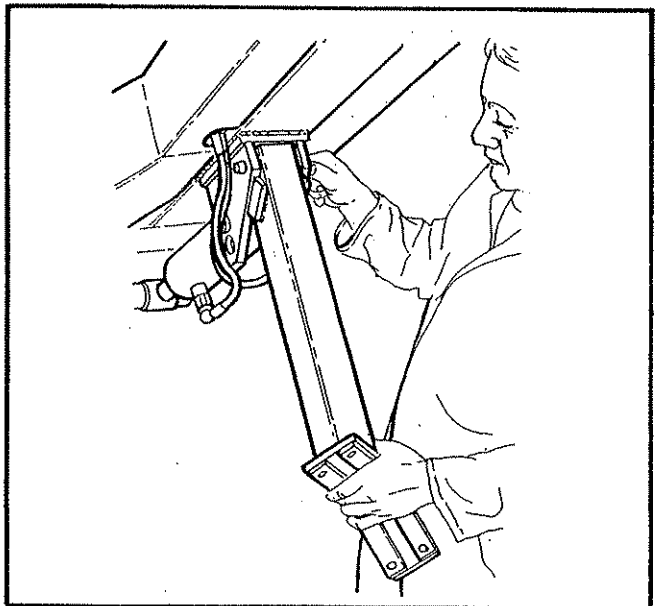

Operate "LIFT" and "REACH" to position the machine as diagram.

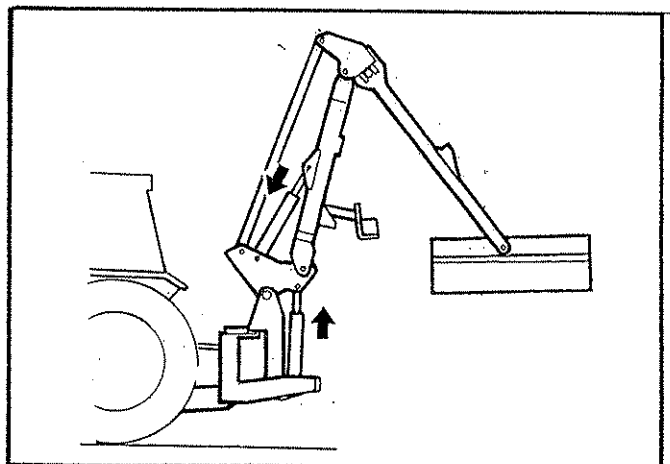

(midcut model)

Fully retract the midcut transport ram.

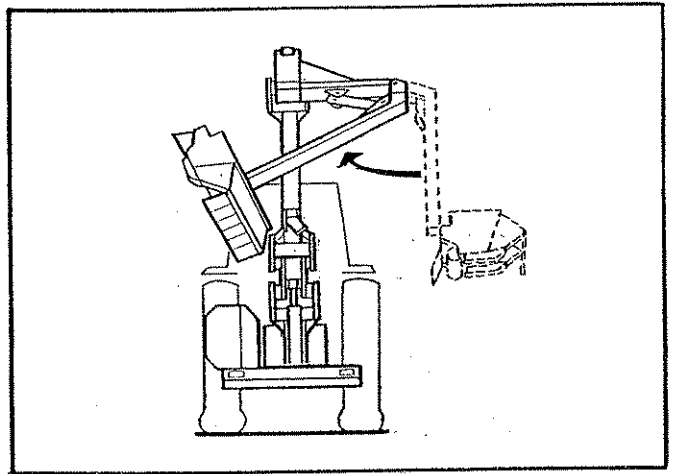

Operate "REACH IN" until the dipper arm contacts the transport cradle.

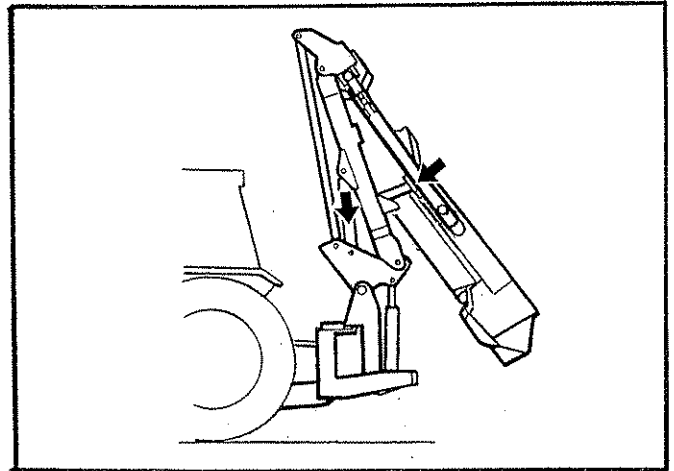

Select "LIFT UP" and raise the arms until the tension link is 300mm from the tractor cab.

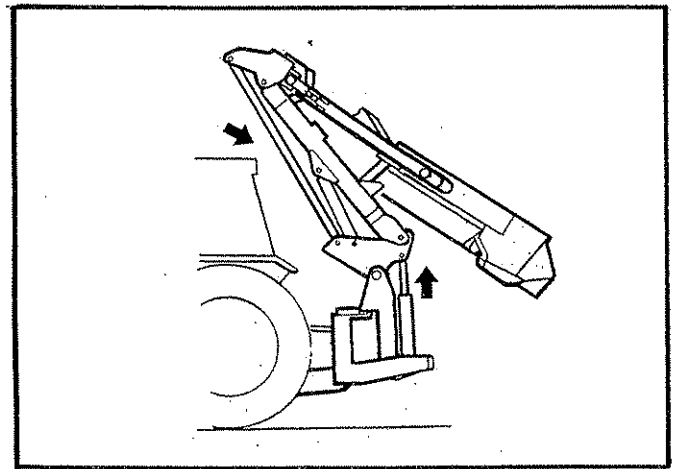

Operate "ANGLE" and position the flail head in as compact a position as possible - See transport position.

Full screw in the lift ram tap.

TRANSPORT POSITION

The machine is transported in line to the rear of the tractor with a minimum of 300mm clearance between the tension link and the rear cross member of the tractor cab.

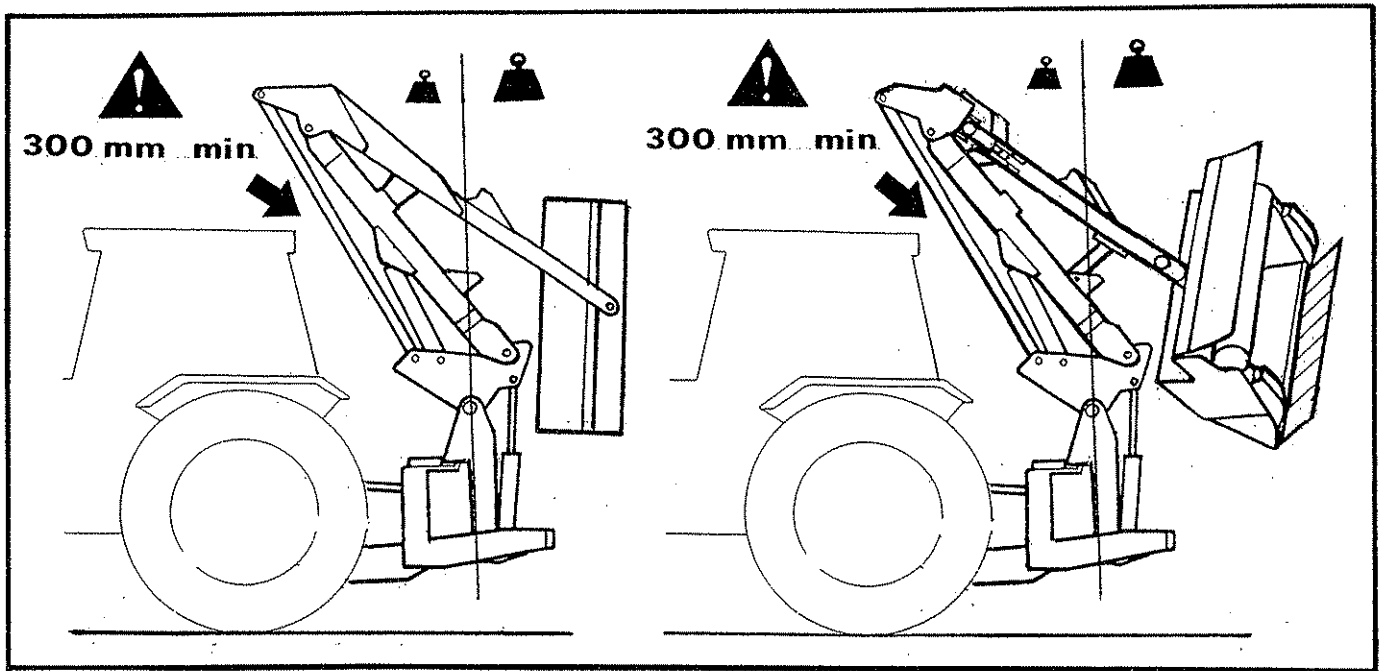

TRANSPORT POSITION WITH HEAD REMOVED

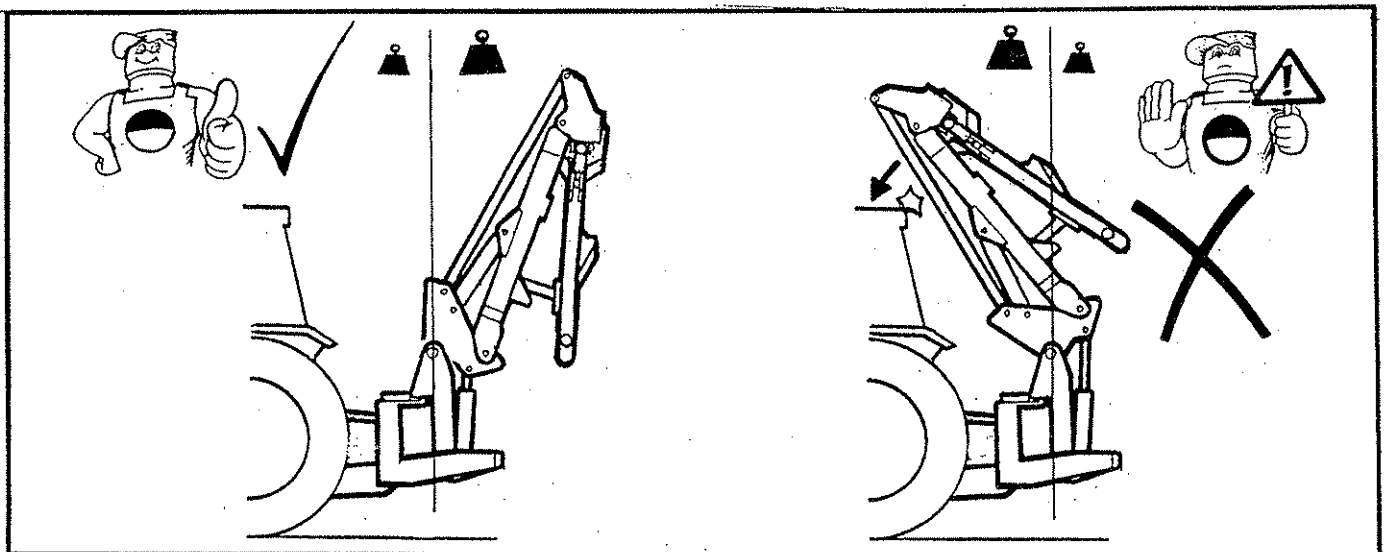

With the flail head removed the arms are fully folded but the lift ram remains retracted. If the lift ram is extended the weight of the arms will cause the balance of the machine to go over centre causing the tension link to crash into the rear cross member of the tractor's cab.

WARNING

During transport the "SLEW" mode must always be selected on the control assembly.

TRANSPORT

When in transport the P.T.O. must be disengaged and the power to the control box switched off.

The acceptable speed of transport will vary greatly depending upon the ground conditions.

In any conditions avoid driving at a speed which causes exaggerated bouncing as this will put unnecessary strain on the tractors top hitch position and increase the likelihood of the tension link contacting the cab rear cross member.

TRANSPORT HEIGHT

There is no fixed dimension for transport height. It will vary depending on the height that the machine is carried and the degree of arm fold that the rear of the cab will allow.

For the majority of installations the transport height will generally fall between a minimum of 3.45m and a maximum of 3.65m when the machine is correctly folded.

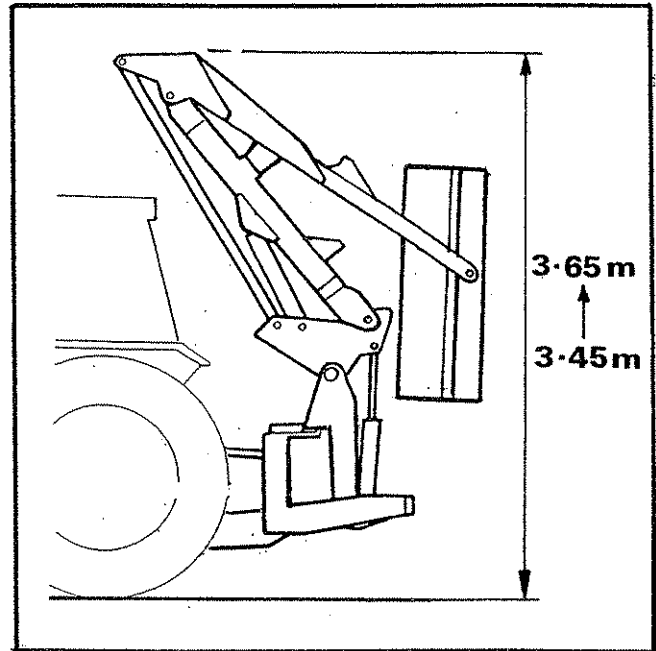

MOVING FROM TRANSPORT TO WORK POSITION (all models)

To revert to the work position the previous procedures for the relevant models are largely reversed.

Remember to unscrew the lift ram tap

ENGAGING DRIVE

T.i. models only

Ensure that the rotor control lever is in the 'Stop' position before engaging the P.T.O. shaft. Allow the oil to circulate for a minute or so before operating the armhead levers. Position the flail head in a safe position, increase the engine speed to a high idle and move rotor control lever to 'START'. After initial surging the rotor will run at an even speed.

S.i. models only

Place the flail head at a safe attitude and bring the tractor engine revolutions to 1000 r.p.m. Engage the P.T.O. and slowly increase revs. until operating speeds are attained.

ROTOR OPERATING SPEED

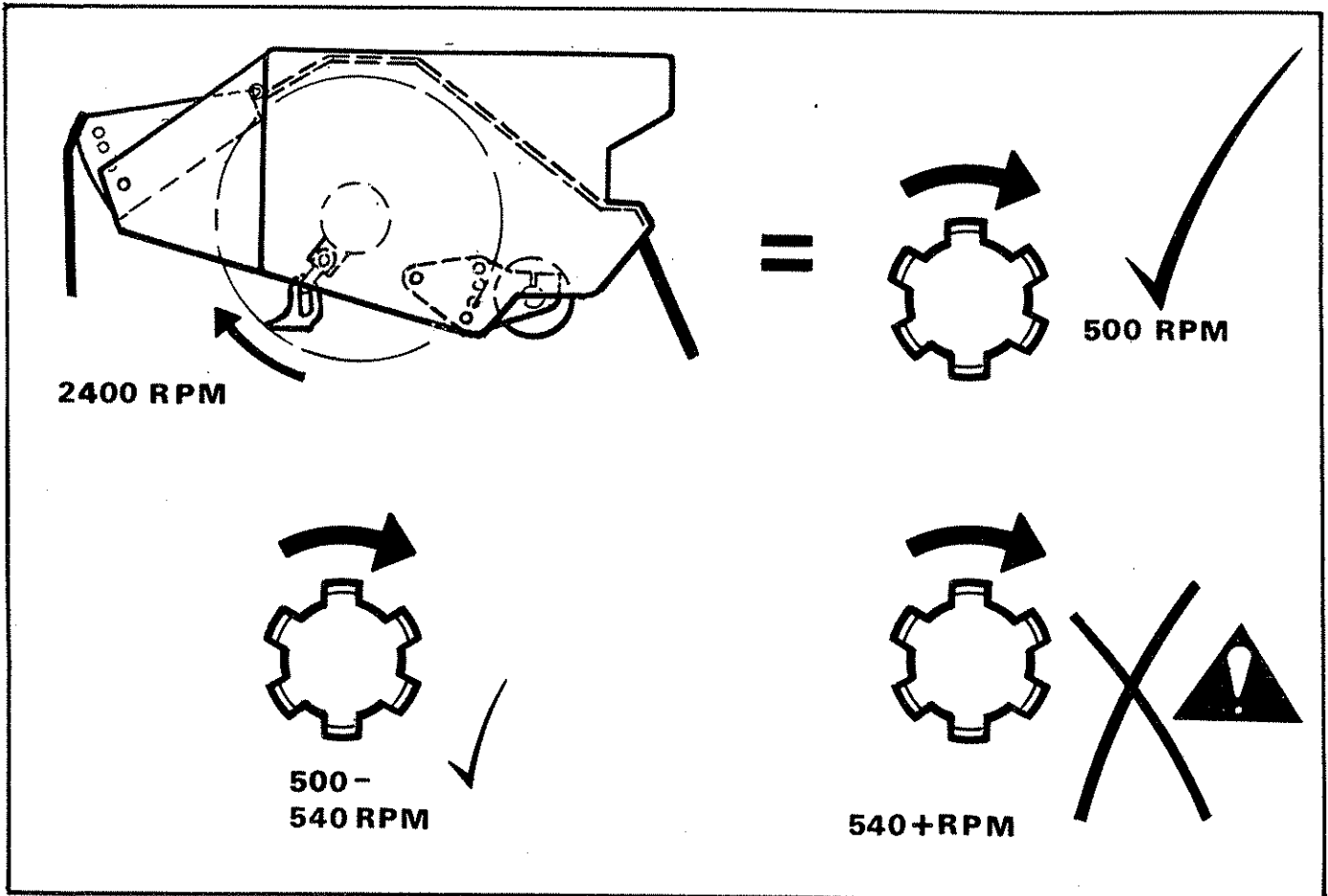

TRACTOR FORWARD SPEED

Tractor forward speed is determined by the material being cut. Forward speed can be as fast as that which allows the flail head sufficient time to cut the vegetation properly.

Too fast a speed will be indicated by over frequent operation of the breakaway system, a fall off in tractor engine revs and a poor finish to the work leaving ragged uncut tufts and poorly mulched cuttings.

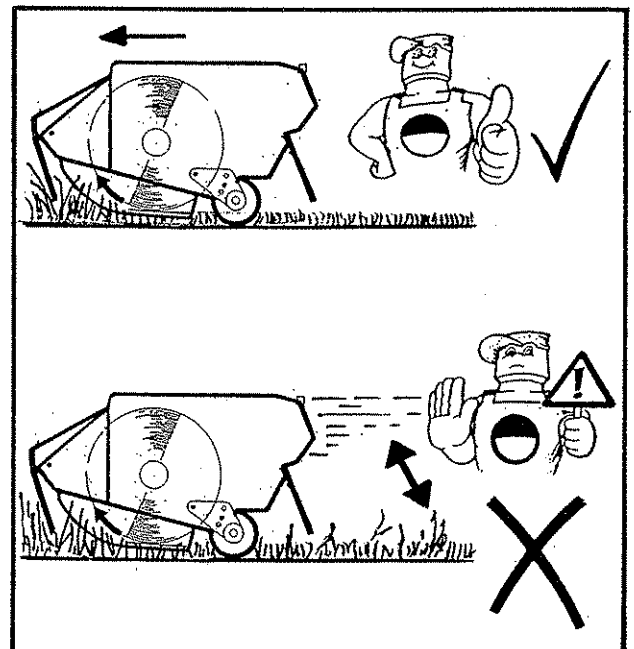

WORKING ON PUBLIC HIGHWAYS

When working on the public highway it is the operator's responsibility to familiarise himself with any national and local regulations concerning this type of activity and to abide by them at all times.

In addition he must remember that there is a potential for debris to be thrown long distances should it escape the head shrouds.

In inhabited areas work should only proceed with extreme caution and any bystanders must be kept away from the potential danger area.

WARNING

It is the operators responsibility to observe these regulations and to keep bystanders at a safe distance.

GENERAL WORKING PRACTISES

It is the operators responsibility to develop safe working procedures.

Always:-

Be aware of hazards in the vicinity.

Make sure all guards are in position and in good condition.

Disengage P.T.O. before stopping the engine.

Wait until the flail has stopped running before leaving the tractor seat.

Disengage the P.T.O. and stop the tractor engine before making any adjustments.

Check frequently that all nuts and bolts are tight.

Keep bystanders at a safe distance.

CUTTING PRECAUTIONS

Inspect the work area, remove any hazardous material and note any immovable obstructions.

HIGH VOLTAGE CABLES

WARNING

Depending on the voltage of the cables and the weather conditions there is a danger of electric flashover if the head or arms approach the cables too closely.

Always maintain a minimum clearance distance of 1.5m when operating near high voltage cables.

If in any doubt consult your local electric company regarding a safe procedure for work.

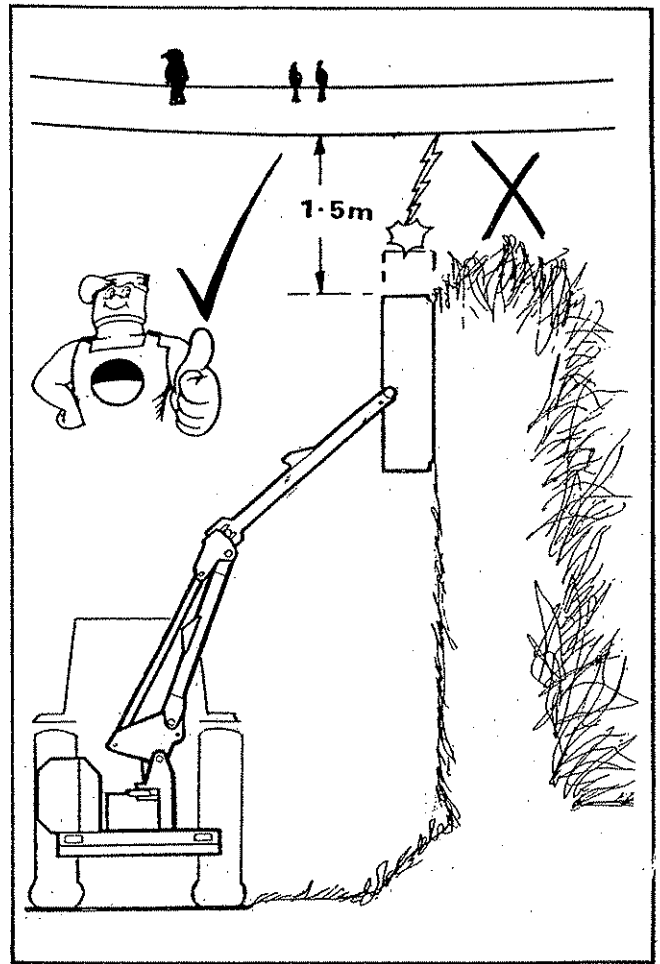

OVERHEAD OBSTRUCTIONS

Always be aware the machine is approximately 4 metres high when folded and take care when manoeuvring in areas with overhead obstacles especially power cables, low bridges etc. or when entering buildings.

HEDGE CUTTING PROCEDURE

1. Cut the side and bottom of the field side first. This leaves the maximum thickness of hedge on the road side to prevent the possibility of any debris being thrown through the hedge into the path of oncoming vehicles.

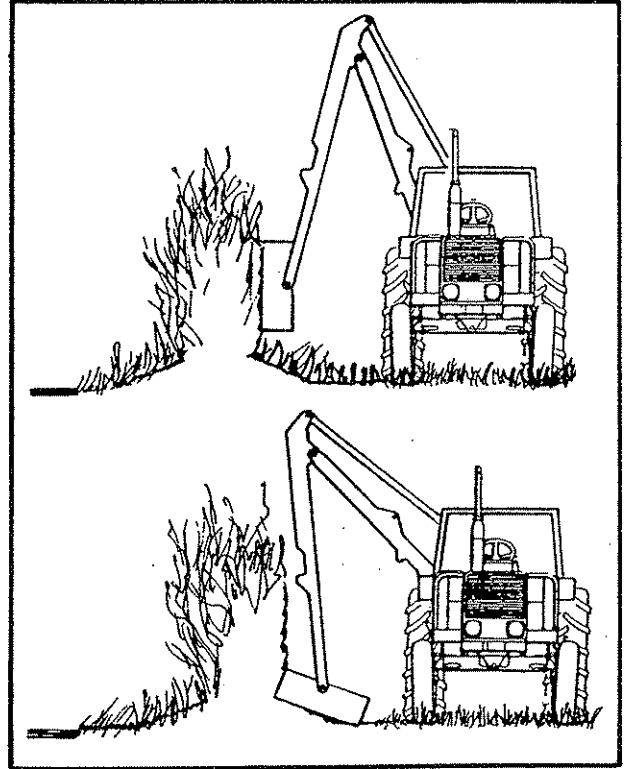

2. Cut the side and bottom of the road side.

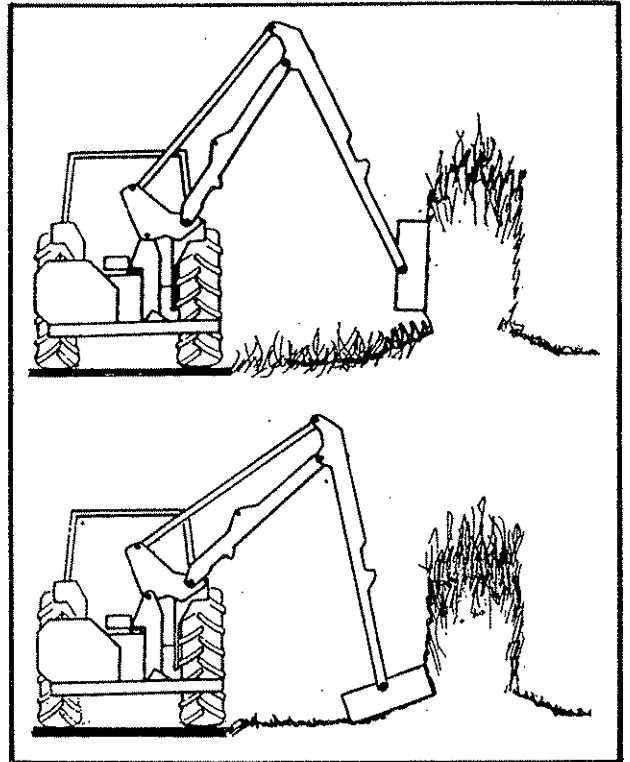

3. Top cut the hedge to the height required.

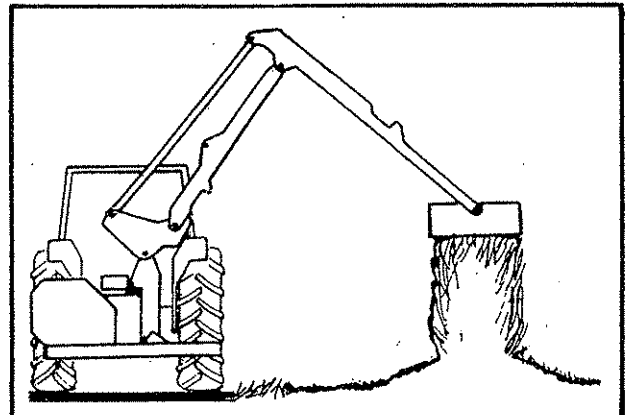

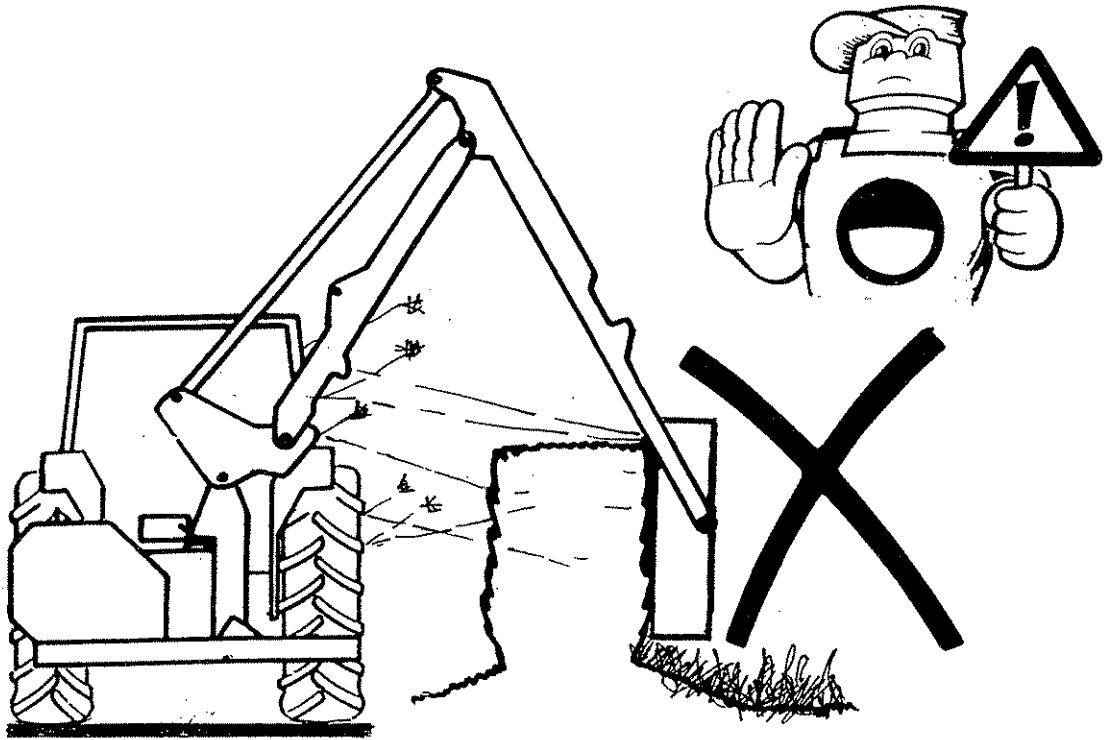

WARNING

Never cut over the far side of the hedge. It is impossible to see any potential hazards and the position of the flail head will allow the possibility of debris being thrown through the hedge towards the tractor and operator.

WORKING ON ADVERSE SLOPES

When working high with the reach fully in it is possible for the main arm balance to go overcentre and take the weight off the lift ram. A restrictor in the gland connection of the lift ram prevents sudden unpredictable movements should this occur.

WARNING

Do not remove this restrictor from the lift ram gland connection.

To regain the lower position extend the reach ram to return the centre of balance onto the lift ram which will then retract when 'Lift down' is selected.

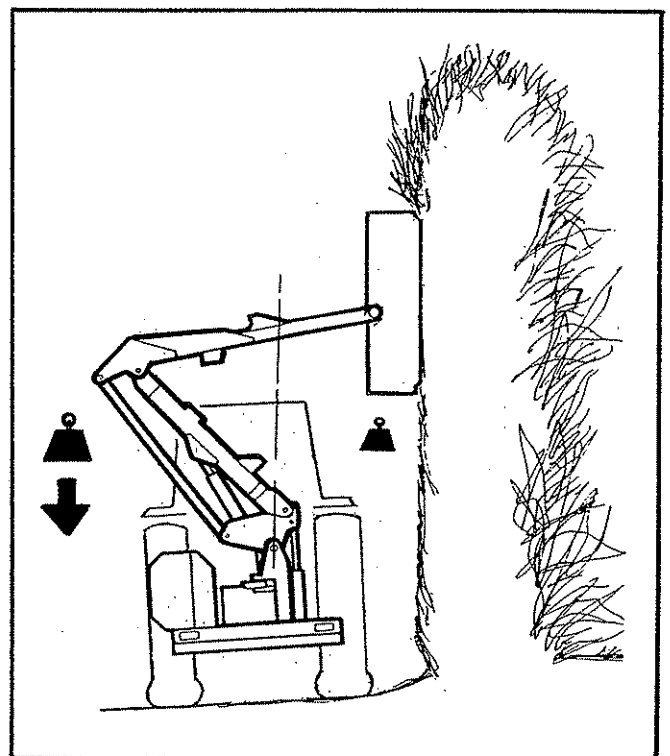

LIFT FLOAT KIT (Optional extra for ground cutting)

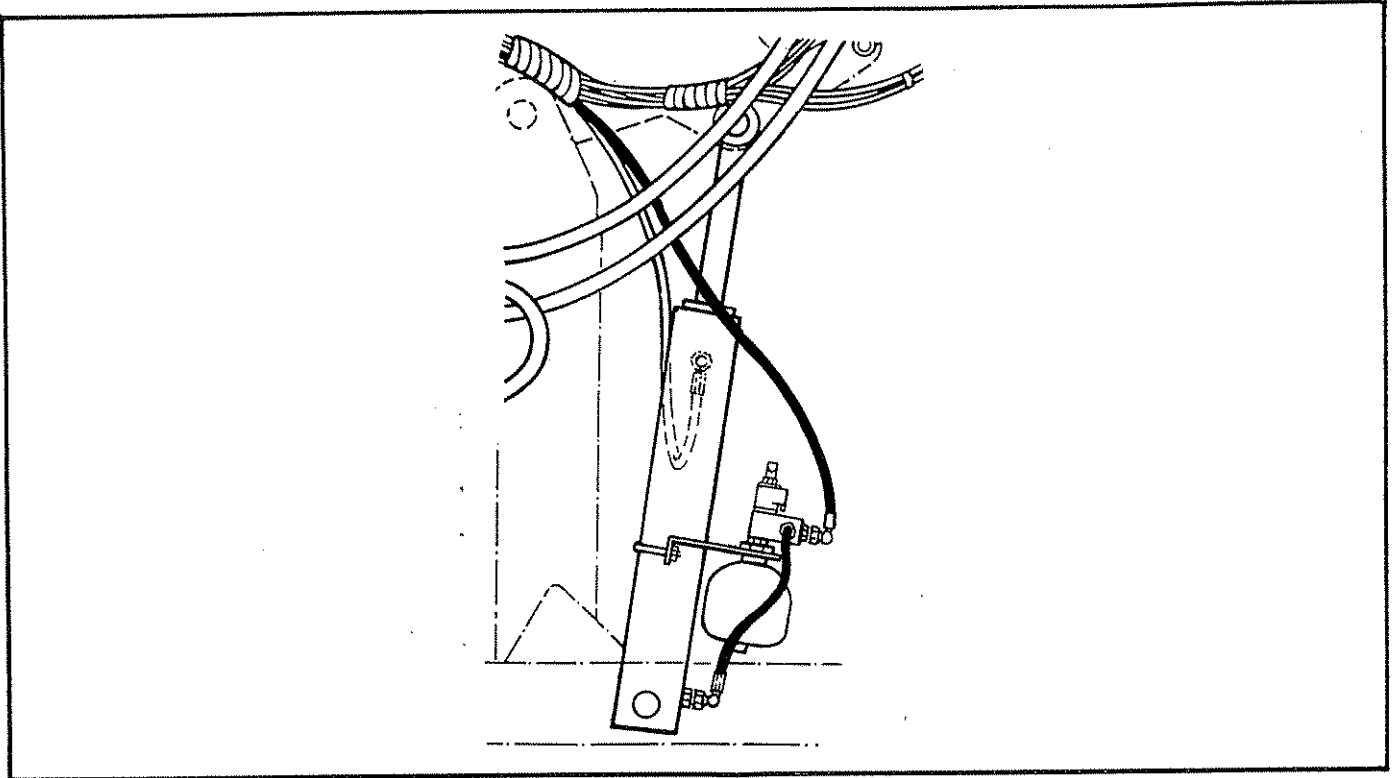

The hydraulic float kit should be mounted as shown clamped to the lift ram barrel in such a position that it does not foul any other component during the slewing motion.

On cable controlled machines the switch is mounted in a convenient location in the cab. The supply cable from the poppet valve solenoid is connected into the tractors ignition system. The brown lead is positive and the blue is negative.

On electric controlled machines the cable from the poppet valve solenoid is connected to the auxiliary switch on the control unit. It is permissible to also have the angle float facility connected to the auxiliary switch. In this case both functions will operate in unison.

The auxiliary switch on multilever electric controlled machines is a three position type which will allow the selection of head float alone, or head and angle float in unison, if both options are fitted.

For multilever switchboxes an additional switching kit Part No. 84 02 303 is available which will, when the dual action position is selected, isolate the lift float function and allow angle float to be selected alone.

In work with the solenoid valve open the flail head will automatically follow the ground contours.

The float action is engaged by selection of the auxiliary switch

The lift control should be operated to take a proportion of the flail head weight off the flail roller. This is important, too little weight on the roller will leave areas of grass while with too much weight on the roller the ground will be scalped in places and increased flail wear, damage, or even loss of flails could occur.

To revert to standard operation the accumulator/s is isolated from the lift ram by deselecting the float switch.

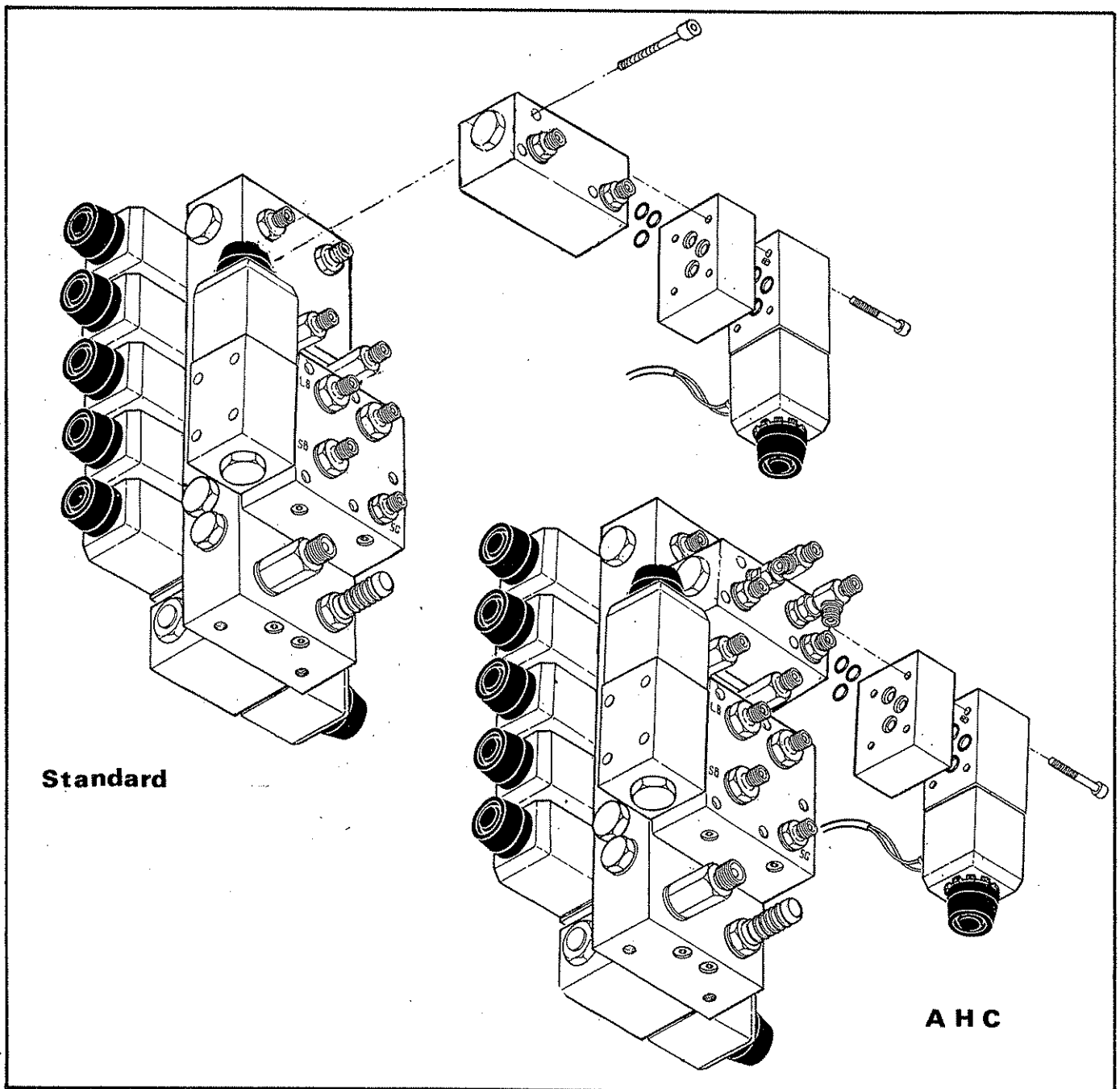

HEAD ANGLE FLOAT KIT - Optional extra on all electric controlled models.

This facility will allow the flail head to angle itself automatically to suit the contours of the ground. It is activated by selecting B

The kit is bolted in position as shown. The existing 'O' rings from the hose plate must be extracted carefully and re-used.

The two core cable is connected from the solenoid to the common link harness and connection 14 on the main harness.

When working with head angle float the flail head mount must be positioned such that the flail head is balanced about the mounting position. Failure to observe this will result in a poor untidy cut.

MAINTENANCE

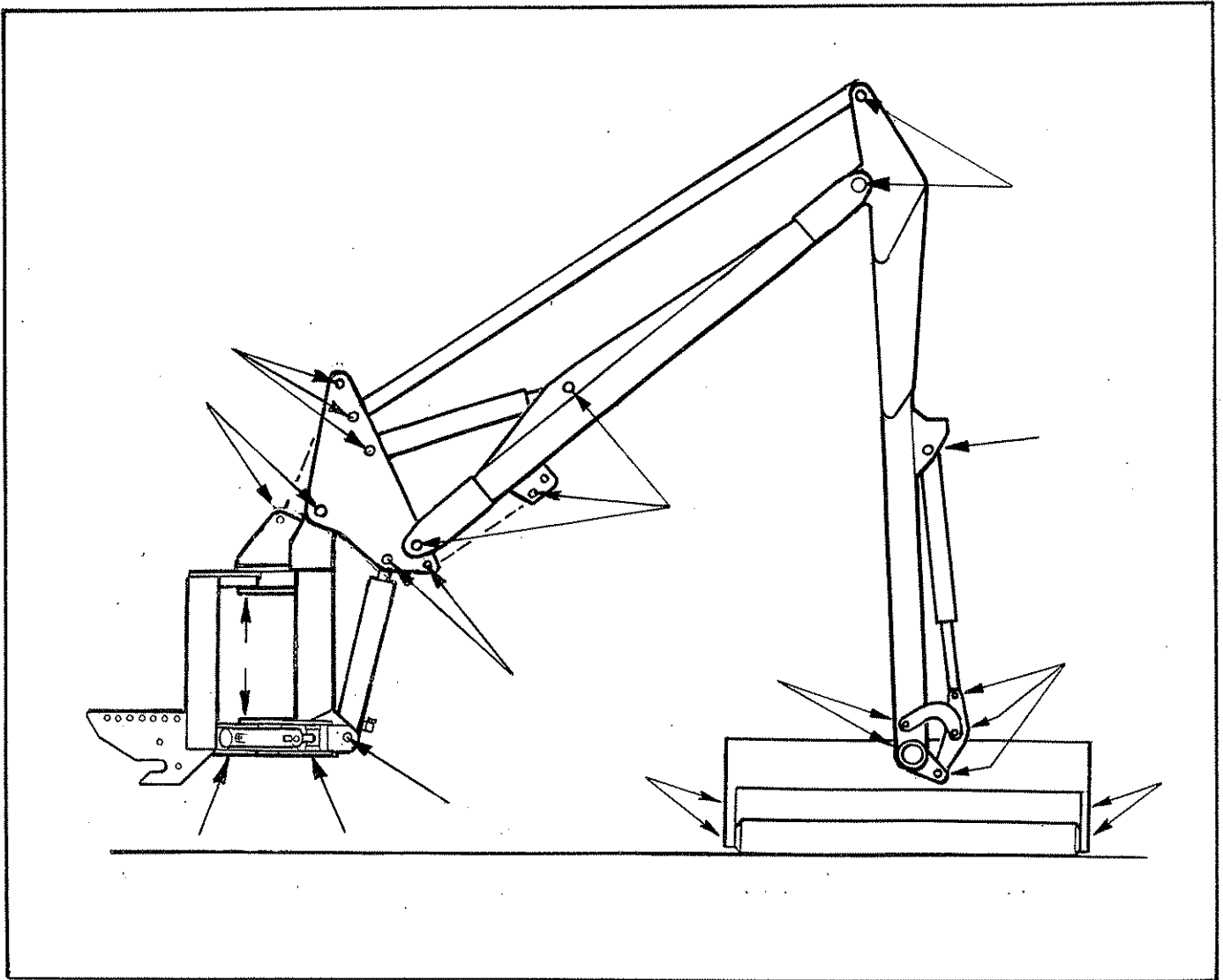

LUBRICATION

General

Grease daily all points shown.

P.T.O. SHAFT

Regularly check the P.T.O. guards for damage and ensure the anti rotation chains are in place and that their anchor points are in good condition.

Do not operate the machine with any damage to guards, replace suspect items immediately.

Lubrication

Lubricate the shaft at the points shown below at the intervals indicated using a general purpose lithium based grease.

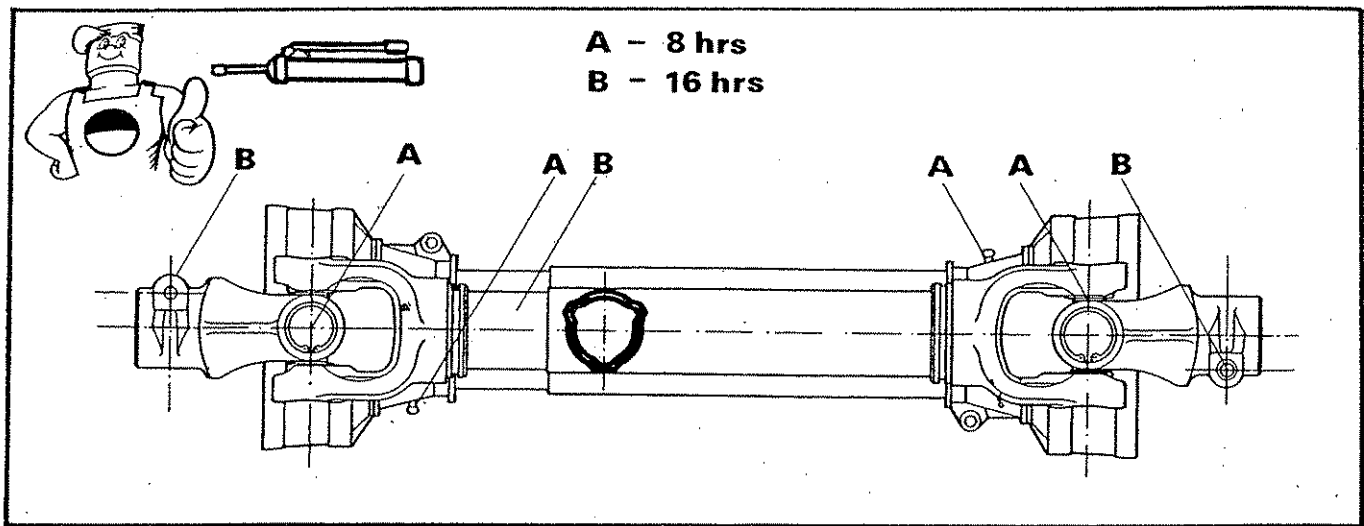

HYDRAULIC SYSTEM

Oil supply

Check the oil level in the reservoir daily.

No fixed time period can be quoted for oil changes as operating conditions and maintenance standards vary so widely. Burnt and scorched oil odours and the oil darkening and thickening are all signs of oxidation and indicate the oil should be changed.

Moisture which results from condensation can become entrapped in the oil and cannot be removed by filtration so that water contamination is progressive.

Contamination can be reduced by:-

- 1) Cleaning around the reservoir cap before removal, and keeping that area clean
- 11) Using clean containers when replenishing the system
- 111) Regular servicing of the filtration system.

Filtration Maintenance

The machine is protected by a 125 micron suction strainer and a low pressure 10 micron full flow return line filter.

- 1) Suction strainer

The strainer is permanently fixed within the reservoir.

Should symptoms of pump cavitation or spongy intermittent operation occur the tank must be drained and flushed out with a suitable cleaning agent eg. clean diesel oil

- 11) Return Line Filter

The elements should be changed after the first 50 hours and thereafter at 500 hour intervals. It is important to note hours worked as if the filter becomes blocked an internal by-pass within the canister will operate and no symptoms of filter malfunction will occur to jog your memory.

HYDRAULIC HOSES

The condition of all hoses should be carefully checked during routine service of the machine. Hoses that have been chafed or damaged on their outer casing should be securely wrapped with waterproof adhesive tape to stop the metal braid from rusting. Hoses that have suffered damage to the metal braid should be changed at the earliest opportunity.

HOSE REPLACEMENT

- a. Replace one hose at a time to avoid the risk of wrong connections.
- b. When the hose is screwed to an additional fitting or union, use a second spanner on the union to avoid breaking both seals.
- c. Do not use jointing compound on the threads.
- d. Avoid twisting the hose. Adjust the hose line to ensure freedom from rubbing or trapping before tightening hose end connections.

Before changing hoses study the installation these are carefully calculated to prevent hose damage during operation. Always replace hoses in exactly the same manner. This is especially important for the flail hoses where they must be crossed, upper to lower, at the dipper and head pivots.

All Hydraulic Hoses (B.S.P.) now fitted to McConnel Power Arm Hedge/Grass Cutters have "Soft Seal" connections on both flail and ram circuit hoses.

Recommended torque settings for nut security are as follows:-

				REF 'O' ring
1/4" BSP	=	24 N.m	or 18 lbf ft	10 000 01
3/8" BSP	=	33 N.m	or 24 lbf ft	10 000 02
1/2" BSP	=	44 N.m	or 35 lbf ft	10 000 03
5/8" BSP	=	58 N.m	or 43 lbf ft	10 000 04
3/4" BSP	=	84 N.m	or 62 lbf ft	10 000 05
1" BSP	=	115 N.m	or 85 lbf ft	10 000 06

For hose unions (B.S.P.) fitted in conjunction with bonded seals the recommended torque settings are as follows:-

1/4" BSP	=	34 N.m	or 25 lbf ft
3/8" BSP	=	75 N.m	or 55 lbf ft
1/2" BSP	=	102 N.m	or 75 lbf ft
5/8" BSP	=	122 N.m	or 90 lbf ft
3/4" BSP	=	183 N.m	or 135 lbf ft
1" BSP	=	203 N.m	or 150 lbf ft

SAFETY NOTE

Soft Seal hose connections are capable of holding pressure when the nut is only "finger tight". It is therefore recommended that when dismantling the hose is manually flexed, to relieve any residual pressure, with the retaining nut slackened prior to complete disassembly.

CABLES *

The cables operate on a push/pull system with the spool centering springs always returning the spool to the neutral position when the handle is released.

Care should be taken during installation and operation to ensure that the cables are not trapped or kinked. Any abrasion or damage to the outer casing should be sealed with plastic insulation tape to avoid moisture penetrating.

No routine adjustment of the cables are necessary as they do not stretch. The threaded collar is correctly adjusted when the lever is in a vertical position in its housing allowing an equal amount of travel in either direction.

CAUTION On no account should any attempt be made to lubricate the cables which are assembled with a special lubricant during manufacture.

NOTE Take care to ascertain the correct cable connections on both the control unit and the valve in the event of cable replacement.

P.T.O. GEARBOX

Refill with 0.5l. of SAE 80 or ISO 100 at the following intervals:

1. After 50 hours
2. Thereafter at annual or 500 hour intervals whichever occurs earliest.

HOSE CONNECTIONS

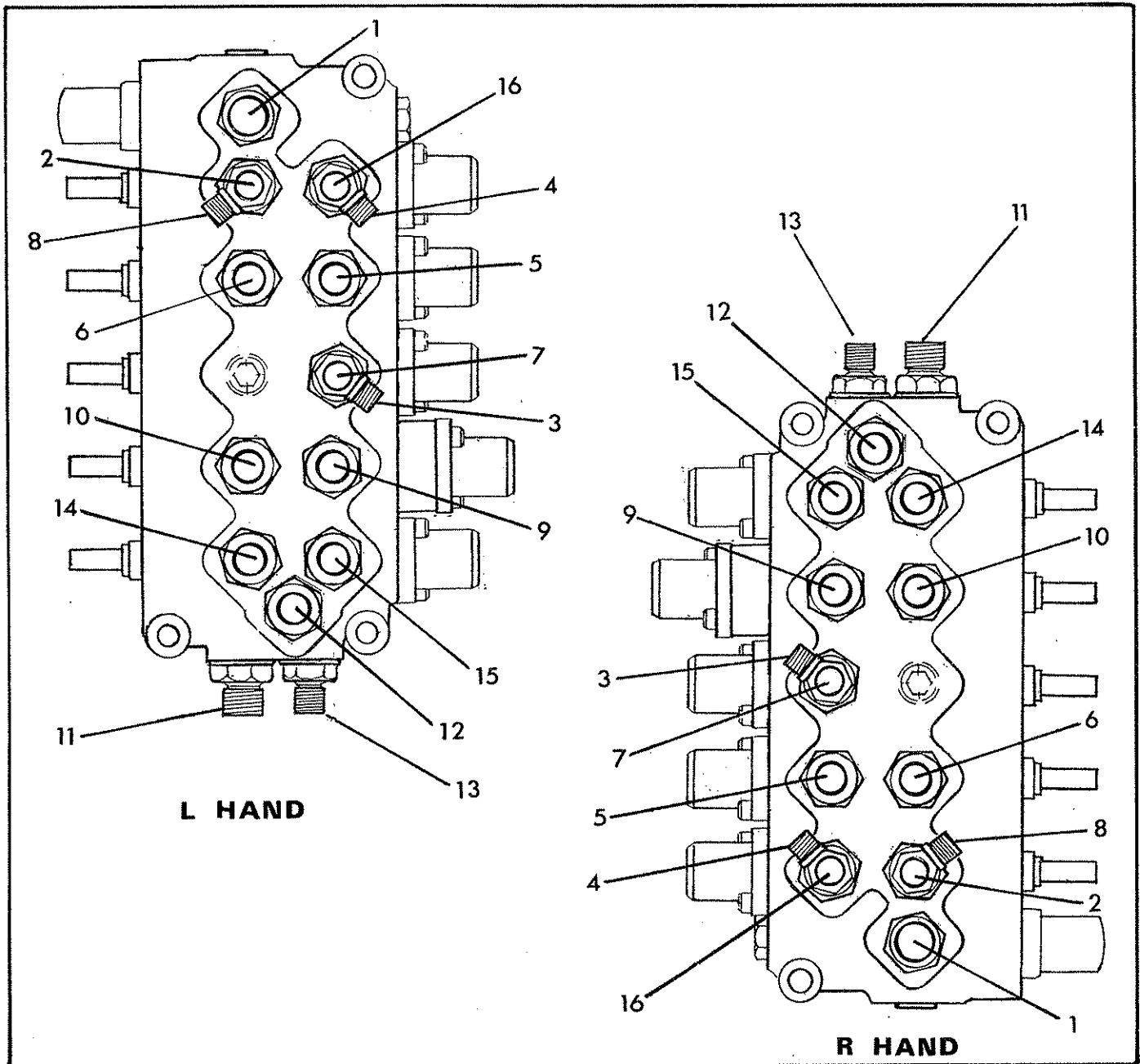

MAIN VALVE - Cable control models

- | | |
|---------------------|---------------------------|
| 1. Supply from pump | 9. Angle gland |
| 2. Slew base | 10. Angle base |
| 3. Connection 13 | 11. Return to Rotor valve |
| 4. Connection 15 | 12. Lift gland |
| 5. Reach gland | 13. Connection 3 |
| 6. Reach base | 14. Connection 8 |
| 7. Lift base | 15. Connection 4 |
| 8. Connection 14 | 16. Slew gland |

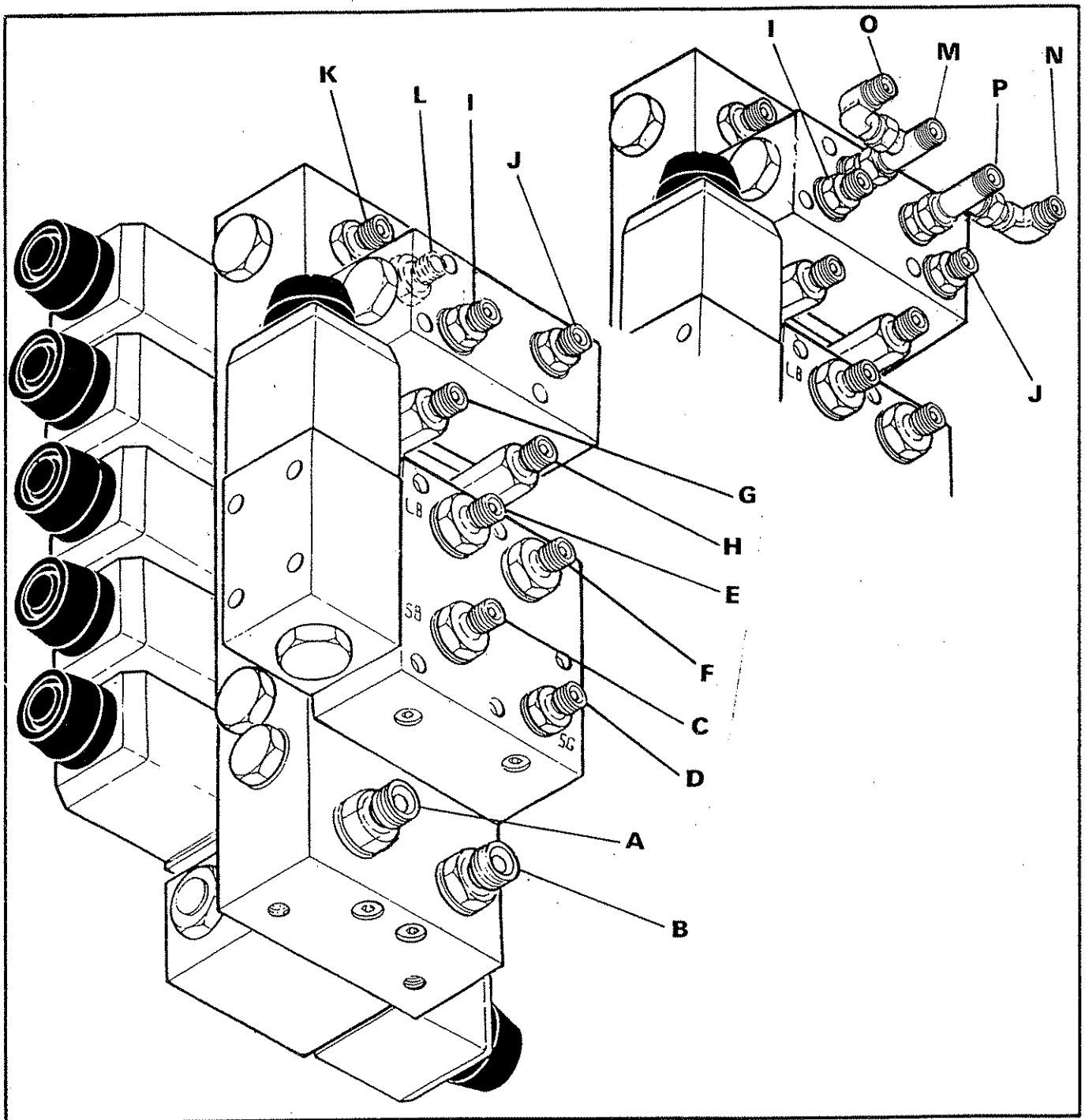

MAIN VALVE - ELECTRIC

- | | |
|-----------------------------|-----------------------------------|
| A - Supply | B - Return to Rotor control valve |
| C - Slew base | D - Slew gland |
| E - Lift base | F - Lift gland |
| G - Midcut base (if fitted) | H - Midcut gland (if fitted) |
| I - Angle base | J - Angle gland |
| K - Reach base | L - Reach gland |
| M - Lift compensator base | N - Lift compensator gland |
| O - Reach Compensator base | P - Reach Compensator gland |

ROTOR CONTROL VALVE - All totally independent machines

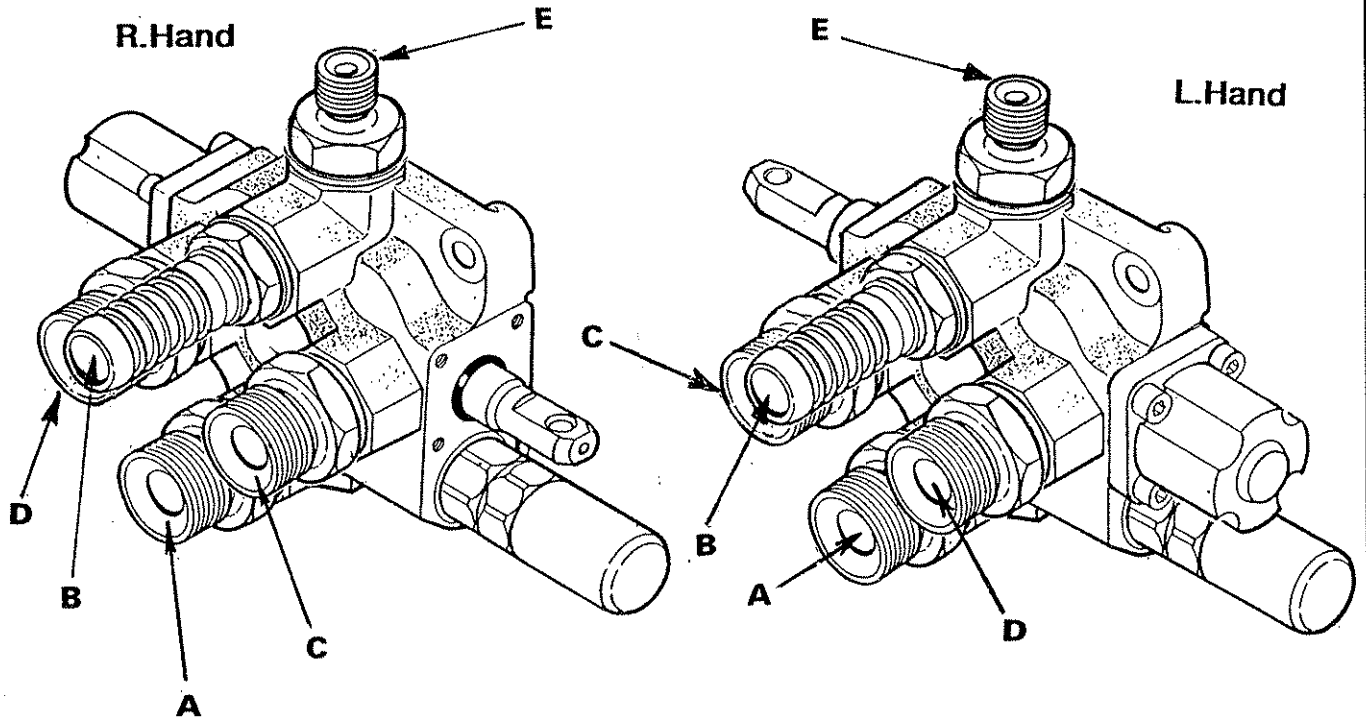

ROTOR RELIEF VALVE - All semi independent machines

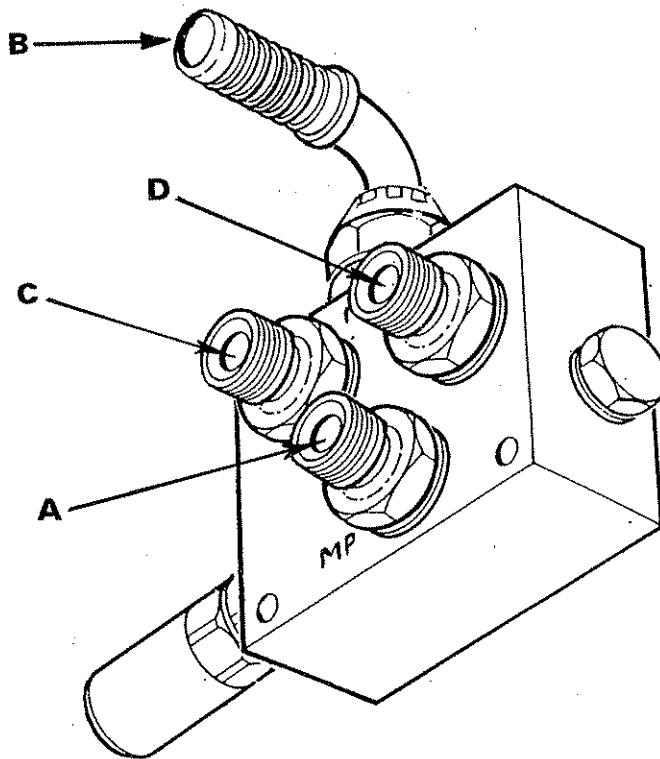

A - Supply from pump

B - Return to tank

C - Motor upper

D - Motor lower

E - Return from main valve.

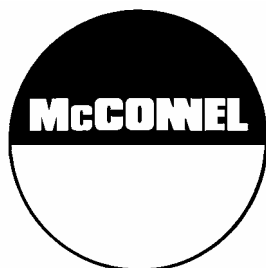

McConnel Limited, Temeside Works, Ludlow, Shropshire SY8 1JL. England.
Telephone: 01584 873131. Facsimile: 01584 876463. www.mcconnel.com