

Publication 409
August 2001
Part No. 41570.10



PA 32

HEDGE/GRASS TRIMMER

Operator Manual



IMPORTANT

VERIFICATION OF WARRANTY REGISTRATION



DEALER WARRANTY INFORMATION & REGISTRATION VERIFICATION

It is imperative that the selling dealer registers this machine with McConnel Limited before delivery to the end user – failure to do so may affect the validity of the machine warranty.

To register machines go to the McConnel Limited web site at www.mcconnel.com, log onto 'Dealer Inside' and select the 'Machine Registration button' which can be found in the Service Section of the site. Confirm to the customer that the machine has been registered in the section below.

Should you experience any problems registering a machine in this manner please contact the McConnel Service Department on 01584 875848.

Registration Verification

Dealer Name:
Dealer Address:
Customer Name:
Date of Warranty Registration:/...../..... Dealer Signature:

NOTE TO CUSTOMER / OWNER

Please ensure that the above section above has been completed and signed by the selling dealer to verify that your machine has been registered with McConnel Limited.

IMPORTANT: During the initial 'bedding in' period of a new machine it is the customer's responsibility to regularly inspect all nuts, bolts and hose connections for tightness and re-tighten if required. New hydraulic connections occasionally weep small amounts of oil as the seals and joints settle in – where this occurs it can be cured by re-tightening the connection – *refer to torque settings chart below*. The tasks stated above should be performed on an hourly basis during the first day of work and at least daily thereafter as part of the machines general maintenance procedure.

TORQUE SETTINGS FOR HYDRAULIC FITTINGS

HYDRAULIC HOSE ENDS		
BSP	Setting	Metric
1/4"	18 Nm	19 mm
3/8"	31 Nm	22 mm
1/2"	49 Nm	27 mm
5/8"	60 Nm	30 mm
3/4"	80 Nm	32 mm
1"	125 Nm	41 mm
1.1/4"	190 Nm	50 mm
1.1/2"	250 Nm	55 mm
2"	420 Nm	70 mm

PORT ADAPTORS WITH BONDED SEALS		
BSP	Setting	Metric
1/4"	34 Nm	19 mm
3/8"	47 Nm	22 mm
1/2"	102 Nm	27 mm
5/8"	122 Nm	30 mm
3/4"	149 Nm	32 mm
1"	203 Nm	41 mm
1.1/4"	305 Nm	50 mm
1.1/2"	305 Nm	55 mm
2"	400 Nm	70 mm

WARRANTY POLICY

WARRANTY REGISTRATION

All machines must be registered, by the selling dealer with McConnell Ltd, before delivery to the end user. On receipt of the goods it is the buyer's responsibility to check that the Verification of Warranty Registration in the Operator's Manual has been completed by the selling dealer.

1. LIMITED WARRANTIES

- 1.01. All machines supplied by McConnell Limited are warranted to be free from defects in material and workmanship from the date of sale to the original purchaser for a period of 12 months, unless a different period is specified.
- 1.02. All spare parts supplied by McConnell Limited are warranted to be free from defects in material and workmanship from the date of sale to the original purchaser for a period of 6 months.
- 1.03. The manufacturer will replace or repair for the purchaser any part or parts found, upon examination at its factory, to be defective under normal use and service due to defects in material or workmanship. Returned parts must be complete and unexamined.
- 1.04. This warranty does not apply to any part of the goods, which has been subjected to improper or abnormal use, negligence, alteration, modification, fitment of non-genuine parts, accident damage, or damage resulting from contact with overhead power lines, damage caused by foreign objects (e.g. stones, iron, material other than vegetation), failure due to lack of maintenance, use of incorrect oil or lubricants, contamination of the oil, or which has served its normal life. This warranty does not apply to any expendable items such as blades, flails, flap kits, skids, soil engaging parts, shields, guards, wear pads or pneumatic tyres.
- 1.05. Temporary repairs and consequential loss - i.e. oil, downtime and associated parts are specifically excluded from the warranty.
- 1.06. Warranty on hoses is limited to 12 months and does not include hoses which have suffered external damage. Only complete hoses may be returned under warranty, any which have been cut or repaired will be rejected.
- 1.07. Machines must be repaired immediately a problem arises. Continued use of the machine after a problem has occurred can result in further component failures, for which McConnell Ltd cannot be held liable, and may have safety implications.
- 1.08. Except as provided herein, no employee, agent, dealer or other person is authorised to give any warranties of any nature on behalf of McConnell Ltd.
- 1.09. For machine warranty periods in excess of 12 months the following additional exclusions shall apply:
 - 1) Hoses, external seals, exposed pipes and hydraulic tank breathers.
 - 2) Filters.
 - 3) Rubber mountings.
 - 4) External electric wiring.

N.B. Warranty cover will be invalid if any non-genuine parts have been fitted or used. Use of non-genuine parts may seriously affect the machine's performance and safety. McConnell Ltd. cannot be held responsible for any failures or safety implications that arise due to the use of non-genuine parts.

2. REMEDIES AND PROCEDURES

- 2.01. The warranty is not effective unless the Selling Dealer registers the machine, via the McConnel web site and confirms the registration to the purchaser by completing the Verification of Warranty Registration in the operator's manual.
- 2.02. Any fault must be reported to an authorised McConnel dealer as soon as it occurs. Continued use of a machine, after a fault has occurred, can result in further component failure for which McConnel Ltd cannot be held liable.
- 2.03. Repairs should be undertaken within two days of the failure. Claims submitted for repairs undertaken more than 2 weeks after a failure has occurred, or 2 days after the parts were supplied will be rejected, unless the delay has been authorised by McConnel Ltd.
- 2.04. All claims must be submitted, by an authorised McConnel Service Dealer, within 30 days of the date of repair.
- 2.05. Following examination of the claim and parts the manufacture will pay, at their discretion, for any valid claim the cost of any parts and an appropriate labour allowance if applicable.
- 2.06. The submission of a claim is not a guarantee of payment.
- 2.07. Any decision reached by McConnel Ltd. is final.

3. LIMITATION OF LIABILITY

- 3.01. The manufacturer disclaims any express (except as set forth herein) and implied warranties with respect to the goods including, but not limited to, merchantability and fitness for a particular purpose.
- 3.02. The manufacturer makes no warranty as to the design, capability, capacity or suitability for use of the goods.
- 3.03. Except as provided herein, the manufacturer shall have no liability or responsibility to the purchaser or any other person or entity with respect to any liability, loss, or damage caused or alleged to be caused directly or indirectly by the goods including, but not limited to, any indirect, special, consequential, or incidental damages resulting from the use or operation of the goods or any breach of this warranty. Notwithstanding the above limitations and warranties, the manufacturer's liability hereunder for damages incurred by the purchaser or others shall not exceed the price of the goods.
- 3.04. No action arising out of any claimed breach of this warranty or transactions under this warranty may be brought more than one (1) year after the cause of the action has occurred.

4. MISCELLANEOUS

- 4.01. The manufacturer may waive compliance with any of the terms of this limited warranty, but no waiver of any terms shall be deemed to be a waiver of any other term.
- 4.02. If any provision of this limited warranty shall violate any applicable law and is held to be unenforceable, then the invalidity of such provision shall not invalidate any other provisions herein.
- 4.03. Applicable law may provide rights and benefits to the purchaser in addition to those provided herein.

EC DECLARATION OF CONFORMITY

*Conforming to EEC Machinery Directive 98/37/EC**

We,

McCONNEL LIMITED,

Temeside Works, Ludlow, Shropshire SY8 1JL.

Declare under our sole responsibility that:

The product (type) ..Tractor Mounted Hedge Cutter / Trimmer.....

.....

Product Code ..PA32.....

Serial No. & Date Type

Manufactured by the above company/*

.....

(* insert business name and full address if not stated above)

Complies with the required provisions of the Machinery Directive 98/37/EC, * previously Directive 89/392/EEC as amended by Directives 91/368/EEC, 93/44/EEC and 93/68/EEC.

The machinery directive is supported by;

- BS EN ISO 12100:2003 Safety of Machinery. This standard is made up of two parts; Part 1 Terminology, methodology, Part 2 Technical Specifications.
- BS EN 1050 Safety of machinery - Principles of risk assessment.
- and other national standards associated with its design and construction as listed in the Technical File.

The Machinery Directive is fully implemented into UK law by means of the Supply of Machinery (Safety) Regulations 1992 (SI 1992/3073) as amended by The Supply of Machinery (Safety) (Amendment) Regulations 1994 (SI 1994/2063).

Signed

on behalf of McCONNEL LIMITED

Responsible Person

Status: Chief Design Engineer

Date: May 2005

EC DECLARATION OF CONFORMITY

*Conforming to EEC Machinery Directive 98/37/EC**

We,

McCONNEL LIMITED,

Temeside Works, Ludlow, Shropshire SY8 1JL.

Declare under our sole responsibility that:

The product (type) ..Hydraulic Arm Mounted Flailhead.....

.....

Product Code ..BD12, BD16, F110, F112, F115, F012, F016.....

Serial No. & Date Type

Manufactured by the above company/*

.....

(* insert business name and full address if not stated above)

Complies with the required provisions of the Machinery Directive 98/37/EC, * previously Directive 89/392/EEC as amended by Directives 91/368/EEC, 93/44/EEC and 93/68/EEC.

The machinery directive is supported by;

- BS EN ISO 12100:2003 Safety of Machinery. This standard is made up of two parts; Part 1 Terminology, methodology, Part 2 Technical Specifications.
- BS EN 1050 Safety of machinery - Principles of risk assessment.
- and other national standards associated with its design and construction as listed in the Technical File.

The Machinery Directive is fully implemented into UK law by means of the Supply of Machinery (Safety) Regulations 1992 (SI 1992/3073) as amended by The Supply of Machinery (Safety) (Amendment) Regulations 1994 (SI 1994/2063).

Signed

on behalf of McCONNEL LIMITED

Responsible Person

Status: Chief Design Engineer

Date: May 2005

READ THE BOOK FIRST

It might save hours and pounds later !

When ordering spare parts always quote

- ***The Machine Type***
- ***The Machine Serial Number***
- ***The Part Number***

Factory re-built service exchange units of the major hydraulic components are available from your Dealer

NOISE

The equivalent daily personal noise exposure from this machine, measured at the operators' ear, is within the range 78 – 85 DB.

These figures apply to a normal distribution of use where the noise fluctuates between zero and maximum. The figures assume that the machine is fitted to a tractor with a quiet cab with the windows closed in a generally open environment. We recommend that the windows are kept closed.

With the cab rear window open the equivalent daily personal noise exposure will increase to a figure within the range 82 – 88 DB.

At equivalent daily noise exposure levels of between 85 and 90 DB, ear protection is recommended, it should be used if any window is left open.

LIST OF CONTENTS

INTRODUCTION	Page 1
GENERAL INFORMATION	Page 2
SAFETY PRECAUTIONS	Page 3
FITTING AND REMOVAL	Page 7
TRACTOR SELECTION	Page 7
Linkage requirements.....	Page 7
Linkage isolation.....	Page 7
Check chains/stabilisers.....	Page 7
Tractor relief valve.....	Page 7
Tractor hydraulic flow rates.....	Page 7
PTO shaft	Page 7
Stability	Page 7
TRACTOR PREPARATION	Page 8
Fitting operator guard.....	Page 8
Wheel width.....	Page 8
Ballast weight.....	Page 8
Lift links.....	Page 8
Closed centre conversion kit.....	Page 9
OIL REQUIREMENTS	Page 10
ATTACHMENT TO TRACTOR	Page 11
FITTING CONTROL UNIT IN CAB	Page 16
RUNNING UP PROCEDURE	Page 17
REMOVAL FROM TRACTOR	Page 18
STORAGE	Page 18
OPERATION	Page 19
LIMITATION	Page 19
OPERATOR GUARD	Page 19
PREPARATION	Page 19
MACHINE CONTROLS	Page 20
Arm Controls	Page 20
Rotor control - <i>flail head only</i>	Page 21
Mini proportional controls.....	21a,b&c
TRANSPORT POSITION	Page 22
ENGAGING DRIVE	Page 22
OPERATING SPEED	Page 23
FORWARD SPEED	Page 23
HIGHWAY WORKING	Page 23
WORKING PRACTISES	Page 24
BREAKAWAY	Page 24
WORKING CLOSE IN TO TRACTOR	Page 24
WIRE TRAP	Page 24
REMOVING WIRE FROM ROTOR	Page 25
UNCLOGGING CUTTERBAR	Page 25
OVERHEAD OBSTRUCTIONS	Page 25
HIGH VOLTAGE CABLES	Page 25
HEDGE CUTTING PROCEDURE	Page 26
Preliminary precautions.....	Page 26
Upward cutting	Page 26

Downward cutting.....	Page 26
Reversing rotation <i>T. i. machines only</i>	Page 26
Reversing rotation <i>S. i. machines only</i>	Page 26
CUTTING SEQUENCE.....	Page 27
GRASS CUTTING	Page 28
ROLLER POSITIONS.....	Page 28
LIFT FLOAT KIT (<i>optional extra</i>).....	Page 29

MAINTENANCE	Page 30
LUBRICATION.....	Page 30
General.....	Page 30
P. T. O. shaft.....	Page 30
HYDRAULIC SYSTEM.....	Page 31
P.T.O. GEARBOX.....	Page 31
CABLES.....	Page 32
HYDRAULIC HOSES.....	Page 32
FLAIL HEAD.....	Page 33
CUTTERBAR ADJUSTMENT.....	Page 34
CUTTERBAR SHARPENING.....	Page 35
HOSE CONNECTIONS.....	Page 36



Notes

A series of horizontal dotted lines for writing notes, spanning the width of the page.

INTRODUCTION

PA32 - *all models*

- **Linkage mounted**
- **Right of left hand cutting**
- **Operator guard**
- **Hydraulic breakaway return**
- **65 litre/14 gallon hydraulic reservoir**
- **Cable controls**

PA32 *Si (semi independent models)*

- **Semi independent hydraulics - tractor power for arm movements,
- P.T.O. pump for rotor or cutterbar.**
- **Rotor or cutterbar engagement by tractors P.T.O. lever.**
- **Choice of 1.5m cutterbar or 0.9m flailhead.**
- **20 Hp single pump hydraulic system.**

PA32 *Ti (totally independent models)*

- **Totally independent hydraulics**
- **0.9m flail only**
- **Independent reversible Rotor on/off valve.**
- **20 Hp tandem pump hydraulic system.**
- **Option of lift float.**

GENERAL INFORMATION

Read this manual before fitting or operating the machine. Whenever any doubt exists contact your dealer or the McConnell Service Department for assistance.

Use only McConnell Genuine spare parts on McConnell equipment and machines.

DEFINITIONS:The following definitions apply throughout this manual:

WARNING

An operating procedure, technique etc., which can result in personal injury or loss of life if not observed carefully.

CAUTION

An operating procedure, technique etc., which can result in the damage of either machine or equipment if not observed carefully.

NOTE

An operating procedure, technique etc., which is considered essential to emphasise.

LEFT AND RIGHT HAND

This term is applicable to the machine when fitted to the tractor and viewed from the rear. This also applies to tractor references.

Record the serial number of your machine on this page and always quote this number when ordering spares. Whenever information concerning the machine is requested remember to also state the type of tractor to which it is fitted.

MACHINE
SERIAL
NUMBER

INSTALLATION
DATE

MODEL
DETAILS

DEALERS
NAME

DEALERS
TELEPHONE
NUMBER



SAFETY INFORMATION

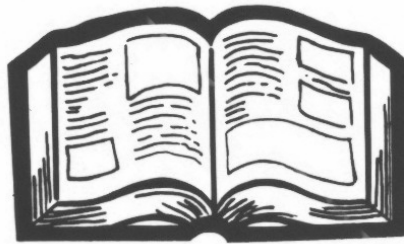

This machine has the potential to be extremely dangerous, in the wrong hands it can kill or maim. It is therefore imperative that both owner, and operator of this machine, read and understand the following section to ensure that they are fully aware of the dangers that do, or may exist, and their responsibilities surrounding the use and operation of the machine. The operator of this machine is responsible not only for their own safety but equally for the safety of others who may come into the close proximity of the machine, as the owner you are responsible for both.

When the machine is not in use the cutting head should be lowered to rest on the ground. In the event of a fault being detected with the machine's operation it should be stopped immediately and not used again until the fault has been corrected by a qualified technician.

POTENTIAL SIGNIFICANT DANGERS ASSOCIATED WITH THE USE OF THIS MACHINE:

- ▲ *Being hit by debris thrown by rotating components.*
- ▲ *Being hit by machine parts ejected through damage during use.*
- ▲ *Being caught on a rotating power take-off (PTO) shaft.*
- ▲ *Being caught in other moving parts i.e.: belts, pulleys and cutting heads.*
- ▲ *Electrocution from Overhead Power Lines (by contact with or 'flashover' from).*
- ▲ *Being hit by cutting heads or machine arms as they move.*
- ▲ *Becoming trapped between tractor and machine when hitching or unhitching.*
- ▲ *Tractor overbalancing when machine arm is extended.*
- ▲ *Injection of high-pressure oil from hydraulic hoses or couplings.*
- ▲ *Machine overbalancing when freestanding (out of use).*
- ▲ *Road traffic accidents due to collision or debris on the road.*

BEFORE USING THIS MACHINE YOU MUST:

- ▲ *Ensure you read all sections of the operator handbook.*
- ▲ *Ensure the operator is, or has been, properly trained to use the machine.*
- ▲ *Ensure the operator has been issued with and reads the operator handbook.*
- ▲ *Ensure the operator understands and follows the instructions in operator handbook.*
- ▲ *Ensure the tractor front, rear and side(s) are fitted with metal mesh or polycarbonate guards of suitable size and strength to protect the operator against thrown debris or parts.*
- ▲ *Ensure tractor guards are fitted correctly, are undamaged and kept properly maintained.*
- ▲ *Ensure that all machine guards are in position, are undamaged, and are kept maintained in accordance with the manufacturer's recommendations.*
- ▲ *Ensure flails and their fixings are of a type recommended by the manufacturer, are securely attached and that none are missing or damaged.*
- ▲ *Ensure hydraulic pipes are carefully and correctly routed to avoid damage by chaffing, stretching or pinching and that they are held in place with the correct fittings.*
- ▲ *Always follow the manufacturer's instructions for attachment and removal of the machine from the tractor.*
- ▲ *Check that the machine fittings and couplings are in good condition.*
- ▲ *Ensure the tractor meets the minimum weight recommendations of the machine's manufacturer and that ballast is used as necessary.*
- ▲ *Always inspect the work area thoroughly before starting to note obstacles and remove wire, bottles, cans and other debris.*
- ▲ *Use clear suitably sized warning signs to alert others to the nature of the machine working within that area. Signs should be placed at both ends of the work site. (It is recommended that signs used are of a size and type specified by the Department of Transport and positioned in accordance with their, and the Local Highways Authority, guidelines).*
- ▲ *Ensure the operator is protected from noise. Ear defenders should be worn and tractor cab doors and windows must be kept closed. Machine controls should be routed through proprietary openings in the cab to enable all windows to be shut fully.*
- ▲ *Always work at a safe speed taking account of the conditions i.e.: terrain, highway proximity and obstacles around and above the machine. Extra special attention should be applied to Overhead Power Lines. Some of our machines are capable of reach in excess of 8 metres (26 feet) this means they have the potential to well exceed, by possibly 3 metres (9' 9"), the lowest legal minimum height of 5.2 metres from the ground for 11,000 and 33,000 volt power lines. It cannot be stressed enough the dangers that surround this capability, it is therefore vital that the operator is fully aware of the maximum height and reach of the machine, and that they are fully conversant with all aspects regarding the safe minimum distances that apply when working with machines in close proximity to Power Lines. (Further information on this subject can be obtained from the Health & Safety Executive or your Local Power Company).*

- ▲ *Always disengage the machine, kill the tractor engine, remove and pocket the key before dismounting for any reason.*
- ▲ *Always clear up all debris left at the work area, it may cause hazard to others.*
- ▲ *Always ensure when you remove your machine from the tractor that it is left in a safe and stable position using the stands and props provided and secured if necessary.*

WHEN NOT TO USE THIS MACHINE:

- ▲ *Never attempt to use this machine if you have not been trained to do so.*
- ▲ *Never use a machine until you have read and understood the operator handbook, are familiar with it, and practiced the controls.*
- ▲ *Never use a machine that is poorly maintained.*
- ▲ *Never use a machine if guards are missing or damaged.*
- ▲ *Never use a machine on which the hydraulic system shows signs of wear or damage.*
- ▲ *Never fit, or use, a machine on a tractor that does not meet the manufacturer's minimum specification level.*
- ▲ *Never use a machine fitted to a tractor that does not have suitable front, rear and side(s) cab guarding made of metal mesh or polycarbonate.*
- ▲ *Never use the machine if the tractor cab guarding is damaged, deteriorating or badly fitted.*
- ▲ *Never turn a machine cutting head to an angle that causes debris to be ejected towards the cab.*
- ▲ *Never start or continue to work a machine if people are nearby or approaching - Stop and wait until they are at a safe distance before continuing. WARNING: Some Cutting Heads may continue to 'freewheel' for up to 40 seconds after being stopped.*
- ▲ *Never attempt to use a machine on materials in excess of its capability.*
- ▲ *Never use a machine to perform a task it has not been designed to do.*
- ▲ *Never operate the tractor or machine controls from any position other than from the driving seat, especially whilst hitching or unhitching the machine.*
- ▲ *Never carry out maintenance of a machine or a tractor whilst the engine is running – the engine should be switched off, the key removed and pocketed.*
- ▲ *Never leave a machine unattended in a raised position – it should be lowered to the ground in a safe position on a level firm site.*
- ▲ *Never leave a tractor with the key in or the engine running.*
- ▲ *Never carry out maintenance on any part or component of a machine that is raised unless that part or component has been properly substantially braced or supported.*
- ▲ *Never attempt to detect a hydraulic leak with your hand – use a piece of cardboard.*
- ▲ *Never allow children near to, or play on, a tractor or machine under any circumstances.*

ADDITIONAL SAFETY ADVICE

Training

Operators need to be competent and fully capable of operating this machine in a safe and efficient way prior to attempting to use it in any public place. We advise therefore that the prospective operator make use of relevant training courses available such as those run by the Agricultural Training Board, Agricultural Colleges, Dealers and McConnel.

Working in Public Places

When working in public places such as roadsides, consideration should be paid to others in the vicinity. Stop the machine immediately when pedestrians, cyclists and horse riders etc. pass. Restart only when they are at a distance that causes no risk to their safety.

Warning Signs

It is advisable that any working area be covered by suitable warning signs and statutory in public places. Signs should be highly visible and well placed in order to give clear advanced warning of the hazard. Contact the Department of Transport or your Local Highways Authority to obtain detailed information on this subject. The latter should be contacted prior to working on the public highway advising them of the time and location of the intended work asking what is required by way of signs and procedure. – ‘*Non-authorised placement of road signs may create offences under the Highways Act*’.

Suggested Warning Signs Required

“Road works ahead” warning sign with a supplementary **“Hedge cutting”** plate. **“For 1 mile”** or appropriate shorter distance may be added to the plate.

“Road narrows” warning sign with supplementary **“Single file traffic”** plate.

White on blue **“Keep right”** (*) arrow sign on rear of machine.

* Note – this applies to UK Market machines where traffic passes to the right of a machine working in the same direction as the traffic flow. The direction, use and colour of the arrow sign will depend on the country of use and the Local Highway Authorities regulations in the locality.

Use of Warning Signs

- ▲ On two-way roads one set of signs is needed facing traffic in each direction.
- ▲ Work should be within 1 mile of the signs.
- ▲ Work only when visibility is good and at times of low risk e.g.: NOT during ‘rush-hour’.
- ▲ Vehicles should have an amber-flashing beacon.
- ▲ Ideally, vehicles should be conspicuously coloured.
- ▲ Debris should be removed from the road and path as soon as practicable, and at regular intervals, wearing high visibility clothing and before removing the hazard warning signs.
- ▲ Collect all road signs promptly when the job is completed.

Although the information given here covers a wide range of safety subjects, it is impossible to predict every eventuality that can occur under differing circumstances whilst operating this machine. No advice given here can replace ‘good common sense’ and ‘total awareness’ at all times, but will go a long way towards the safe use of your McConnel machine.

FITTING

TRACTOR SELECTION

Linkage requirements

Tractor must be equipped with Category 1 Linkage.

Linkage isolation

A linkage isolation facility is necessary for Si models **only**.

Check chains/stabilisers

Check chains or stabiliser **bars** must be fitted and tightened.

Tractor relief valve

For Si models only tractor relief valve must be set above 160 Bar (2300 PSI).

Tractor hydraulic flow rate

Hydraulic flow rates are not crucial for Si models

PTO shaft

Tractor must be equipped with live drive independent PTO shaft to enable forward movement to be halted while the flail head continues to operate.

Horse power requirements.

25HP min PA32 with cutterbar

30HP min PA32 with flail head

Stability requirements

PA32 with cutterbar: 750kg min tractor weight including front ballast.

PA32 with flail head: 1300kg min tractor weight including front ballast and with a minimum outside tyre width of 1.4m.

TRACTOR PREPARATION

Fitting Tractor Guard: Use tractor with safety glass windows if possible and fit Operator guard (*part no. 73 13 324*) using the hooks provided. Shape mesh to cover all vulnerable areas. Remember the driver must be looking through mesh and/or polycarbonate glazing when viewing the flail head in any working position - unless the tractor/cab manufacturer

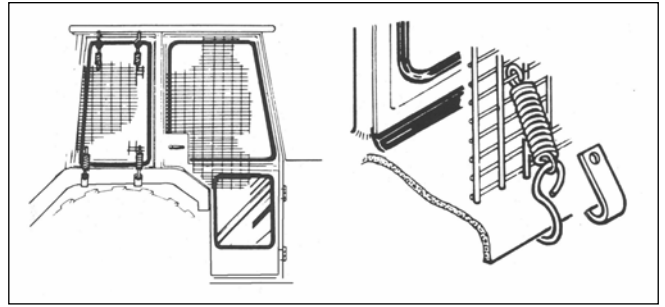

can demonstrate that the penetration resistance is equivalent to, or higher than, that provided by mesh/polycarbonate glazing. If the tractor has a roll bar only, a frame must be made to carry both mesh and polycarbonate glazing.

Wheel Width: Set wheel widths as wide as possible.

Lift Links: Adjust lift links until they are equal length.

Tractor Ballast: It is imperative when attaching 'third-party' equipment to a tractor that the maximum possible stability of the machine and tractor combination is achieved – this can be accomplished by the utilisation of 'ballast' in order to counter-balance the additional equipment added.

Front weights may be required to place 15% of total outfit weight on the front axle for stable transport on the road and to reduce 'crabbing' due to the drag of the cutting unit when working on the ground.

Rear weights may be required to maintain a reasonable amount of rear axle load on the opposite wheel from the arms when in work; for normal off-ground work i.e. hedge cutting this should be 20% of rear axle weight or more for adequate control, and for ground work i.e. verge mowing with experienced operators, this can be reduced to 10%.

All factors must be addressed in order to match the type and nature of the equipment added to the circumstances under which it will be used – in the instance of Power Arm Hedgecutters it must be remembered that the machines centre of gravity during work will be constantly moving and will differ from that during transport mode, therefore balance becomes critical.

Factors that effect stability:

- *Centre of gravity of the tractor/machine combination.*
- *Geometric conditions, e.g. position of the cutting head and ballast.*
- *Weight, track width and wheelbase of the tractor.*
- *Acceleration, braking, turning and the relative position of the cutting head during these operations.*
- *Ground conditions, e.g. slope, grip, load capability of the soil/surface.*
- *Rigidity of implement mounting.*

Suggestions to increase stability:

- *Increasing rear wheel track; a tractor with a wider wheel track is more stable.*
- *Ballasting the wheel; it is preferable to use external weights but liquid can be added to around 75% of the tyre volume – water with anti-freeze or the heavier Calcium Chloride alternative can be used.*
- *Addition of weights – care should be taken in selecting the location of the weights to ensure they are added to a position that offers the greatest advantage.*
- *Front axle locking; a ram can be used to 'lock' the front axle in work only – locking the axle moves the 'balance line' and can be used to transfer weight to the front axle from the rear (check with tractor manufacturer).*

The advice above is offered as a guide for stability only and is not a guide to tractor strength - it is therefore recommended that you consult your tractor manufacturer or local dealer to obtain specific advise on this subject, additionally advice should be sought from a tyre specialist with regard to tyre pressures and ratings suitable for the type and nature of the machine you intend to fit.

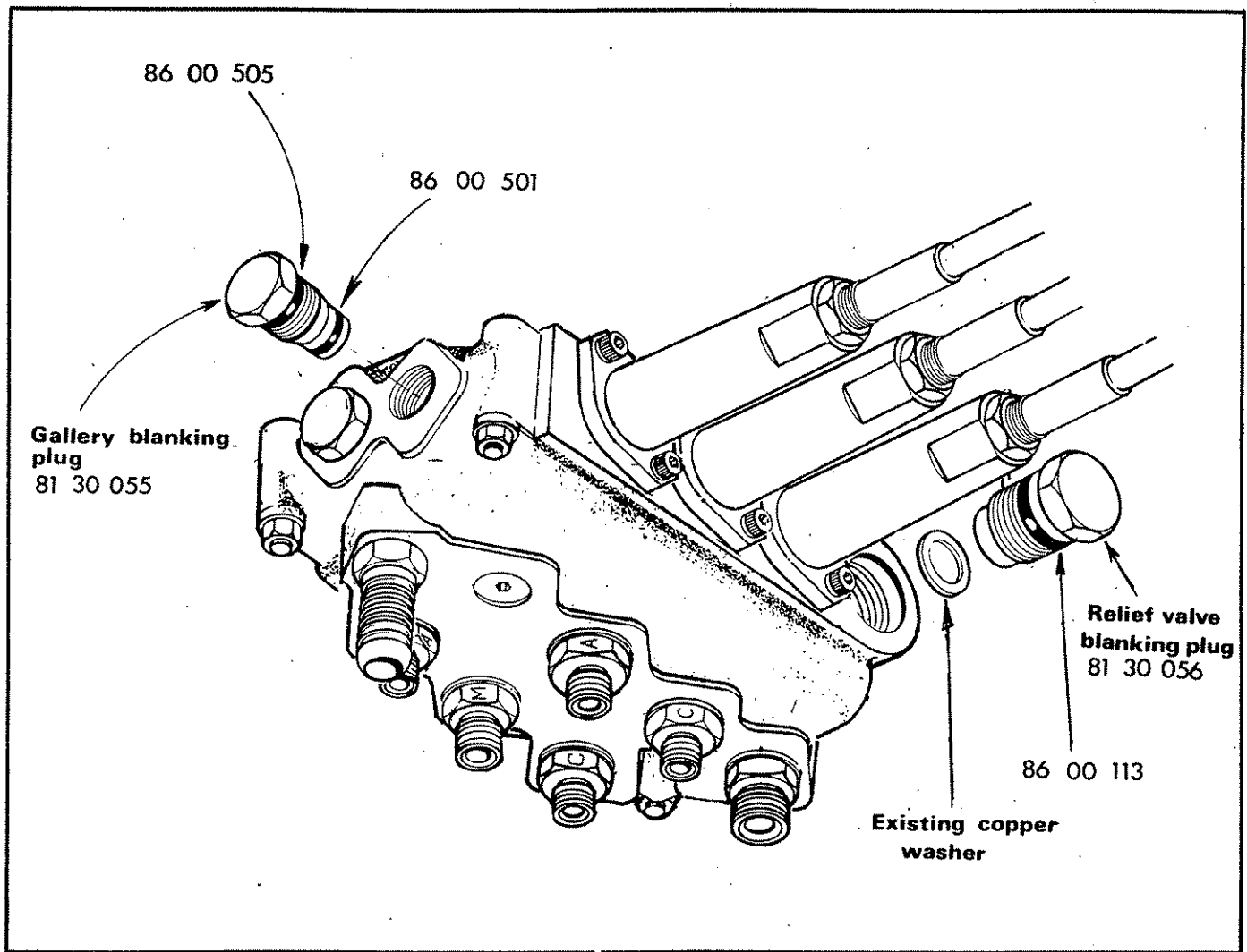

CLOSED CENTRE CONVERSION KIT 81 30 059 for S.i. models only

A control valve conversion kit Part No. 81 30 059 consists of a relief valve blanking plug which should be installed in place of the existing relief valve and a pressure gallery blanking plug which is installed in place of the standard blanking plug at the valve outlet end next to the lift ram gland connection.

Take care when extracting the relief valve not to damage the copper sealing washer as it is re-used.

When working in this mode the tractor's pressure control valve must not exceed 2500 P.S.I. (170 Bar).

OIL REQUIREMENTS

Tank

The machine is delivered from the factory without oil. Fill the reservoir with a light hydraulic oil as recommended in the chart until the oil level is approximately 3" below the top of the tank. The total capacity is approximately 65 litres (14 galls). Do not overfill.

Supplier	Cold or temperate climate	Hot climate
Castrol	Agricastrol hydraulic oil Hy-spin AWS46	Hy-spin AWS68
Shell	Tellus 46	Tellus 68
Mobil	D.T.E. 25	D.T.E. 26
Esso	Nuto 'H' or 'A' 46	Nuto 'H' or 'A' 68
Texaco	Rando HD 46	Rando HD 68
Gulf	Hydrasil 46	Hydrasil 68
B.P.	Energol HLP 46	Energol HLP 68
Dalton	Silkolene Dove 46 or Derwent 46	Silkolene Dove 68
Elf	Hydrelf 46	Hydrelf 68
ISO VG	46	68
SAE	10W	20

Gearbox

Check the gearbox oil level. On level ground it should be filled until oil is visibly level with the lip of the filler plug aperture. Do not attempt to fill by removing the breather as the depth of tapped thread in the casing at this point is insufficient to allow repeated loosening and tightening of the breather plug.

The gearbox capacity is 700 millilitres (1 1/4 pint use EP 90 gear oil).

ATTACHMENT TO TRACTOR

Before commencing select a firm level site, cut the banding straps and remove loose items and the stabiliser. Leave the transport straps at this stage.

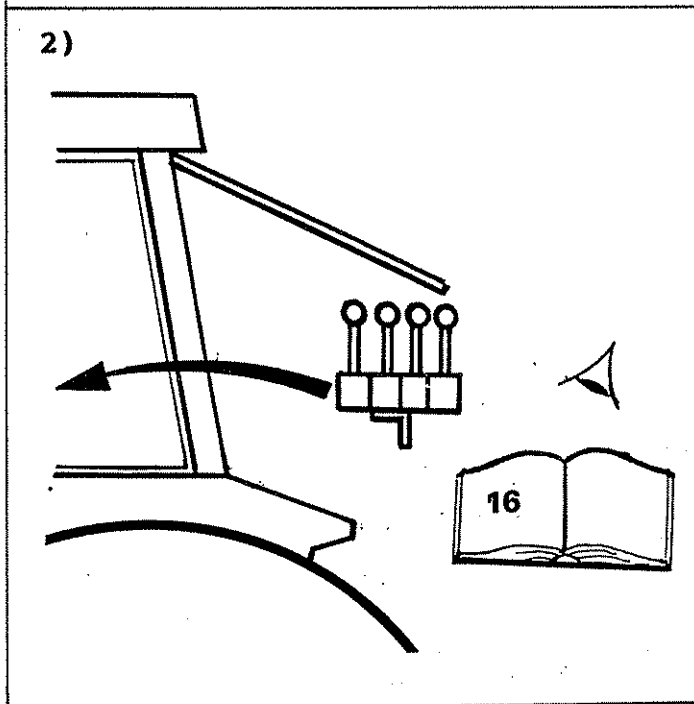
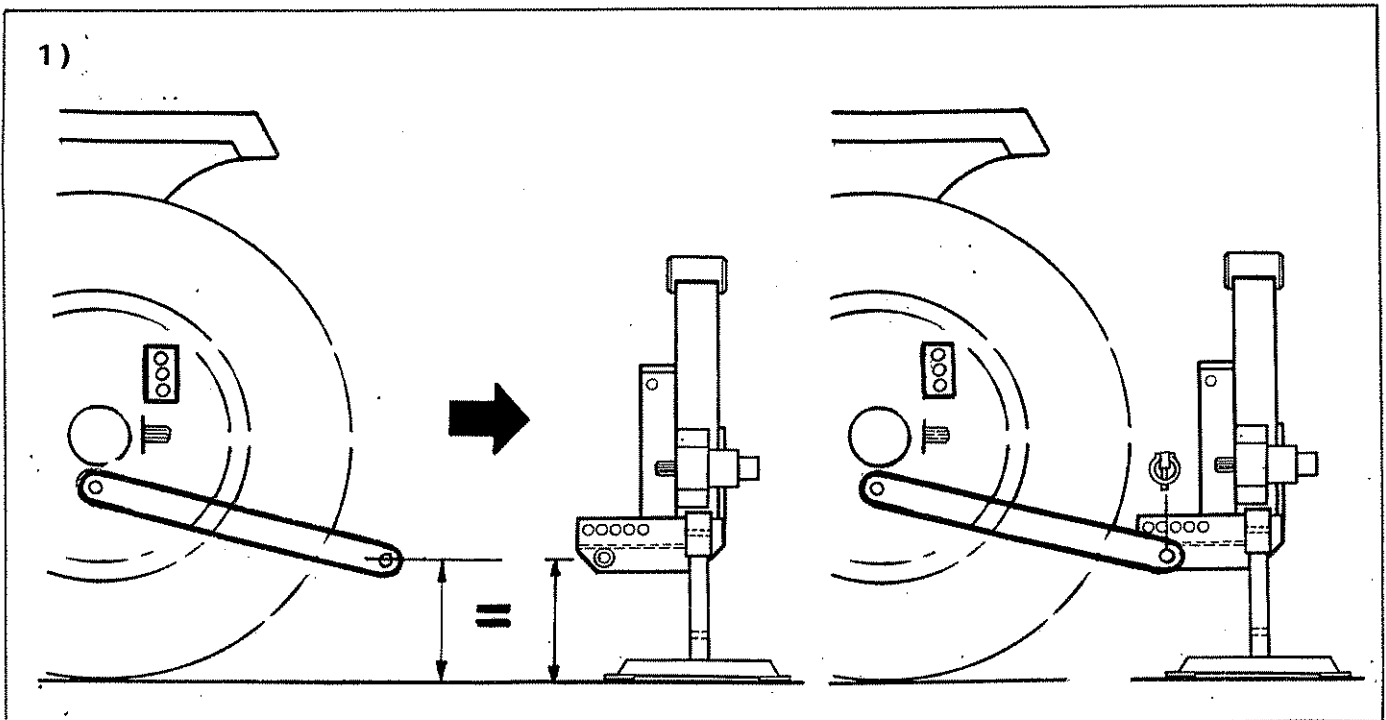

3) Si only

Connect supply and return hoses to tractor. Supply is taken from the tractors auxiliary service. Return is direct to the tractors transmission casing (see tractors handbook for correct procedure). Extra hoses and fittings may be required.

4)

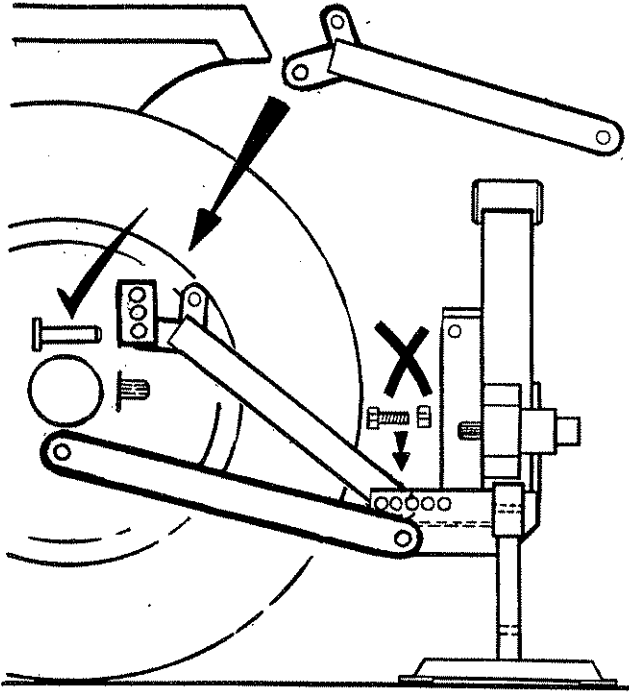

5)

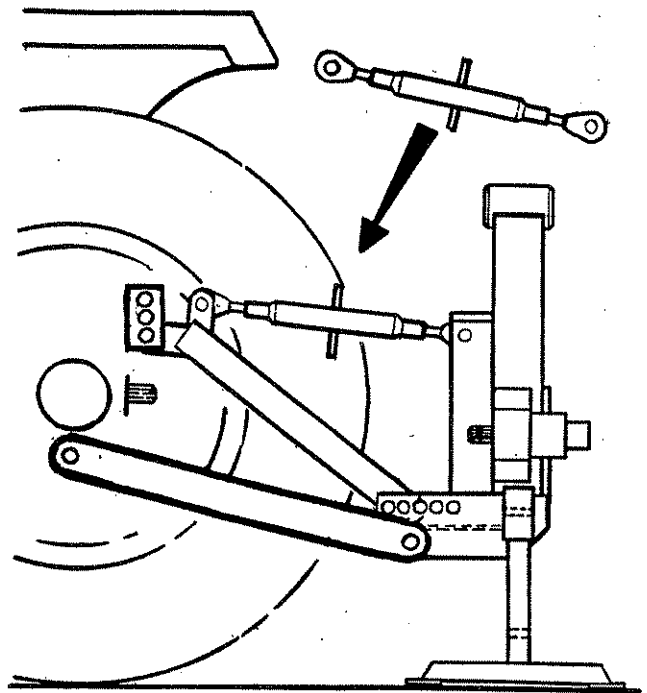

6)

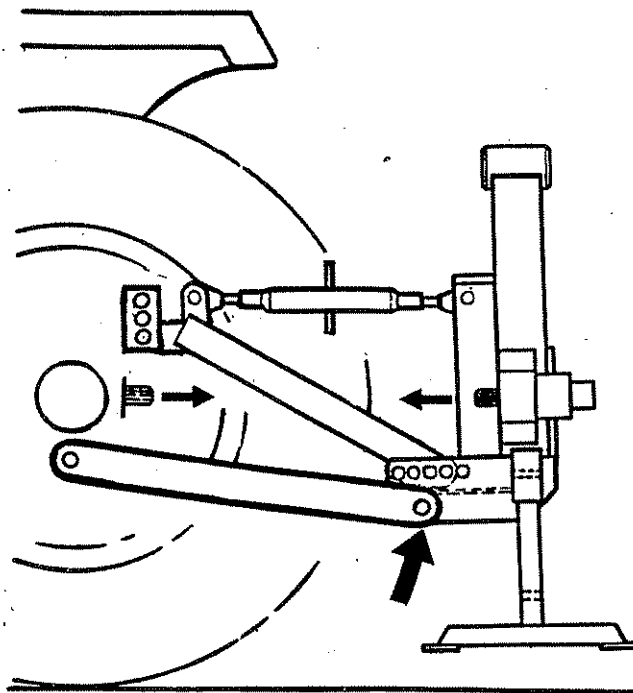
**WARNING**

The quadrant lever or machine controls must be operated from the tractor seat. During this operation ensure no one is standing on or amongst the linkage arm or bars.

Note:

As lift occurs be aware the machinery may tilt slightly.

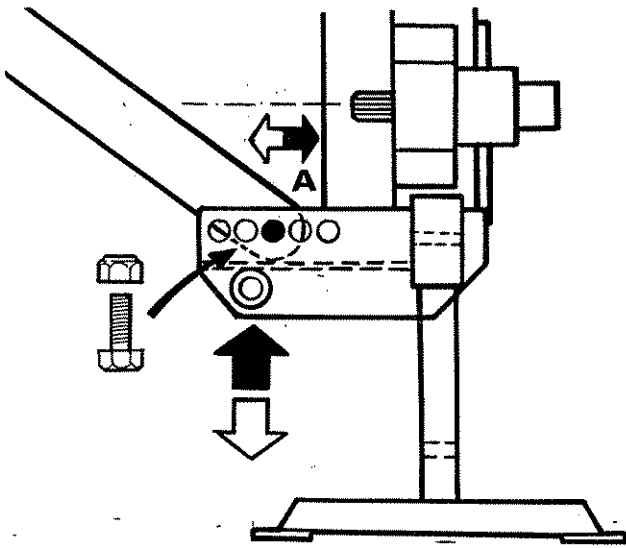

- 7) Fine adjust 'A'.
Use the mounting hole that allows the PTO and gearbox stub shaft to as nearly as possible in alignment.

- 8) Lower tractor linkage control so that machines weight is taken by the yoke and :-

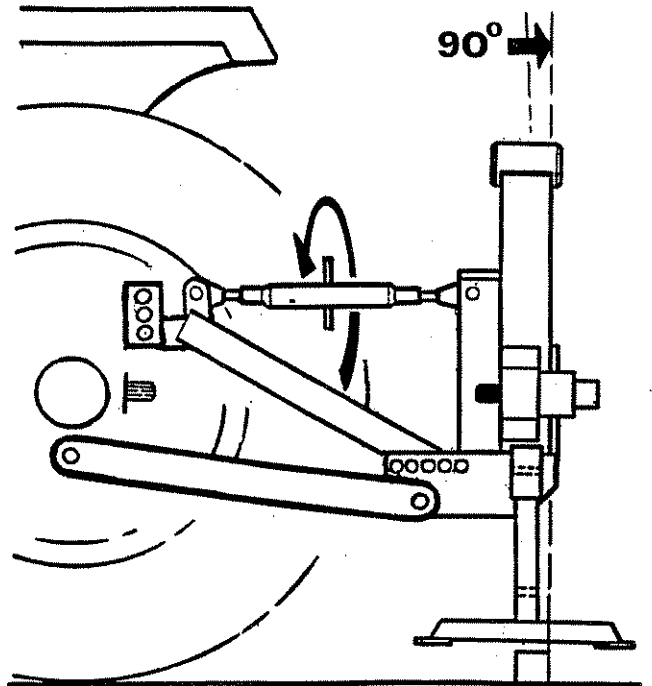

9)

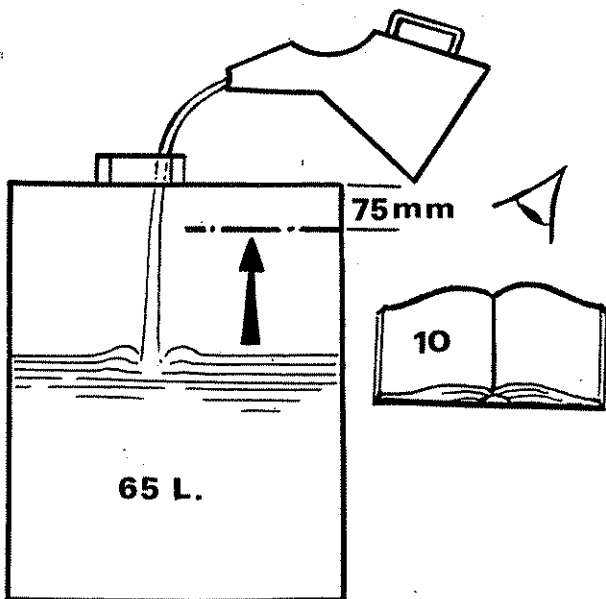

10)

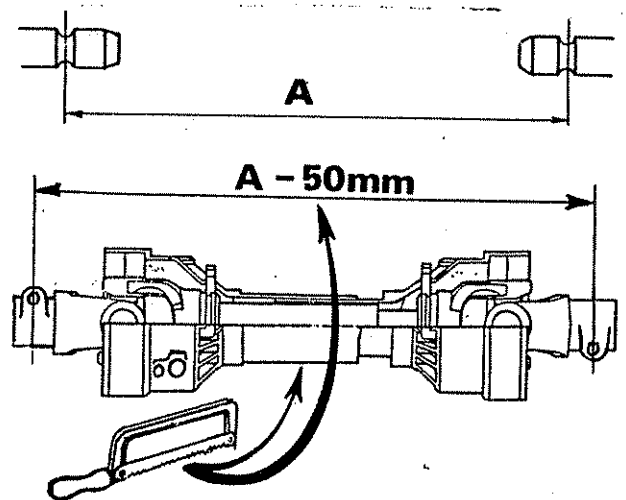

- Measure 'A'.
Cut PTO shaft equal amounts of both halves to measure. A - 50mm when fully closed.

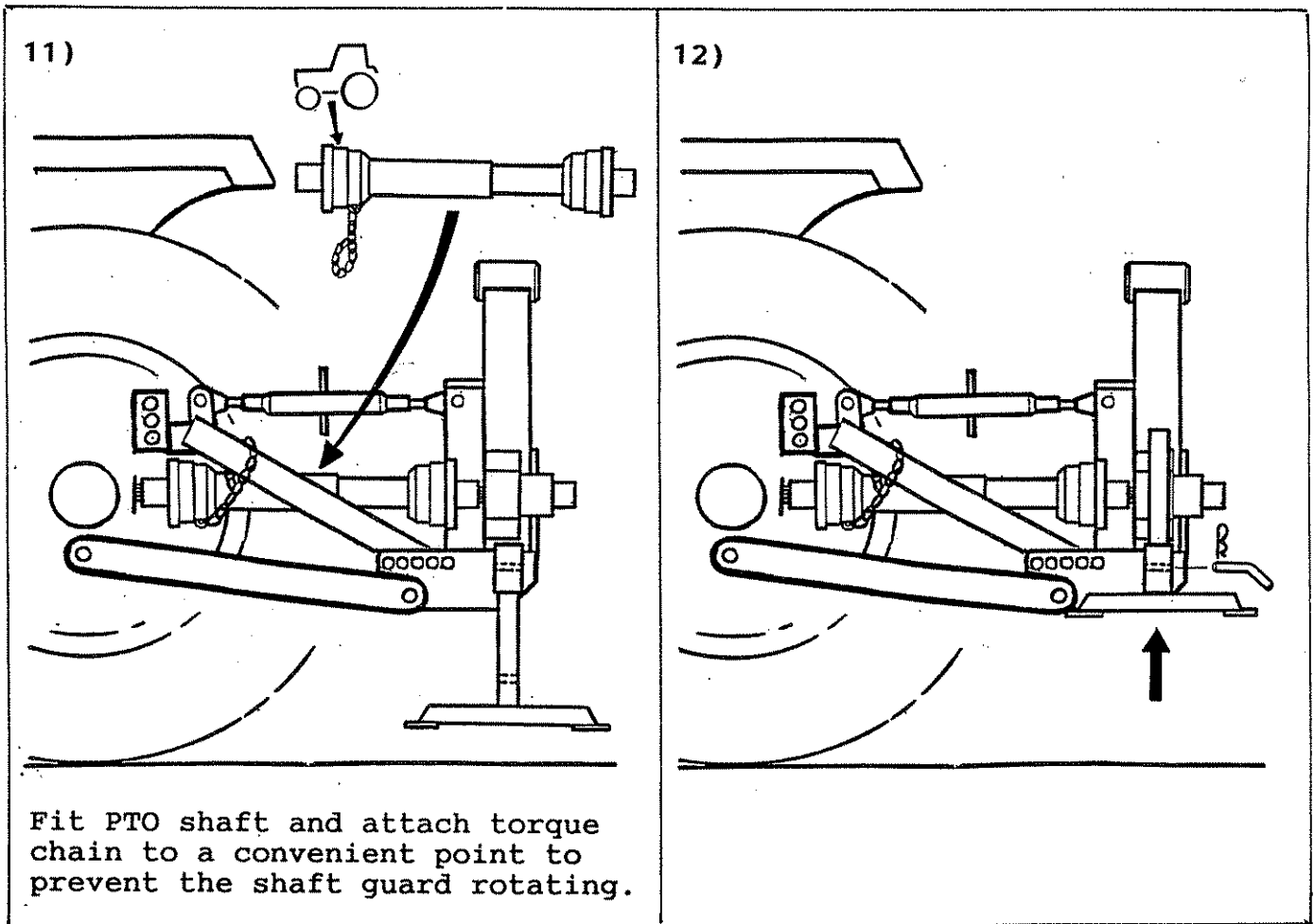

13) Remove transport strap.

14) With tractor external services activated on Si models or with PTO engaged on Ti models manoeuvre the arms into a position that will allow the cutter head to be fitted. Fill cutter head and secure with circlip, washers and split pin.

15) Cutterbar only
Engage motor splines in the drive tube and bolt in position with connection uppermost.

16) Connect hoses.

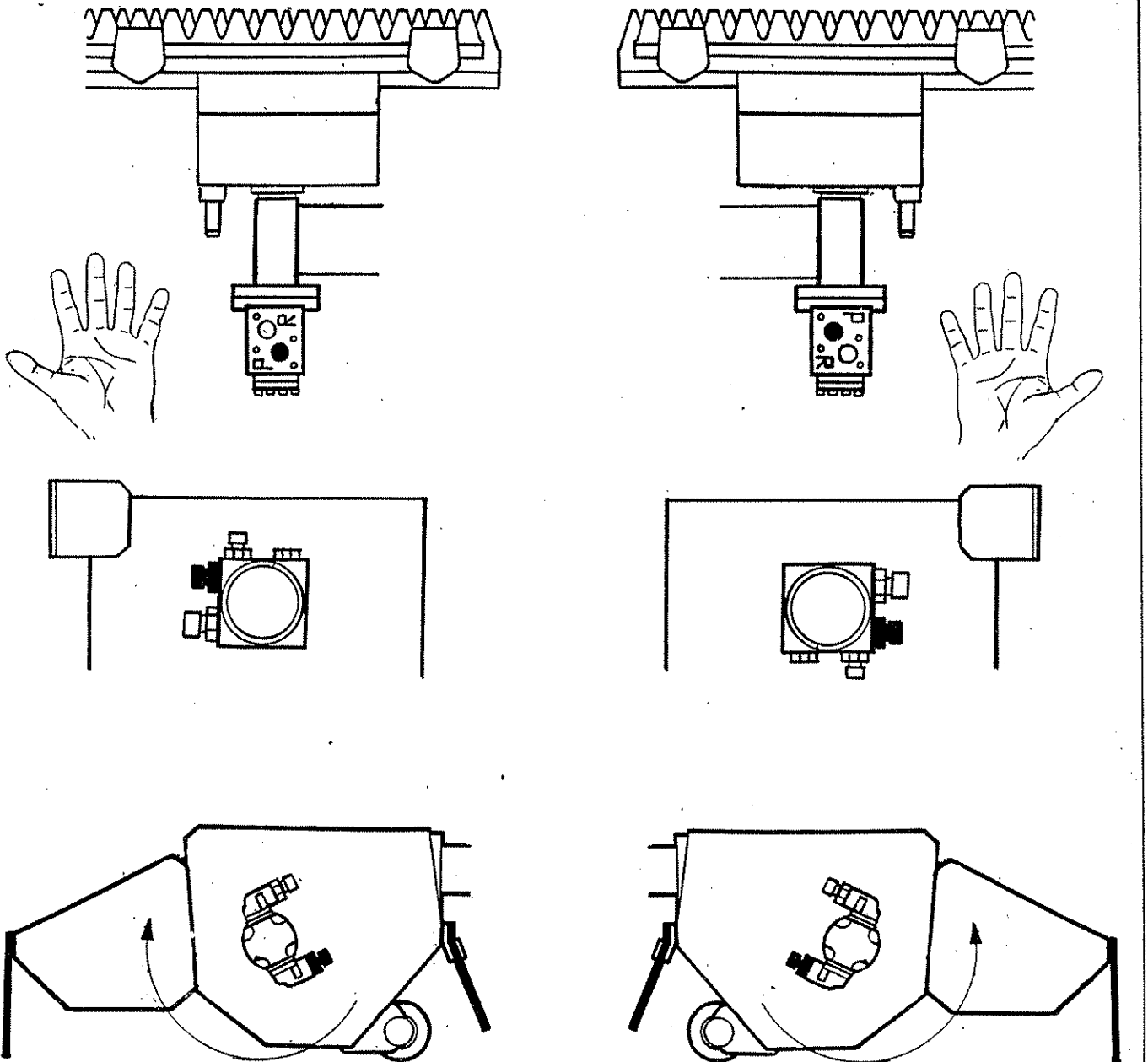

17) Carry out final adjustment of the tractor lift arm levelling box to bring the main frame horizontal. This should be checked at half reach with cutter head clear of the ground.

18) Tighten check chains/stabiliser bars.

19) Carefully operate the machine through its full range of movements whilst checking that hoses are not strained, pinched, chafed or kinked and that all movements are functioning correctly.

20) Fold machine into the transport position (see page 22). The machine is now ready to transport to the worksite.

FITTING CONTROL UNIT IN CAB

An angled bracket is supplied to provide a mounting location for the control unit.

This bracket may be bolted to the mudwing or cab cladding in a convenient location ensuring that no structural member of the cab or roll bar is drilled.

In deciding the final position of the control box remember not to exceed the minimum acceptable bend radii of 8" for the cables.

When the control unit is removed from the cab ensure the rubber edge strip is fitted to the mounting bracket to cover any possible sharp edges.

RUNNING UP PROCEDURE

Ti models only - with flail head only.

Ensure that the rotor control valve is in "STOP" position, start tractor, engage P.T.O. allow the oil to circulate through the return line filter for about 5 minutes without operation of the armhead control lever.

Operate the armhead levers through their complete range ensuring that all movements are functioning correctly.

Place the flail head at a safe attitude and move the rotor control to "START" position. After initial fluctuation the rotor should settle to a steady speed. Increase P.T.O. speed to approximately 360 rpm. and run for a further five minutes before disengaging and stopping tractor.

Check the hose runs and observe that they are free from any pinching, chafing, straining or kinks. Re-check the oil level in the tank and top up as necessary.

Si models only - with cutterbar or flail head.

Ensure P.T.O. lever is in neutral position, and isolate tractor hydraulic linkage. Start tractor and select external service supply. Allow the tractor to run for several minutes before attempting to operate any of the machine control levers.

On operating move the levers through their complete range ensuring that all movements are functioning correctly.

Check the tractor rear axle oil level and top up if necessary.

On cutterbar models ensure the motor hoses are connected correctly - see page .

Place the cutterhead at a safe attitude and bring tractor engine revolutions to 1000 rpm. Engage P.T.O. and allow the cutter to run for several minutes. Do not leave the tractor cab or allow anyone to approach the cutter head at this time.

Caution

Do not allow the pump to continue working if the cutter does not operate. Overheating and serious damage to the pump can be caused in a very short time.

After running up the machine increase P.T.O. speed to approximately 360 rpm. and run for a further five minutes to allow the oil to circulate through the return line filter before disengaging the P.T.O. and stopping tractor.

Check the hose runs and observe that they are free from any pinching, chafing straining or kinks. Re-check the oil level in the tank and top up as necessary.

REMOVAL FROM TRACTOR

DANGER

READ CAREFULLY BEFORE COMMENCING TO REMOVE THE MACHINE FROM THE TRACTOR.

THE ORDER OF THE FOLLOWING STEPS MUST BE FOLLOWED EXACTLY

DISCONNECTING THE TOP LINK MUST BE THE LAST OPERATION PRIOR TO DRIVING THE TRACTOR AWAY FROM THE MACHINE

WARNING

Do not operate quadrant lever or machine controls through the rear cab window whilst standing on or amongst linkage components.
Always seek assistance.

Select a firm level site for parking the machine.

Lower the parking legs and secure.

Operate the hydraulic service to place the arms at half to three quarters reach and with the flail head roller or cutterbar horizontal and level with the bottom of the parking feet.

Disengage tractor P.T.O. and remove.

Disconnect stabilizer bars or loosen check chains as applicable.

Unbolt the control unit from the mounting pillar, remove from tractor cab and stow in a suitable location clear of the ground. On Si models only the supply and return hoses must be disconnected from the tractor and stowed with their ends covered and clear of the ground.

Raise the machine on the tractors linkage to take the weight off the yoke and remove the lower yoke bolts.

Lower the tractor draft links and place machine firmly on the ground.

Remove draft links and top link from the machine, drive tractor away and remove yoke.

STORAGE

If machine is to be left standing for an extended period of time, lightly coat the exposed portions of the ram rods with grease. Subsequently this grease which becomes contaminated with dust and grit should be wiped off before the rams are next moved.

If the machine has to be stored outside tie a piece of tarpaulin or canvas over the control assembly - do not use a plastic fertilizer bag which could lead to rapid corrosion.

OPERATION

MATERIAL THICKNESS CUTTING LIMITATIONS

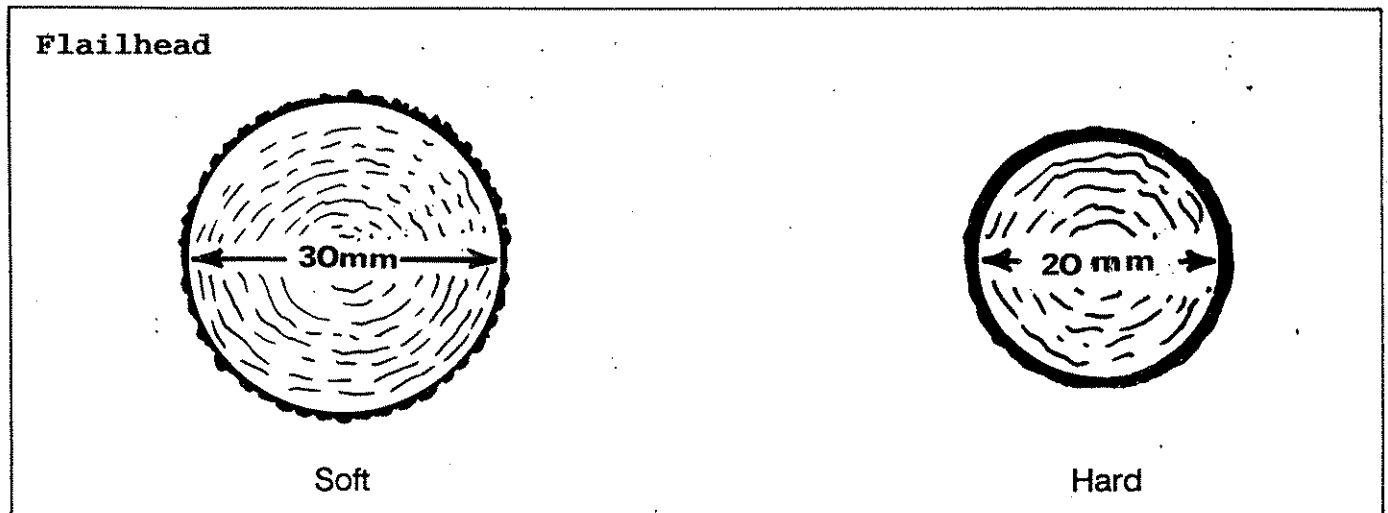

Cutterbar

The cutterbar is light trimming tool.

Attempting to cut unsuitable material will cause the knife to stall resulting in motor's relief valve blowing and overheated oil.

OPERATOR GUARD

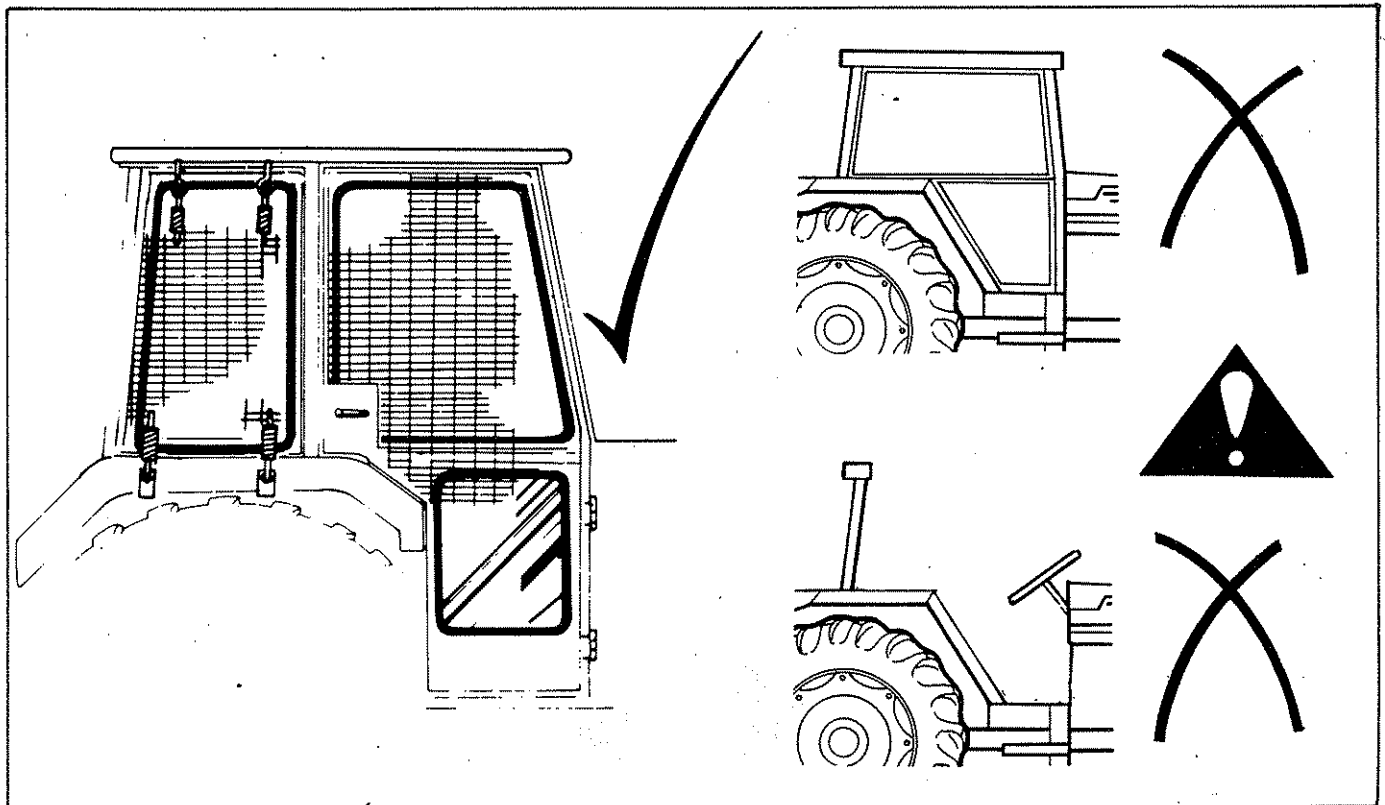

PREPARATION

Read the book first

Practise in an open space without rotor running until familiar with controls.

Caution: Take care when working with the head close in as it can hit the tractor.

MACHINE CONTROLS

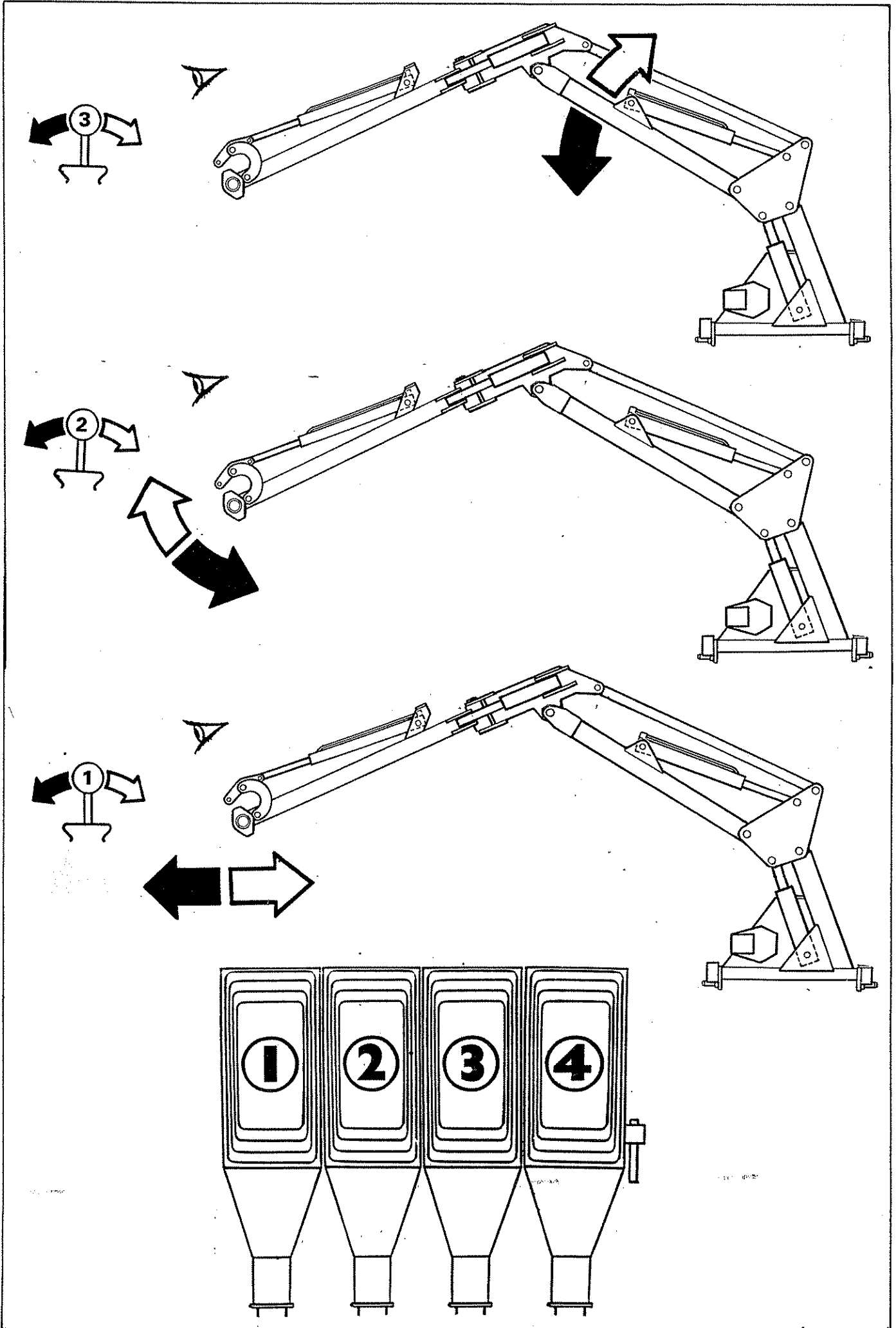

ROTOR CONTROLS - Ti machines only

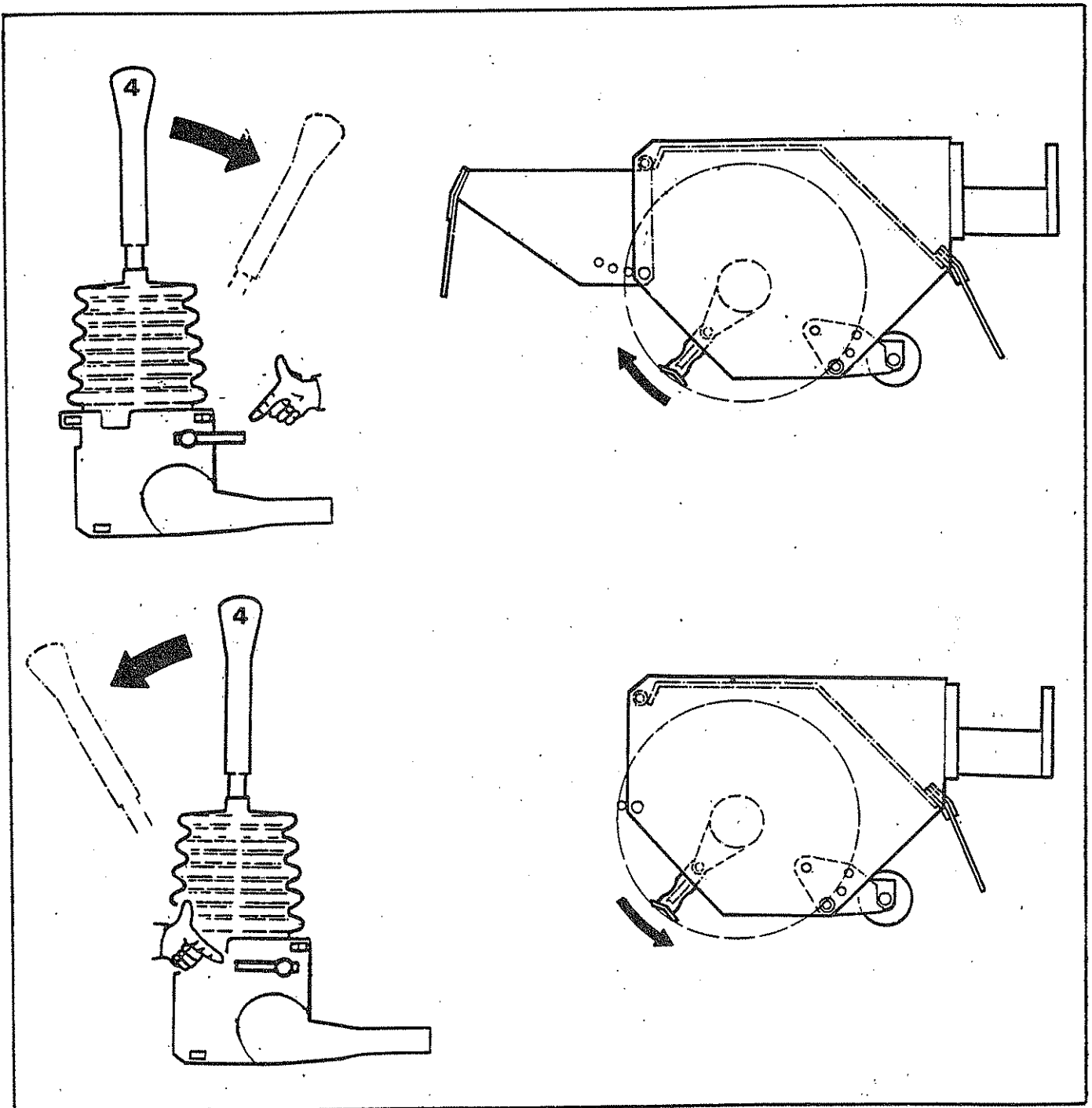

Select "Rotor OFF"

WAIT until the rotor has stopped turning.

Turn the small lever on the side of the rotor control lever pivot box through 180 degrees. This will reset the control lever stop inside the pivot box and allow opposite rotation to be selected.

MINI ELECTRIC PROPORTIONAL CONTROL

CONTROLS IDENTIFICATION

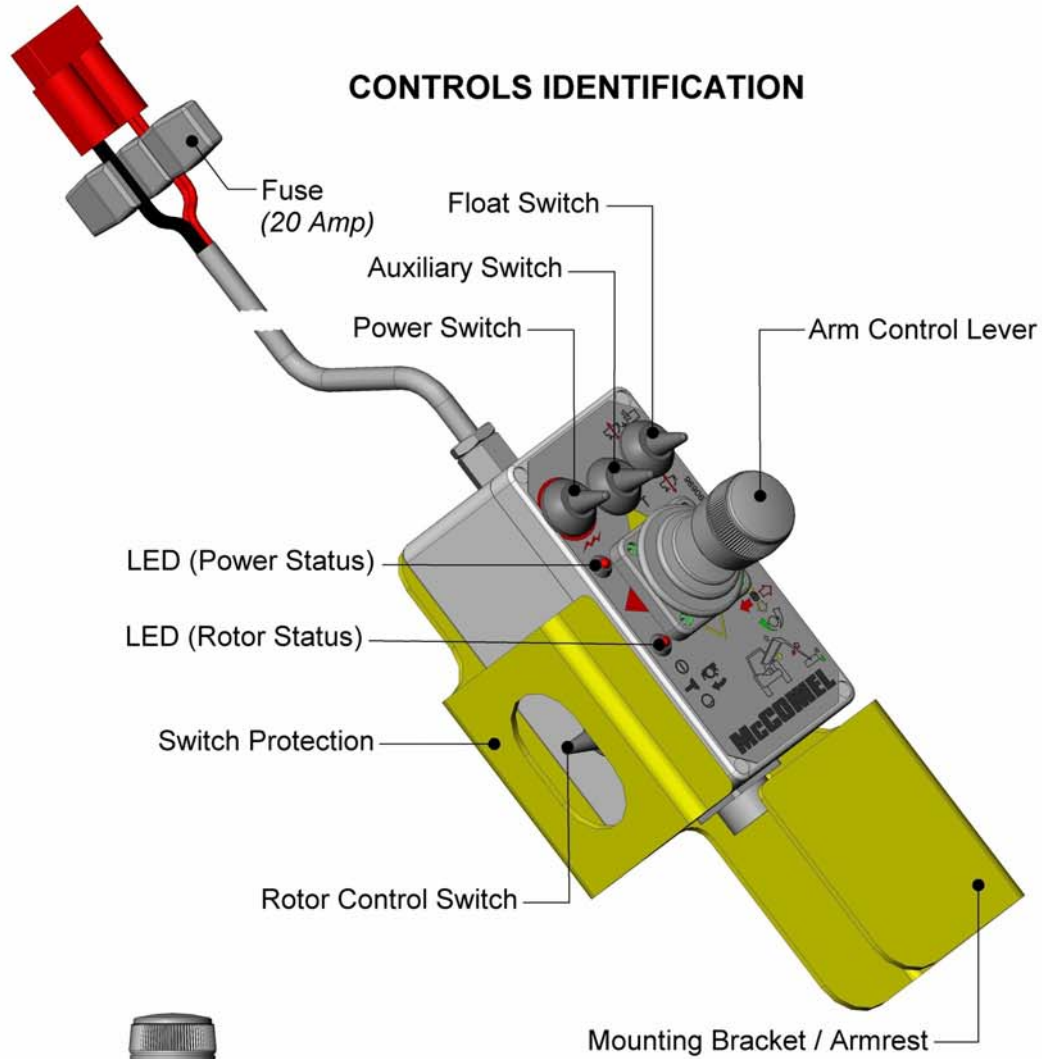

ELECTRICAL CONNECTIONS

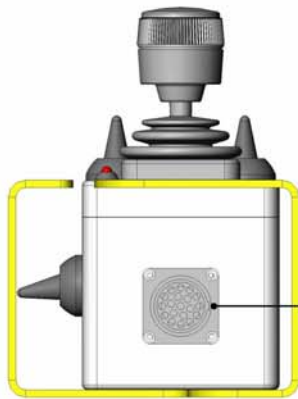

- A - COMMON
- B - REACH IN
- C - REACH OUT
- D - LIFT UP
- E - LIFT DOWN
- F - COMMON
- G - N/A
- H - N/A
- J - ANGLE DOWN
- K - ANGLE UP



- L - N/A
- M - N/A
- N - COMMON
- P - ANGLE FLOAT
- R - LIFT FLOAT
- S - PUMP 1
- T - AUXILIARY
- U - N/A
- V - CUT OFF

SWITCH FUNCTIONS

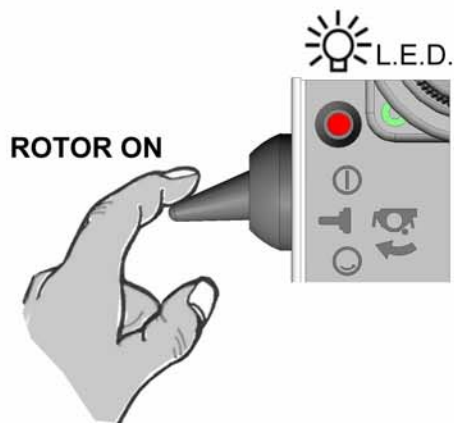
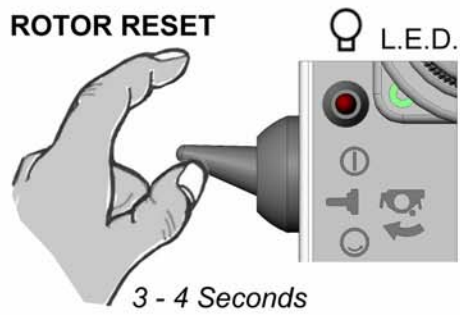
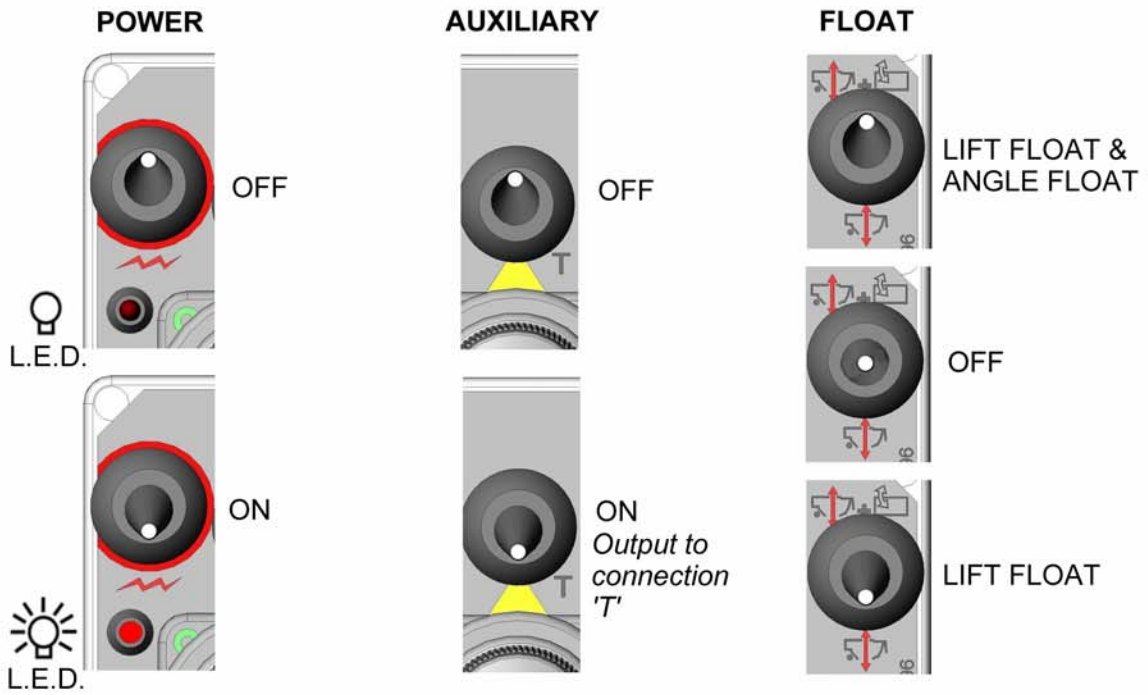

ARM OPERATION

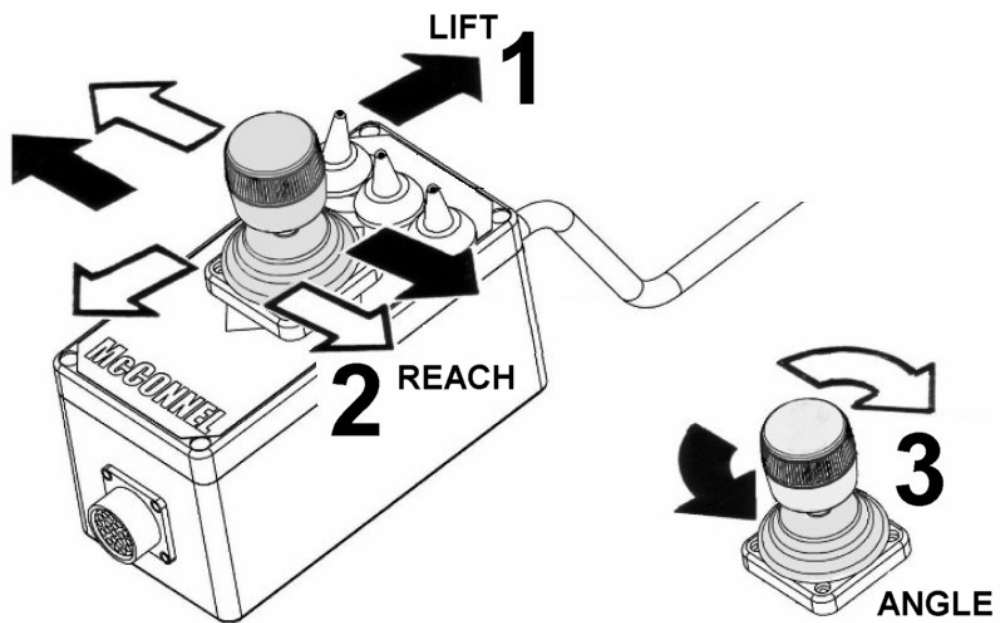
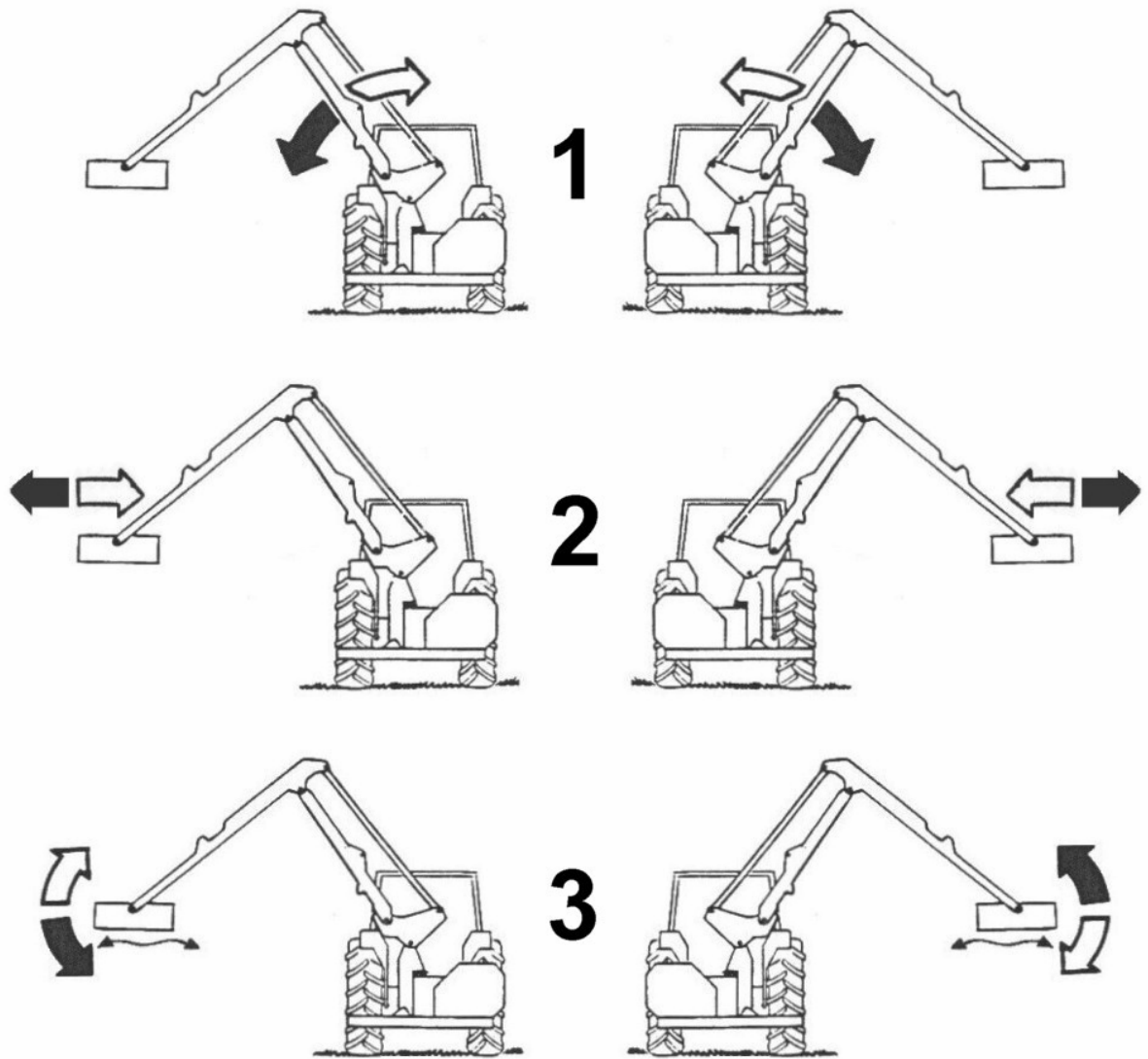

TRANSPORT POSITION

For transport on the public highway the flail must be folded within the overall width of the tractor.

PA32 with flail head

Position the arm until the head is approximately four feet (1.5m) clear of the ground and the dipper is horizontal.

Pull the dipper arm to the rear to remove tension on the breakaway ram base pin and remove it.

Manually break back the dipper until the base of the ram is re located between the inboard holes in the ram lugs. Replace the ram base pin.

Select '**Lift up**' until the main arm is as high as it can go without projecting beyond the tractor width. Fully select '**Reach in**'. Select '**Angle down**' to turn the flails towards the tractor.

For off road transport where width is not critical it will be sufficient to fully fold the arms.

PA32 with cutterbar

With cutterbar horizontal and with tractor switched off fit knife guard. Remember to keep fingers away from the knife as it can move even with the tractor engine switched off.

Select '**Lift up**' until the main arm is as high as it can go without projecting beyond the tractor width. Fully select '**Reach in**'. Fully select '**Angle up**'.

To revert to '**work**' mode, the above procedures must be reversed.

ENGAGING DRIVE

a) Ti models only

Ensure that the rotor control lever is in the '**Stop**' position before engaging the P.T.O. shaft. Allow the oil to circulate for a minute or so before operating the armhead levers. Position the flail head in a safe position, increase the engine speed to a high idle and move rotor control lever to '**Start**'. After initial surging the rotor will run at an even speed.

b) Si models only

On cutterbar models ensure that the motor hoses are connected correctly (*see page 15*) Place the cutter head at a safe attitude and bring the tractor engine revolutions to 1000 rpm. Engage the P.T.O. and slowly increase revs. until operating speeds are attained.

OPERATING SPEED

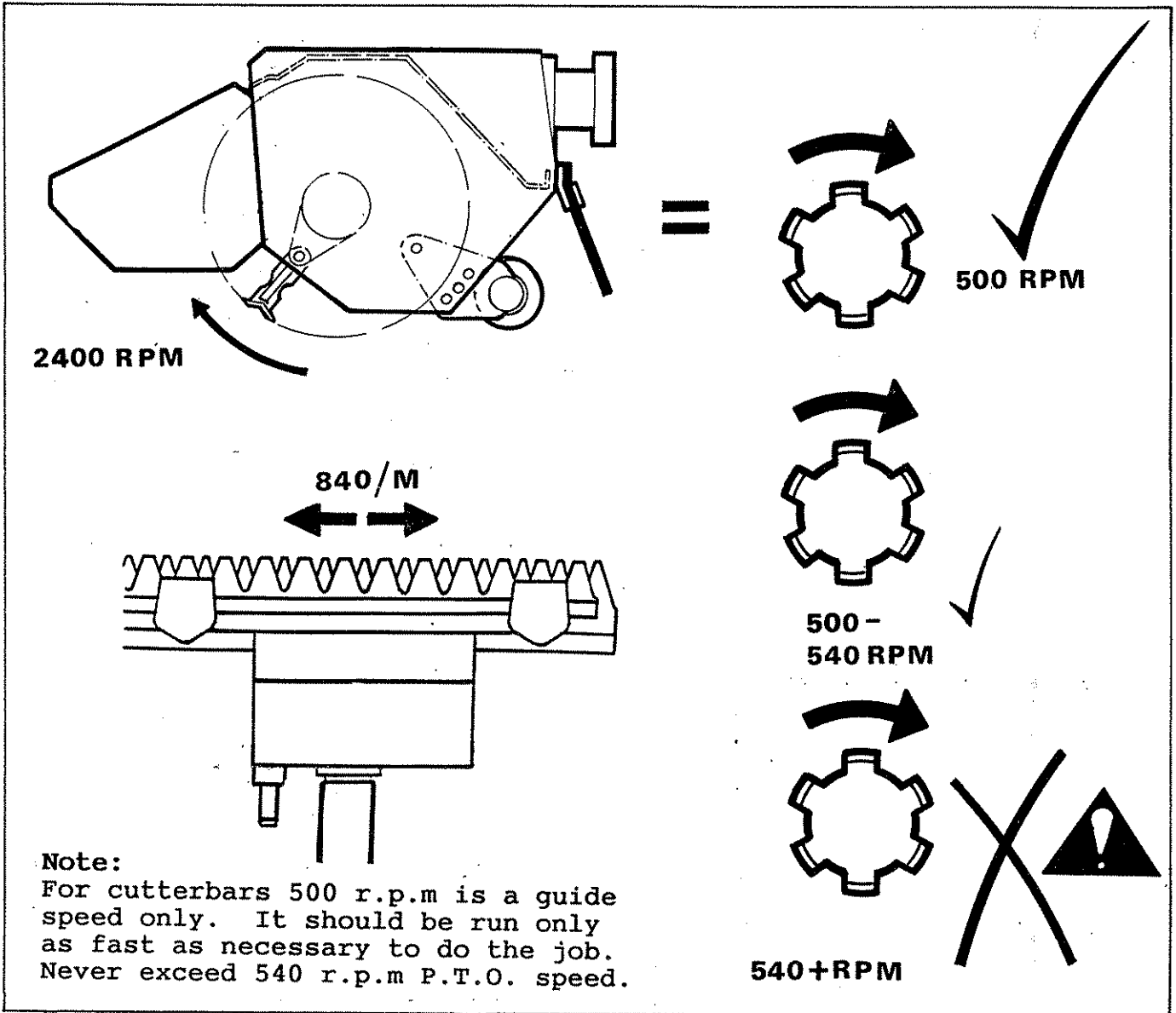

2400 RPM

840/M

500 RPM

500 - 540 RPM

540+RPM

Note:
For cutterbars 500 r.p.m is a guide speed only. It should be run only as fast as necessary to do the job. Never exceed 540 r.p.m P.T.O. speed.

TRACTOR FORWARD SPEED

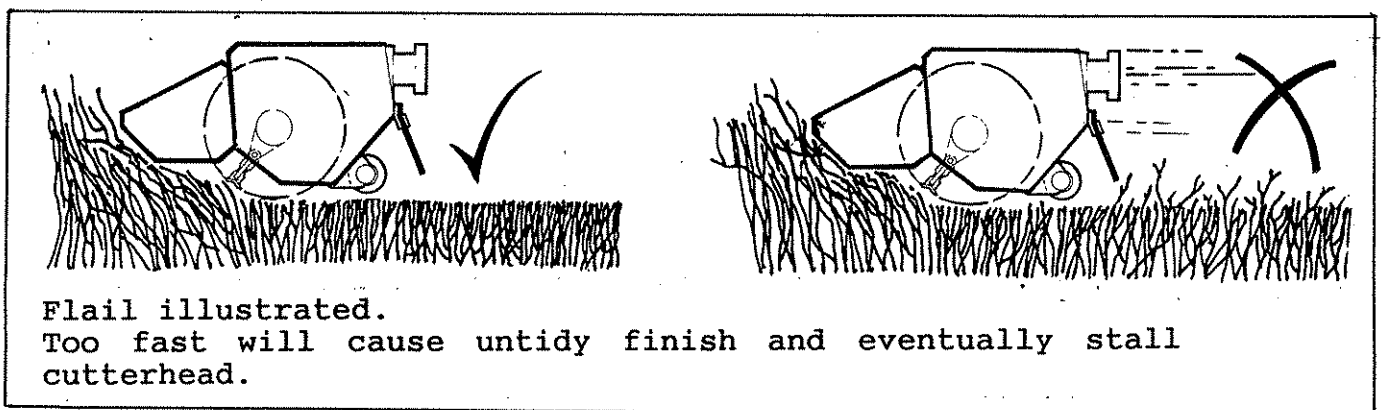

Flail illustrated.
Too fast will cause untidy finish and eventually stall cutterhead.

HIGHWAY WORKING

Local highway working regulations must be observed at all times.

WARNING

It is the operators responsibility to observe these regulations and to keep bystanders at a safe distance.

GENERAL WORKING PRACTISES

It is the operators responsibility to develop safe working procedures.

Always:-

Be aware of hazards in the vicinity

Make sure all guards are in position and in good condition

Disengage P.T.O. before stopping the engine.

Wait until the cutter has stopped running before leaving the tractor seat.

Disengage the P.T.O. and stop the tractor engine before making any adjustments.

Check frequently that all nuts and bolts are tight.

Keep bystanders at a safe distance.

BREAKAWAY

The pivoted arm is held and in line by the oil pressure in the fully extended breakaway ram. When the flail head meets an obstruction and the tractor continues to move forward oil pressure will build up, against a relief valve situated in the base of the breakaway ram. When the preset pressure is reached the valve will blow and the oil will be vented into the lift ram. This will allow the flail head to pivot backwards and at the same time cause the arms to rise. When the obstruction is cleared oil pressure contained in the lift ram will cause the arm and flail head to return to the work position.

WORKING CLOSE IN TO THE TRACTOR

When working close in to the tractor always be aware that the main arm projects beyond the tractors cab on the offside and potentially into the path of parked or oncoming vehicles.

WIRE TRAP - flail heads only

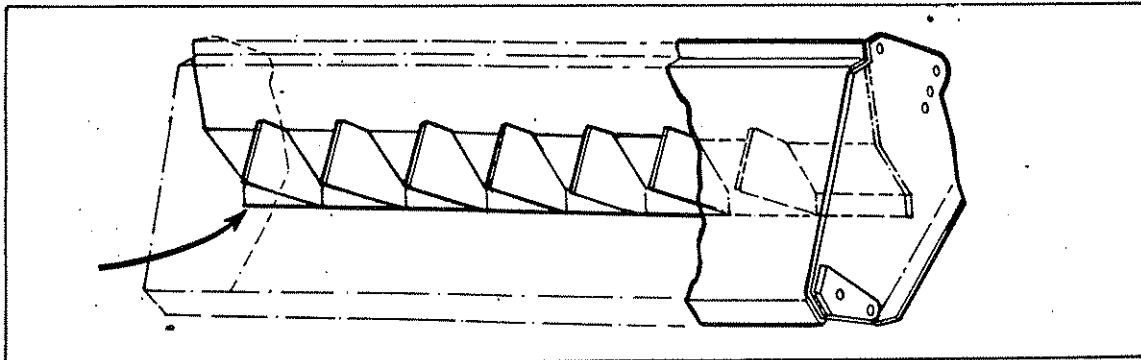

The flail head is equipped with a wire cutting edge welded into the underside. This plate should not be interfered with in any way.

Any wire caught in the rotor must be immediately removed.

REMOVING WIRE - flail heads only

Select rotor 'OFF' and wait until it has stopped rotating.

STOP the tractor and only then remove wire.

Do not reverse the rotor in an attempt to unwind any wire.

UNCLOGGING CUTTERBAR, CHECKS OR ADJUSTMENTS.

Before leaving the tractor seat select "Cutterbar - off" and switch off tractor engine. Should the cutterbar become clogged NEVER, NEVER, NEVER clear any debris from the fingers or knife with the hands. Use a stick from the hedge or other suitable tools.

WARNING

Always keep fingers away from the knife as the crankshaft fly wheel, can move under gravity and activate the knife even though the tractor engine is switched off.

OVERHEAD OBSTRUCTIONS

Always take extra care when manoeuvring in areas with overhead obstacles especially power cables.

HIGH VOLTAGE CABLES

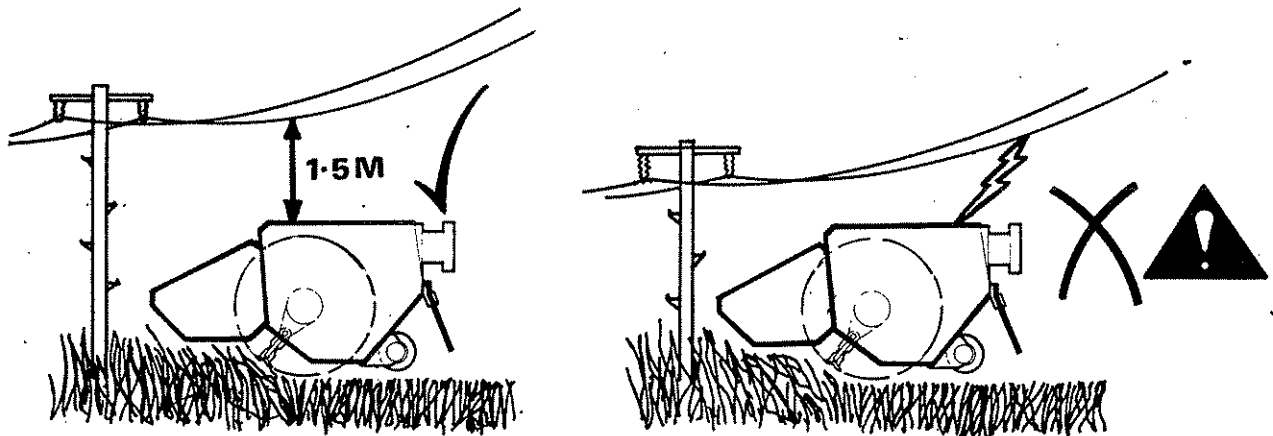

Flail head illustrated.
cutterbar.

Some dimension applies to

If in doubt consult your local electricity company regarding a safe procedure for work.

HEDGE CUTTING PROCEDURE

Preliminary Precautions

Inspect the work area, remove hazardous materials and note any immovable obstructions.

Upward cutting - flail head only

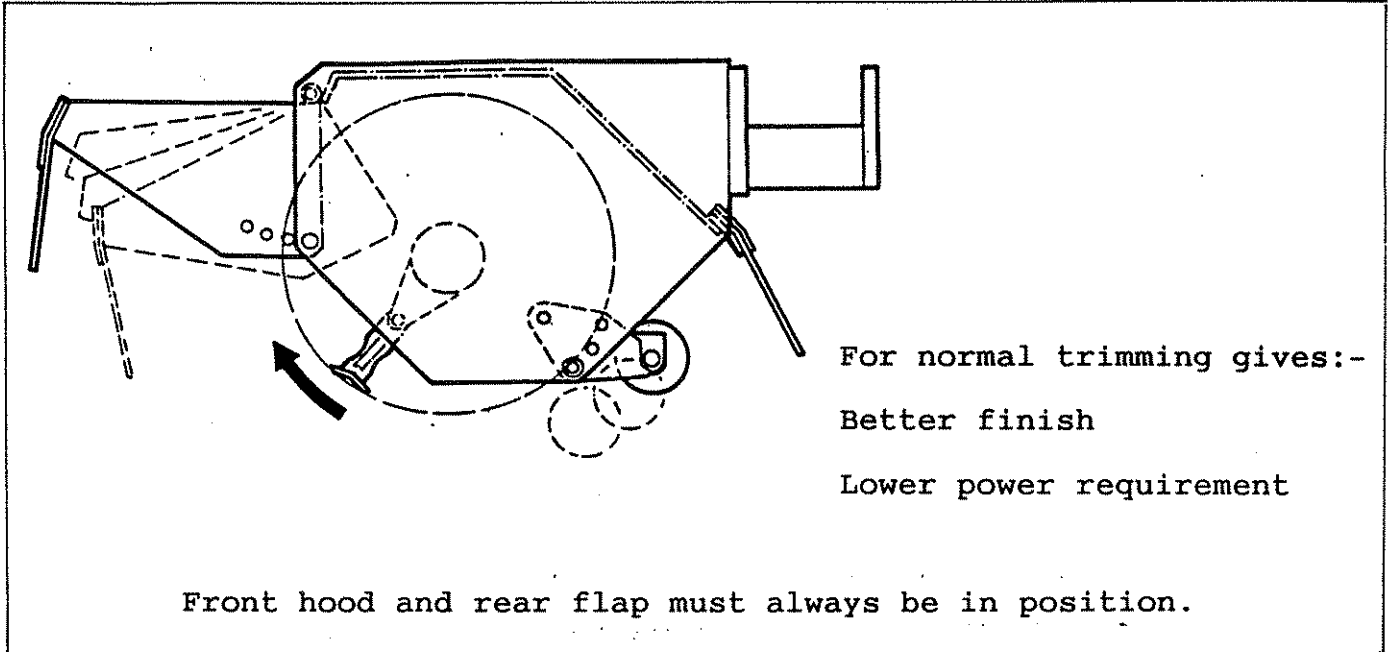

Downward cutting - Flail head only.

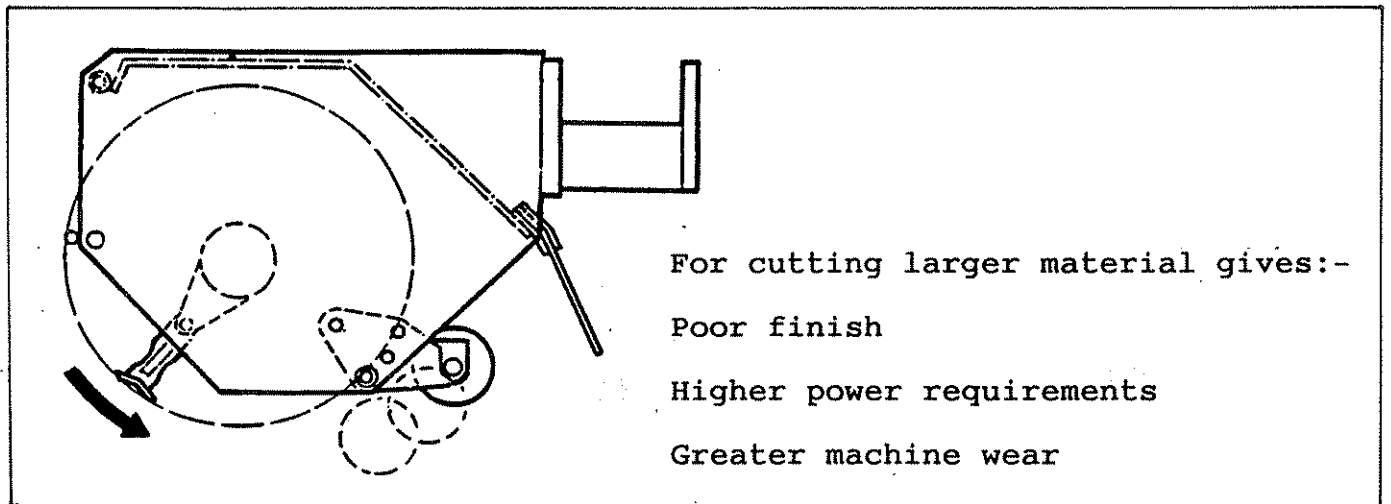

Reversing rotation - flail head only

Ti machines - see page 21

Si machines

The flail hose connections on the junction bracket at the lower end of the dipper arm must be interchanged.

Note if machine is converted to cutterbar configuration check hose connections to cutterbar motor carefully as the wrong connections could damage the knife drive.

CUTTING SEQUENCE - flail head only.

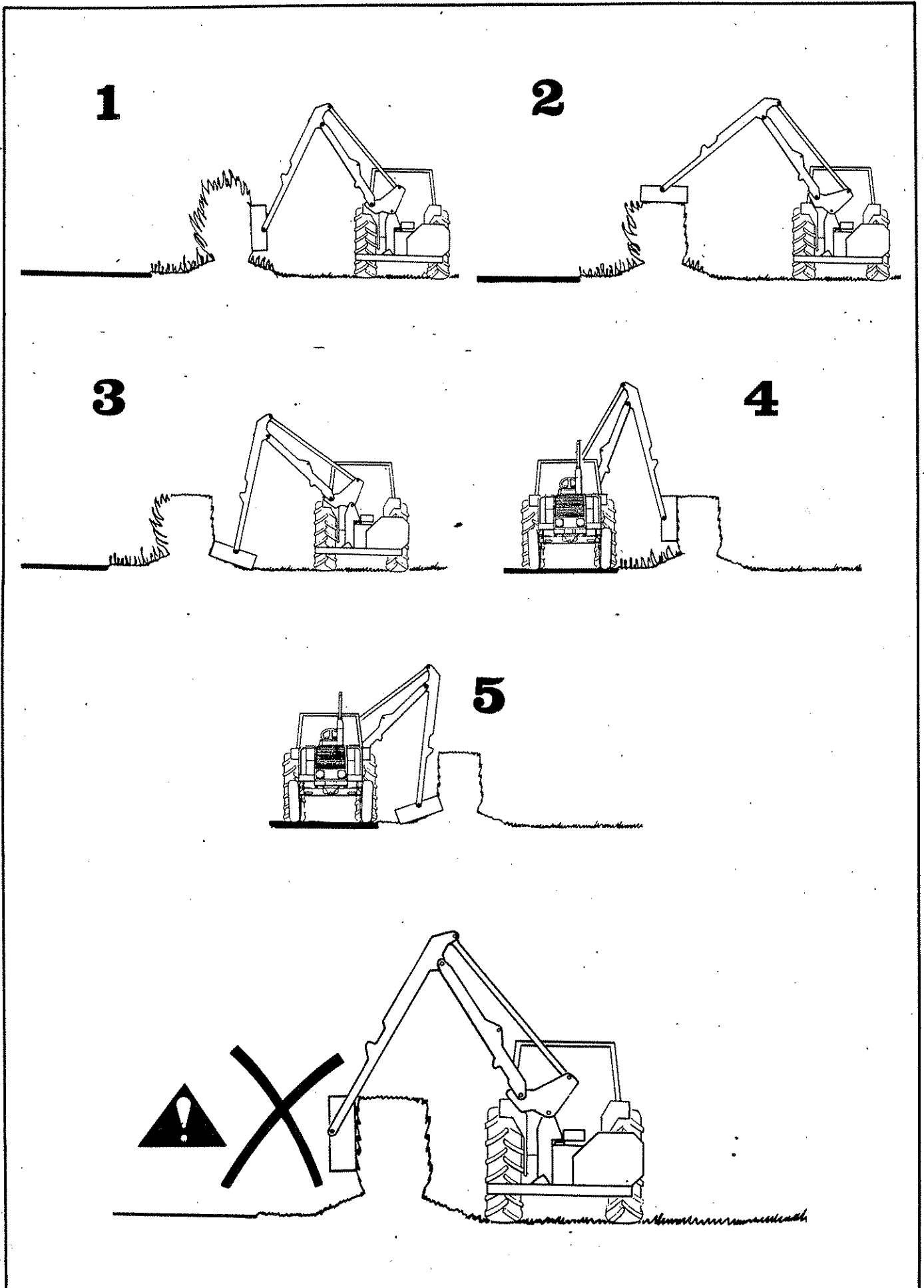

GRASS CUTTING - flail head only. (Flails must cut upwards).

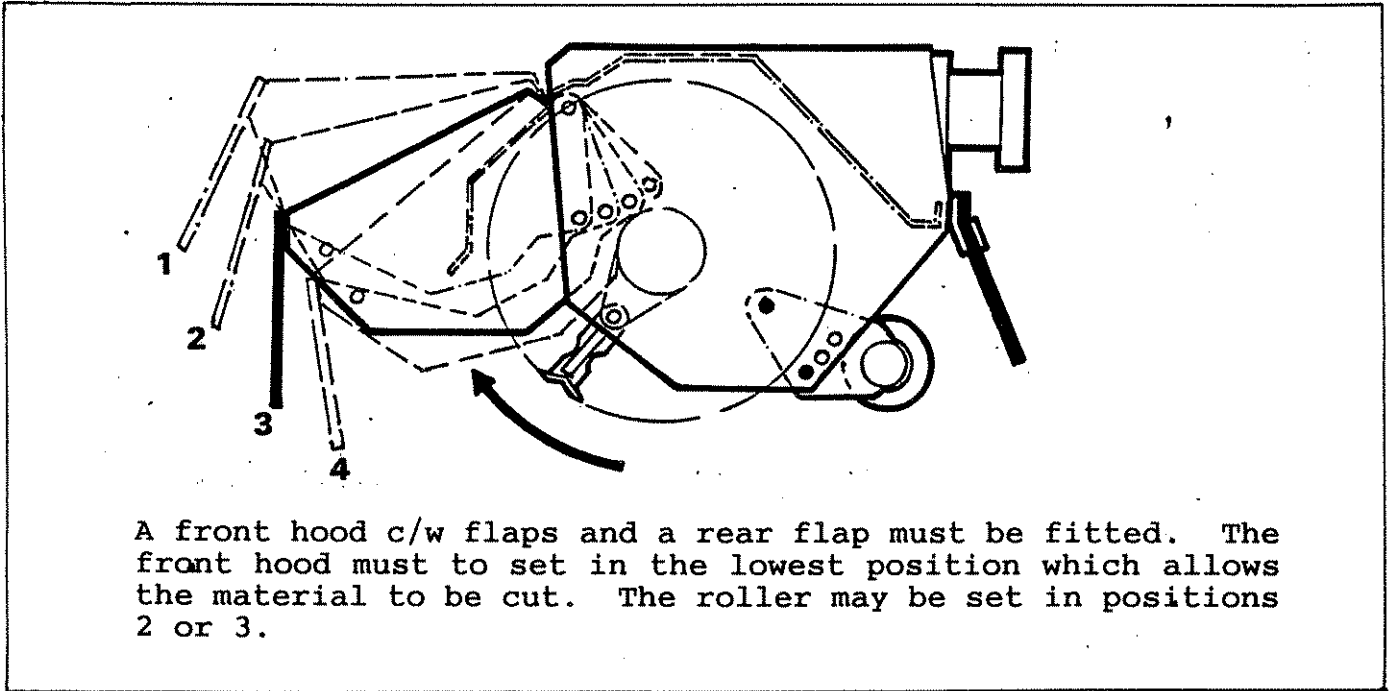

ROLLER POSITION - flail head only

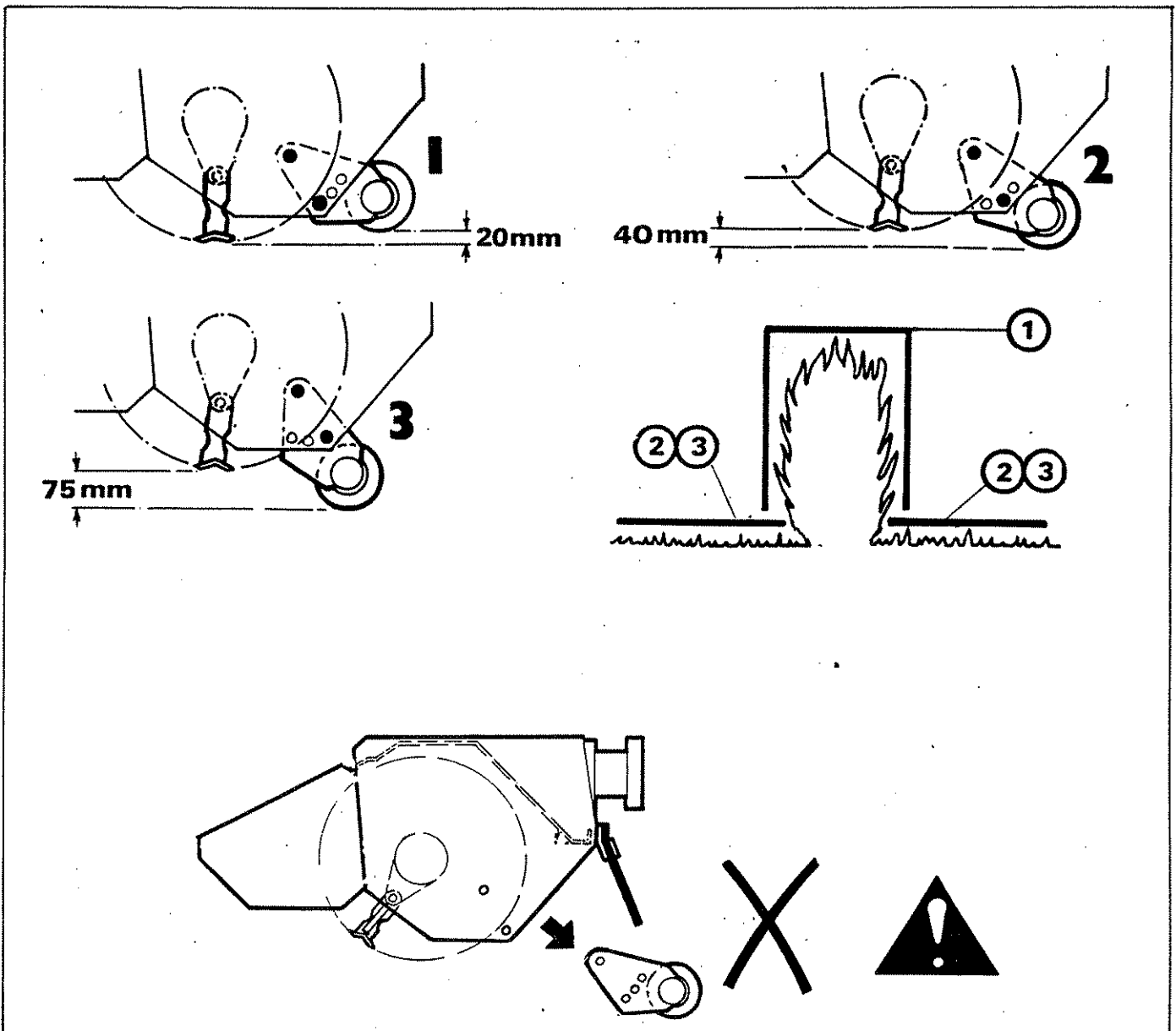

LIFT FLOAT KIT (Optional extra for ground cutting on flail machines only).

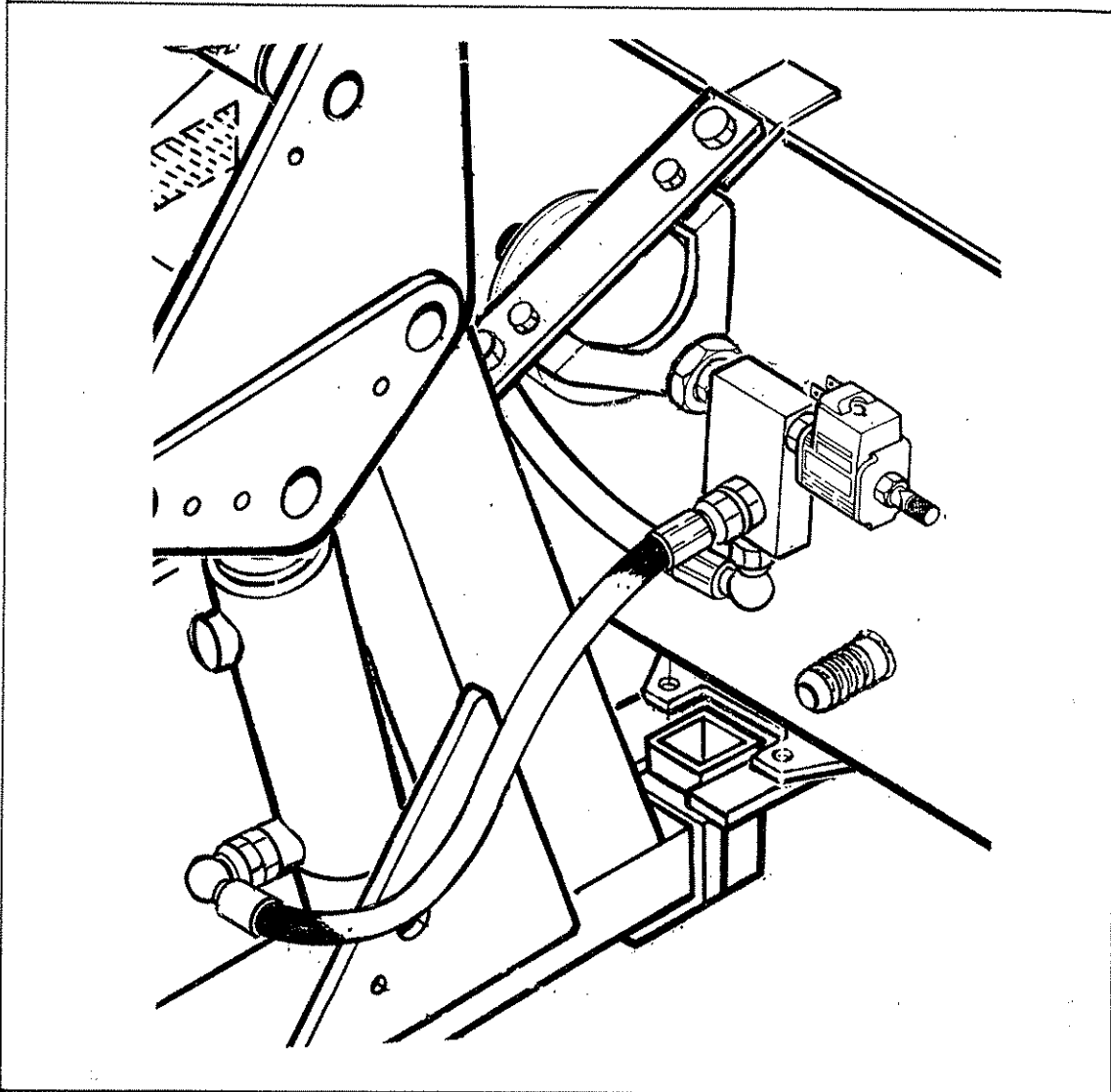

The hydraulic float kit, if fitted, should be mounted as shown bolted to the tank stay strap.

In work with the poppet valve open the flail head will automatically follow the ground contours.

The float action is engaged by manually lifting the knurled plunger on top of the poppet valve out of the V groove and rotating through 90 degrees.

The lift control should be operated to take a proportion of the flail head weight off the flail roller. This is important, too little weight on the roller will leave uncut areas of grass while with too much weight on the roller the ground will be scalped in places and increased flail wear, damage, or even loss of flails could occur.

To revert to standard operation the accumulator is isolated from the lift ram by returning the knurled plunger to the 'off' position.

MAINTENANCE

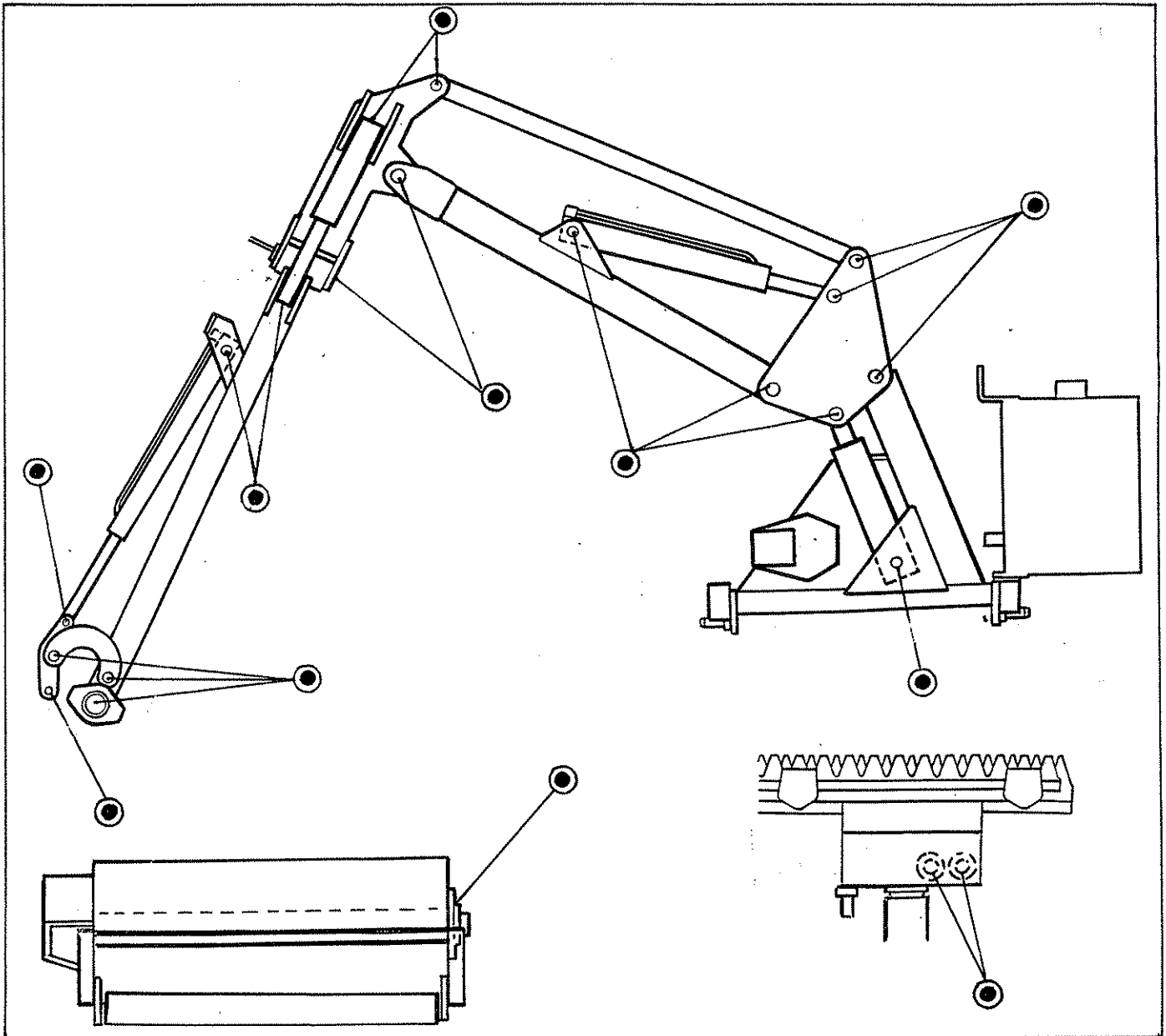

LUBRICATION

General

Grease daily all points shown. ●

Power take-off shaft

The P.T.O. shaft and its guards should be regularly examined. The universal joints should be greased very sparingly i.e. one shot weekly.

Note: Overgreasing a universal joint will blow-out the cork or neoprene sealing rings that exclude the dirt from the needle bearings inside.

The two halves of the plastic guard should be checked daily to ensure that they can spin freely on the shaft. The nylon slip rings which support the guard on the drive shaft should be lightly greased at weekly intervals.

The telescopic drive shaft should be similarly separated and grease applied to the internal shaft at approximately 100 hour intervals.

HYDRAULIC SYSTEM

Oil supply

Check the oil level in the reservoir daily.

No fixed time period can be quoted for oil changes as operating conditions and maintenance standards vary so widely. Burnt and scorched oil odours and the oil darkening and thickening are all signs of oxidation and indicate the oil should be changed.

Moisture which results from condensation can become entrapped in the oil and cannot be removed by filtration so that water contamination is progressive.

Contamination can be reduced by:-

- 1) Cleaning around the reservoir cap before removal, and keeping that area clean
- 11) Using clean containers when replenishing the system
- 111) Regular servicing of the filtration system

Filtration Maintenance

The machine is protected by a 125 micron suction strainer and a low pressure 10 micron full flow return line filter.

- 1) Suction strainer

The strainer is permanently fixed within the reservoir.

Should symptoms of pump cavitation or spongy intermittent operation occur the tank must be drained and flushed out with a suitable cleaning agent eg. clean diesel oil

- 111) Return Line Filter

The elements should be changed after the first 50 hours and thereafter at 500 hour intervals. It is important to note hours worked as if the filter becomes blocked an internal by-pass within the canister will operate and no symptoms of filter malfunction will occur to jog your memory.

P.T.O. GEARBOX

The gearbox oil should be changed every working year or at 600 hour intervals, whichever occurs first. On level ground gearbox should be filled until oil is visibly level with the lip of the filler plug aperture. Do not attempt to fill by removing the breather as the depth of tapped thread in the casing at this point is insufficient to allow repeated loosening and tightening of the breather plug.

The gearbox capacity is 700 millilitres (1 1/4 pint) use EP 90 gear oil.

HYDRAULIC HOSES

The condition of all hoses should be carefully checked during routine service of the machine. Hoses that have been chafed or damaged on their outer casing should be securely wrapped with waterproof adhesive tape to stop the metal braid from rusting. Hoses that have suffered damage to the metal braid should be changed at the earliest opportunity.

Hose replacement

- a. Replace one hose at a time to avoid the risk of wrong connections.
- b. When the hose is screwed to an additional fitting or union, use a second spanner on the union to avoid breaking both seals.
- c. Do not use joining compound on the threads.
- d. Avoid twisting the hose. Adjust the hose line to ensure freedom from rubbing or trapping before tightening hose end connections.

Before changing hoses study the installation these are carefully calculated to prevent hose damage during operation. Always replace hoses in exactly the same manner. This is especially important for the flail hoses where they must be crossed, upper to lower, at the dipper and head pivots.

Two hose clips are provided at either end of the large bore suction and return hoses. These should be positioned so that their worm drive barrels are opposed at 180 degrees to reduce the possibility of air entering the system. A stop tap is provided to enable the suction hose to be changed without draining the tank.

CABLES

The cables operate on a push/pull system with the spool centering springs always returning the spool to the neutral position when the handle is released.

Care should be taken during installation and operation to ensure that the cables are not trapped or kinked. Any abrasion or damage to the outer casing should be sealed with plastic insulation tape to avoid moisture penetrating.

No routine adjustment of the cables are necessary as they do not stretch. The threaded collar is correctly adjusted when the lever is in a vertical position in its housing allowing an equal amount of travel in either direction.

CAUTION

On no account should any attempt be made to lubricate the cables which are assembled with a special lubricant during manufacture.

NOTE

Take care to ascertain the correct cable connections on both the control unit and the valve in the event of cable replacement.

FLAILHEAD

Frequently inspect the rotor assembly for damaged or missing flails. Bolts and nuts securing the flails to the rotor should be regularly checked and kept tight. The correct torque setting for these locknuts is 135 Nm (100 lbf/ft). Use only the correct flail bolt and locking nut. Check the flail pivot bushes for possible damage or wear. They do not require oil.

Do not attempt to run the rotor with flails missing. Imbalance will cause severe vibration and can rapidly damage the rotor shaft bearings. As an emergency measure if a flail is broken off or lost, remove another on the opposite side of the rotor to retain balance. Always replace flails in opposite pairs and never match up a new flail with a re-sharpened one which will of course be lighter.

Blunt flails absorb a lot of power and leave an untidy finish to the work. They should be sharpened on a grindstone or with a portable grinder periodically.

Wear protective gear when sharpening flails.

Ensure that the bearing housings and hydraulic mounting nuts and bolts are kept tight. They should be checked during servicing.

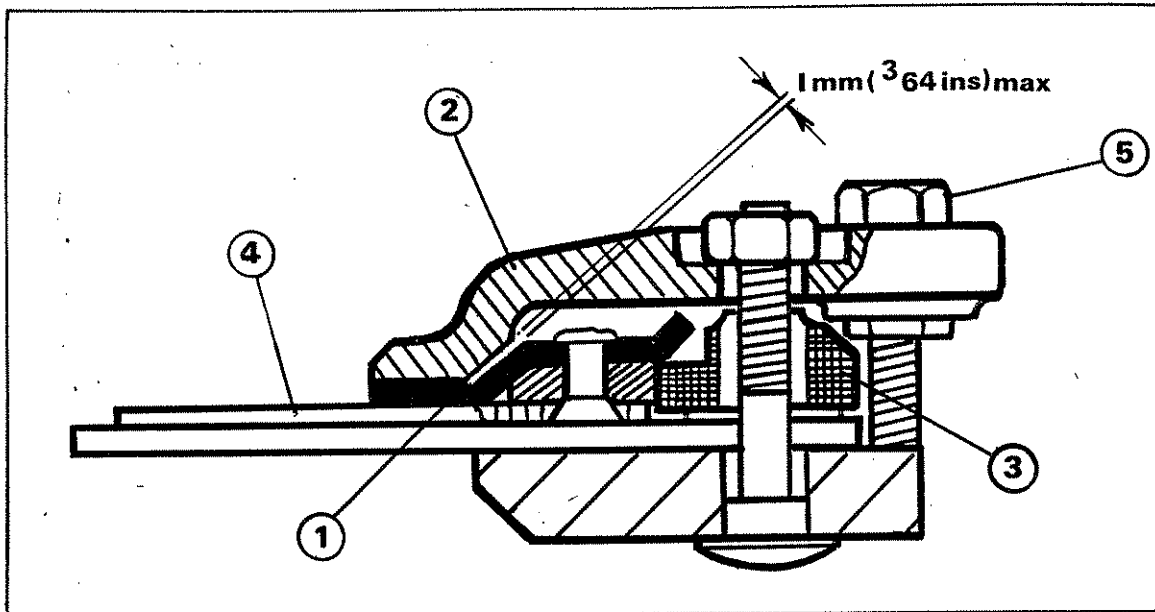

CUTTERBAR

Adjusting the knife guides

Before commencing any checks or adjustments lay the cutterbar flat on the ground. Select 'cutterbar off', switch off the tractor and disconnect the con rod.

When adjusted correctly the knife sections (4) lie flush between the fingers and the underside of the knife holder (1)

In addition there must be a maximum clearance of 1mm between the sloping faces of the knife holder (1) and the guide plate (2). This allows clearance for the knife to move freely and can be checked by placing a 5/8" dia bar into the con rod socket in the knife heel and operating by hand.

The guide plate (2) and rubbing plate (3) are mounted, through slotted holes which allow the correct lateral positioning of the knife in relation to the fingers.

Any play caused by wear between the knife holder (1) and the knife sections (4) is removed by turning the setscrew (5). The knife should be adjusted until the mating surfaces are flush. No downward pressure should be exerted onto the knife as this may impede its free movement.

Sharpening the knife

After five to twenty operating hours, depending on the work involved the knives require re-sharpening.

It is recommended that knives are removed from the cutterbar for resharpener.

Switch off tractor, disconnect the con rod, remove the three setscrews securing the knife heel to the knife and withdraw the knife from the cutterbar.

Clean the knife and ensure that neither the back nor the knife sections are bent. Straighten as necessary.

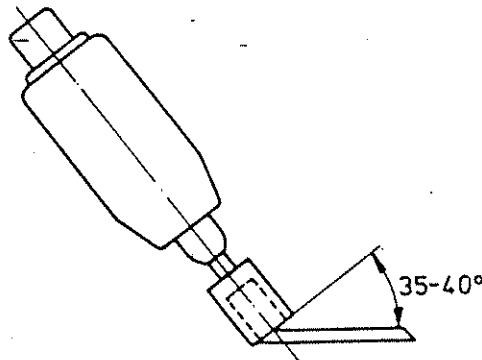

A cutting angle of 35 degrees - 40 degrees is required.

A high speed hand grinder should be used with ideally, a pot shaped pencil grinder of approximately 25mm (1") dia by 35mm (13/8) long. Grinding is carried out with the end face of the grinder moving from the base of the knife.

It is possible to re-sharpen the knives in situ. Position the cutterbar on or parallel to the ground. Switch off the tractor engine and disconnect the con-rod. Manually position the knives so that they cover the fingers and clamp together in this position.

Sharpening with files is not recommended as the process tends to leave small burrs on the edge which; when the knife is replaced will curl under, impede the free movement of the knife and leave a blunt cutting edge.

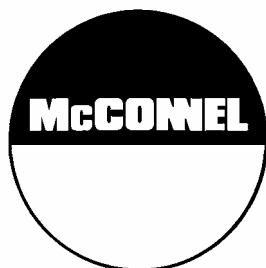

McConnel Limited, Temeside Works, Ludlow, Shropshire SY8 1JL. England.
Telephone: 01584 873131. Facsimile: 01584 876463. www.mcconnel.com