

Publication 178
July 1992

Serial No.

Part No.
75-50-850

PA 2050 SERIES

Operator handbook





EC DECLARATION OF CONFORMITY
conforming to EEC Directive 89/392/EEC

We,

McCONNEL LIMITED, Temeside Works, Ludlow,
Shropshire, SY8 1JL

declare under our sole responsibility that

the product (type) AXLE MOUNTED ARM FLAIL MOWERS

Product Code PASO, MAS2, MAB1, PAGO, MABO, PATO, MATO

Serial No. & Date

Type

Manufactured by the above Company/*

(*insert business name and full address if not stated above)

complies with the required provisions of the Directive 89/392/EEC,
and AMD 91/368/EEC, AMD 93/44/EEC, AMD 93/68/EEC and
conforms with European Norm. BS EN 292

Part 1:1991 Safety of Machinery - Terminology, methodology

Part 2:1991 Safety of Machinery - Technical specifications

and other national standards associated with its design and
construction as listed in the Technical File.

Signed J. A. Davies
on behalf of McCONNEL LIMITED

Responsible Person

Status. DIRECTOR OF ENGINEERING Date 8.12.94

EC DECLARATION OF CONFORMITY
conforming to EEC Directive 89/392/EEC

We,

McCONNEL LIMITED, Temeside Works, Ludlow,
Shropshire, SY8 1JL

declare under our sole responsibility that

the product (type) .. FLAIL HEADS ..

Product Code .. BD12, BD16, F110, F112, F115, F012, F016 ..

Serial No. & Date

Type

Manufactured by the above Company/* ..

(*insert business name and full address if not stated above)

complies with the required provisions of the Directive 89/392/EEC,
and AMD 91/368/EEC, AMD 93/44/EEC, AMD 93/68/EEC and
conforms with European Norm. BS EN 292

Part 1:1991 Safety of Machinery - Terminology, methodology
Part 2:1991 Safety of Machinery - Technical specifications

and other national standards associated with its design and
construction as listed in the Technical File.

Signed .. J. Davies ..
on behalf of McCONNEL LIMITED

Responsible Person

Status: DIRECTOR OF ENGINEERING .. Date .. 8.12.94 ..

LIST OF CONTENTS

MAIN FRAME PILLAR AND ARMS

Main Frames	Page 2
Pillar and rocker	Page 4
Main Arm	Page 6
Dipper - Std. arm	Page 8
Dipper - Tele arm	Page 10
Dipper - Midcut arm	Page 12
Control mounting	Page 14
Operator guard	Page 14
Catch assembly	Page 15

FLAIL HEADS

Flail head casing - 90 series	Page 16
Rotors and flails - 90 series	Page 20
Rollers - 90 series	Page 22

HYDRAULIC INSTALLATIONS

Hydraulic installation Cable std. arm	Page 24
Hydraulic installation Electric std. arm	Page 26
Hydraulic installation Cable tele arm	Page 28
Hydraulic installation Electric tele arm	Page 30
Hydraulic installation Midcut arm	Page 32

CONTROL VALVES

Main valve Cable std. arm	Page 34
Main valve Cable tele arm	Page 36
Lever controls - lift, reach and angle - cable machines	Page 38
Auxiliary control valve - cable machines	Page 40
Lever auxiliary controls - cable std. arm	Page 42
Lever auxiliary controls - cable tele. machines	Page 44
Main valve - Electric std. arm	Page 46
Main valve - Electric tele. arm	Page 48
Main valve - Midcut arm	Page 50
Slew valve All except midcut	Page 52
Park work and lift check valves - Midcut only	Page 54
Solenoids	Page 56
Switch box	Page 58

GENERAL HYDRAULICS

Pump	Page 60
Gearbox	Page 62
Rotor Control Valve - Cable std. arm	Page 64
Rotor control valve - Cable tele and electric machines	Page 66
Hydraulic tank	Page 68
Lift float kit	Page 70
Angle float kit - Extra for electric machines only	Page 72

HYDRAULIC RAM

Slew/breakaway ram	Page 74
Lift and reach ram	Page 75
Angle ram	Page 76
Tele ram Tele only	Page 77
Breakaway ram - Midcut only	Page 78

STICKERS

Cable std. arm	Page 80
Cable tele. arm	Page 82
Electric std. arm	Page 84
Electric tele. arm	Page 86
Midcut arm	Page 88
Sticker illustrations	Page 90

FOR NOTES

READ THE BOOK FIRST

It might save hours and pounds later

**When ordering spare parts always
quote the machine type and serial
number as well as the part number**

**Factory re-built service exchange
units of the major hydraulic components
are available from you dealer.**

NOISE

The equivalent daily personal noise exposure from this machine, measured at the operators' ear, is within the range 78 - 85 DB.

These figures apply to a normal distribution of use where noise fluctuates between zero and maximum. The figures assume that the machine is fitted to a tractor with a quiet cab with the windows closed in a generally open environment. We recommend that the windows are kept closed.

With the cab rear window open the equivalent daily personal noise exposure will increase to a figure within the range 82-88 DB.

At equivalent daily noise exposure levels of between 85 and 90 DB, ear protection is recommended, it should be used if any window is left open.

LIST OF CONTENTS

GENERAL INFORMATION.....	Page 1
INTRODUCTION.....	Page 2
SAFETY PRECAUTIONS	Page 3
FITTING.....	Page 9
TRACTOR REQUIREMENTS	Page 9
Minimum weights	Page 9
Min Hp	Page 9
Linkage.....	Page 9
PTO shaft.....	Page 10
TRACTOR PREPARATION.....	Page 10
Fitting operator guard.....	Page 10
Wheel width	Page 10
Ballast weight.....	Page 10
Lift links.....	Page 10
Fitting axle bracket/catches.....	Page 11
MACHINE PREPARATION.....	Page 12
ATTACHMENT TO TRACTOR	Page 13
FITTING CONTROL UNIT IN CAB.....	Page 16
OIL REQUIREMENTS	Page 17
RUNNING UP.....	Page 18
SETTING REACH STOP (Mid cut only)	Page 18
REMOVAL FROM TRACTOR	Page 19
STORAGE.....	Page 19

OPERATION.....	Page 20
CUTTING LIMITATIONS	Page 20
OPERATOR GUARD	Page 20
PREPARATION.....	Page 20
MACHINE CONTROLS AND LEVER FUNCTIONS	Page 20
Switch functions	Page 27
ROTOR CONTROLS.....	Page 27
MOVING INTO TRANSPORT POSITION	Page 28
TRANSPORT POSITION.....	Page 28
MOVING FROM TRANSPORT TO WORK POSITION	Page 29
ENGAGING DRIVE	Page 29
ROTOR OPERATING SPEED.....	Page 30
TRACTOR FORWARD SPEED.....	Page 30
HIGHWAY WORKING	Page 30
GENERAL WORKING PRACTISES	Page 31
BREAKAWAY	Page 31
WORKING ON ADVERSE SLOPES	Page 32
POWERED SLEW	Page 32
AUTO HEAD CONTROL.....	Page 32
TELESCOPIC DIPPER.....	Page 32
WIRE TRAP	Page 33
REMOVING WIRE.....	Page 33
OVERHEAD OBSTRUCTIONS.....	Page 33
HIGH VOLTAGE CABLES.....	Page 33
HEDGE CUTTING PROCEDURE	Page 34
Preliminary precautions.....	Page 34
Upward cutting	Page 34
Downward cutting	Page 34
Reversing rotation	Page 34
Cutting sequence.....	Page 35
GRASS CUTTING	Page 36
ROLLER POSITION.....	Page 37
LIFT FLOAT KIT (optional extra)	Page 38
HEAD ANGLE FLOAT KIT (Optional extra)	Page 39
MAINTENANCE.....	Page 40
LUBRICATION.....	Page 40
General.....	Page 40
P.T.O. shaft.....	Page 40
HYDRAULIC SYSTEM.....	Page 41
Oil supply.....	Page 41
Filtration.....	Page 41
FLAIL HEAD.....	Page 42
CABLES.....	Page 42
HYDRAULIC HOSES	Page 43
Hose replacement	Page 43
Hose warranty	Page 43
P.T.O. GEARBOX	Page 43
HOSE CONNECTIONS.....	Page 44

FOR NOTES

DELIVERY

The machine may be despatched in a partially dismantled state and will certainly be fitted with packing straps to ensure stability during transport.

Prior to attachment to the tractor the machine must be unpacked/re assembled into a position where it is standing on its legs/feet with the arms and head in a stable position with the head on the ground.

When doing this always carefully observe the following :-

Study carefully and note any dismantled or disconnected components.

Study the transport straps and determine what will happen if they are cut

Read the instruction book first to familiarise yourself with the machine.

Be aware that components are heavy and may cause injury if they fall onto or crash into any part of the body

Use overhead lifting equipment. Do not risk injury by lifting awkward or heavy objects.

Never struggle alone - ALWAYS SEEK ASSISTANCE.

Proceed one step at a time and ensure that the machine is stable and supported before moving on to the next operation.

If the machine requires tractor power to carry out the necessary work e.g. extending rams on electric machines, always operate these controls from within the cab and ensure the engine is switched off before leaving the tractor seat.

Always proceed with extreme caution, think carefully about the consequences of the next action and always remain aware of human vulnerability when working with heavy machinery.

GENERAL INFORMATION

Read this manual before fitting or operating the machine. If in doubt contact your dealer or the McConnell Service Department for assistance.

Use only McConnell spare parts on McConnell equipment and machines. Refer to the parts section before ordering spares.

DEFINITION

The following definitions apply throughout this manual:

WARNING

An operating procedure, technique etc., which can result in personal injury or loss of life if not observed carefully.

CAUTION

An operating procedure, technique etc., which can result in the damage of either machine or equipment if not observed carefully.

NOTE An operating procedure, technique etc., which is considered essential to emphasise.

LEFT AND RIGHT-HAND

This term is applicable to the machine when fitted to the tractor and viewed from the rear. This also applies to tractor references.

Record the serial number of your machine on this page and always quote this number when ordering spares. Whenever information concerning the machine is requested remember to also state the type of tractor to which it is fitted.	
MACHINE SERIAL NUMBER	INSTALLATION DATE
MODEL DETAILS	
DEALERS NAME	
DEALERS TELEPHONE NUMBER	

INTRODUCTION

ALL MODELS

- Axle mounted
- Right or left hand cut
- Hedge or grass
- Fully independent hydraulics,54 Hp at PTO
- Operator gaurd
- 44 imp gall. (200 ltr.) hydraulic reservoir
- Independent reversible rotor on/off valve
- Hydraulic breakaway
- 97 degrees slew

PA 2050 Cable

- Cable controls
- 1.2 or 1.6 metre flail head

PA 2050 E

- Electric controls
- 1.2 or 1.6 metre flail head

PA 2050 E - AHC

- Electric controls
- 1.2 or 1.6 metre flail head
- Auto head control

PA 2050 E - Telescopic

- Electric controls
- 1.2 metre flail head
- 1.05 metre extra reach

PA 2050 E - Telescopic - AHC

- Electric controls
- 1.2 metre flailhead
- Auto head control
- 1.05 metre extra reach

PA 2050 E - Mid cut

- Electric controls
- 1.2 or 1.6 metre flail head
- 1.0 metre forward extension

PA 2050 E - Mid cut - AHC

- Electric controls
- 1.2 or 1.6 metre flail head
- 1.0 metre forward extension
- Auto head control

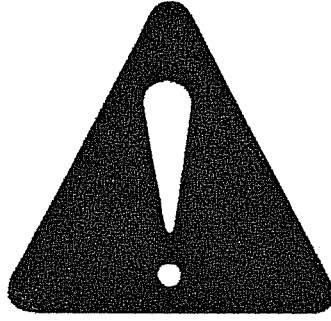

SAFETY INFORMATION

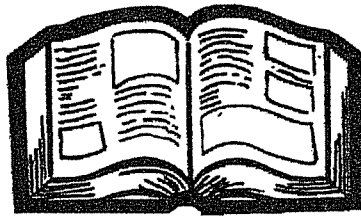

This machine has the potential to be extremely dangerous, in the wrong hands it can kill or maim. It is therefore imperative that the owner, and the operator of this machine, read the following section to ensure that they are both fully aware of the dangers that do, or may exist, and their responsibilities surrounding its use.

The operator of this machine is responsible not only for their own safety but equally for the safety of others who may come into the close proximity of the machine, as the owner you are responsible for both.

POTENTIAL SIGNIFICANT DANGERS ASSOCIATED WITH THE USE OF THIS MACHINE:

- *Being hit by debris thrown by rotating components.*
- *Being hit by machine parts ejected through damage during use.*
- *Being caught on a rotating power take-off (PTO) shaft.*
- *Being caught in other moving parts i.e.: belts, pulleys and cutting heads.*
- *Electrocution from Overhead Power Lines (by contact with or 'flashover' from).*
- *Being hit by cutting heads or machine arms as they move.*
- *Becoming trapped between tractor and machine when hitching or unhitching.*
- *Tractor overbalancing when machine arm is extended.*
- *Injection of high-pressure oil from hydraulic hoses or couplings.*
- *Machine overbalancing when freestanding (out of use).*
- *Road traffic accidents due to collision or debris on the road.*

BEFORE USING THIS MACHINE YOU MUST:

- *Ensure you read all sections of the operator handbook.*
- *Ensure the operator is, or has been, properly trained to use the machine.*
- *Ensure the operator has been issued with and reads the operator handbook.*
- *Ensure the operator understands and follows the instructions in operator handbook.*
- *Ensure the tractor front, rear and side(s) are fitted with metal mesh or polycarbonate guards of suitable size and strength to protect the operator against thrown debris or parts.*
- *Ensure tractor guards are fitted correctly, are undamaged and kept properly maintained.*
- *Ensure that all machine guards are in position, are undamaged, and are kept maintained in accordance with the manufacturer's recommendations.*
- *Ensure flails and their fixings are of a type recommended by the manufacturer, are securely attached and that none are missing or damaged.*
- *Ensure hydraulic pipes are carefully and correctly routed to avoid damage by chaffing, stretching or pinching and that they are held in place with the correct fittings.*
- *Always follow the manufacturer's instructions for attachment and removal of the machine from the tractor.*
- *Check that the machine fittings and couplings are in good condition.*
- *Ensure the tractor meets the minimum weight recommendations of the machine manufacturer and that ballast is used as necessary.*
- *Always inspect the work area thoroughly before starting to note obstacles and remove wire, bottles, cans and other debris.*
- *Use clear suitably sized warning signs to alert others to the nature of the machine working within that area. Signs should be placed at both ends of the work site. (It is recommended that signs used are of a size and type specified by the Department of Transport and positioned in accordance with their and the Local Highways Authority guidelines).*
- *Ensure the operator is protected from noise. Ear defenders should be worn and tractor cab doors and windows must be kept closed. Machine controls should be routed through proprietary openings in the cab to enable all windows to be shut fully.*
- *Always work at a safe speed taking account of the conditions i.e.: terrain, highway proximity and obstacles around and above the machine.*
- *Extra special attention should be applied to Overhead Power Lines. Some of our machines are capable of reach in excess of 8 metres (26 feet) this means they have the potential to well exceed, by possibly 3 metres (9' 9"), the lowest legal minimum height of 5.2 metres from the ground for 11,000 and 33,000 volt power lines. It cannot be stressed enough the dangers that surround this capability, it is therefore vital that the operator is fully aware of the maximum height and reach of the machine, and that they are fully conversant with all aspects regarding the safe minimum distances that apply when working with machines in close proximity to Power Lines. (Further information on this subject can be obtained from the Health & Safety Executive or your Local Power Company).*
- *Always disengage the machine, kill the tractor engine, remove and pocket the key before dismounting for any reason.*

- *Always clear up all debris left at the work area, it may cause hazard to others.*
- *Always ensure when you remove your machine from the tractor that it is left in a safe and stable position using the stands and props provided and secured if necessary.*

WHEN NOT TO USE THIS MACHINE:

- *Never attempt to use this machine if you have not been trained to do so.*
- *Never uses a machine until you have read and understood the operator handbook, are familiar with, and practiced the controls.*
- *Never use a machine that is poorly maintained.*
- *Never use a machine if guards are missing or damaged.*
- *Never use a machine on which the hydraulic system shows signs of wear or damage.*
- *Never fit, or use, a machine on a tractor that does not meet the manufacturer's minimum specification level.*
- *Never use a machine fitted to a tractor that does not have suitable front, rear and side(s) cab guarding made of metal mesh or polycarbonate.*
- *Never use the machine if the tractor cab guarding is damaged, deteriorating or badly fitted.*
- *Never turn a machine cutting head to an angle that causes debris to be ejected towards the cab.*
- *Never start or continue to work a machine if people are nearby or approaching - Stop and wait until they are at a safe distance before continuing.*
- *Never attempt to use a machine on materials in excess of its capability.*
- *Never use a machine to perform a task it has not been designed to do.*
- *Never operate the tractor or machine controls from any position other than from the driving seat, especially whilst hitching or unhitching the machine.*
- *Never carry out maintenance of a machine or a tractor whilst the engine is running – the engine should be switched off, the key removed and pocketed.*
- *Never leave a machine unattended in a raised position – it should be lowered to the ground in a safe position on a level firm site.*
- *Never leave a tractor with the key in or the engine running.*
- *Never carry out maintenance on any part or component of a machine that is raised unless that part or component has been properly substantially braced or supported.*
- *Never attempt to detect a hydraulic leak with your hand – use a piece of cardboard.*
- *Never allow children near to, or play on, a tractor or machine under any circumstances.*

ADDITIONAL SAFETY ADVICE

TRAINING

Operators need to be competent and fully capable of operating this machine in a safe and efficient way prior to attempting to use it in any public place. We advise therefore that the prospective operator make use of relevant training courses available such as those run by the Agricultural Training Board, Agricultural Colleges, Dealers and McConnel.

WORKING IN PUBLIC PLACES

When working in public places such as roadsides, consideration should be paid to others in the vicinity. Stop the machine immediately when pedestrians, cyclists and horse riders etc. pass. Restart only when they are at a distance that causes no risk to their safety.

WARNING SIGNS

It is advisable that any working area be covered by suitable warning signs and statutory in public places. Signs should be highly visible and well placed in order to give clear advanced warning of the hazard. Contact the Department of Transport or your Local Highways Authority to obtain detailed information on this subject. The latter should be contacted prior to working on the public highway advising them of the time and location of the intended work asking what is required by way of signs and procedure. – *'Non-authorized placement of road signs may create offences under the Highways Act'*.

SUGGESTED WARNING SIGNS REQUIRED

"Road works ahead" warning sign with a supplementary "Hedge cutting" plate. "For 1 mile" or appropriate shorter distance may be added to the plate.

"Road narrows" warning sign with supplementary "Single file traffic" plate.

White on blue "Keep right" () arrow sign on rear of machine.*

** Note – this applies to UK Market machines where traffic passes to the right of a machine working in the same direction as the traffic flow. The direction, use and colour of the arrow sign will depend on the country of use and the Local Highway Authorities regulations in the locality.*

USE OF WARNING SIGNS

- *On two way roads one set of signs is needed facing traffic in each direction.*
- *Work should be within 1 mile of the signs.*
- *Work only when visibility is good and at times of low risk e.g.: NOT during 'rush-hour'.*
- *Vehicles should have an amber flashing beacon.*
- *Ideally, vehicles should be conspicuously coloured.*
- *Debris should be removed from the road and path as soon as practicable, and at regular intervals, wearing high visibility clothing and before removing the hazard warning signs.*
- *Collect all road signs promptly when the job is completed.*

Although the information given here covers a wide range of safety subjects it is impossible to predict every eventuality that can occur under differing circumstances whilst operating this machine. No advice given here can replace 'good common sense' and 'total awareness' at all times but will go a long way towards the safe use of your McConnel machine.

VEHICLE/ TRACTOR PREPARATION

We recommend vehicles are fitted with cabs using safety glass windows and protective guarding when used with our machines.

Fit Operator Guard (part no. 73 13 324) using the hooks provided. Shape mesh to cover all vulnerable areas.

Remember the driver must be looking through mesh and/or polycarbonate glazing when viewing the flail head in any working position - unless the vehicle/ cab manufacturer can demonstrate that the penetration resistance is equivalent to, or higher than, that provided by mesh/polycarbonate glazing. If the tractor has a roll bar only, a frame must be made to carry both mesh and polycarbonate glazing. The operator should also use personal protective equipment to reduce the risk of serious injury such as; eye protection (mesh visor to EN1731 or safety glasses to EN166), hearing protection to EN352, safety helmet to EN297, gloves, filter mask and high visibility clothing.

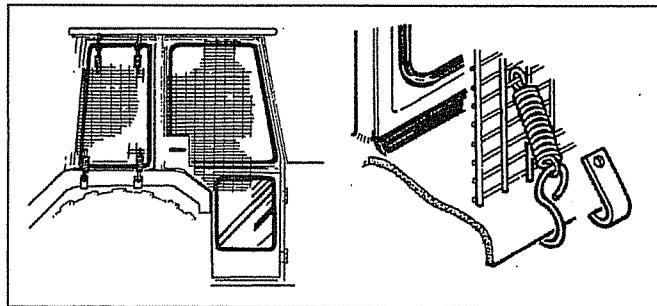

Vehicle Ballast: It is imperative when attaching 'third-party' equipment to a vehicle that the maximum possible stability of the machine and vehicle combination is achieved – this can be accomplished by the utilisation of 'ballast' in order to counter-balance the additional equipment added.

Front weights may be required for rear mounted machines to place 15% of total outfit weight on the front axle for stable transport on the road and to reduce 'crabbing' due to the drag of the cutting unit when working on the ground.

Rear weights may be required to maintain a reasonable amount of rear axle load on the opposite wheel from the arms when in work; for normal off-ground work i.e. hedge cutting this should be 20% of rear axle weight or more for adequate control, and for ground work i.e. verge mowing with experienced operators, this can be reduced to 10%.

All factors must be addressed in order to match the type and nature of the equipment added to the circumstances under which it will be used – in the instance of Power Arm Hedgecutters it must be remembered that the machines centre of gravity during work will be constantly moving and will differ from that during transport mode, therefore balance becomes critical.

Factors that effect stability:

- Centre of gravity of the tractor/machine combination.
- Geometric conditions, e.g. position of the cutting head and ballast.
- Weight, track width and wheelbase of the tractor.
- Acceleration, braking, turning and the relative position of the cutting head during these operations.
- Ground conditions, e.g. slope, grip, load capability of the soil/surface.
- Rigidity of implement mounting.

Suggestions to increase stability:

- Increasing rear wheel track; a vehicle with a wider wheel track is more stable.
- Ballasting the wheel; it is preferable to use external weights but liquid can be added to around 75% of the tyre volume – water with anti-freeze or the heavier Calcium Chloride alternative can be used.
- Addition of weights – care should be taken in selecting the location of the weights to ensure they are added to a position that offers the greatest advantage.
- Front axle locking, check with tractor manufacturer.

The advice above is offered as a guide for stability only and is not a guide to vehicle strength. It is therefore recommended that you consult your vehicle manufacturer or local dealer to obtain specific advice on this subject, additionally advice should be sought from a tyre specialist with regard to tyre pressures and ratings suitable for the type and nature of the machine you intend to fit.

P.T.O. DRIVE SHAFT SAFETY PRECAUTIONS

DANGER ON EACH TRACTOR CHECK:-



All machines

Ensure the correct end of the drive shaft is fitted to the tractor.. See labels on the drive shaft.

Check carefully that the drive shaft does not bottom out and that a minimum of 6" (150mm) of engagement is maintained.

Ensure that the guards are always in position, can rotate freely and the check chains are not stretched when the machine is raised or lowered.

Check that when in the continuous working position the drive shaft is not at an angle of more than 20 degrees to the P.T.O. centre line.

Ensure the drive shaft does not foul the tractor P.T.O. guard, the gearbox input shield or the tractor drawbar.

FITTING

TRACTOR REQUIREMENTS

Minimum tractor weights including ballast weight if necessary

PA 2050 Cable	}	3500 Kg
PA 2050 E		
PA 2050 E - AHC		

PA 2050 E Telescopic	}	3750 Kg
PA 2050 E Telescopic - AHC		
PA 2050 Midcut		
PA 2050 Mid cut - AHC		

Min Hp requirements

All models - 60 Hp

Linkage

Category II

PTO shaft

Tractor must be equipped with a live drive PTO to enable forward motion to be stopped while the flail head continues to operate.

TRACTOR PREPARATION

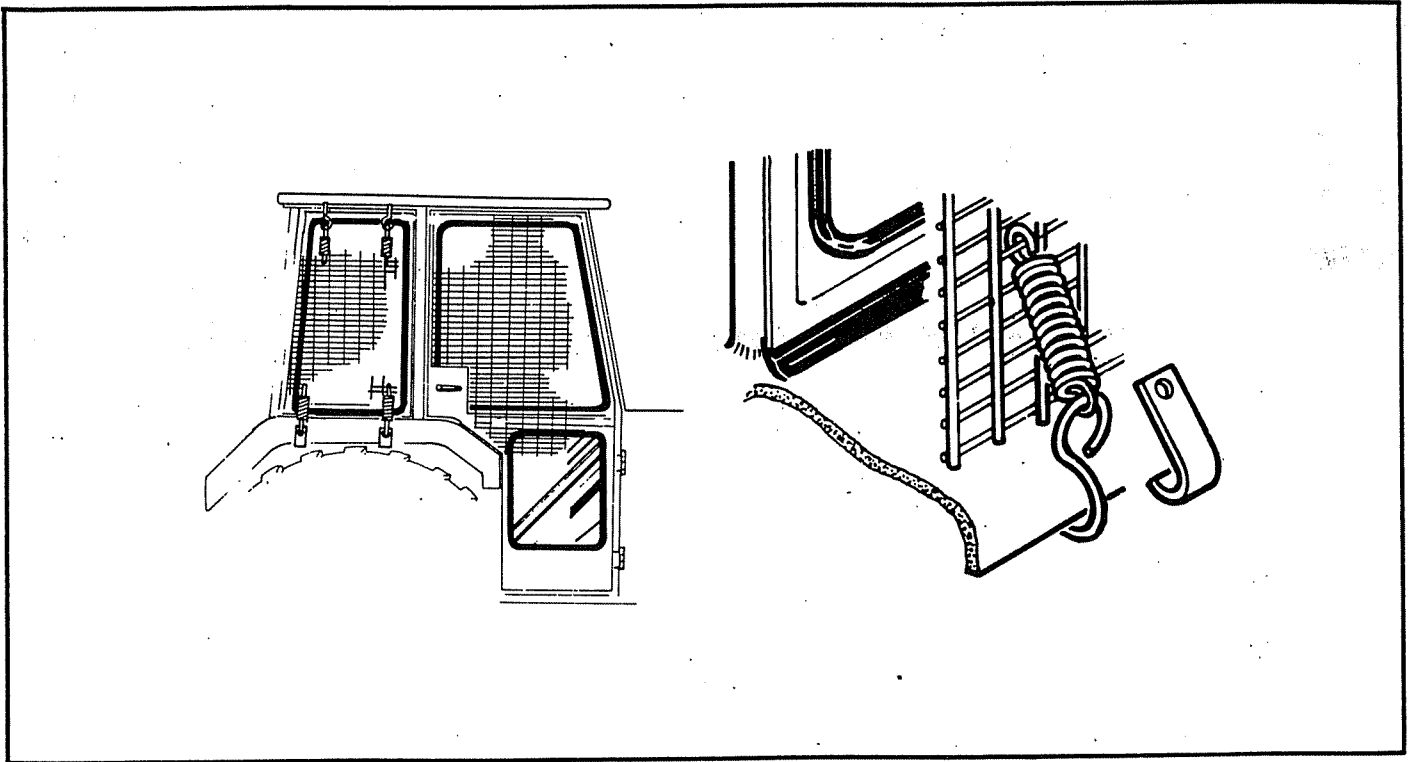

Fitting operator guard.

Use tractor with safety glass windows if possible and fit operator guard Part No. 73 13 324 using the hooks provided.

Shape mesh to cover all vulnerable areas. Remember the driver **must** be looking through mesh at the flail hed in **any** working position.

If windows are not laminated safety glass polycarbonate glazing must also be fitted.

If tractor has a roll bar only a frame must be made to carry both mesh and polycarbonate glazing.

Wheel width

Set wheel widths as wide as possible.

Ballast weight.

Add ballast weight whenever necessary within tractor manufacturers recommended limits to ensure stability under all working conditions.

Lift links

Adjust lift links until they are equal length.

Fitting axle bracket/catch assemblies.

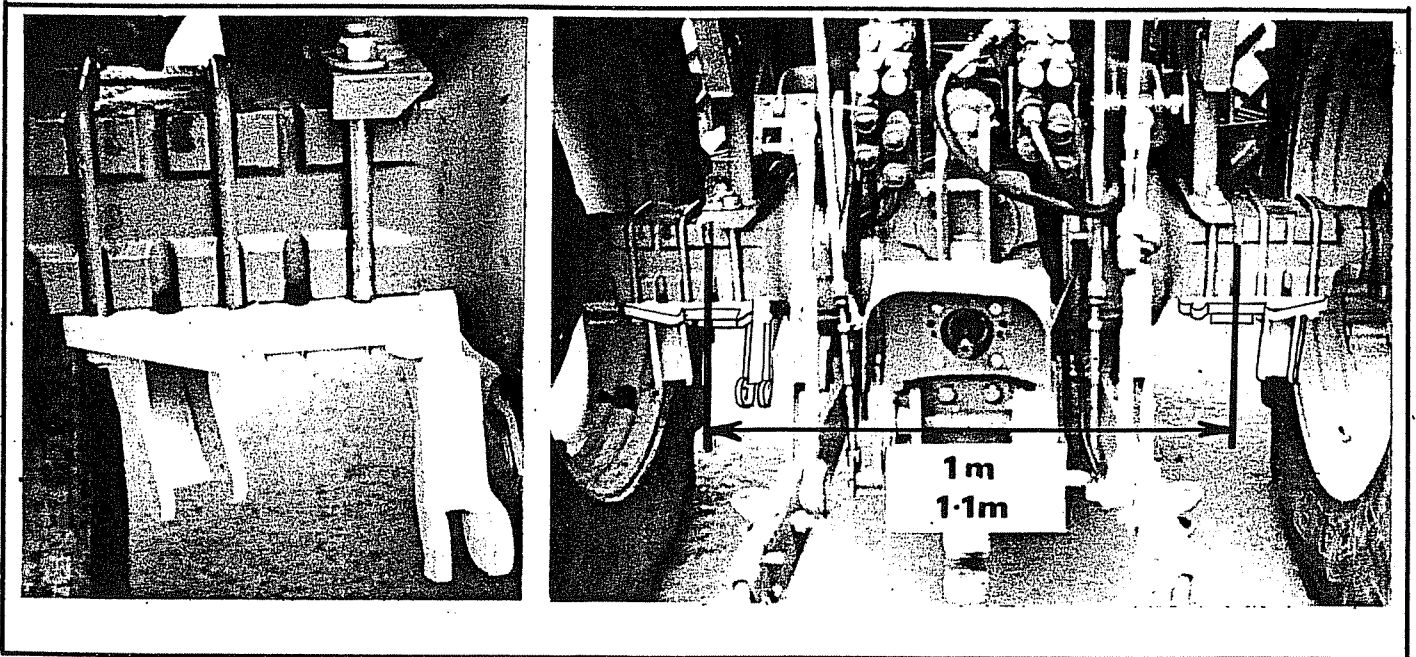

Bolt axle plates to the tractors axle either 1m or 1.1m apart. It may be necessary to remove the tractors check chain and/or assister ram brackets. If so the axle plate will include replacement brackets for these functions.

follow exactly the instructions in the separate axle bracket fitting sheet for your specific tractor. If you have not received it obtain one from your dealer **before commencing.**

Replace assister ram/s if fitted

Hook the catch assemblies onto the rear of the axle plates. Push firmly against the plate and vigorously pivot the catch forward and up until the spring loaded hook snaps into position.

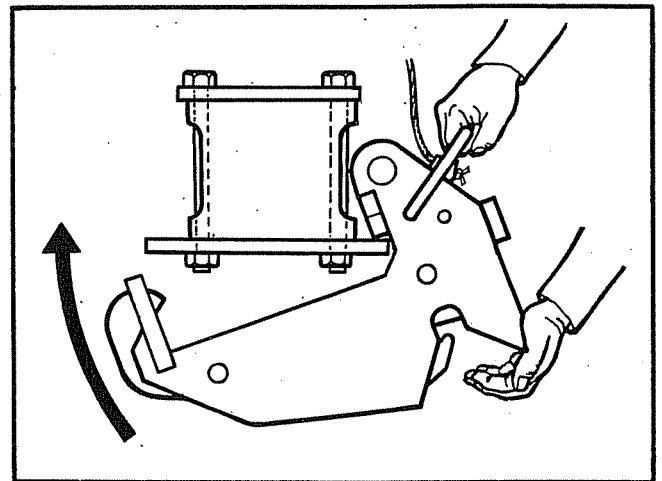

Pass the release cords into the cab.

MACHINE PREPARATION

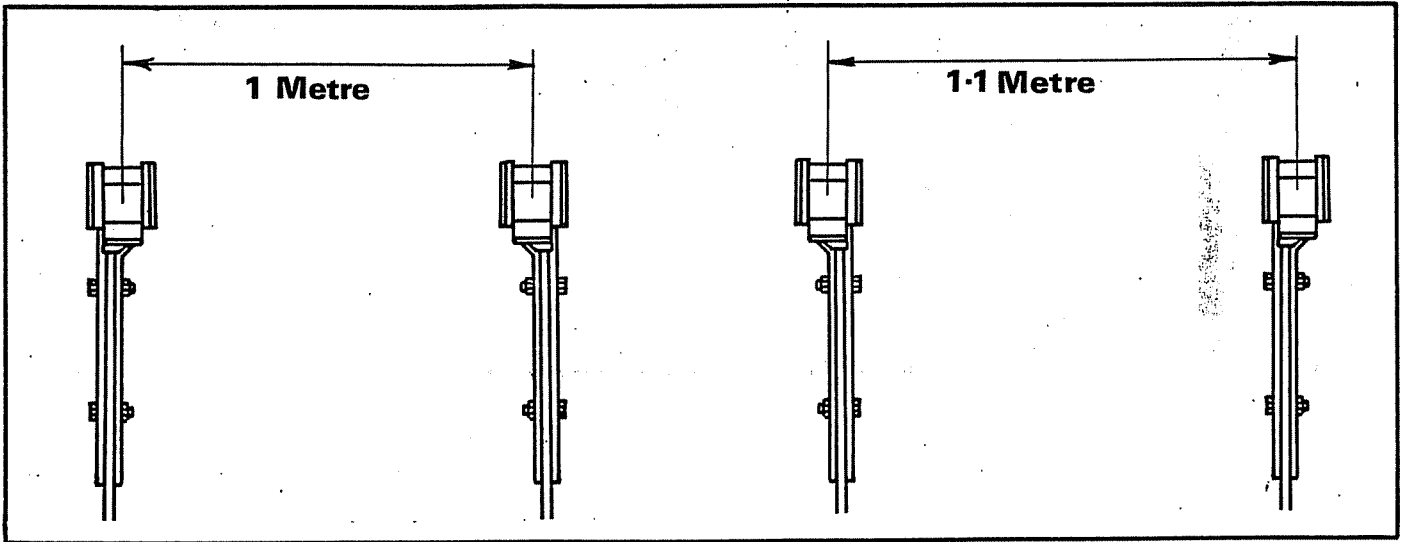

Position latch arms to match the width of the catches on the tractor.

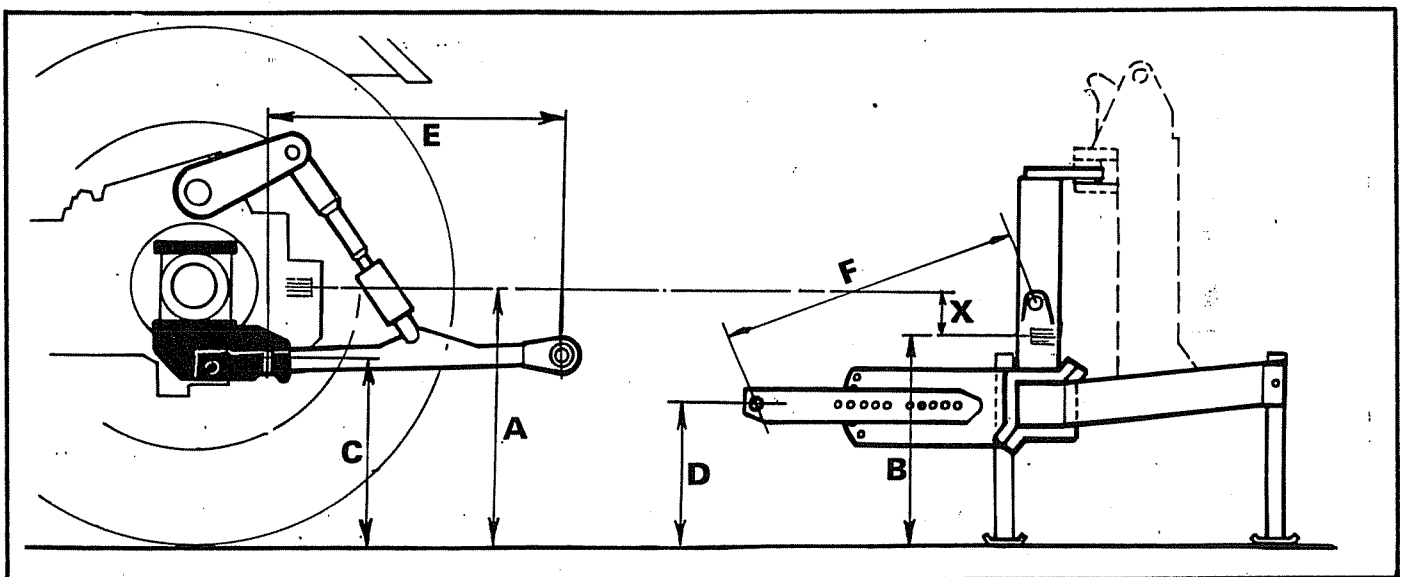

With frame vertical

Measure dimensions A and B. Subtract B from A to leave measurement 'X'.

Measure dimension 'C'

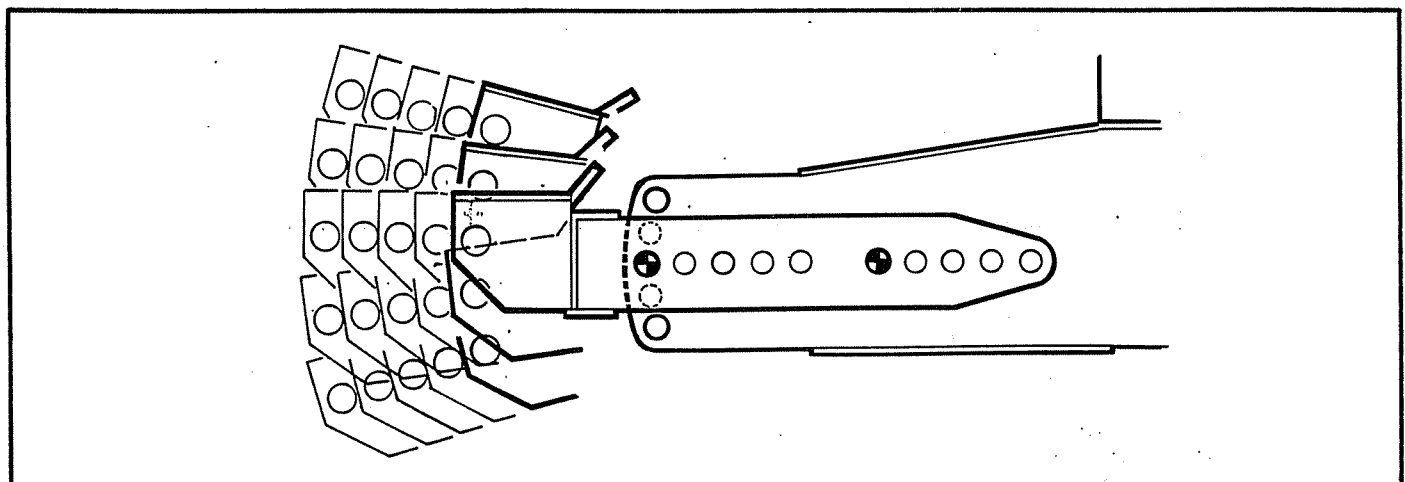

Select mounting holes to position latch arms so that dimension D equals dimension C minus measurement X and also when the draft link is horizontal and the rocking draft pin is in the upright position dimensions E and F are equal.

ATTACHMENT TO TRACTOR

Machine must stand on its legs with arms and head to the rear and with head on the ground.

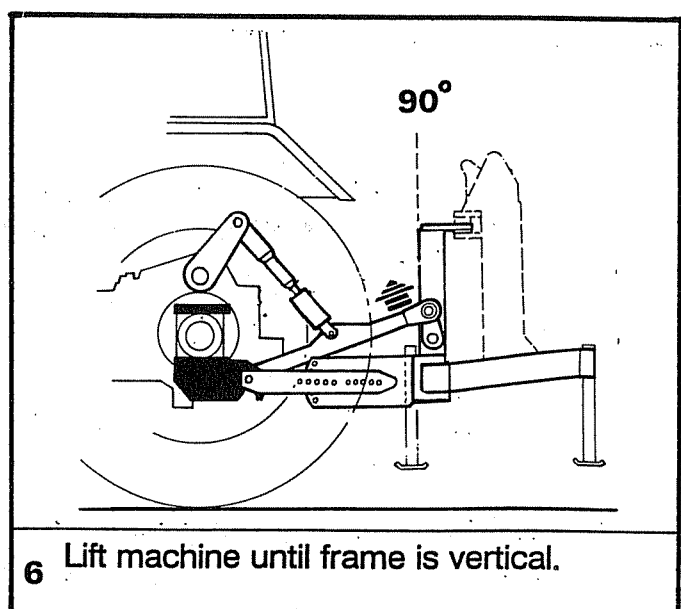
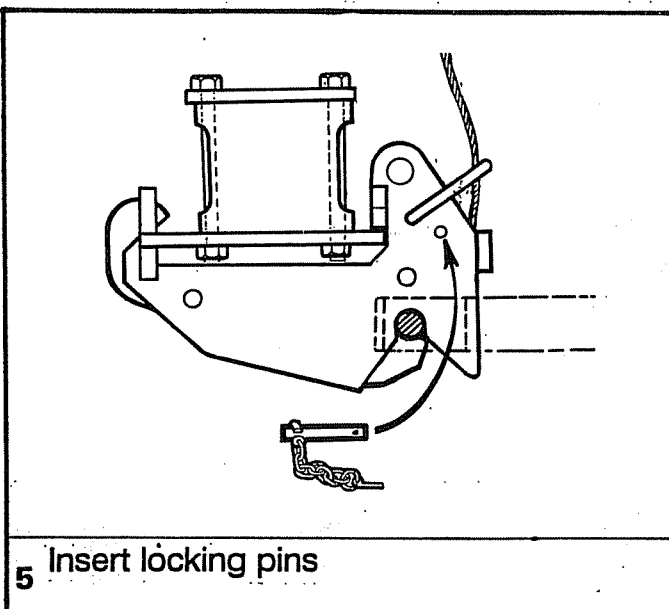
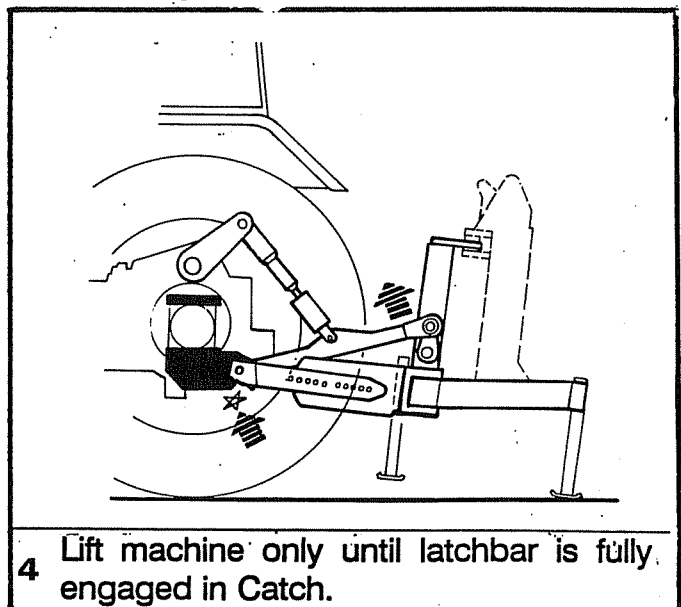
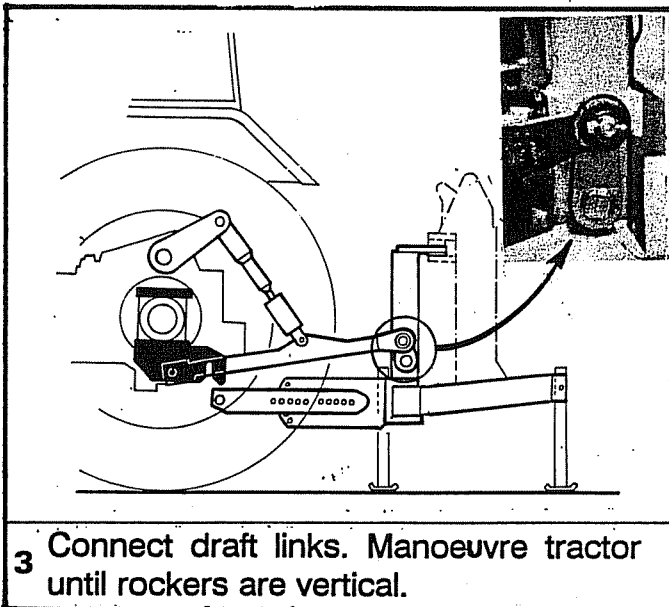
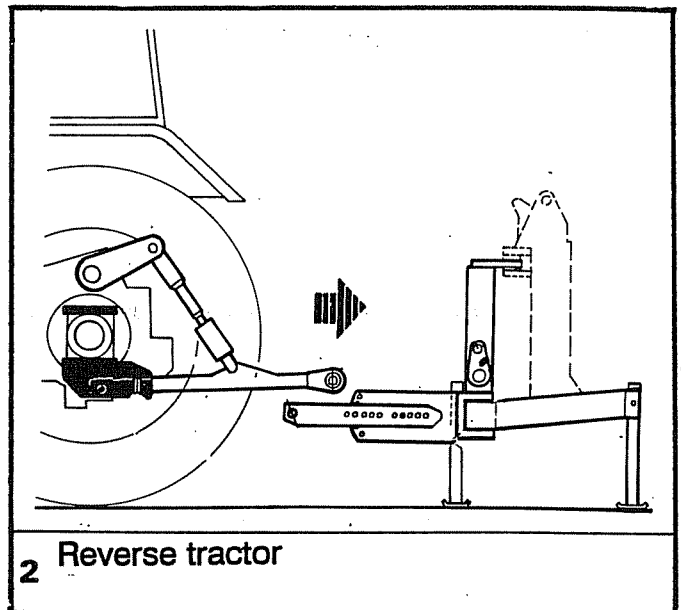
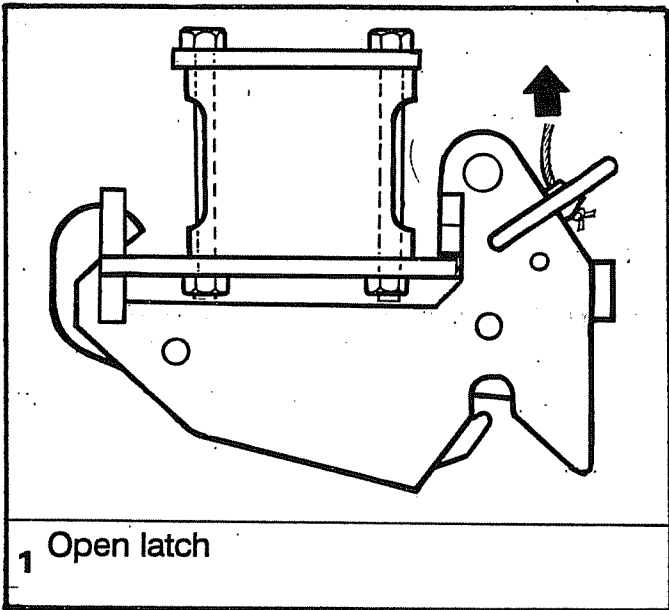

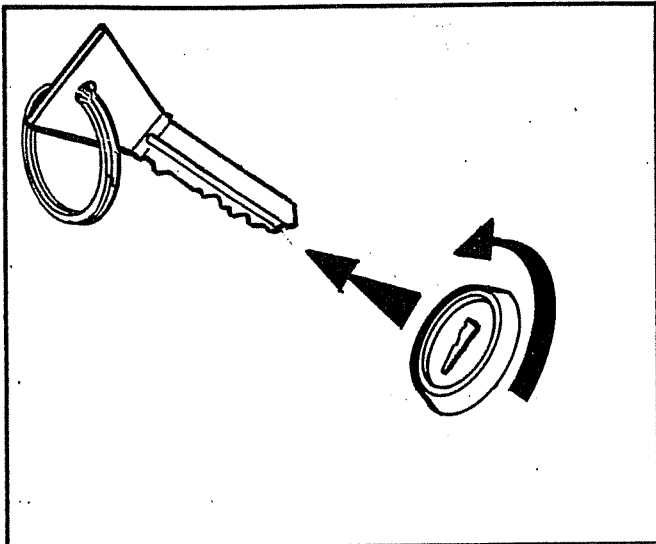

7 Switch off tractor

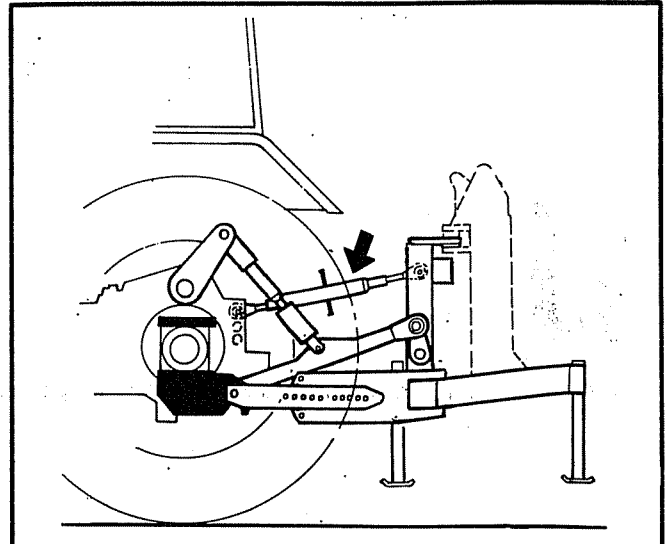

8 Fit top link. See Instruction Supplement 202 included in machine delivery pack.

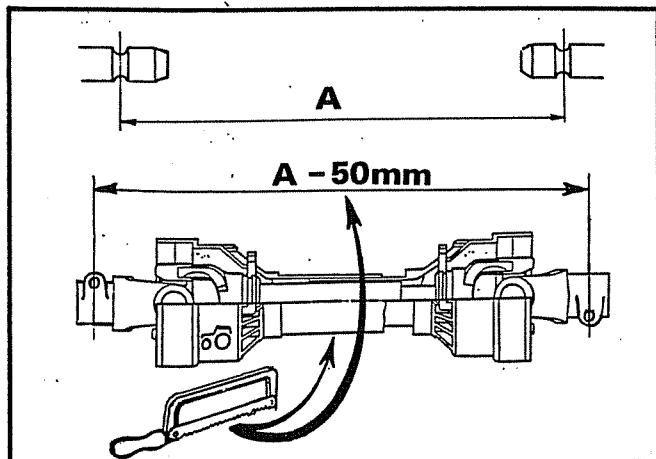

Measure 'A'

9 Cut PTO shaft, equal amounts off both halves, to measure A minus 50 mm. When fully closed.

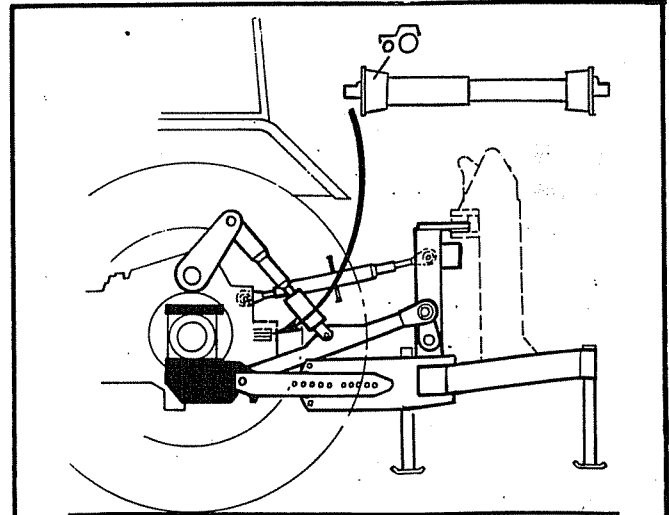

10 Fit PTO shaft

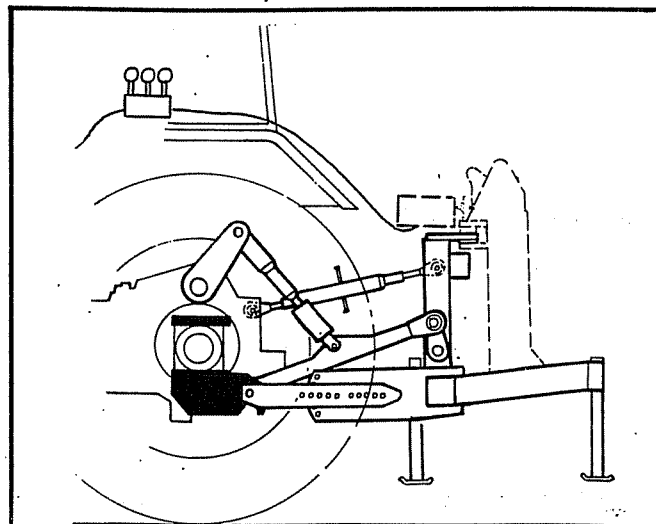

11 Fit controls in cab. See page 16

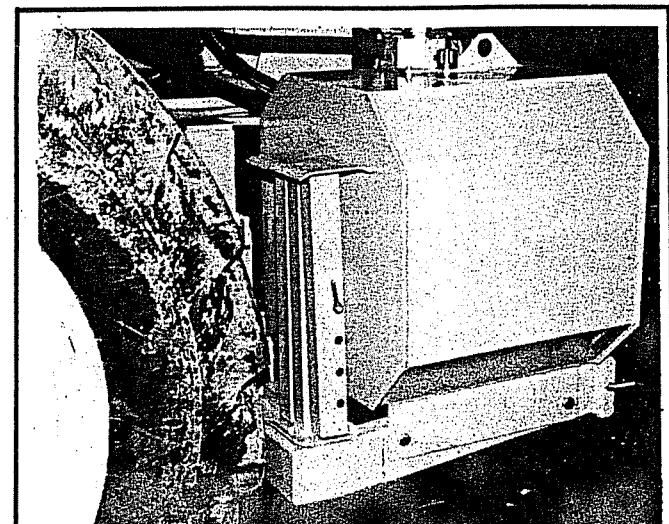

12 Stow legs.

FITTING CONTROL UNIT IN CAB Electric controlled models only

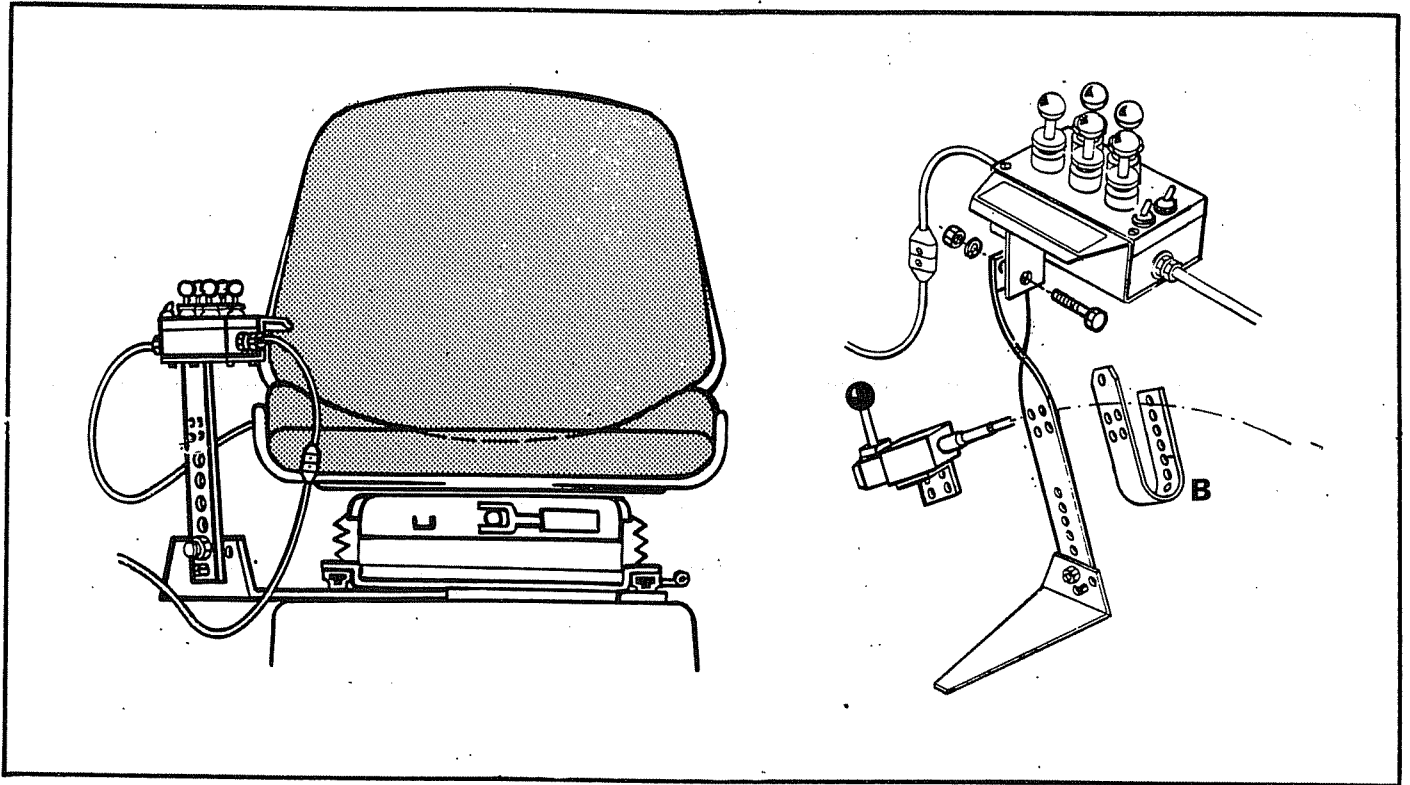

A bracket is clamped between the seat runners and their mounting base. Attached to this is a stalk which carries the control units. Modification to either may be necessary to achieve a comfortable working position.

On tractors other than the quiet cab models the stalk can be bent and bolted to the mudwing or the cladding of the cab ensuring that no structural member of the safety frame is drilled. See 'B'.

The supply cable should be connected to the tractors fuse box or the ignition switch where it can be switched off with the isolation key.

The control is 12 V dc. operated; the brown lead is Positive and the blue is Negative.

The 'Rotor' control lever is then bolted into position on the mounting stalk. When installing do not bend the cable tighter than 8 inch (200mm) radius.

FITTING CONTROL UNIT IN CAB - Cable controlled models only

A bracket is clamped between the seat runners and their mounting base. Attached to this is a stalk which carries the control units. Modification to either may be necessary to achieve a comfortable working position.

On tractors other than the quiet cab models the stalk can be bent and bolted to the mudwing or the cladding of the cab ensuring that no structural member of the safety frame is drilled.

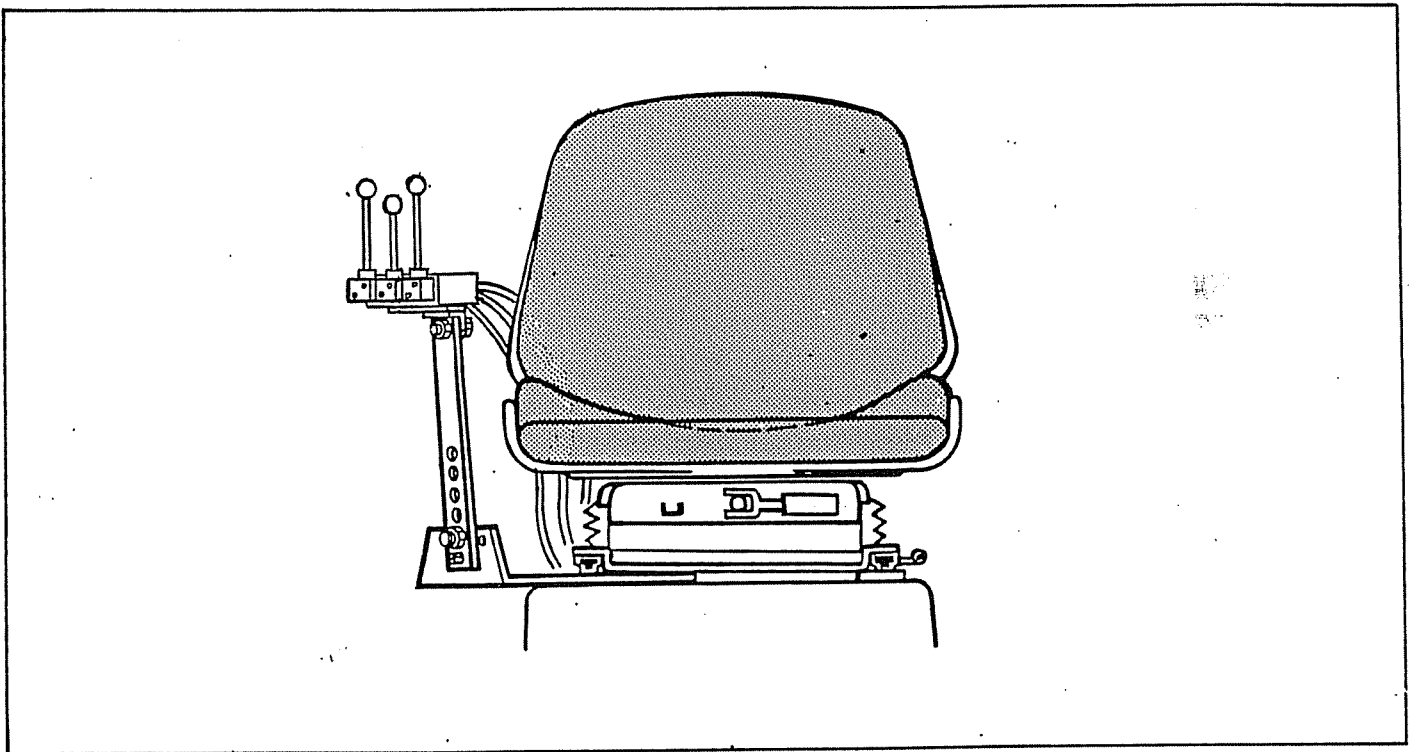

The control unit for Lift, Reach and angle is bolted to an angled mounting bracket in either a transverse or longitudinal position thus giving a variety of mounting positions, which in conjunction with the flexibility of the mounting pillar will enable a satisfactory working position to be achieved.

The auxiliary control units are bolted to the tractor in a convenient location ensuring that no structural member is used.

In deciding the final position of the control box remember not to exceed the minimum acceptable bend radii of 8" for the cables.

The handles may be screwed into alternative holes in the levers to give an 'in line' installation should it be desirable.

OIL REQUIREMENTS

Tank

Fill the reservoir to the centre of the sight tube. The capacity is approximately 40 galls imp (182 litres). Enduro tank is 44 galls imp. (200 ltrs.)

Do not overfill

Supplier	Cold or temperate climate	Hot climate
Castrol	Agricastrol hydraulic oil Hy-spin AWS32	Hy- spin AWS68
Shell	Tellus 27	Tellus 33
Mobil	D.T.E. 25	D.T.E. 26
Esso	Nuto 'H' or 'A' 32	Nuto 'H' or 'A' 68
Texaco	Rando HD 32	Rando D 68
Gulf	Hydrasil 32	Hydrasil 68
B.P.	Energal HLP 32	Energal HLP 68
Dalton	Silkolene Dove 32 or Derwent 32	Silkolene Dove 68 or Derwent 68
Elf	Hydrelf 32	Hydrelf 68

Gearbox

Check the gearbox oil level. On level ground gearbox should be filled until oil dribbles out of the level plug. Top up if required with SAE 30/50 Universal tractor oil.

RUNNING UP PROCEDURE

Ensure the suction hose tap is **OPEN** and the rotor control is in '**STOP**' position, start tractor, engage P.T.O. allow the oil to circulate for about 5 minutes before operating the arms.

Operate the arms through their complete range ensuring that all movements are functioning correctly.

Check that flail nuts and bolts are tight. Place the flail head in a safe attitude and move the rotor control to '**START**' position. After initial fluctuation the rotor should settle to a steady speed. Increase P.T.O. speed to approximately 360 rpm. and run for a further five minutes before disengaging and stopping tractor.

Check the hose runs and observe that they are free from any pinching, chafing straining or kinks.

Re-check the oil level in the tank and top up as necessary.

SETTING REACH STOP Mid cut only

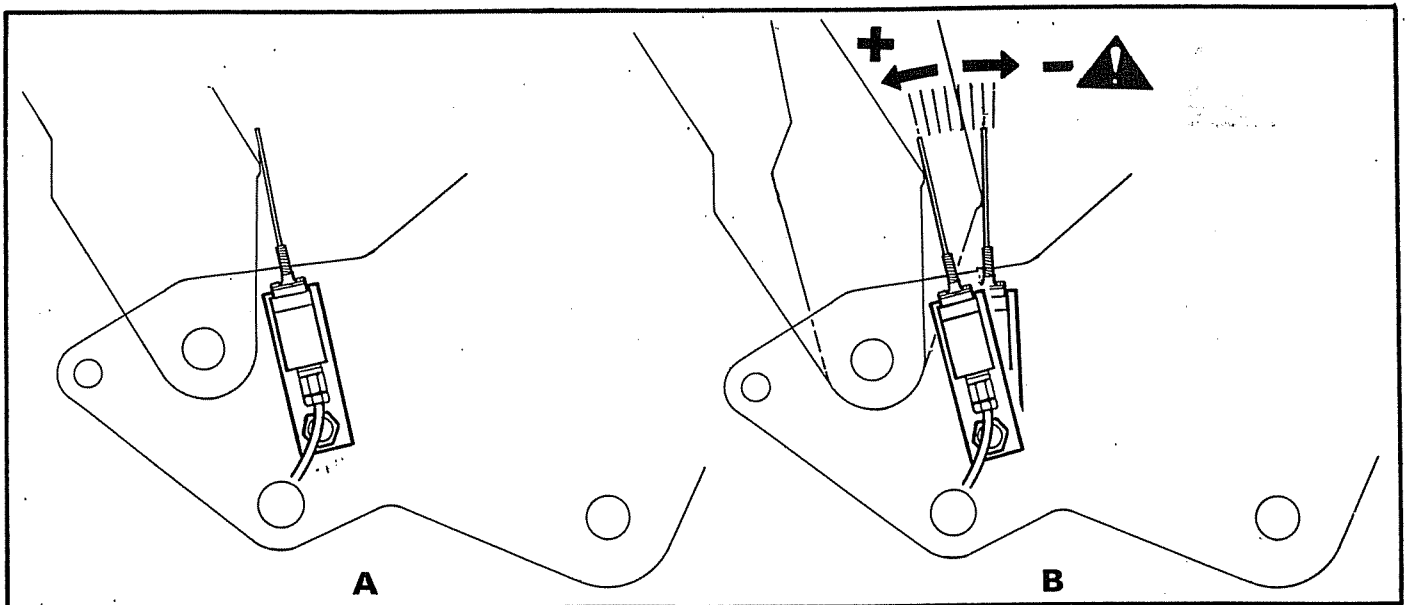

The machine has a '**Reach**' stop switch to prevent the dipper arm hitting the cab. When despatched it is mounted to give a generous cab clearance. **See A**

With "**Work**" selected the switch can be pivoted away from the main arm to allow the flail head to cut closer to the tractor. **See B. Allow 200 mm minimum cab clearance.**

Move switch antenna 5mm only and test with the '**Lift**' fully raised. Repeat if necessary until the required clearance is achieved.

WARNING

Do not remove the '**Reach**' stop Switch.

If the tractor is changed go back to maximum clearance position then reset as above if required.

REMOVAL FROM TRACTOR

Select a firm level site

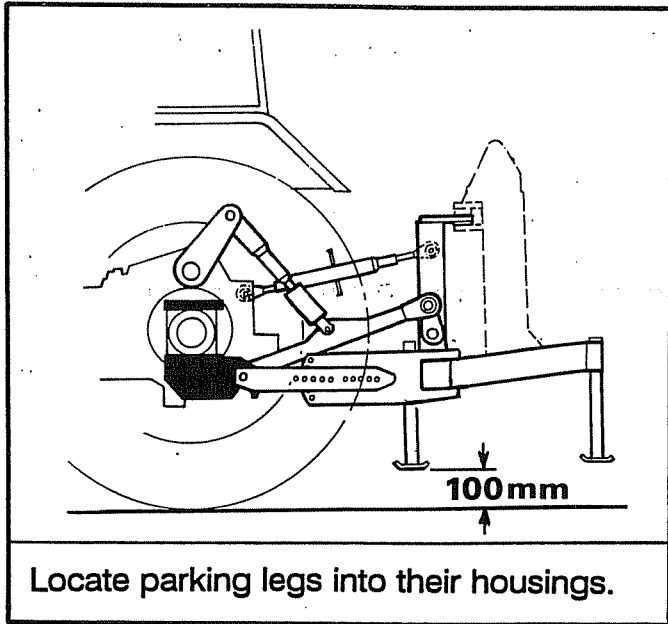

Place flail head on the ground directly to the rear at approximately half reach.

Disengage P.T.O.

Extract latch security pins.

Take machine's weight on draft link sufficiently to allow the top link to be disconnected.

Open catches and lower the machine.

Disconnect draft links and remove the P.T.O. shaft.

Remove control units from the cab and stow clear of the ground.

Drive tractor away.

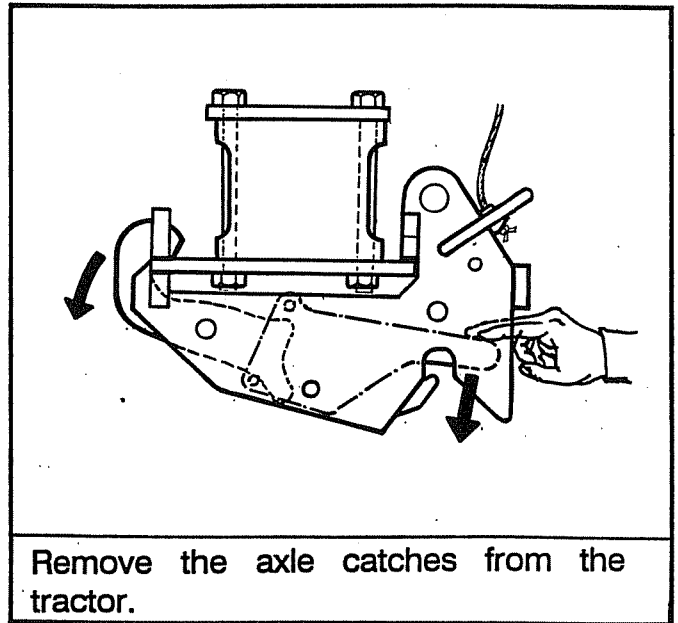

Replace the check chains/stabiliser bars.

The axle plates can remain permanently in position.

STORAGE

If machine is to be left standing for an extended period of time, lightly coat the exposed portions of the ram rods with grease. Subsequently this grease should be wiped off before the rams are next moved.

If the machine has to be stored outside tie a piece of tarpaulin or canvas over the control assembly **do not use a plastic bag** which could lead to corrosion..

OPERATION

MATERIAL THICKNESS CUTTING LIMITATIONS

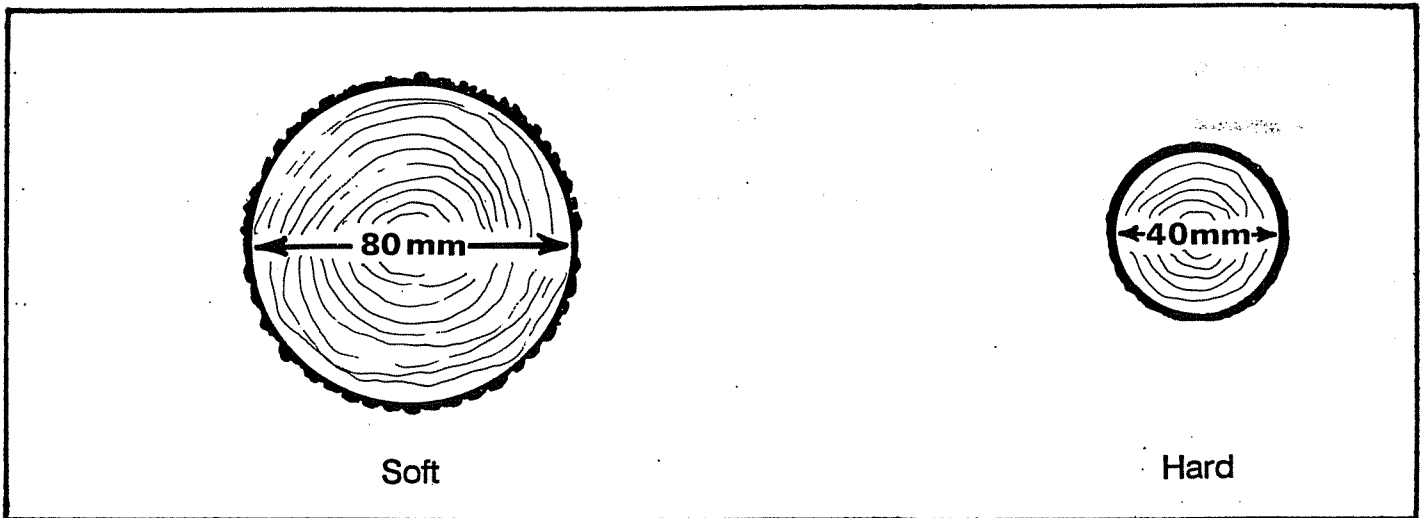

OPERATOR GUARD

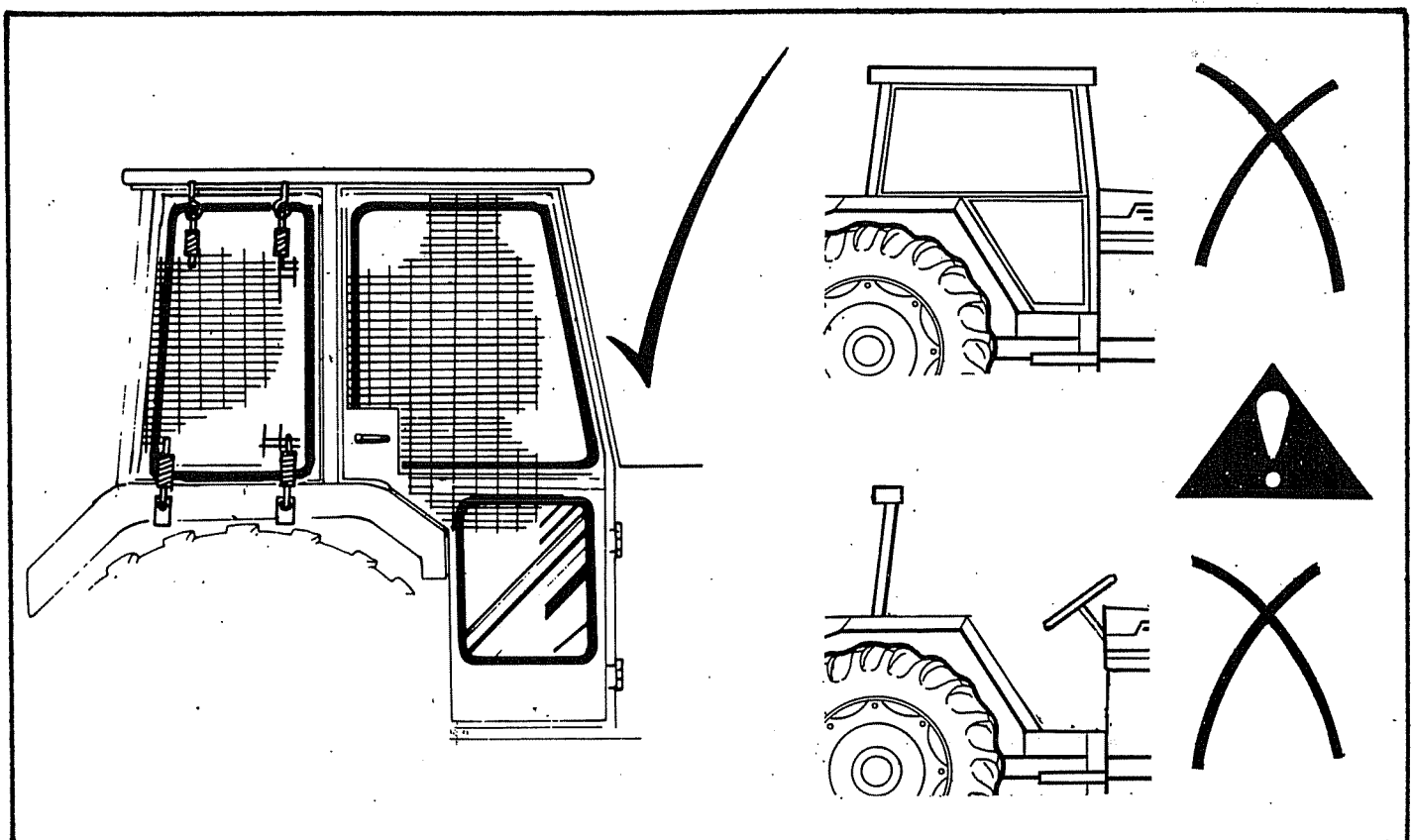

PREPARATION

Read the book first

Practise in an open space without rotor running until familiar with controls.

Caution: Take care when working with the head close in as it can hit the tractor

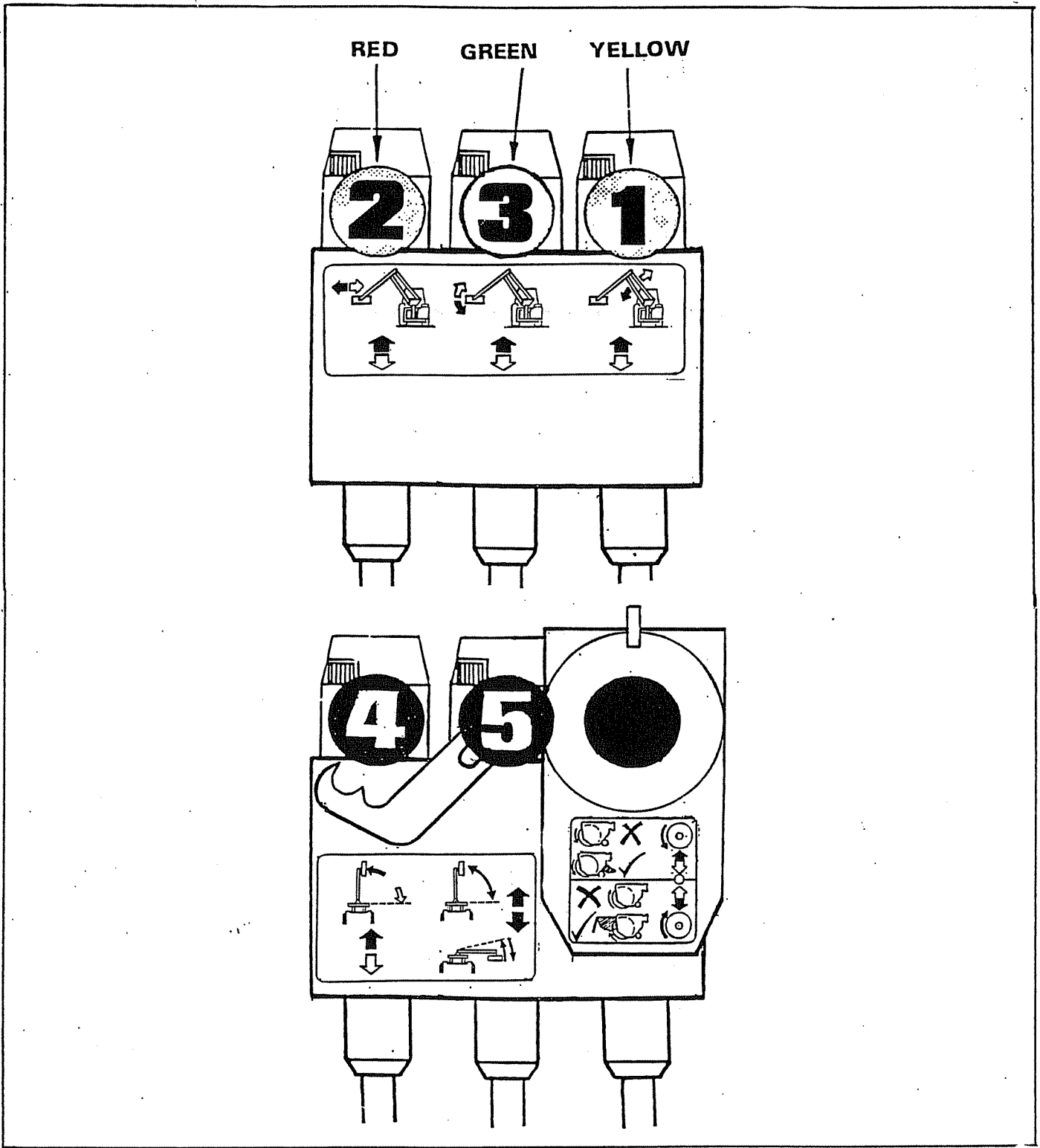

ARM CONTROLS

Lever functions

5

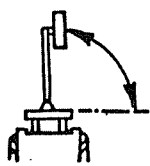

Slew - Allows slew working



Auto reset - Allows normal working

ARM CONTROLS

Lever functions

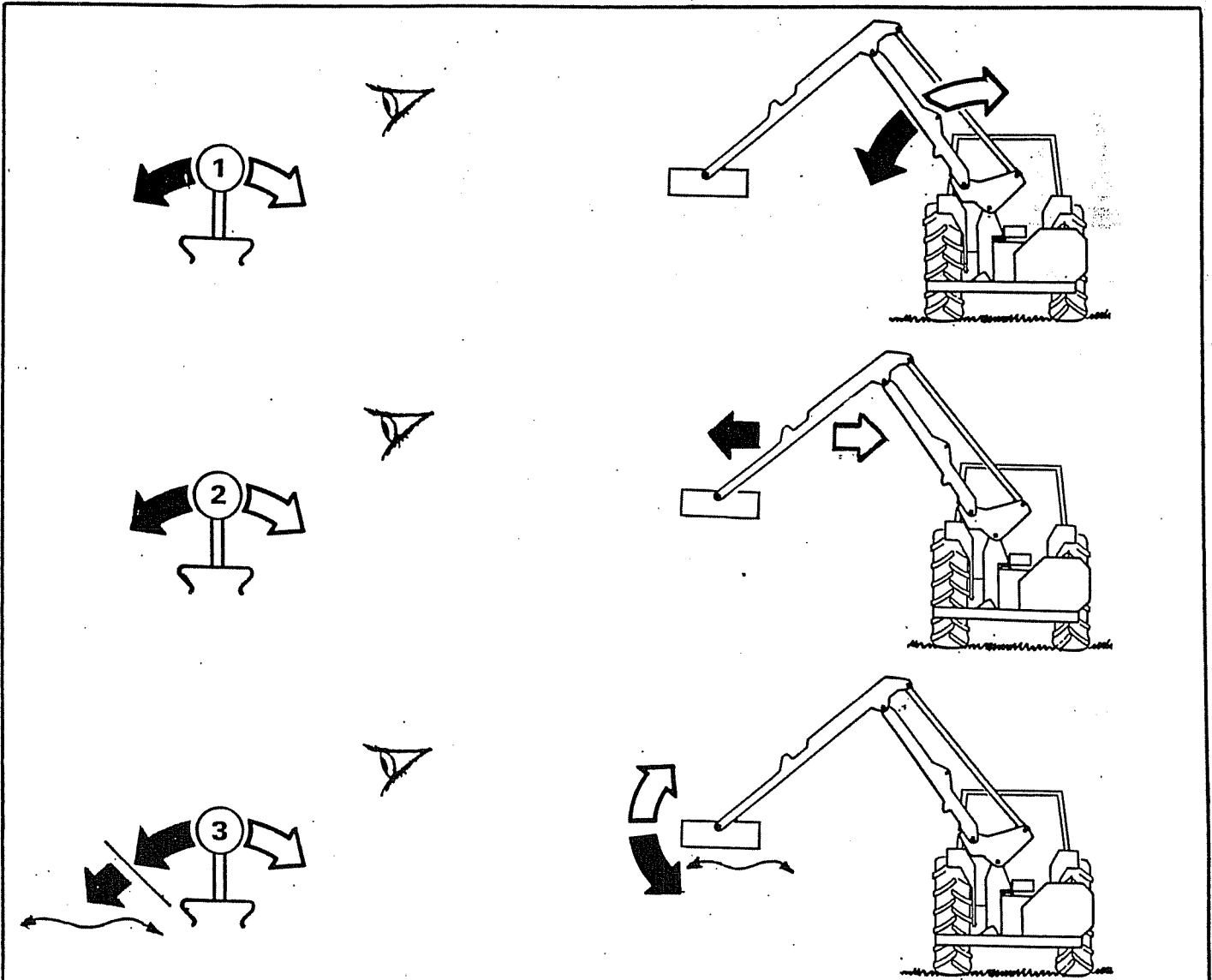

HEAD ANGLE FLOAT

An angle 'float' position can be selected which allows the fiail head to automatically angle itself to follow the contours of the ground .To obtain this position the control lever must be pushed away from the operator beyond its normal range until it locks into the float position.To return to normal operation the float position must be manually deselected.

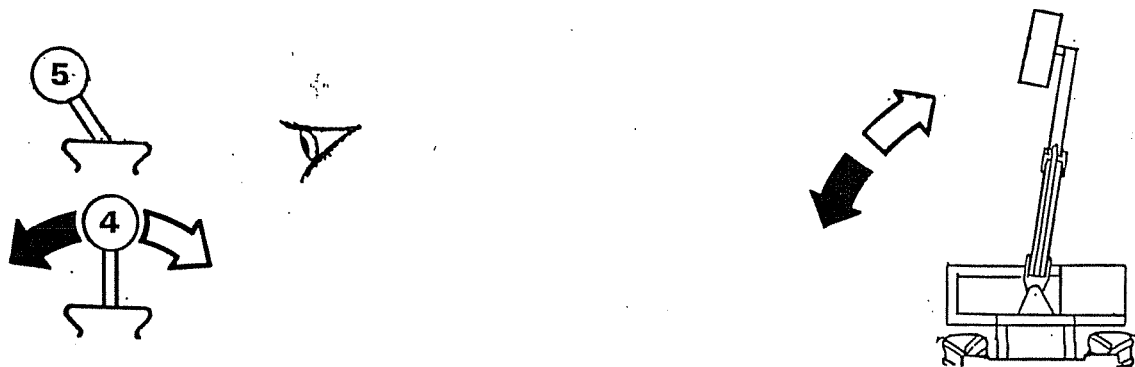

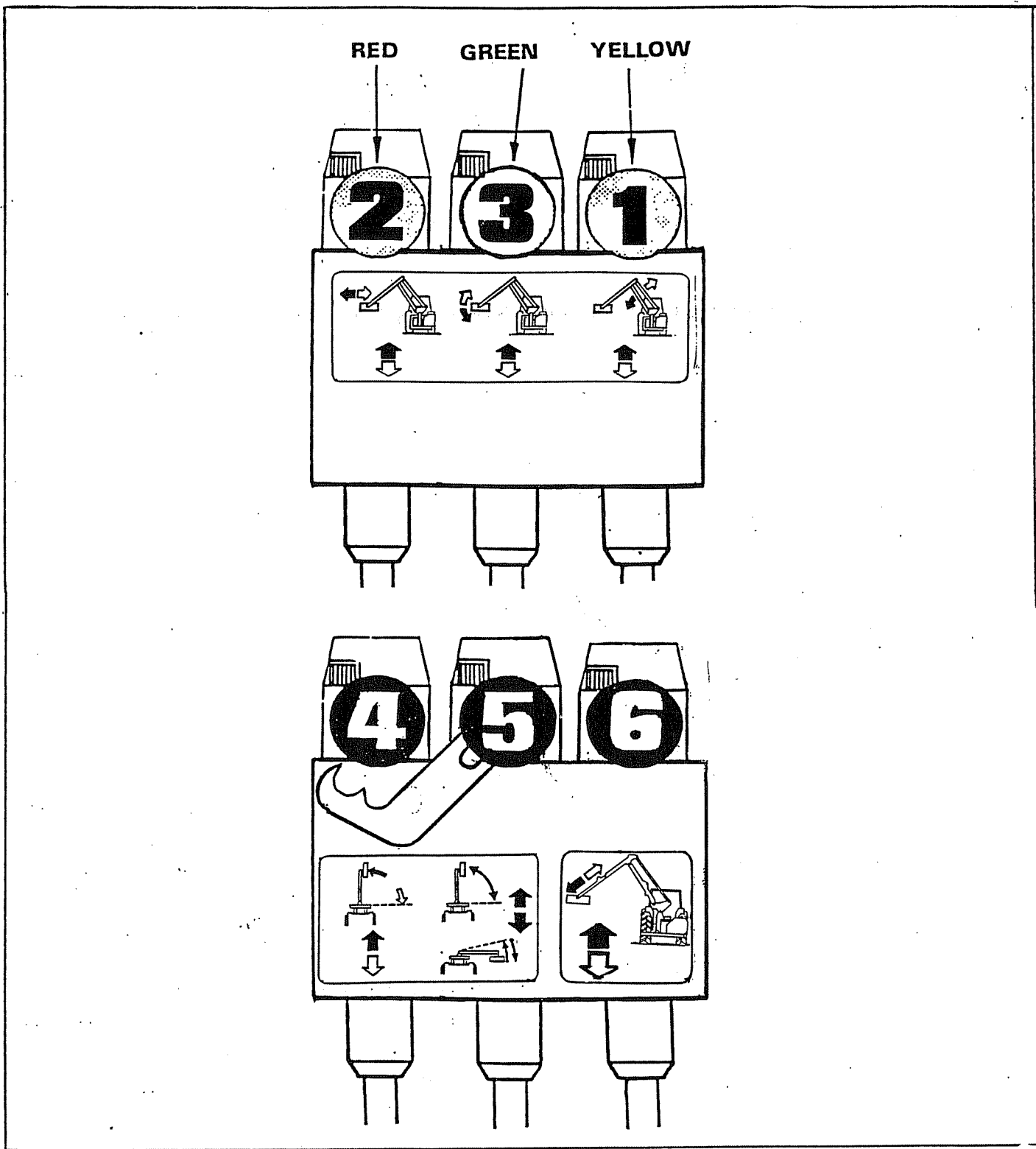

ARM CONTROLS

Lever functions

5

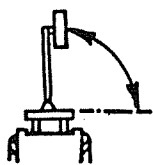

Slew - Allows slew working



Auto reset - Allows normal working

ARM CONTROLS

Lever functions

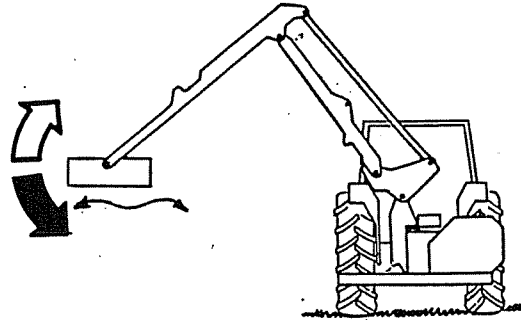
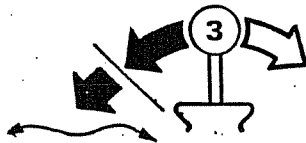
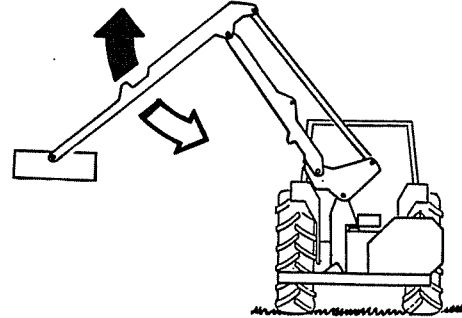
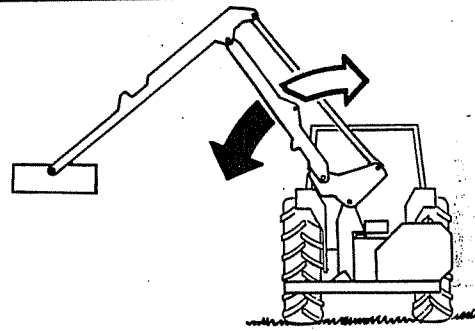
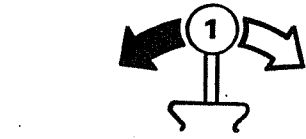

HEAD ANGLE FLOAT

An angle 'float' position can be selected which allows the fiail head to automatically angle itself to follow the contours of the ground .To obtain this position the control lever must be pushed away from the operator beyond its normal range until it locks into the float position.To return to normal operation the float position must be manually deselected.

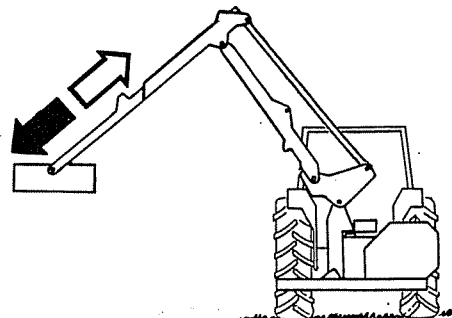
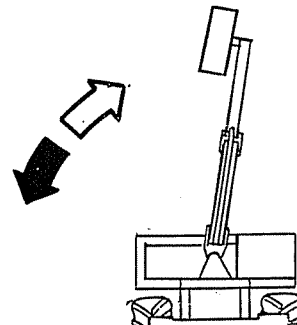
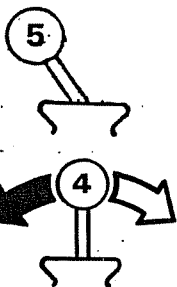

MACHINE CONTROL BOX - Electric controlled models only

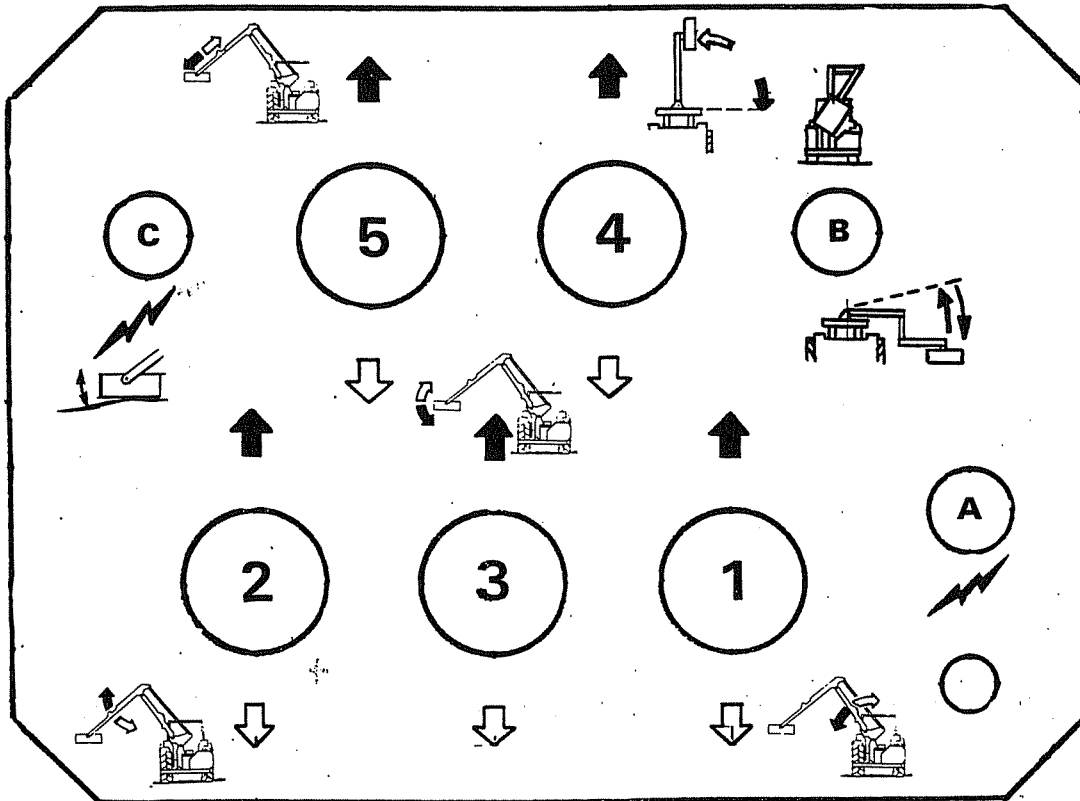
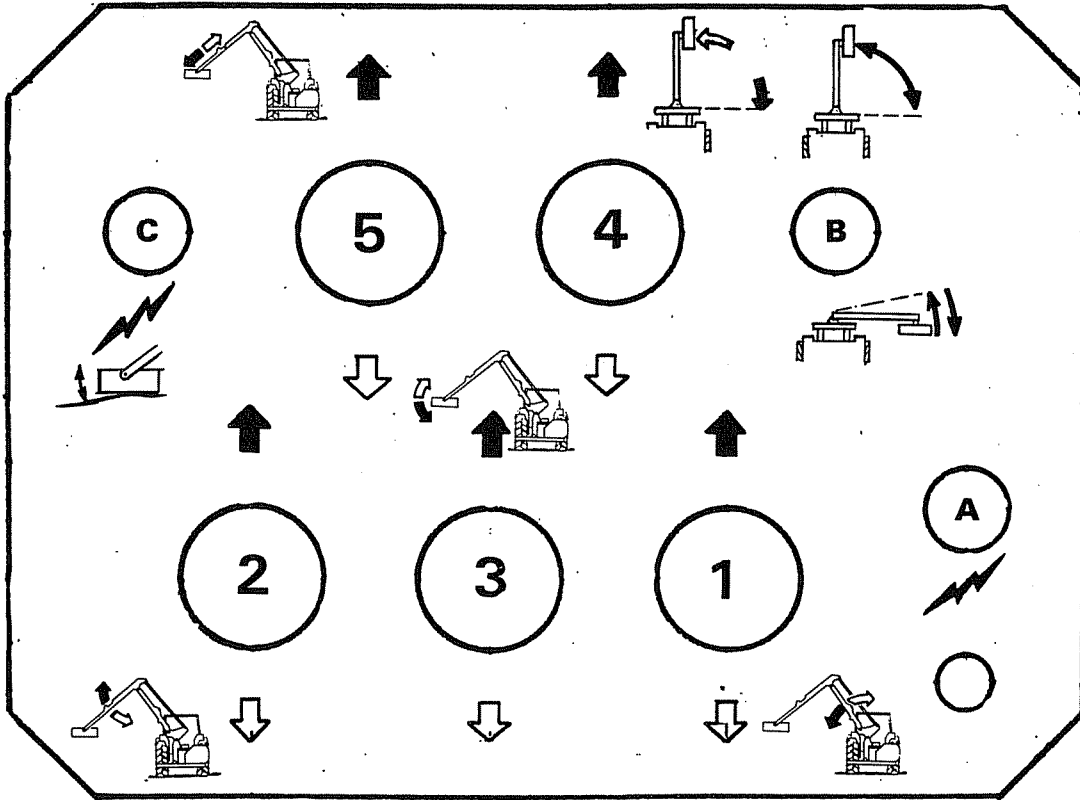

1 -- LIFT

2 -- REACH

3 -- ANGLE

4 -- SLEW

5 -- TELE (If fitted)

ARM CONTROLS

Lever functions

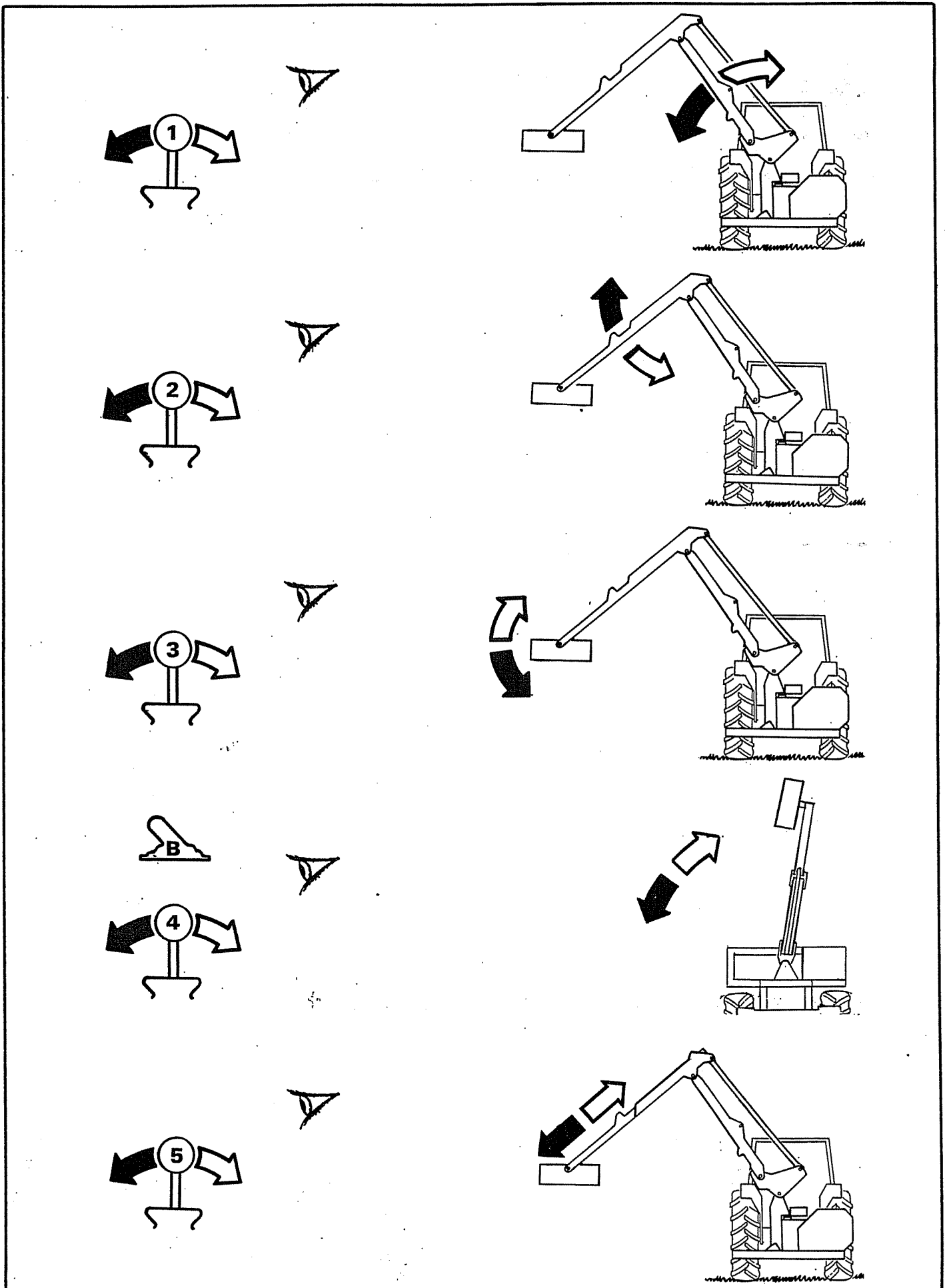

Switch functions - Electric controlled models only

A Power on/off

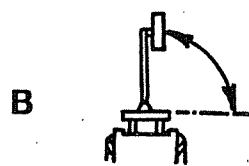

B Slew - Allows slew working



B Auto reset - Allows normal working



B Park - Allows slew and controlled breakback for transport.



B Work - Allows slew and normal working

Standard arm and telescopic

Mid cut only

C Head angle float on/off (if fitted)

ROTOR CONTROLS

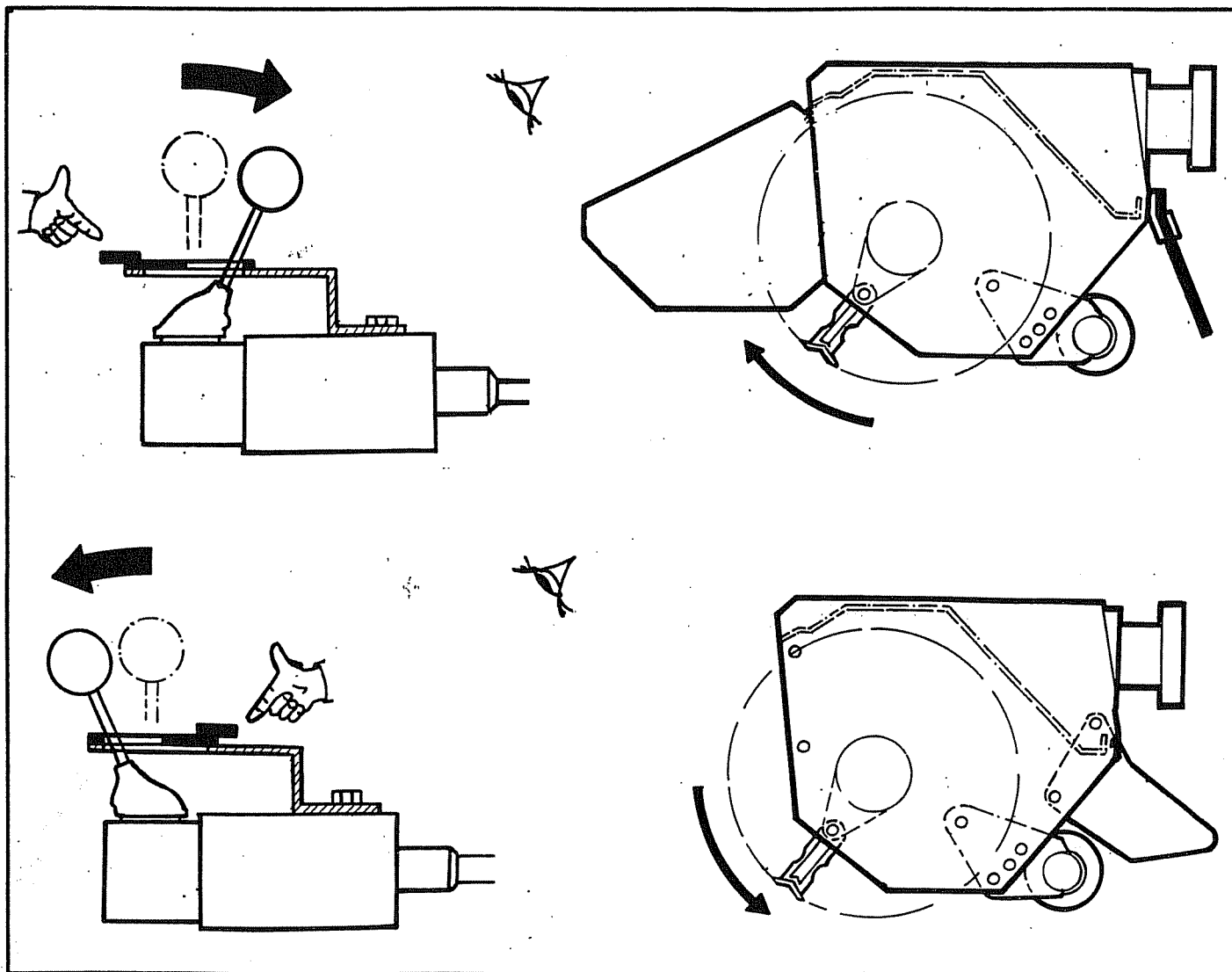

MOVING INTO THE TRANSPORT POSITION

Standard arm and telescopic

Position arms at approximately half reach

Select "**slew**" and "**slew in**" to position the arms to the rear of the tractor.

Fold the arms in and up taking care not to hit the cab. Fully screw in the lift ram tap.

Mid cut only

Position arms at approximately half reach with transport cradle in position on main arm.

Select "**slew in**" to position arms to the rear of the tractor

Operate "**reach in**" until limit switch stops movement.

Operate "**lift up**" until main arm is vertical.

Select "**park**"

Select "**lift up**" until breakaway ram is almost fully closed.

Select "**reach in**" and fine adjust "**lift**" to position the dipper in the transport cradle.

Select "**work**"

Operate "**lift up**" to achieve final transport position taking care to leave a minimum 12" (300 mm) between the arm and the cab.

Fully screw in the lift ram tap and select "**park**" before starting off.

TRANSPORT POSITION

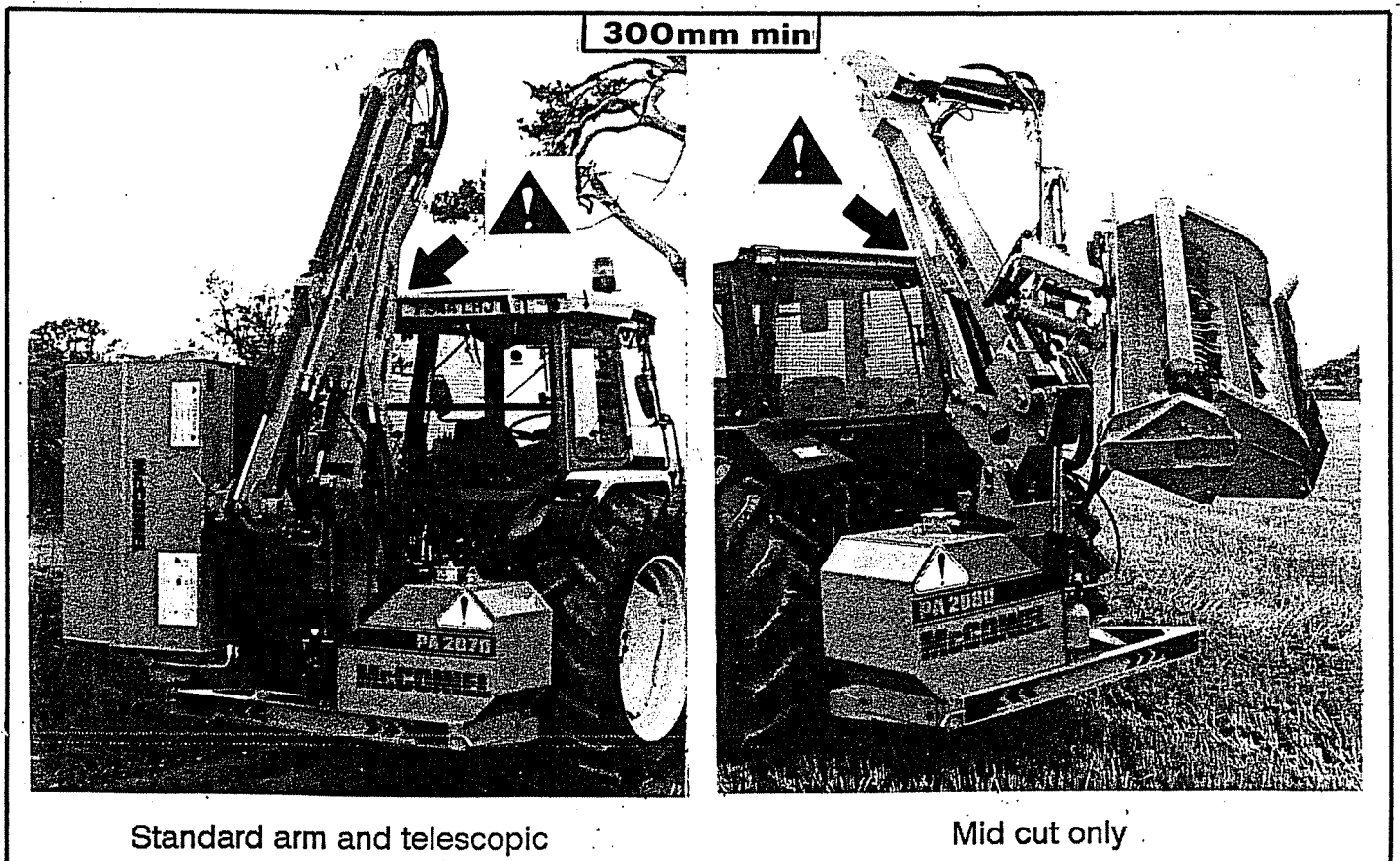

When in transport the PTO must be disengaged and the power to the control box switched off

WARNING

During transport the "Slew" mode for Std. arm & tele or the "Park" mode for the Mid cut must remain selected.

MOVING FROM TRANSPORT TO WORK POSITION

Standard arm and telescopic

Fully unscrew the lift ram tap.

Position arms to rear at approximately half reach.

"Slew out" and place head in the work position.

Select "Auto Reset" for general working conditions.

Mid cut only

Fully unscrew the lift ram tap.

Operate "Reach out" until limit switch stop is cleared.

Select "Work" on the control box

Operate "Lift up" until the breakaway ram is fully extended, i.e. when the main arm starts to move.

"Slew out" and place head in the work position.

ENGAGING DRIVE

Ensure rotor control lever is in the 'OFF' position and lever stop gate allows the required rotation.

Engage P.T.O. shaft

Allow the oil to circulate for a few minutes.

Place the flail head in a safe position.

Increase engine speed to high idle and move rotor control lever to 'ON'. After initial surging the rotor will run at an even speed.

ROTOR OPERATING SPEED

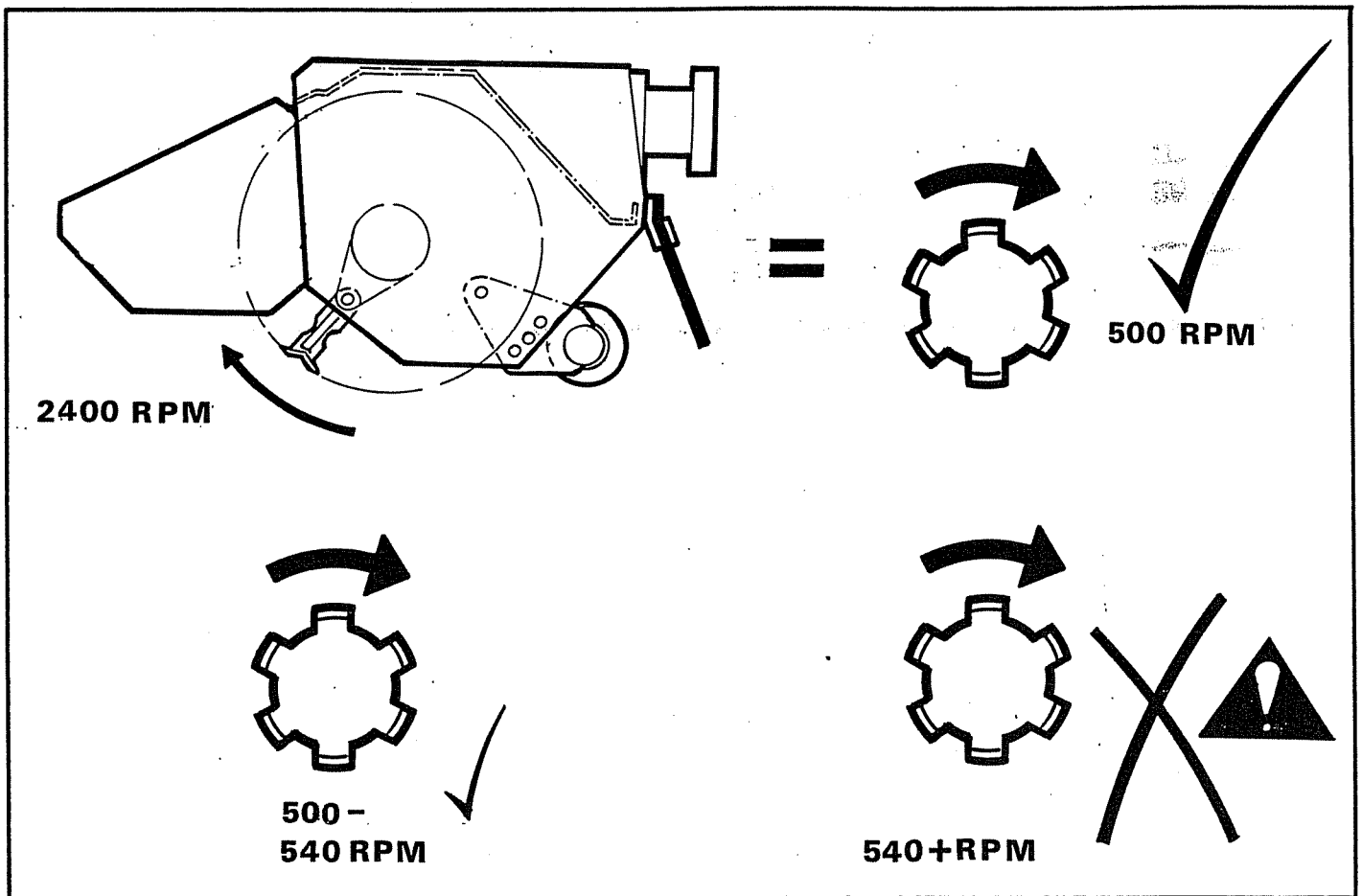

TRACTOR FORWARD SPEED

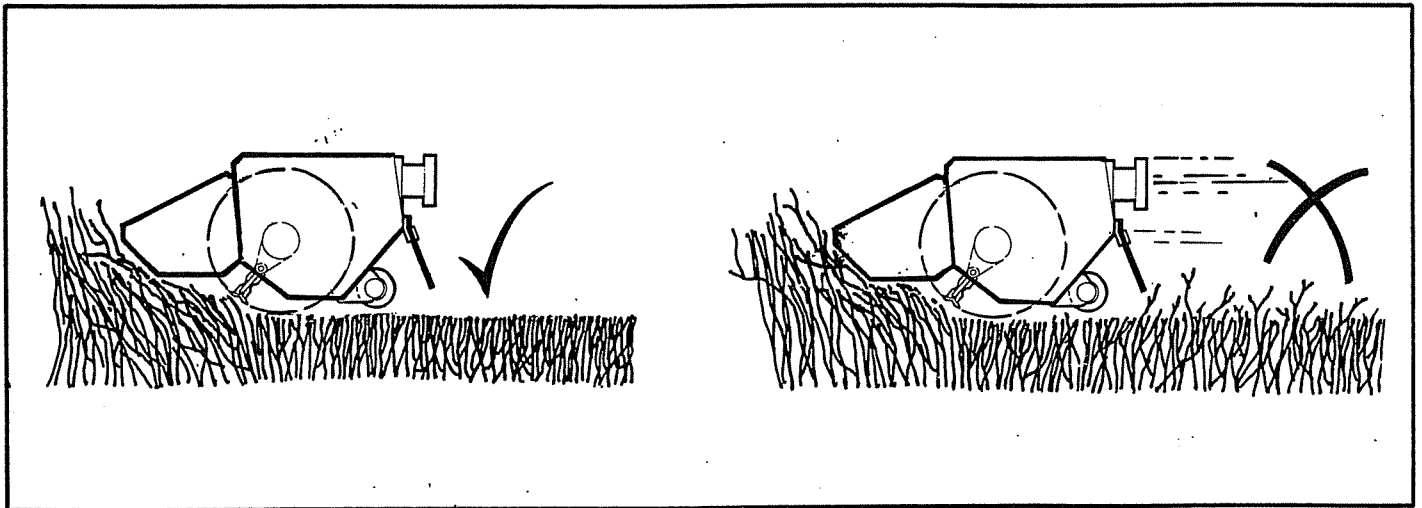

HIGHWAY WORKING

Local highway working regulations must be observed at all times.

WARNING

It is the operators responsibility to observe these regulations and to keep bystanders at a safe distance.

GENERAL WORKING PRACTISES

It is the operators responsibility to develop safe working procedures.

Always:-

Be aware of hazards in the vicinity

Make sure all guards are in position and in good condition.

Disengage P.T.O. before stopping the engine.

Wait until the flail has stopped running before leaving the tractor seat.

Disengage the P.T.O. and stop the tractor engine before making any adjustments.

Check frequently that all nuts and bolts are tight.

Keep bystanders at a safe distance.

BREAKAWAY

Standard arm and telescopic

With "Auto Reset" selected

Breakaway to the rear and up occurs when an obstacle is encountered. On clearing the obstacle the head automatically returns to the work position.

With "Slew" selected

When an obstacle is encountered the head breaks back horizontally until the obstruction is cleared. Re-setting the head is carried out manually by operating the slew lever.

Mid cut only

"Work" is always selected.

When an obstacle is encountered the head will break up and back. On clearing the obstacle the head is automatically reset for work.

When working at full reach the complete arms and column may break back to allow the obstacle to be cleared. When this occurs it has to be reset by selecting "Slew out"

WORKING ON ADVERSE SLOPES

When working high with the reach fully in it is possible for the main arm balance to go over centre and take the weight off the lift ram. A restrictor in the gland connection of the lift ram prevents sudden unpredictable movements should this occur.

WARNING

**Do not remove this restrictor
from the lift ram gland connection**

To regain the lower position extend the reach ram to return the centre of balance onto the lift ram which will then retract when 'Lift down' is selected.

POWERED SLEW

97 degrees of powered slew allows awkward areas to be cut more easily.

Standard arm and telescopic

"Slew" must be selected on the switch box.

Mid cut only

"Work" must be selected

AUTO HEAD CONTROL

An automatic function which maintains the flail head angle at the chosen setting during normal 'Lift' and 'Reach' adjustments.

Note:- The performance of the function deteriorates when working within half a metre of full reach.

Should "Head angle float" be selected the auto head control feature ceases to function. On de-selection it becomes automatically re-instated.

TELESCOPIC DIPPER

The telescopic dipper gives 1.05 metres of extra reach.

Normally the tele is pre-set and then the machine operated using the normal controls. The 'Tele' function could be used in place of 'Reach' but a slower response to the controls must be expected.

'Tele' alters the parallel motion geometry. This works best at ground level when 'tele' is fully out and at 4 -5 feet (1.2 - 1.5 metre) high when fully in.

WIRE TRAP

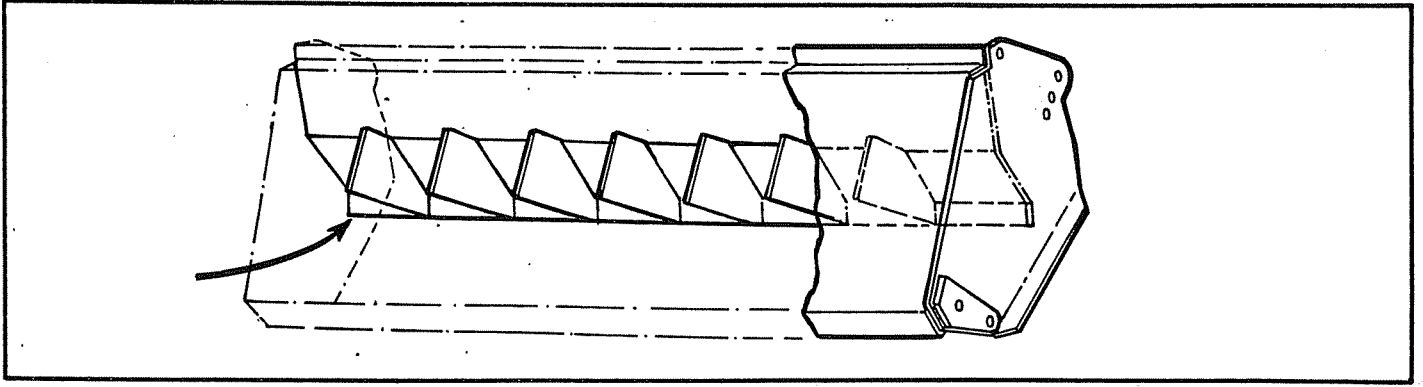

Both flail hoods are equipped with a wire cutting edge welded into the underside. This plate should not be interfered with in any way.

Any wire caught in the rotor must be immediately removed.

REMOVING WIRE

Select rotor 'OFF' and wait until it has **stopped rotating**.

STOP the tractor and only then remove wire.

Do not reverse the rotor in an attempt to unwind any wire.

OVERHEAD OBSTRUCTIONS

Always be aware the machine is approximately 4 metres high when folded and take extra care when manoeuvring in areas with overhead obstacles especially power cables.

HIGH VOLTAGE CABLES

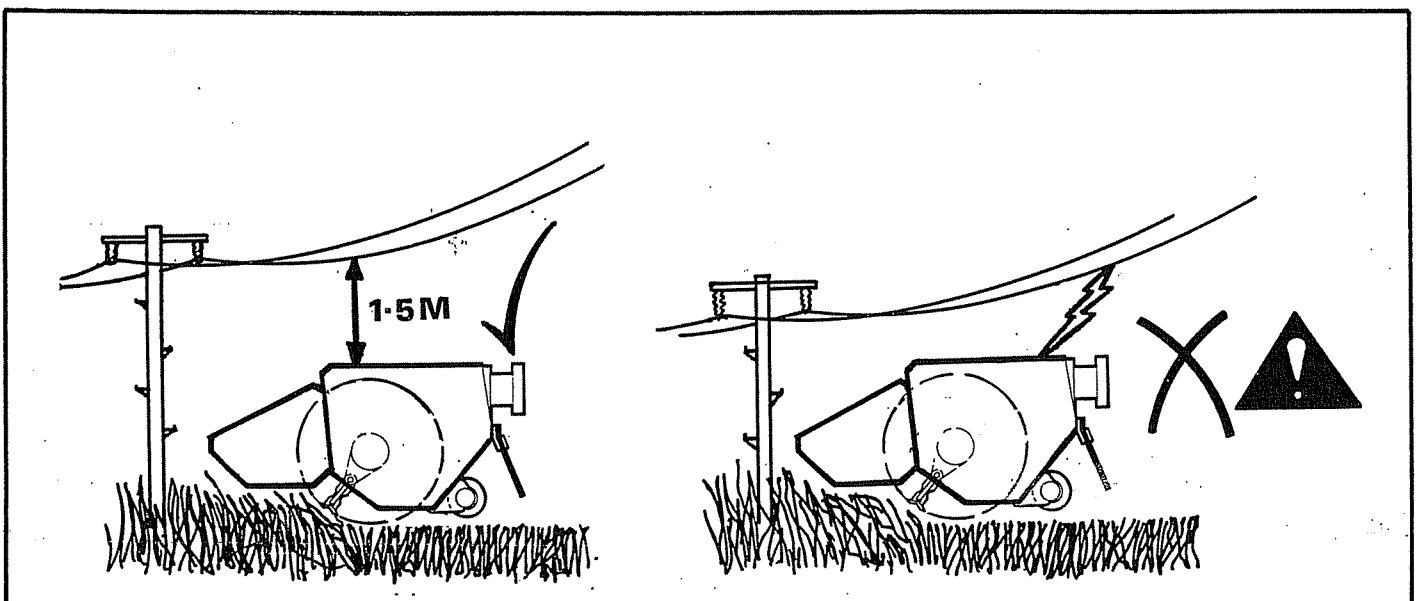

If in doubt consult your local electricity company regarding a safe procedure for work.

HEDGE CUTTING PROCEDURE

Preliminary Precautions

Inspect the work area, remove hazardous materials and note any immovable obstructions.

Upward cutting

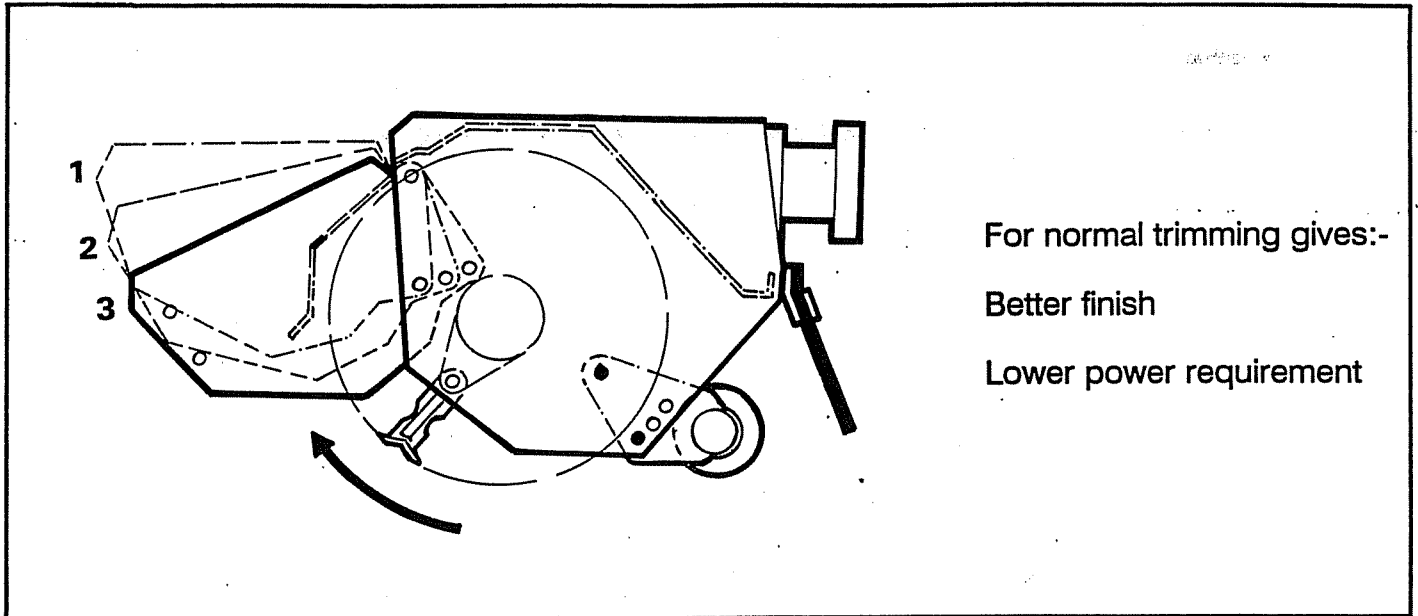

Front hood and rear flap must always be in position.

Downward cutting

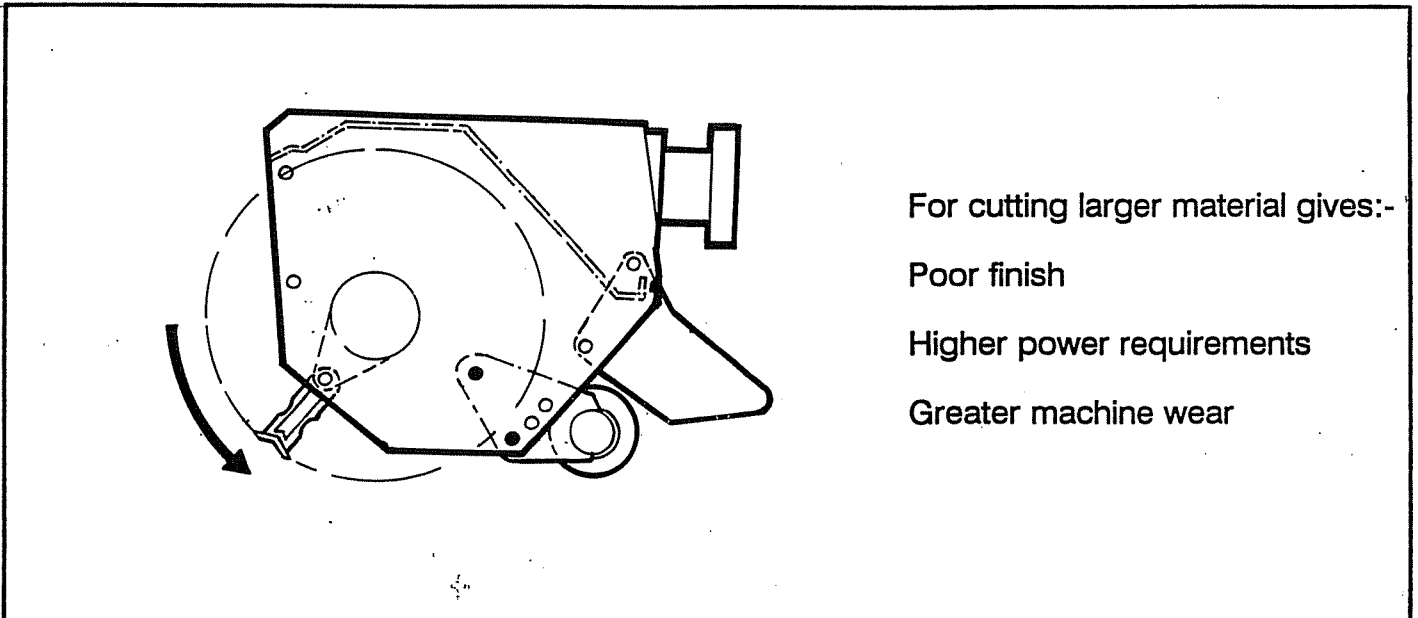

Rear hood Part No. 71 90 285 must be fitted

Reversing rotation

Select Rotor 'OFF'

Wait until rotor has **stopped** rotating

Swing lever stop gate through 180 degrees to allow opposite rotation to be selected.

Caution. Do not remove the lever stop gate.

Cutting sequence

1

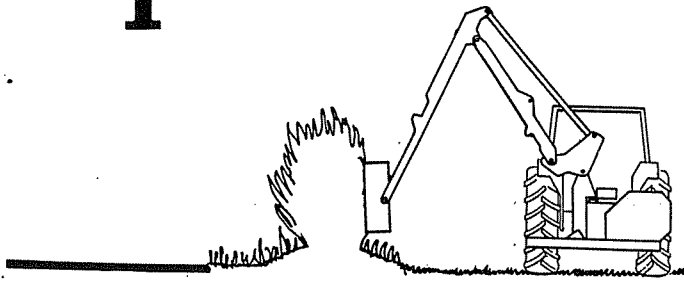

2

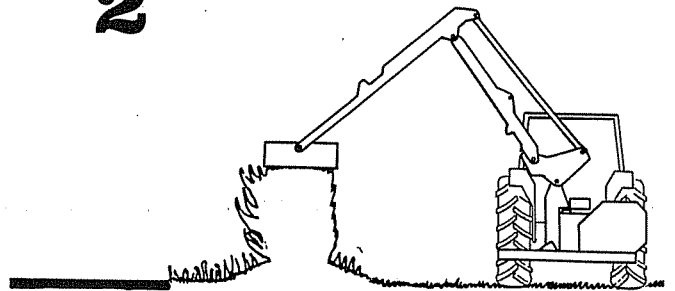

3

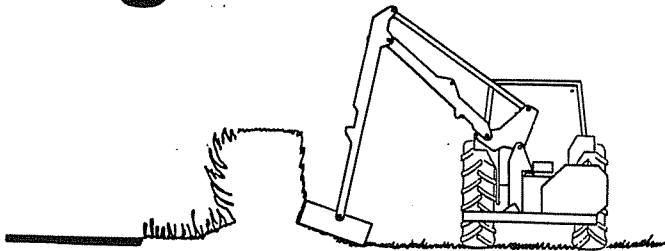

4

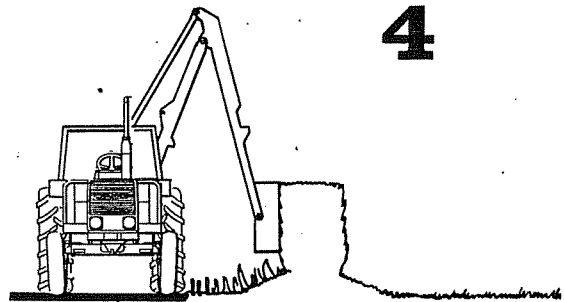

5

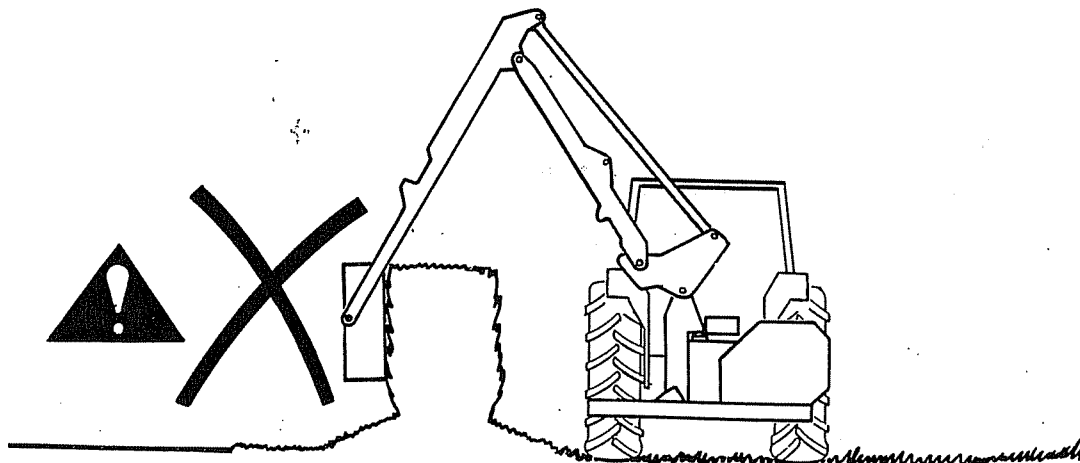
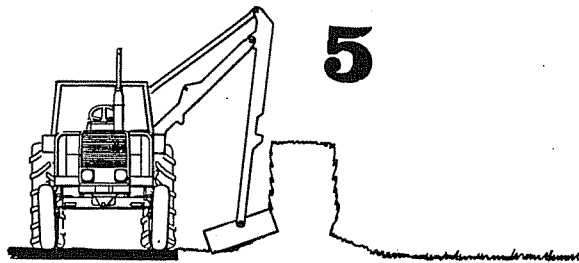

GRASS CUTTING

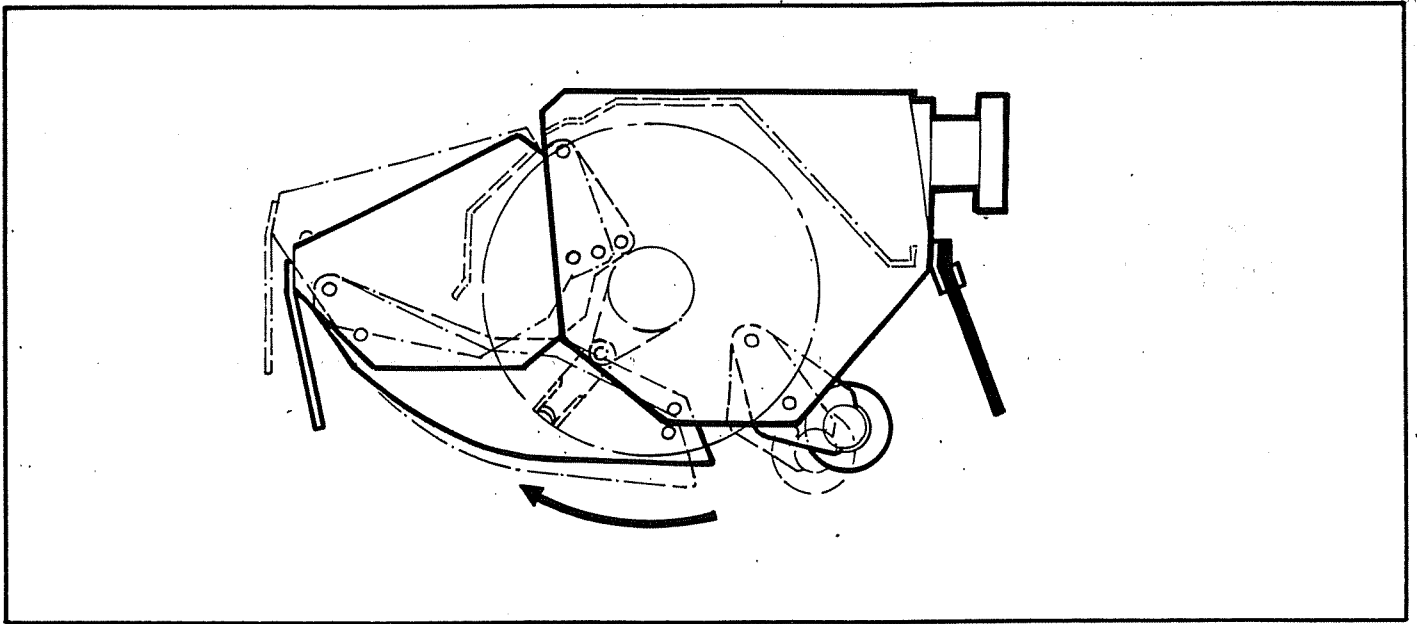

Flails must cut upwards

Front hood cw flaps, skids and rear flap must be fitted.

The mounting holes allow two positions for the front hood and two positions for the skids. Any combination of these positions may be used.

The roller can be set in either position 2 - 4

ROLLER POSITION

Bushed roller

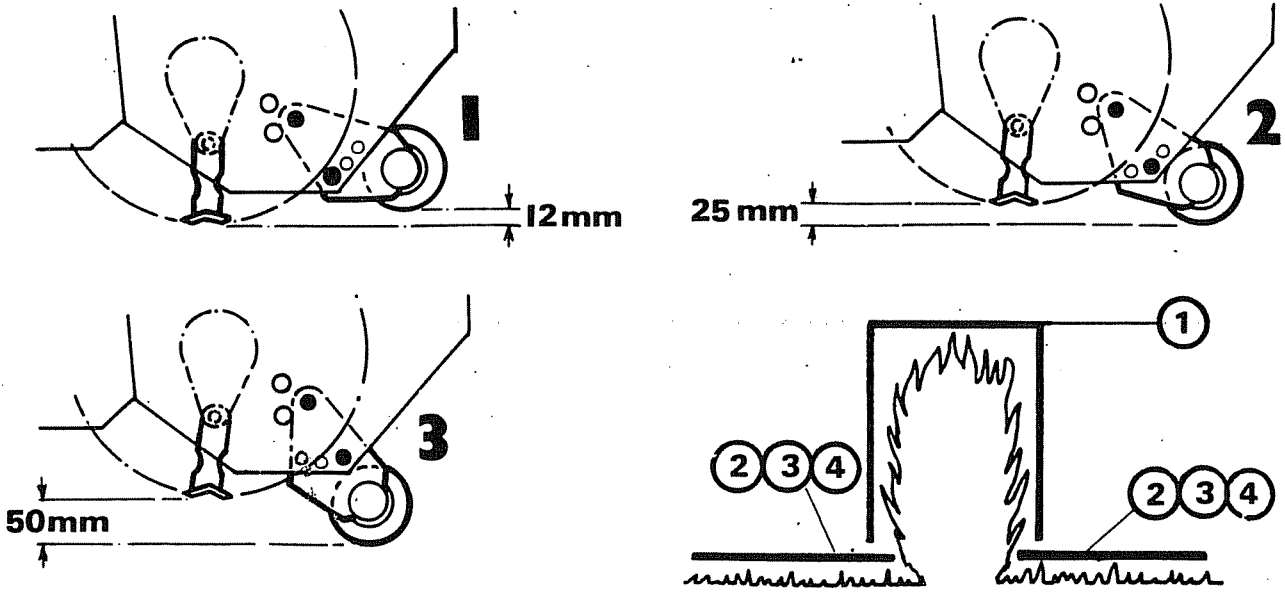

Ball bearing roller

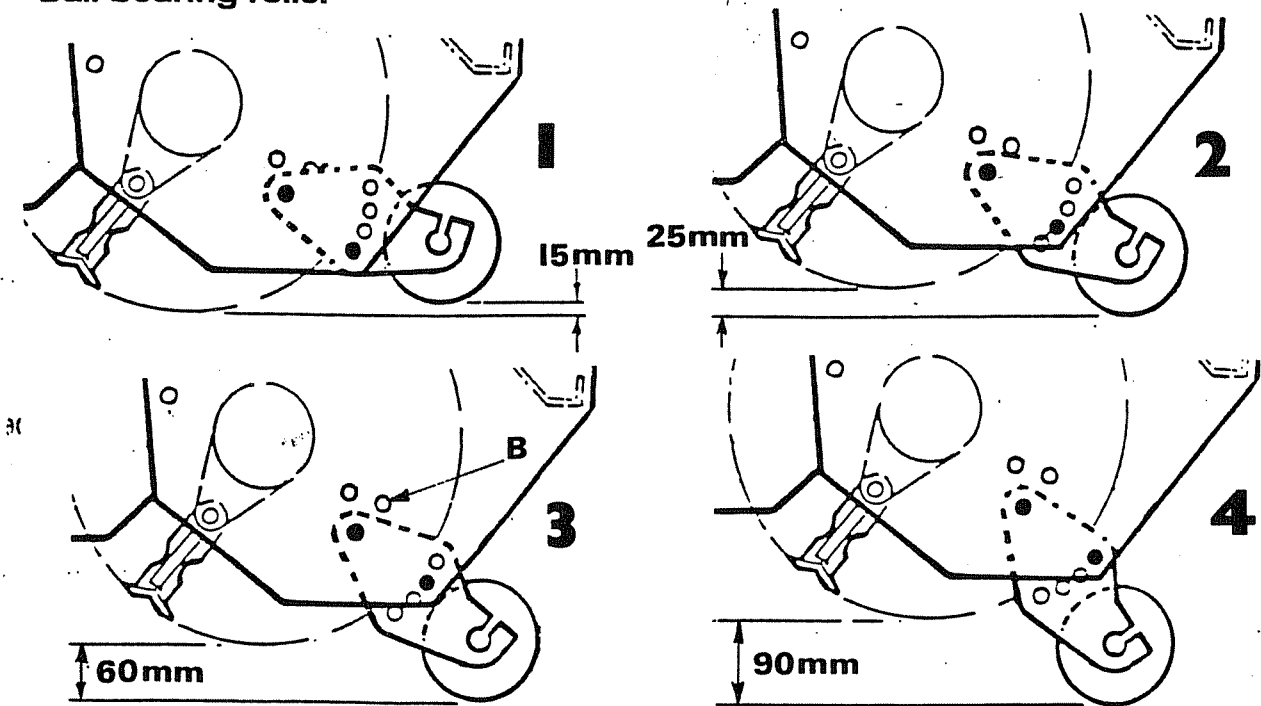

Warning

The ball bearing roller must never be mounted in position B.

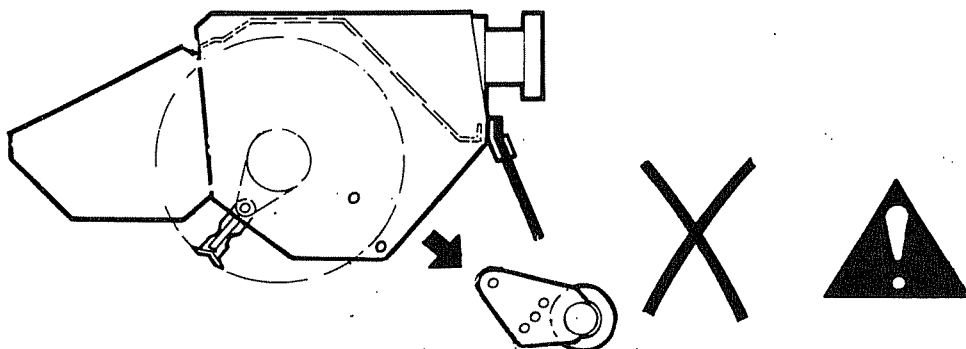

LIFT FLOAT KIT (optional extra)

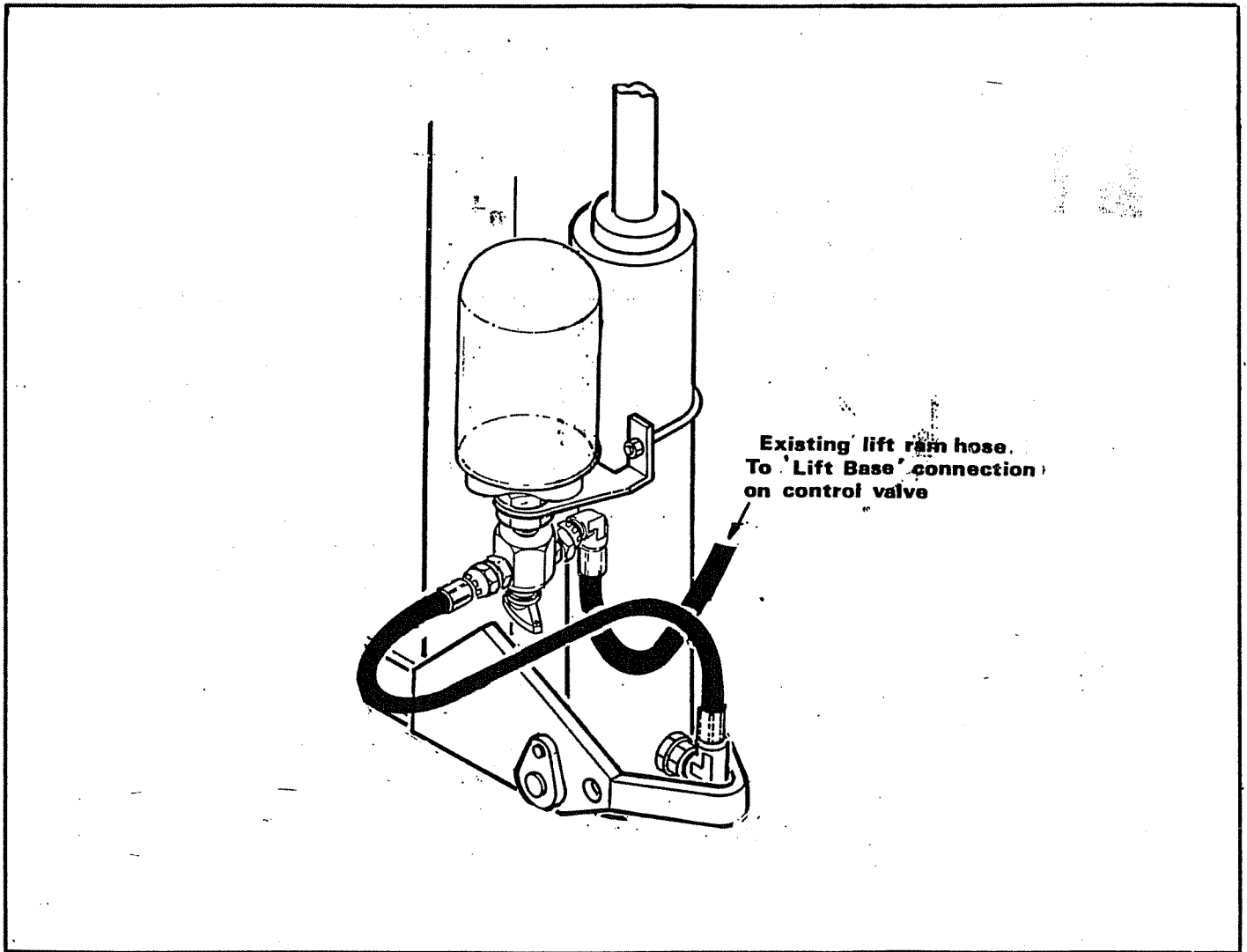

The hydraulic float kit, if fitted, should be mounted as shown in the vertical position clamped to the lift ram barrel.

In work, with the tap open the flail head automatically follows the ground contours.

The lift control should be operated to take a proportion of the flail head weight off the flail roller. This is important, too little weight on the roller will leave uncut areas of grass while with too much weight on the roller the ground will be scalped in places and increased flail wear, loss, or damage to flails could occur.

To revert to hedge cutting or to use the flail without it running along the ground the stop tap should be closed to isolate the accumulator.

FLOATING HEAD ANGLE FACILITY **Optional extra**
 - Electric controlled models only

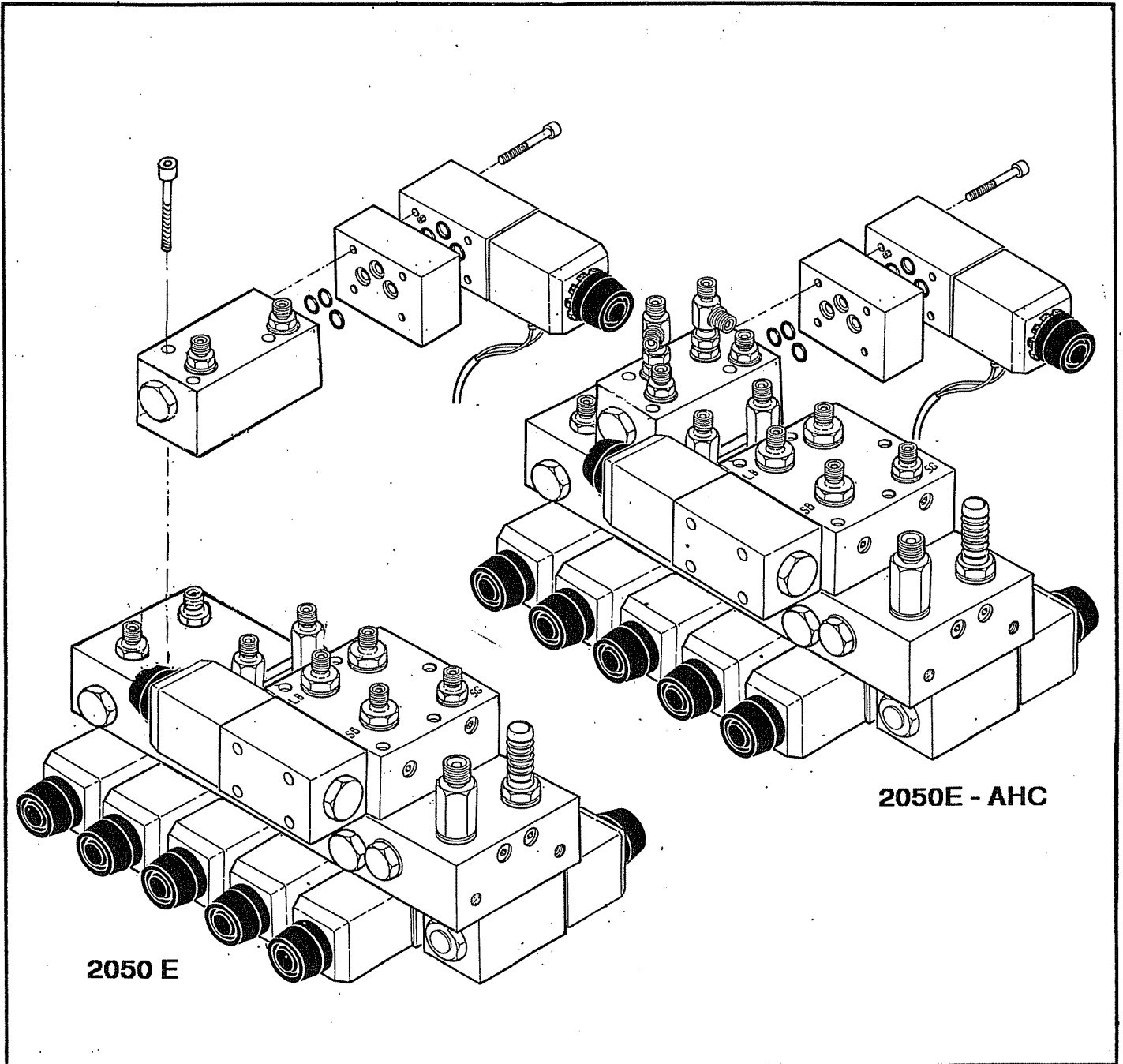

FLOATING HEAD ANGLE FACILITY **Optional extra for electric controlled machines.**

This facility will allow the flail head to angle itself automatically to suit the contours of the ground. It is activated by selecting **C**

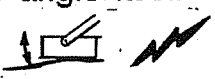

The kit is bolted in position as shown. The 'O' rings from either the the hose plate on 2050E and 2050E - Tele or the Compensator valve blanking plate on 2050E AHC and 2050E - Tele AHC must be extracted carefully and re-used .

The two core cable is connected from the solenoid to the common link harness and connection 9 on the main harness..

MAINTENANCE

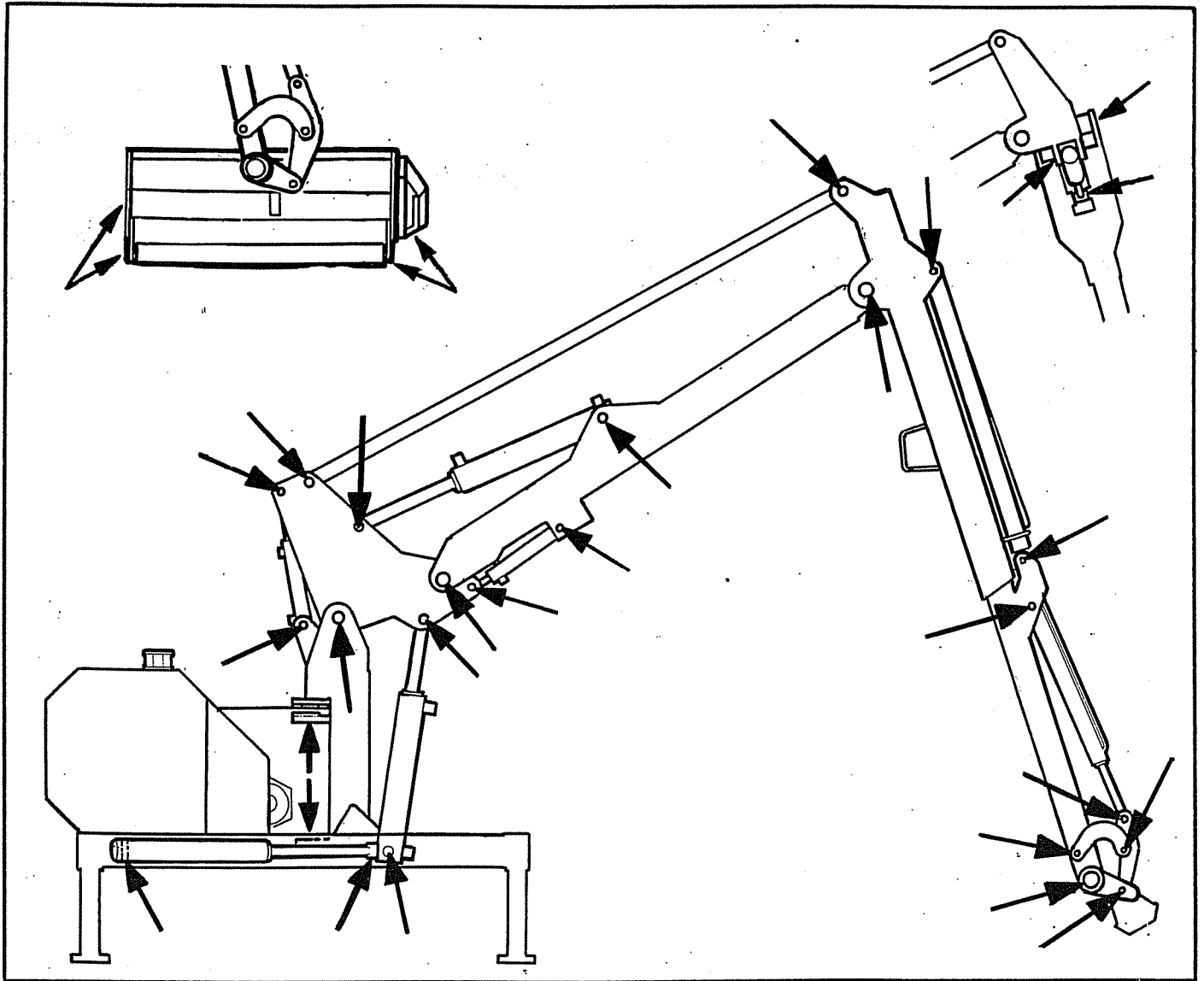

LUBRICATION

General

Grease daily all points shown.

In addition, on PA2050 tele the "tele" dipper wear pads must be greased weekly.

Power take-off shaft

The P.T.O. shaft and its guards should be regularly examined. The universal joints should be greased very sparingly i.e. one shot weekly.

Note: Overgreasing a universal joint will blow-out the cork or neoprene sealing rings that exclude the dirt from the needle bearings inside.

The two halves of the plastic guard should be checked daily to ensure that they can spin freely on the shaft. The nylon slip rings which support the guard on the drive shaft should be lightly greased at weekly intervals.

The telescopic drive shaft should be similarly separated and grease applied to the internal shaft at approximately 100 hour intervals.

HYDRAULIC SYSTEM

Oil supply

Check the oil level in the reservoir daily.

No fixed time period can be quoted for oil changes as operating conditions and maintenance standards vary so widely. Burnt and scorched oil odours and the oil darkening and thickening are all signs of oxidation and indicate the oil should be changed.

Moisture which results from condensation can become entrapped in the oil and cannot be removed by filtration so that water contamination is progressive.

Contamination can be reduced by:-

- 1) Cleaning off around the reservoir cap before removal, and keeping that area clean
- 11) Using clean containers when replenishing the system
- 111) Regular servicing of the filtration system

Filtration Maintenance

The machine is protected by a 125 micron suction strainer and a low pressure 10 micron full flow return line filter.

- 1) Suction strainer

The strainer is permanently fixed within the reservoir.

Should symptoms of pump cavitation or spongy intermittent operation occur the tank must be drained and flushed out with a suitable cleaning agent eg. clean diesel oil

- i11) Return Line Filter

The element should be changed after the first 50 hours and thereafter at 500 hour intervals. It is important to note hours worked as if the filter becomes blocked an internal by-pass within the canister will operate and no symptoms of filter malfunction will occur to jog your memory.

FLAILHEAD

Frequently inspect the rotor assembly for damaged or missing flails. Bolts and nuts securing the flails to the rotor should be regularly checked and kept tight. The correct torque setting for these locknuts is 135 Nm (100 lbf/ft.). Use only the correct flail bolt and locking nut. Check the flail pivot bushes for possible damage or wear. They do not require oil.

Do not attempt to run the rotor with flails missing. Im-balance will cause severe vibration and can rapidly damage the rotor shaft bearings. As an emergency measure if a flail is broken off or lost, remove another on the opposite side of the rotor to retain balance. Always replace flails in opposite pairs and never match up a new flail with a re-sharpened one which will of course be lighter.

Blunt flails absorb a lot of power and leave an untidy finish to the work. They should be sharpened on a grindstone or with a portable grinder periodically.

Wear protective gear when sharpening flails.

Ensure that the bearing housings and hydraulic mounting nuts and bolts are kept tight. They should be checked during servicing.

CABLES

The cables operate on a push/pull system with the spool centering springs always returning the spool to the neutral position when the handle is released.

Care should be taken during installation and operation to ensure that the cables are not trapped or kinked. Any abrasion or damage to the outer casing should be sealed with plastic insulation tape to avoid moisture penetrating.

No routine adjustment of the cables are necessary as they do not stretch. The threaded collar is correctly adjusted when the lever is in a vertical position in its housing allowing an equal amount of travel in either direction

CAUTION On no account should any attempt be made to lubricate the cables which are assembled with a special lubricant during manufacture.

NOTE Take care to ascertain the correct cable connections on both the control unit and the valve in the event of cable replacement.

P.T.O. GEARBOX

The gearbox is rigidly bolted on to the main frame and has a filler plug. Oil level is correct when level with the filler plug aperture. The gearbox oil should be changed every two years or at 1000 hour intervals: whichever occurs first. The capacity of the gearbox is .25 litres (1/2 pints) S.A.E. 30/50 Tractor universal oil.

HYDRAULIC HOSES

The condition of all hoses should be carefully checked during routine service of the machine. Hoses that have been chafed or damaged on their outer casing should be securely wrapped with waterproof adhesive tape to stop the metal braid from rusting. Hoses that have suffered damage to the metal braid should be changed at the earliest opportunity.

Hose replacement

- a. Replace one hose at a time to avoid the risk of wrong connections.
- b. When the hose is screwed to an additional fitting or union, use a second spanner on the union to avoid breaking both seals.
- c. Do not use jointing compound on the threads.
- d. Avoid twisting the hose. Adjust the hose line to ensure freedom from rubbing or trapping before tightening hose end connections.

Before changing hoses study the installation these are carefully calculated to prevent hose damage during operation. Always replace hoses in exactly the same manner. This is especially important for the flail hoses where they must be crossed, upper to lower, at the dipper and head pivots. The 90 degree elbows at the head bracket must point directly across the pivot and the hoses must have no slack at this point.

Two hose clips are provided at either end of the large bore suction and return hoses. These should be positioned so that their worm drive barrels are opposed at 180 degrees to reduce the possibility of air entering the system. A stop tap is provided to enable the suction hose to be changed without draining the tank.

Hose warranty

Warranty is limited to replacement of hoses which have failed due to faulty materials or manufacture. Warranty will not be considered on hoses that have suffered damage by abrasion, cuts or being pinched or trapped while in work. Neither will a claim be considered where a hose end has been damaged by a blow or where the threads or unions have been damaged by overtightening.

HOSE CONNECTIONS

MAIN VALVE 2050 Cable controls Std arm

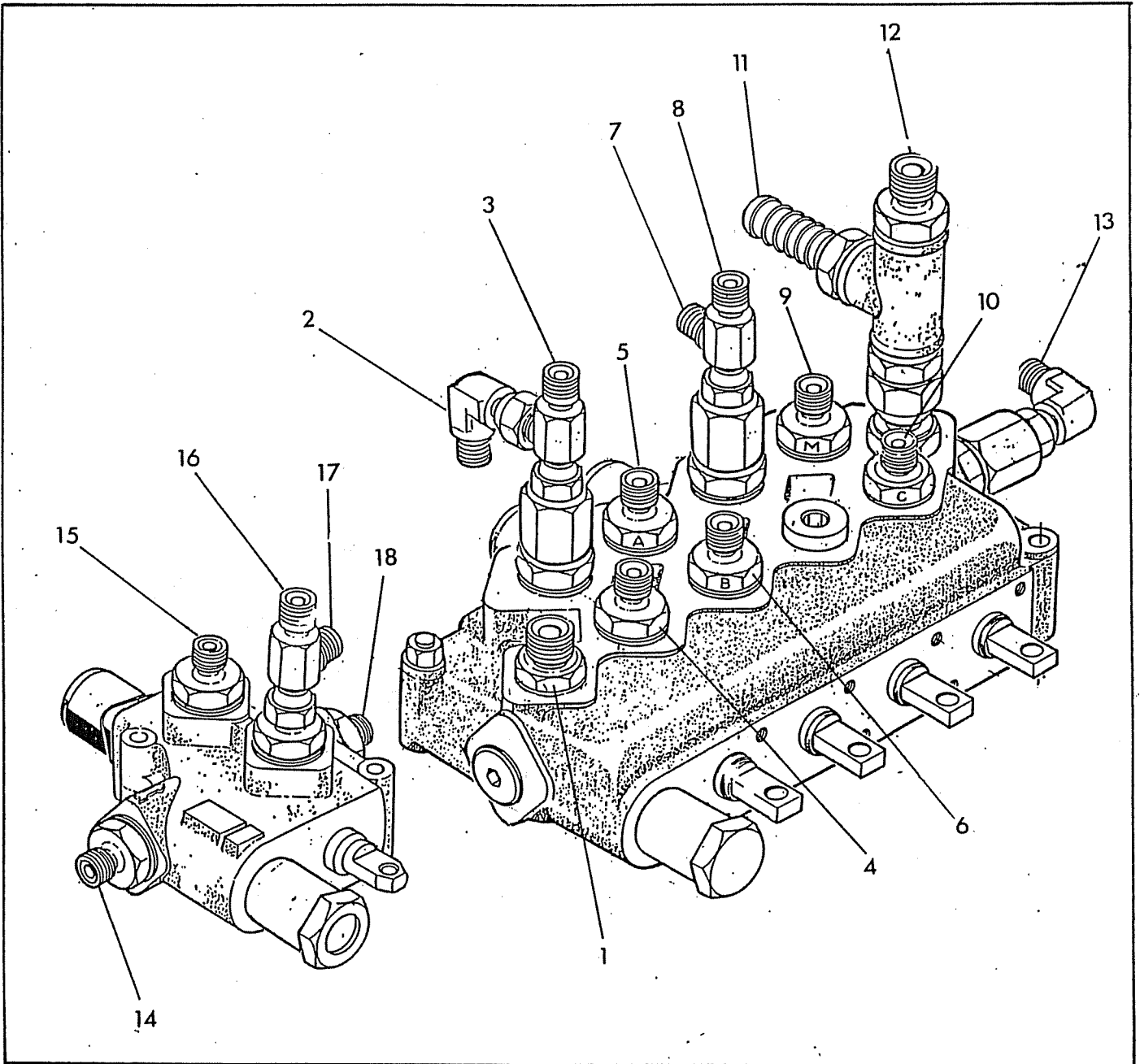

1. Supply from pump

2. Slew base

3. Connection 14

4. Connection 16

5. Reach gland

6. Reach base

7. Lift base

8. Connection 15

9. Angle gland

10. Angle base

11. Return to Rotor valve

12. Connection 18

13. Lift gland

14. Connection 3

15. Connection 8

16. Connection 4

17. Slew gland

18. Connection 12

HOSE CONNECTIONS

MAIN VALVE 2050 Cable controls Tele

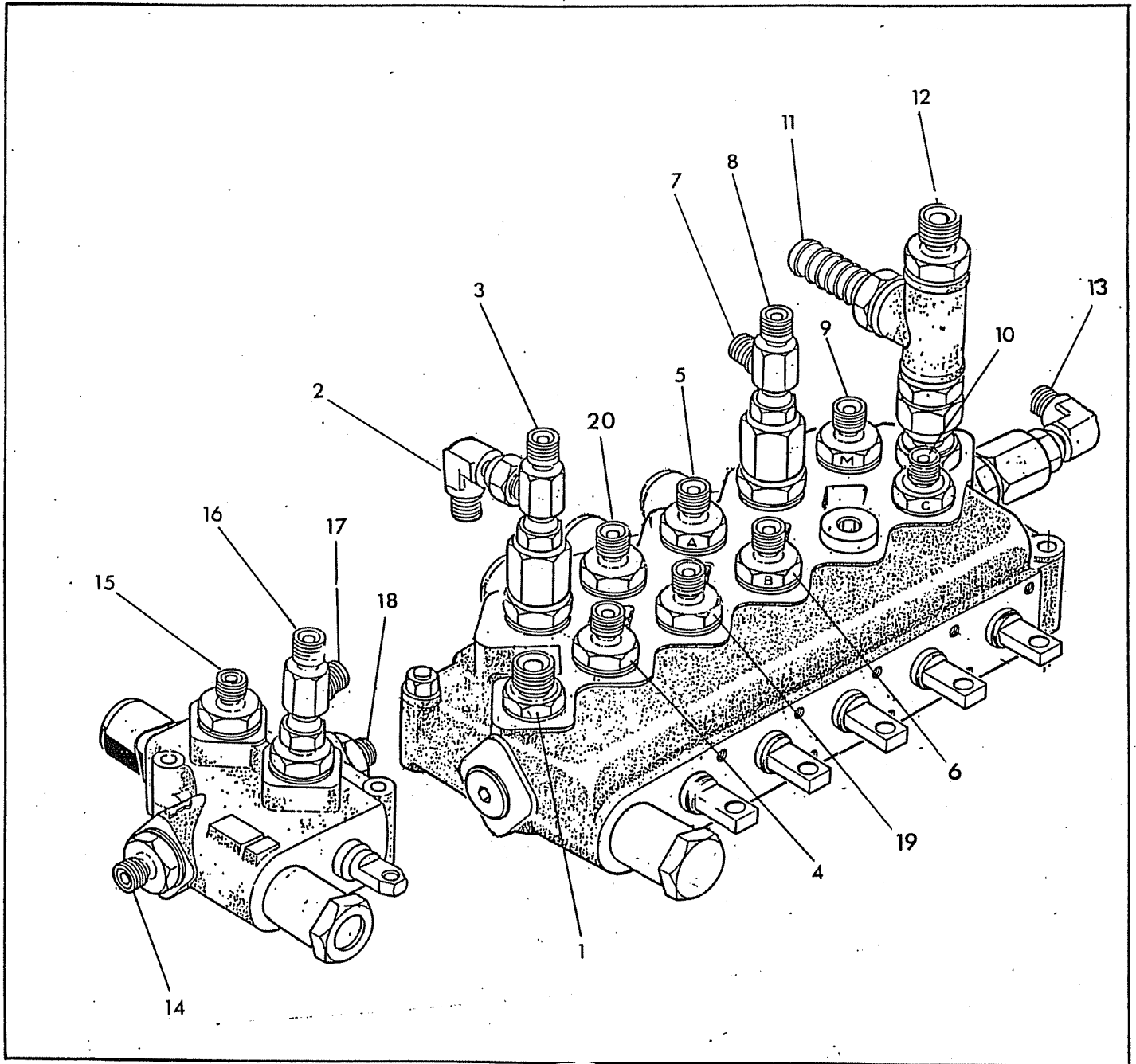

- | | |
|---------------------|---------------------------|
| 1. Supply from pump | 11. Return to Rotor valve |
| 2. Slew base | 12. Connection 18 |
| 3. Connection 14 | 13. Lift gland |
| 4. Connection 16 | 14. Connection 3 |
| 5. Reach gland | 15. Connection 8 |
| 6. Reach base | 16. Connection 4 |
| 7. Lift base | 17. Slew gland |
| 8. Connection 15 | 18. Connection 12 |
| 9. Angle gland | 19. Tele base |
| 10. Angle base | 20. Tele gland |

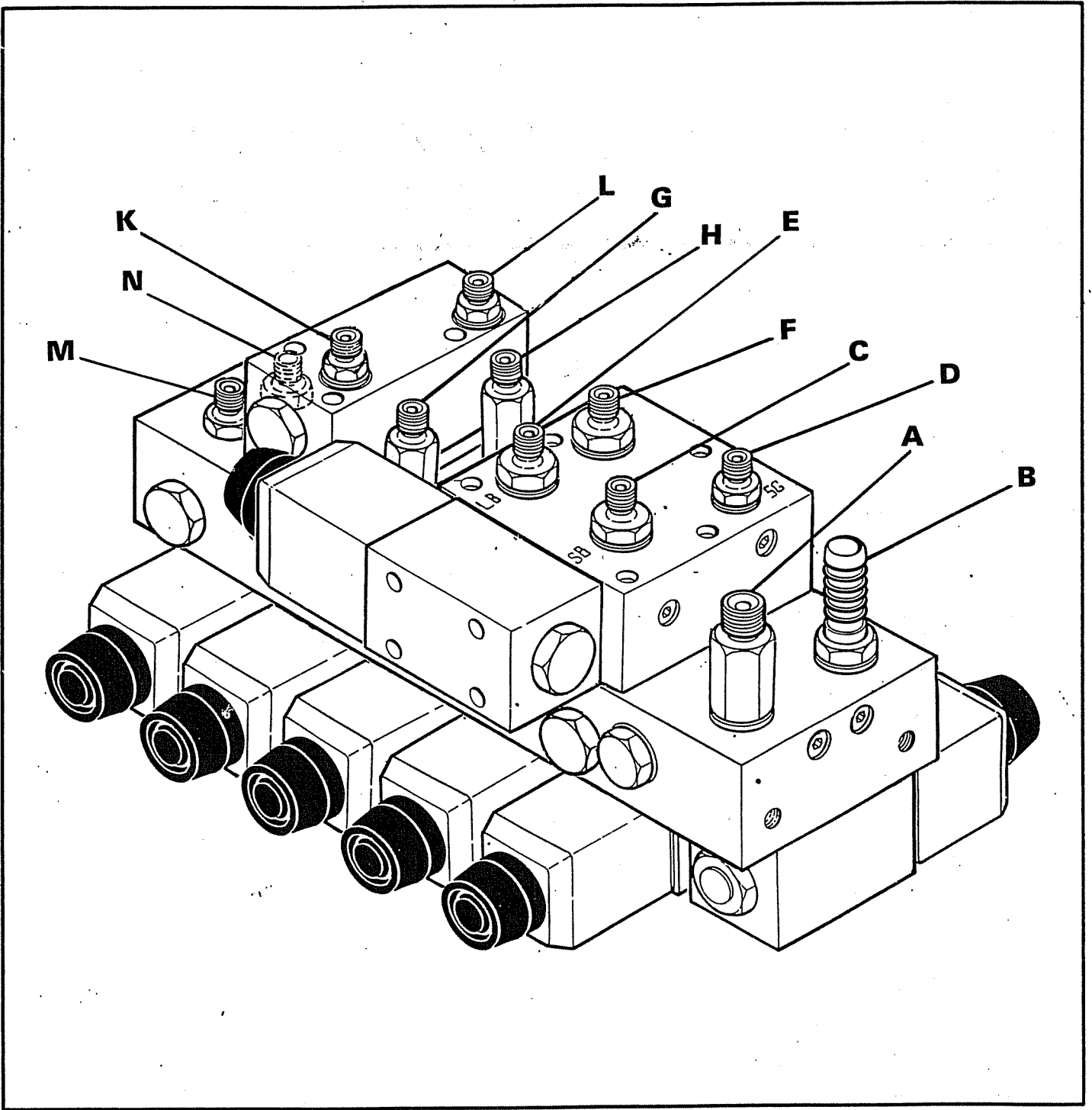

MAIN VALVE - 2050 E /std arm and tele:

A - Supply

B - Return to Rotor control valve

C - Slew base

D - Slew gland

E - Lift base

F - Lift gland

G - Tele base (if fitted)

H - Tele gland (if fitted)

K - Angle base

L - Angle gland

M - Reach base

N - Reach gland

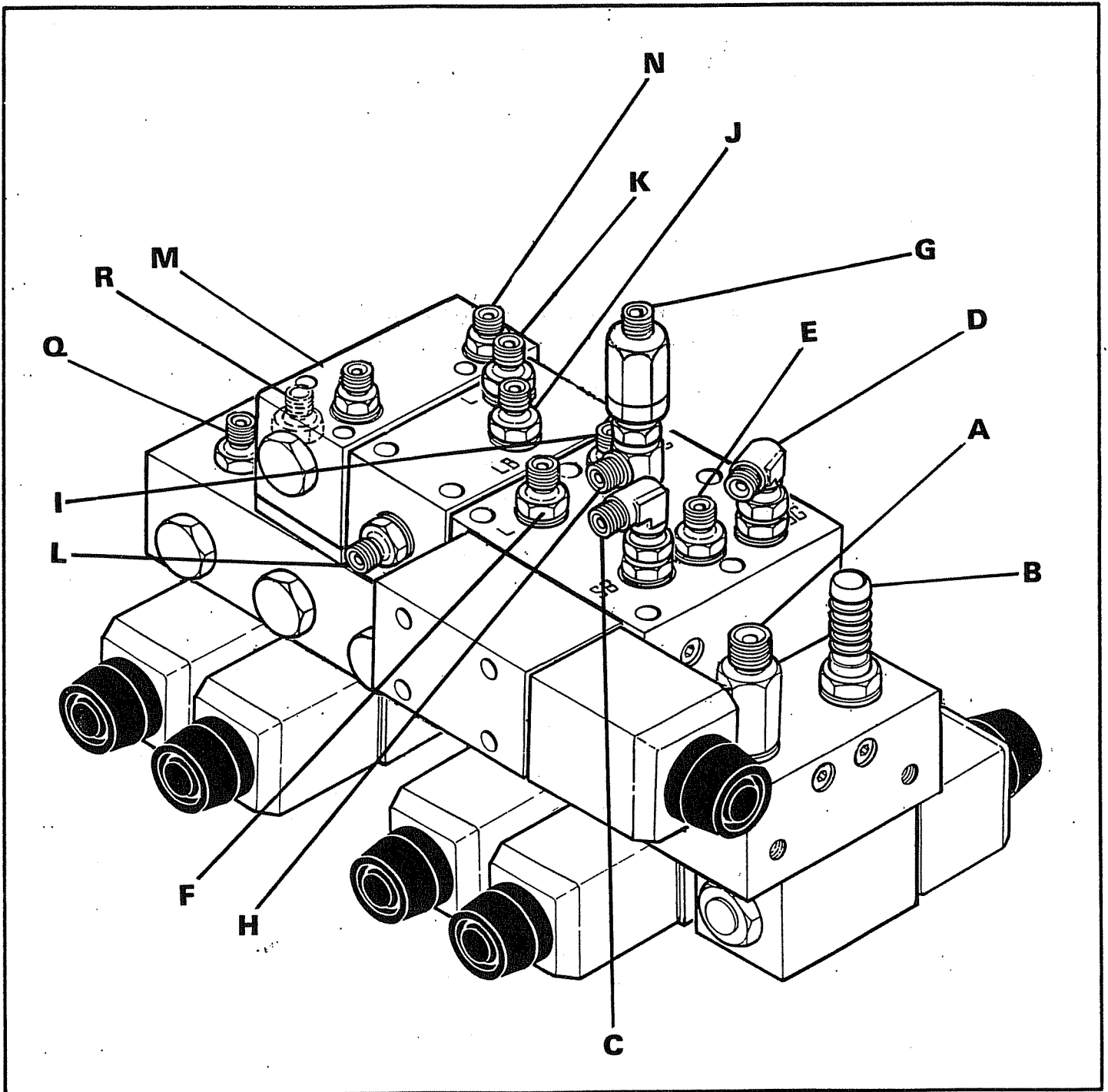

MAIN VALVE - 2050 Mid cut

A - Supply

C - Slew Base

E - Breakaway gland

G - Breakaway base

I - Lift gland

K - Connection F

M - Angle base

Q - Reach base

B - Return to Rotor control valve

D - Slew gland

F - Connection K

H - Connection L

J - Lift base

L - Connection H

N - Angle gland

R - Reach gland

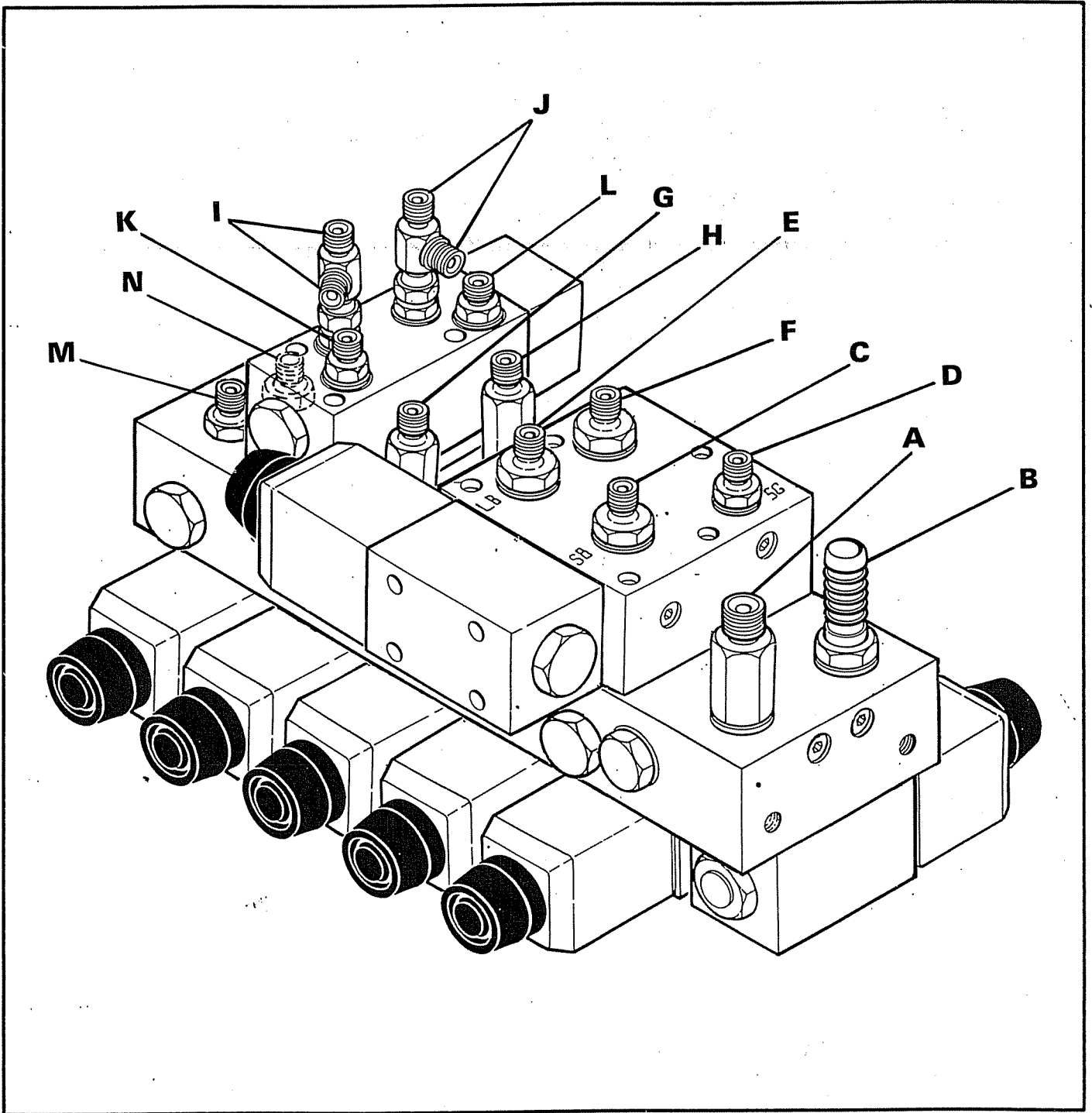

MAIN VALVE - 2050E AHC/std arm and tele

- | | |
|----------------------------------|--|
| A - Supply | B - Return to Rotor control valve |
| C - Slew base | D - Slew gland |
| E - Lift base | F - Lift gland |
| G - Tele base (if fitted) | H - Tele gland (if fitted) |
| I - Compensator bases | J - Compensator glands |
| K - Angle base | L - Angle gland |
| M - Reach base | N - Reach gland |

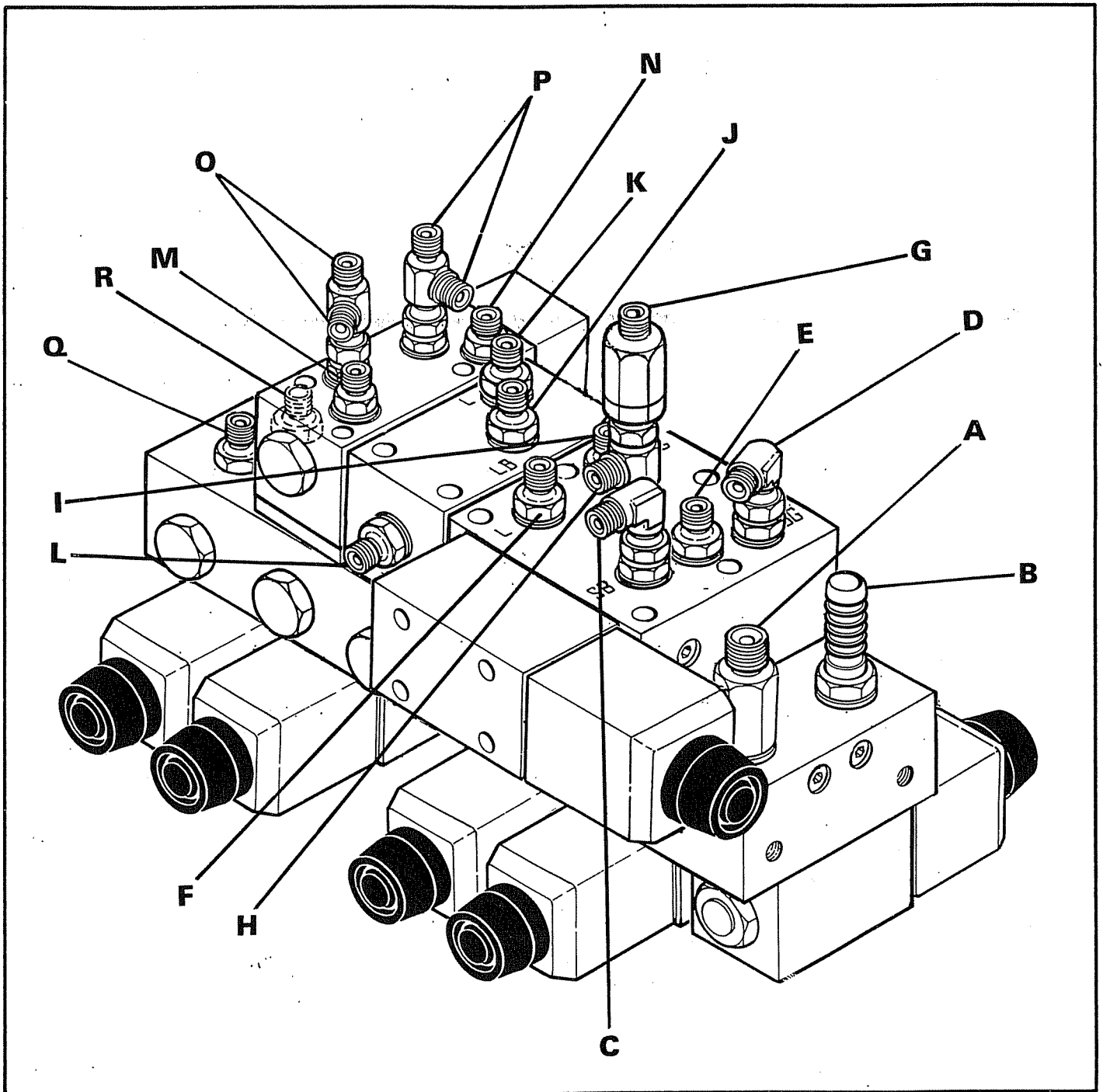

MAIN VALVE - 2050 Mid cut AHC

A - Supply

C - Slew Base

E - Breakaway gland

G - Breakaway base

I - Lift gland

K - Connection F

M - Angle base

O - Compensator bases

Q - Reach base

B - Return to Rotor control valve

D - Slew gland

F - Connection K

H - Connection L

J - Lift base

L - Connection H

N - Angle gland

P - Compensator glands

R - Reach gland

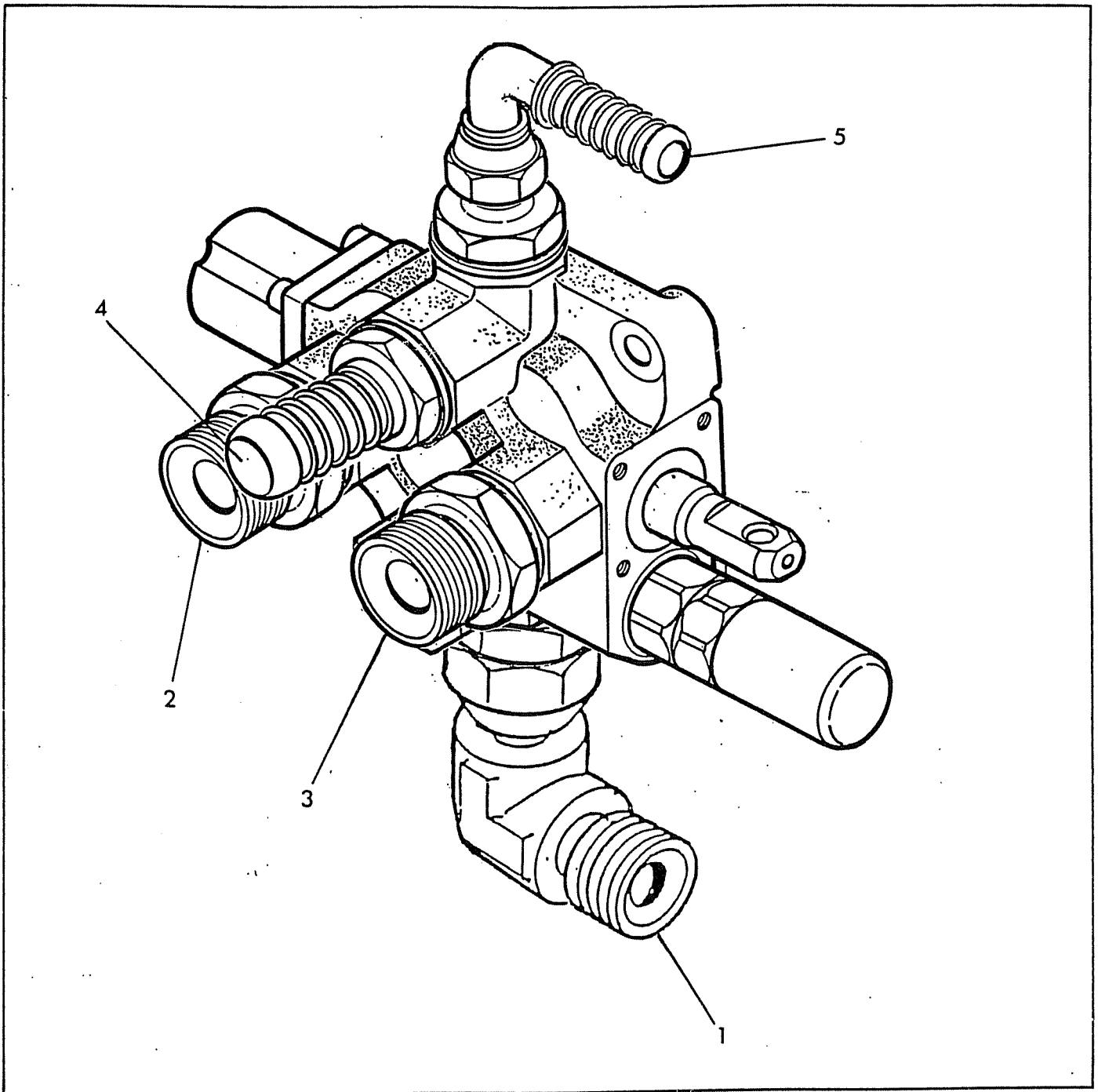

HOSE CONNECTIONS - ROTOR CONTROL VALVE

- | | |
|----------------------|------------------------------|
| 1. Supply from pump | 4. Return to tank |
| 2. Flail Motor lower | 5. Return from control valve |
| 3. Flail Motor Upper | |



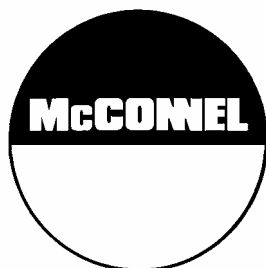

McConnel Limited, Temeside Works, Ludlow, Shropshire SY8 1JL. England.
Telephone: 01584 873131. Facsimile: 01584 876463. www.mcconnel.com