

Publication 649
April 2010
Part No. 22674.49
Revision: 08.10.12



ECON

HEDGEMASTER Mk3

Mid-Mounted Hedgecutter/Mower

Operator Manual



IMPORTANT

VERIFICATION OF WARRANTY REGISTRATION



DEALER WARRANTY INFORMATION & REGISTRATION VERIFICATION

It is imperative that the selling dealer registers this machine with McConnel Limited before delivery to the end user – failure to do so may affect the validity of the machine warranty.

To register machines go to the McConnel Limited web site at www.mccommel.com, log onto 'Dealer Inside' and select the 'Machine Registration button' which can be found in the Service Section of the site. Confirm to the customer that the machine has been registered in the section below.

Should you experience any problems registering a machine in this manner please contact the McConnel Service Department on 01584 875848.

Registration Verification

Dealer Name:
Dealer Address:
Customer Name:
Date of Warranty Registration:/...../..... Dealer Signature:

NOTE TO CUSTOMER / OWNER

Please ensure that the above section above has been completed and signed by the selling dealer to verify that your machine has been registered with McConnel Limited.

IMPORTANT: During the initial 'bedding in' period of a new machine it is the customer's responsibility to regularly inspect all nuts, bolts and hose connections for tightness and re-tighten if required. New hydraulic connections occasionally weep small amounts of oil as the seals and joints settle in – where this occurs it can be cured by re-tightening the connection – *refer to torque settings chart below*. The tasks stated above should be performed on an hourly basis during the first day of work and at least daily thereafter as part of the machines general maintenance procedure.

CAUTION: DO NOT OVER TORQUE HYDRAULIC FITTINGS AND HOSES

TORQUE SETTINGS FOR HYDRAULIC FITTINGS

HYDRAULIC HOSE ENDS		
BSP	Setting	Metric
1/4"	18 Nm	19 mm
3/8"	31 Nm	22 mm
1/2"	49 Nm	27 mm
5/8"	60 Nm	30 mm
3/4"	80 Nm	32 mm
1"	125 Nm	41 mm
1.1/4"	190 Nm	50 mm
1.1/2"	250 Nm	55 mm
2"	420 Nm	70 mm

PORT ADAPTORS WITH BONDED SEALS		
BSP	Setting	Metric
1/4"	34 Nm	19 mm
3/8"	47 Nm	22 mm
1/2"	102 Nm	27 mm
5/8"	122 Nm	30 mm
3/4"	149 Nm	32 mm
1"	203 Nm	41 mm
1.1/4"	305 Nm	50 mm
1.1/2"	305 Nm	55 mm
2"	400 Nm	70 mm

WARRANTY POLICY

WARRANTY REGISTRATION

All machines must be registered, by the selling dealer with McConnel Ltd, before delivery to the end user. On receipt of the goods it is the buyer's responsibility to check that the Verification of Warranty Registration in the Operator's Manual has been completed by the selling dealer.

1. LIMITED WARRANTIES

1.01. *All mounted machines supplied by McConnel Ltd are warranted to be free from defects in material and workmanship from the date of sale to the original purchaser for a period of 12 months, unless a different period is specified.*

All Self Propelled Machines supplied by McConnel Ltd are warranted to be free from defects in material and workmanship from the date of sale to the original purchaser for a period of 12 months or 1500 hours. Engine warranty will be specific to the Manufacturer of that unit.

1.02. *All spare parts supplied by McConnel Ltd and purchased by the end user are warranted to be free from defects in material and workmanship from the date of sale to the original purchaser for a period of 6 months. All parts warranty claims must be supported by a copy of the failed part invoice to the end user. We cannot consider claims for which sales invoices are not available.*

1.03. *The warranty offered by McConnel Ltd is limited to the making good by repair or replacement for the purchaser any part or parts found, upon examination at its factory, to be defective under normal use and service due to defects in material or workmanship. Returned parts must be complete and unexamined. Pack the component(s) carefully so that any transit damage is avoided. All ports on hydraulic items should be drained of oil and securely plugged to prevent seepage and foreign body ingress. Certain other components, electrical items for example, may require particular care when packing to avoid damage in transit.*

1.04. *This warranty does not extend to any product from which McConnel Ltd's serial number plate has been removed or altered.*

1.05. *The warranty policy is valid for machines registered in line with the terms and conditions detailed and on the basis that the machines do not extend a period of 24 months or greater since their original purchase date, that is the original invoice date from McConnel Limited. Machines that are held in stock for more than 24 months cannot be registered for warranty.*

1.06. *This warranty does not apply to any part of the goods, which has been subjected to improper or abnormal use, negligence, alteration, modification, fitment of non-genuine parts, accident damage, or damage resulting from contact with overhead power lines, damage caused by foreign objects (e.g. stones, iron, material other than vegetation), failure due to lack of maintenance, use of incorrect oil or lubricants, contamination of the oil, or which has served its normal life. This warranty does not apply to any expendable items such as blades, belts, clutch linings, filter elements, flails, flap kits, skids, soil engaging parts, shields, guards, wear pads, pneumatic tyres or tracks.*

1.07. *Temporary repairs and consequential loss - i.e. oil, downtime and associated parts are specifically excluded from the warranty.*

1.08. *Warranty on hoses is limited to 12 months and does not include hoses which have suffered external damage. Only complete hoses may be returned under warranty, any which have been cut or repaired will be rejected.*

1.09. *Machines must be repaired immediately a problem arises. Continued use of the machine after a problem has occurred can result in further component failures, for which McConnel Ltd cannot be held liable, and may have safety implications.*

1.10. *If in exceptional circumstances a non McConnel Ltd part is used to effect a repair, warranty reimbursement will be at no more than McConnel Ltd's standard dealer cost for the genuine part.*

- 1.11. *Except as provided herein, no employee, agent, dealer or other person is authorised to give any warranties of any nature on behalf of McConnell Ltd.*
- 1.12. *For machine warranty periods in excess of 12 months the following additional exclusions shall apply:*
 - 1.12.1. *Hoses, exposed pipes and hydraulic tank breathers.*
 - 1.12.2. *Filters.*
 - 1.12.3. *Rubber mountings.*
 - 1.12.4. *External electric wiring.*
 - 1.12.5. *Bearings and seals*
 - 1.12.6. *External Cables, Linkages*
 - 1.12.7. *Loose/Corroded Connections, Light Units, LED's*
 - 1.12.8. *Comfort items such as Operator Seat, Ventilation, Audio Equipment*
- 1.13. *All service work, particularly filter changes, must be carried out in accordance with the manufacturer's service schedule. Failure to comply will invalidate the warranty. In the event of a claim, proof of the service work being carried out may be required.*
- 1.14. *Repeat or additional repairs resulting from incorrect diagnosis or poor quality previous repair work are excluded from warranty.*

NB Warranty cover will be invalid if any non-genuine parts have been fitted or used. Use of non-genuine parts may seriously affect the machine's performance and safety. McConnell Ltd cannot be held responsible for any failures or safety implications that arise due to the use of non-genuine parts.

2. REMEDIES AND PROCEDURES

- 2.01. *The warranty is not effective unless the Selling Dealer registers the machine, via the McConnell web site and confirms the registration to the purchaser by completing the confirmation form in the operator's manual.*
- 2.02. *Any fault must be reported to an authorised McConnell Ltd dealer as soon as it occurs. Continued use of a machine, after a fault has occurred, can result in further component failure for which McConnell Ltd cannot be held liable.*
- 2.03. *Repairs should be undertaken within two days of the failure. Claims submitted for repairs undertaken more than 2 weeks after a failure has occurred, or 2 days after the parts were supplied will be rejected, unless the delay has been authorised by McConnell Ltd. Please note that failure by the customer to release the machine for repair will not be accepted as a reason for delay in repair or submitting warranty claims.*
- 2.04. *All claims must be submitted, by an authorised McConnell Ltd Service Dealer, within 30 days of the date of repair.*
- 2.05. *Following examination of the claim and parts, McConnell Ltd will pay, at their discretion, for any valid claim the invoiced cost of any parts supplied by McConnell Ltd and appropriate labour and mileage allowances if applicable.*
- 2.06. *The submission of a claim is not a guarantee of payment.*
- 2.07. *Any decision reached by McConnell Ltd. is final.*

3. LIMITATION OF LIABILITY

- 3.01. *McConnell Ltd disclaims any express (except as set forth herein) and implied warranties with respect to the goods including, but not limited to, merchantability and fitness for a particular purpose.*
- 3.02. *McConnell Ltd makes no warranty as to the design, capability, capacity or suitability for use of the goods.*
- 3.03. *Except as provided herein, McConnell Ltd shall have no liability or responsibility to the purchaser or any other person or entity with respect to any liability, loss, or damage caused or alleged to be caused directly or indirectly by the goods including, but not limited to, any indirect, special, consequential, or incidental damages resulting from the use or operation of the goods or any breach of this warranty. Notwithstanding the above limitations and warranties, the manufacturer's liability hereunder for damages incurred by the purchaser or others shall not exceed the price of the goods.*
- 3.04. *No action arising out of any claimed breach of this warranty or transactions under this warranty may be brought more than one (1) year after the cause of the action has occurred.*

4. MISCELLANEOUS

- 4.01. McConnel Ltd may waive compliance with any of the terms of this limited warranty, but no waiver of any terms shall be deemed to be a waiver of any other term.*
- 4.02. If any provision of this limited warranty shall violate any applicable law and is held to be unenforceable, then the invalidity of such provision shall not invalidate any other provisions herein.*
- 4.03. Applicable law may provide rights and benefits to the purchaser in addition to those provided herein.*

McConnel Limited



DECLARATION OF CONFORMITY

Conforming to EU Machinery Directive 2006/42/EC

We,

McCONNEL LIMITED, Temeside Works, Ludlow, Shropshire SY8 1JL, UK

Hereby declare that:

The Product; *Tractor Mounted Hedgecutter / Grass Mower*

Product Code; *ECON*

Serial No. & Date Type

Manufactured in; *United Kingdom*

Complies with the required provisions of the Machinery Directive 2006/42/EC
The machinery directive is supported by the following harmonized standards;

- BS EN ISO 12100 (2010) Safety of machinery – General principles for design – Risk assessment and risk reduction.
- BS EN 349 (1993) + A1 (2008) Safety of machinery - Minimum distances to avoid the entrapment with human body parts.
- BS EN ISO 14120 (2015) Safety of machinery - Guards general requirements for the design and construction of fixed and movable guards.
- BS EN 4413 (2010) Hydraulic fluid power. Safety requirements for systems and their components.

McCONNEL LIMITED operates an ISO 9001:2008 quality management system, certificate number: FM25970.

This system is continually assessed by the;

British Standards Institution (BSI), Beech House, Milton Keynes, MK14 6ES, UK
BSI is accredited by UK Accreditation Service, accreditation number: UKAS 003.
The EC declaration only applies if the machine stated above is used in accordance with the operating instructions.

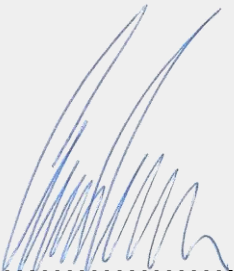
Signed  *Responsible Person*
CHRISTIAN DAVIES on behalf of McCONNEL LIMITED

Status: *General Manager*

Date: *January 2018*

POWER ARM INSPECTION AND MAINTENANCE

A daily equipment inspection of the tractor and mower should be conducted before the equipment is used. You may use the inspection sheets to assist with these daily inspections. Any damaged or missing guards should be repaired or replaced before operating the mower. Failure to repair the damaged shield can result in objects being thrown from the mower and possibly hitting the operator or bystander.

Inspect the Mower for Safe Operating Condition

- Make sure the driveline guards and shielding are in place and in good repair.
- Inspect the flexible thrown object shielding to assure that they are in place on the front and rear of the mower head and in good repair. Repair or replace any damaged or missing thrown object shields.
- Ensure the mower cutting height is set high enough to reduce the possibility of the mower blades contacting the ground. Actual height will be dependent on the ground conditions. Increase the height when working in rough or undulating conditions.
- Inspect for broken, chipped, bent, missing, or severely worn blades. Replace damaged blades before operating the mower. Ensure the blade retaining bolts and fasteners are secure and tight.
- Ensure all head bolts and nuts are tight.
- Lubricate the driveline universal joints and telescoping members daily.
- Grease the rotor and roller bearings and inspect their condition.
- Inspect for any oil leaks or damaged hoses
- Inspect for worn or damaged decals and safety instructions. Replace unreadable, damaged or missing safety decals.
- Follow the operator's manual(s) inspection and maintenance instructions for lubricating parts, and keeping thrown object shielding, driveline guards, rotating parts shields, mower blades and decals in good repair.

Inspect the Tractor for Safe Operating Condition:

- Inspect the controls, lights, SMVs (Slow Moving Vehicle sign), seat belts, and ROPS to assure that they are in place and in good working order.
- Be sure the tires, wheels, lug bolts/nuts are in good condition.
- Make sure the tractor brakes and steering are in proper operating condition.
- Follow the operator's manual(s) inspection and maintenance procedures for keeping the tractor in good and safe condition before operating.

The inspection sheet on the following page should be kept in this book as a record. A second sheet is included for you to cut out and photocopy or the inspection sheets can be downloaded from our website at;

<http://www.mcconnel.com/support/aftersales/default.aspx?nav=After Sales>



POWER ARM PRE-OPERATION Inspection

Power Arm ID _____ Date: _____ Shift: _____

WARNING



Before conducting the inspection, make sure the tractor engine is off, the key removed, all rotation has stopped and the tractor is in park with the parking brake engaged. Make sure the mower head is resting on the ground or is securely blocked up and supported and all hydraulic pressure has been relieved.

Item	Condition at start of shift	Specific Comments if not O.K.
The Operator's Manual is in the Canister on the mower		
All Warning Decals are in place, clean and legible		
All Lights are clean and working		
The Mounting frame bolts are in place and tight		
The Arm pivot pins are tight and correctly secured		
There are no cracks in the arms		
The Hyd. Cylinder pins are tight and correctly secured		
The Hyd Cylinder hose connections are tight		
The Hyd. Pump hose connections are tight		
The Hyd. Valve hose connections are tight		
The Hyd. Valve controls function properly		
There are no damaged hoses		
The Oil level is to the green mark on the tank sight glass		
There is no evidence of Hydraulic oil leaks		
Flails are not missing, chipped, broken or excessively worn		
The Flail bolts are tight		
The Front & Rear Flaps are fitted and in good condition		
The Front hood is in place and in good condition		
The Wire Trap is in good condition		
The Skid shoes are in good condition & tight		
There are no cracks or holes in flail casing		
The Hyd. motor mounting bolts are tight		
All Flail Head Nuts and Bolts are tight		
The Rotor Bearings are in good condition and greased		
The Roller bearings are in good condition and greased		
The drive line Shaft guard is in good condition		
The drive line shaft guard is correctly secured		
Controls are securely mounted in the cab		
With engine running check arm operation		
Have a spare pack of flails, bushes, bolts and nuts		

Operators Signature: _____

DO NOT OPERATE an UNSAFE TRACTOR or MOWER



TRACTOR PRE-OPERATION Inspection

Power Arm ID _____ Date: _____ Shift: _____

WARNING



Before conducting the inspection, make sure the tractor engine is off, the key is removed all rotation has stopped and the tractor is in park with the parking brake engaged. Any implement attached to the tractor is firmly on the ground.

Item	Condition at start of shift	Specific Comments if not O.K.
The flashing lights function properly.		
All lights are clean and working correctly		
All cab windows are clean and wipers working correctly		
The SMV sign, where required, is clean and visible.		
The tyres are in good condition with correct pressure.		
The wheel nuts are tight.		
The tractor brakes are in good condition.		
The steering linkage is in good condition.		
There are no visible oil leaks.		
The hydraulic controls function properly.		
The ROPS or ROPS cab is in good condition.		
The seatbelt is in place and in good condition.		
The 3-point hitch is in good condition.		
The drawbar/pick up hook is secure & in good condition		
The PTO master shield is in place.		
The engine oil level is full.		
The brake fluid level is full.		
The power steering fluid level is full.		
The fuel level is adequate.		
The engine coolant fluid level is full.		
The radiator & oil cooler are free of debris.		
The air filter is in good condition		

Operators Signature: _____

DO NOT OPERATE an UNSAFE TRACTOR or MOWER



POWER ARM PRE-OPERATION Inspection

Power Arm ID _____ Date: _____ Shift: _____

WARNING



Before conducting the inspection, make sure the tractor engine is off, the key removed, all rotation has stopped and the tractor is in park with the parking brake engaged. Make sure the mower head is resting on the ground or is securely blocked up and supported and all hydraulic pressure has been relieved.

Item	Condition at start of shift	Specific Comments if not O.K.
The Operator's Manual is in the Canister on the mower		
All Warning Decals are in place, clean and legible		
All Lights are clean and working		
The Mounting frame bolts are in place and tight		
The Arm pivot pins are tight and correctly secured		
There are no cracks in the arms		
The Hyd. Cylinder pins are tight and correctly secured		
The Hyd Cylinder hose connections are tight		
The Hyd. Pump hose connections are tight		
The Hyd. Valve hose connections are tight		
The Hyd. Valve controls function properly		
There are no damaged hoses		
The Oil level is to the green mark on the tank sight glass		
There is no evidence of Hydraulic oil leaks		
Flails are not missing, chipped, broken or excessively worn		
The Flail bolts are tight		
The Front & Rear Flaps are fitted and in good condition		
The Front hood is in place and in good condition		
The Wire Trap is in good condition		
The Skid shoes are in good condition & tight		
There are no cracks or holes in flail casing		
The Hyd. motor mounting bolts are tight		
All Flail Head Nuts and Bolts are tight		
The Rotor Bearings are in good condition and greased		
The Roller bearings are in good condition and greased		
The drive line Shaft guard is in good condition		
The drive line shaft guard is correctly secured		
Controls are securely mounted in the cab		
With engine running check arm operation		
Have a spare pack of flails, bushes, bolts and nuts		

Operators Signature: _____

DO NOT OPERATE an UNSAFE TRACTOR or MOWER



TRACTOR PRE-OPERATION Inspection

Power Arm ID _____ Date: _____ Shift: _____

WARNING



Before conducting the inspection, make sure the tractor engine is off, the key is removed all rotation has stopped and the tractor is in park with the parking brake engaged. Any implement attached to the tractor is firmly on the ground.

Item	Condition at start of shift	Specific Comments if not O.K.
The flashing lights function properly.		
All lights are clean and working correctly		
All cab windows are clean and wipers working correctly		
The SMV sign, where required, is clean and visible.		
The tyres are in good condition with correct pressure.		
The wheel nuts are tight.		
The tractor brakes are in good condition.		
The steering linkage is in good condition.		
There are no visible oil leaks.		
The hydraulic controls function properly.		
The ROPS or ROPS cab is in good condition.		
The seatbelt is in place and in good condition.		
The 3-point hitch is in good condition.		
The drawbar/pick up hook is secure & in good condition		
The PTO master shield is in place.		
The engine oil level is full.		
The brake fluid level is full.		
The power steering fluid level is full.		
The fuel level is adequate.		
The engine coolant fluid level is full.		
The radiator & oil cooler are free of debris.		
The air filter is in good condition		

Operators Signature: _____

DO NOT OPERATE an UNSAFE TRACTOR or MOWER



For Safety and Performance ...

ALWAYS READ THIS BOOK FIRST

McCONEl LIMITED

**Temeside Works
Ludlow
Shropshire
England**

**Telephone: 01584 873131
www.mcconel.com**

NOISE STATEMENT

The equivalent daily personal noise exposure from this machine measured at the operators' ear is within the range 78 – 85 dB, these figures apply to a normal distribution of use where the noise fluctuates between zero and maximum. The figures assume that the machine is fitted to a tractor with a 'quiet' cab with the windows closed in a generally open environment. We recommend that the windows are kept closed. With the cab rear window open the equivalent daily personal noise exposure will increase to a figure within the range 82 – 88 dB. At equivalent daily noise exposure levels of between 85 – 90 dB ear protection is recommended – it should be used if any window is left open.

LIST OF CONTENTS

	<i>Page No.</i>
General Information	1
Features & Specifications	2
Safety Information	3
Tractor Requirements	7
General Tractor Preparation	8
Hydraulic Oil	9
Operating Instructions	10
Fitting Instructions	13
PTO Driveshaft Installation	17
Controls	18
Operating Principals	20
Electric Switchbox Controls	21
Monolever Controls	25
V4 Proportional Controls	29
Preparation & Precautions	42
Emergency Stopping	43
Operating Speeds	44
Safety Breakaway	45
EDS	45
Lift Float (Option for Ground Work)	46
Hedgecutting Procedure	47
Hazards & Dangers	48
Overhead Power Lines	49
Flail Types	51
Maintenance Information	53

GENERAL INFORMATION

Always read this manual before fitting or operating the machine – whenever any doubt exists contact your dealer or the McConnel Service Department for advice and assistance.

Use only McConnel Genuine Service Parts on McConnel Equipment and Machines

DEFINITIONS – *The following definitions apply throughout this manual:*

WARNING

An operating procedure, technique etc., which –
can result in personal injury or loss of life if not observed carefully.

CAUTION

An operating procedure, technique etc., which –
can result in damage to either machine or equipment if not observed carefully.

NOTE

An operating procedure, technique etc., which –
is considered essential to emphasis.

LEFT AND RIGHT HAND

This term is applicable to the machine when attached to the tractor and is viewed
from the rear – this also applies to tractor references.

MACHINE & DEALER INFORMATION

Record the Serial Number of your machine on this page and always quote this number when ordering parts. Whenever information concerning the machine is requested remember also to state the make and model of tractor to which the machine is fitted.

Machine Serial Number:	Installation Date:
Machine Model details:	
Dealer Name:	
Dealer Address:	
Dealer Telephone No:	
Dealer Email Address:	

FEATURES & SPECIFICATIONS

ECON Hedgemaster Mk3

- 6.4m Reach
- Mid Mounted
- Hydraulic Safety Breakaway
- Unrivalled Arm Geometry
- Excellent Cutting Visibility
- High Capacity Oil Tank (227 Litre)
- 45HP Hydraulics
- Choice of Control Systems
- Choice of Attachments

Optional Extras

- Lift Float Kit
- Oil Cooler
- Road Lighting Kit

Reach Dimensions

A. 6.4m (21'0")

B. 6.2m (20'3")

C. 4.26m (14'0")

D. 3.5m (11'5")

E. 5.0m (16'5")

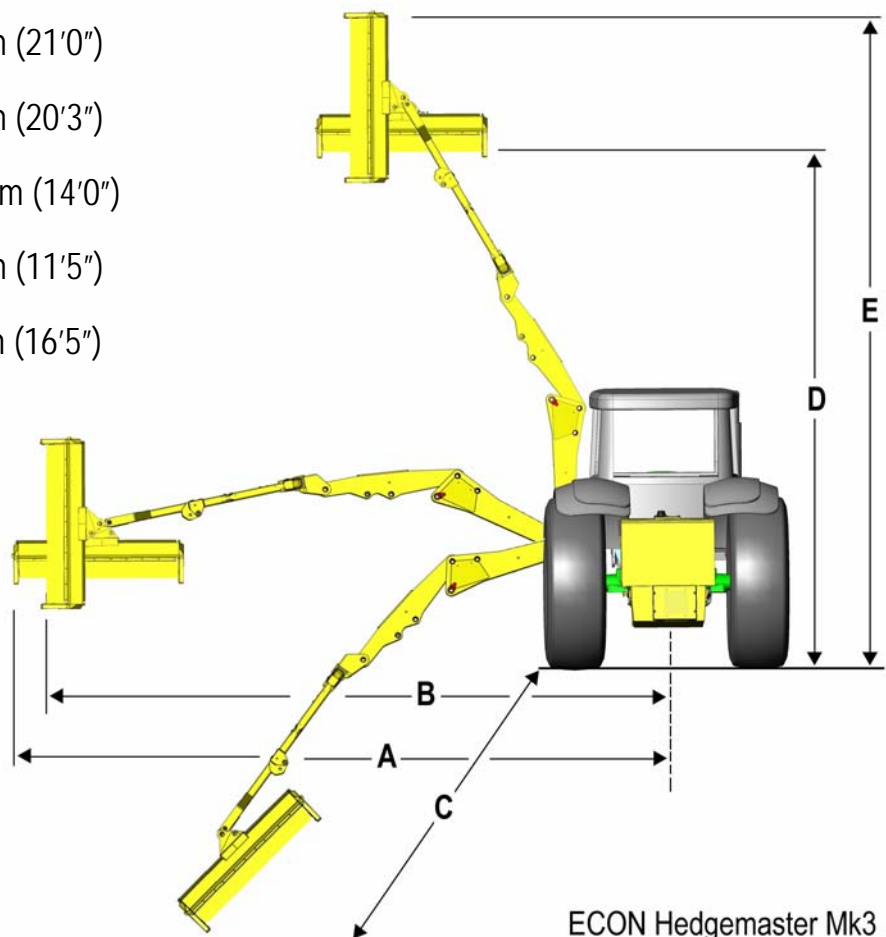



This machine has the potential to be extremely dangerous - in the wrong hands it can kill or maim; It is therefore imperative that both owner and operator of the machine reads and understands the following section to ensure they are fully aware of the dangers that do, or may exist, and their responsibilities surrounding the use and operation of the machine.

The operator of this machine is responsible not only for their own safety but equally for the safety of others who may come into the close proximity of the machine, as the owner you are responsible for both.

When the machine is not in use the cutting head should be lowered to rest on the ground. In the event of any fault being detected with the machine's operation it must be stopped immediately and not used again until the fault has been corrected by a qualified technician.

POTENTIAL SIGNIFICANT DANGERS ASSOCIATED WITH THE USE OF THIS MACHINE:

- ▲ *Being hit by debris thrown by rotating components.*
- ▲ *Being hit by machine parts ejected through damage during use.*
- ▲ *Being caught on a rotating power take-off (PTO) shaft.*
- ▲ *Being caught in other moving parts i.e.: belts, pulleys and cutting heads.*
- ▲ *Electrocution from Overhead Power Lines (by contact with or 'flashover' from).*
- ▲ *Being hit by cutting heads or machine arms as they move.*
- ▲ *Becoming trapped between tractor and machine when hitching or unhitching.*
- ▲ *Tractor overbalancing when machine arm is extended.*
- ▲ *Injection of high-pressure oil from hydraulic hoses or couplings.*
- ▲ *Machine overbalancing when freestanding (out of use).*
- ▲ *Road traffic accidents due to collision or debris on the road.*

BEFORE USING THIS MACHINE YOU MUST:

- ▲ *Ensure you read all sections of the operator handbook.*
- ▲ *Ensure the operator is, or has been, properly trained to use the machine.*
- ▲ *Ensure the operator has been issued with and reads the operator handbook.*
- ▲ *Ensure the operator understands and follows the instructions in operator handbook.*
- ▲ *Ensure the tractor front, rear and sides are fitted with metal mesh or polycarbonate guards of suitable size and strength to protect the operator against thrown debris or parts.*
- ▲ *Ensure tractor guards are fitted correctly, are undamaged and kept properly maintained.*
- ▲ *Ensure that all machine guards are in position, are undamaged, and are kept maintained in accordance with the manufacturer's recommendations.*
- ▲ *Ensure flails and their fixings are of a type recommended by the manufacturer, are securely attached and that none are missing or damaged.*
- ▲ *Ensure hydraulic pipes are carefully and correctly routed to avoid damage by chaffing, stretching or pinching and that they are held in place with the correct fittings.*
- ▲ *Always follow the manufacturer's instructions for attachment and removal of the machine from the tractor.*
- ▲ *Check that the machine fittings and couplings are in good condition.*
- ▲ *Ensure the tractor meets the minimum weight recommendations of the machine's manufacturer and that ballast is used as necessary.*
- ▲ *Always inspect the work area thoroughly before starting to note obstacles and remove wire, bottles, cans and other debris.*
- ▲ *Use clear suitably sized warning signs to alert others to the nature of the machine working within that area. Signs should be placed at both ends of the work site. (It is recommended that signs used are of a size and type specified by the Department of Transport and positioned in accordance with their, and the Local Highways Authority, guidelines).*
- ▲ *Ensure the operator is protected from noise. Ear defenders should be worn and tractor cab doors and windows must be kept closed. Machine controls should be routed through proprietary openings in the cab to enable all windows to be shut fully.*
- ▲ *Always work at a safe speed taking account of the conditions i.e.: terrain, highway proximity and obstacles around and above the machine. Extra special attention should be applied to Overhead Power Lines. Some of our machines are capable of reach in excess of 8 metres (26 feet) this means they have the potential to well exceed, by possibly 3 metres (9' 9"), the lowest legal minimum height of 5.2 metres from the ground for 11,000 and 33,000 volt power lines. It cannot be stressed enough the dangers that surround this capability, it is therefore vital that the operator is fully aware of the maximum height and reach of the machine, and that they are fully conversant with all aspects regarding the safe minimum distances that apply when working with machines in close proximity to Power Lines. (Further information on this subject can be obtained from the Health & Safety Executive or your Local Power Company).*

- ▲ *Always disengage the machine, kill the tractor engine, remove and pocket the key before dismounting for any reason.*
- ▲ *Always clear up all debris left at the work area, it may cause hazard to others.*
- ▲ *Always ensure when you remove your machine from the tractor that it is left in a safe and stable position using the stands and props provided and secured if necessary.*

WHEN NOT TO USE THIS MACHINE:

- ▲ *Never attempt to use this machine if you have not been trained to do so.*
- ▲ *Never use a machine until you have read and understood the operator handbook, are familiar with it, and practiced the controls.*
- ▲ *Never use a machine that is poorly maintained.*
- ▲ *Never use a machine if guards are missing or damaged.*
- ▲ *Never use a machine on which the hydraulic system shows signs of wear or damage.*
- ▲ *Never fit, or use, a machine on a tractor that does not meet the manufacturer's minimum specification level.*
- ▲ *Never use a machine fitted to a tractor that does not have suitable front, rear and side(s) cab guarding made of metal mesh or polycarbonate.*
- ▲ *Never use the machine if the tractor cab guarding is damaged, deteriorating or badly fitted.*
- ▲ *Never turn a machine cutting head to an angle that causes debris to be ejected towards the cab.*
- ▲ *Never start or continue to work a machine if people are nearby or approaching - Stop and wait until they are at a safe distance before continuing. WARNING: Some cutting heads may continue to 'freewheel' for up to 40 seconds after being stopped.*
- ▲ *Never attempt to use a machine on materials in excess of its capability.*
- ▲ *Never use a machine to perform a task it has not been designed to do.*
- ▲ *Never operate the tractor or machine controls from any position other than from the driving seat, especially whilst hitching or unhitching the machine.*
- ▲ *Never carry out maintenance of a machine or a tractor whilst the engine is running – the engine should be switched off, the key removed and pocketed.*
- ▲ *Never leave a machine unattended in a raised position – it should be lowered to the ground in a safe position on a level firm site.*
- ▲ *Never leave a tractor with the key in or the engine running.*
- ▲ *Never carry out maintenance on any part or component of a machine that is raised unless that part or component has been properly substantially braced or supported.*
- ▲ *Never attempt to detect a hydraulic leak with your hand – use a piece of cardboard.*
- ▲ *Never allow children near to, or play on, a tractor or machine under any circumstances.*

ADDITIONAL SAFETY ADVICE

Training

Operators need to be competent and fully capable of operating this machine in a safe and efficient way prior to attempting to use it in any public place. We advise therefore that the prospective operator make use of relevant training courses available such as those run by the Agricultural Training Board, Agricultural Colleges, Dealers and McConnel.

Working in Public Places

When working in public places such as roadsides, consideration should be paid to others in the vicinity. Stop the machine immediately when pedestrians, cyclists and horse riders etc. pass. Restart only when they are at a distance that causes no risk to their safety.

Warning Signs

It is advisable that any working area be covered by suitable warning signs and statutory in public places. Signs should be highly visible and well placed in order to give clear advanced warning of the hazard. Contact the Department of Transport or your Local Highways Authority to obtain detailed information on this subject. The latter should be contacted prior to working on the public highway advising them of the time and location of the intended work asking what is required by way of signs and procedure. – *'Non-authorised placement of road signs may create offences under the Highways Act'*.

Suggested Warning Signs Required

'Road works ahead' warning sign with a supplementary **'Hedge cutting'** plate. **'For 1 mile'** or appropriate shorter distance may be added to the plate.

'Road narrows' warning signs with supplementary **'Single file traffic'** plate.

White on blue **'Keep right'** (*) arrow sign on rear of machine.

** Note – this applies to UK Market machines where traffic passes to the right of a machine working in the same direction as the traffic flow. The direction, use and colour of the arrow sign will depend on the country of use and the Local Highway Authorities regulations in the locality.*

Use of Warning Signs

- ▲ On two-way roads one set of signs is needed facing traffic in each direction.
- ▲ Work should be within 1 mile of the signs.
- ▲ Work only when visibility is good and at times of low risk e.g.: NOT during 'rush-hour'.
- ▲ Vehicles should have an amber-flashing beacon.
- ▲ Ideally, vehicles should be conspicuously coloured.
- ▲ Debris should be removed from the road and path as soon as practicable, and at regular intervals, wearing high visibility clothing and before removing the hazard warning signs.
- ▲ Collect all road signs promptly when the job is completed.

Although the information stated here covers a wide range of safety subjects it is impossible to predict every eventuality that can occur under differing circumstances whilst operating this machine. No advice given here can replace 'good common sense' and 'total awareness' at all times, but will go a long way towards the safe use of your McConnel machine.

FITTING - Tractor requirements

Minimum tractor weights - including ballast weight if necessary:

All models – 4500kg.

Minimum HP requirements:

All models – 75HP

Linkage:

Category 2 – *for mounting of the rear oil tank.*

PTO shaft:

Tractor must be equipped with a live drive PTO to enable forward motion to be stopped while the flailhead continues to operate.

Check Chains/Stabilizers:

Check chains or stabilizers must be fitted and tightened.

GENERAL VEHICLE/TRACTOR PREPARATION

We recommend vehicles are fitted with cabs using safety glass windows and protective guarding when used with our machines.

Fit Operator Guard (part no. 73 13 324) using the hooks provided. Shape mesh to cover all vulnerable areas.

Remember the driver must be looking through mesh and/or polycarbonate glazing when viewing the flail head in any working

position - unless the vehicle/ cab manufacturer can demonstrate that the penetration resistance is equivalent to, or higher than, that provided by mesh/polycarbonate glazing. If the tractor has a roll bar only, a frame must be made to carry both mesh and polycarbonate glazing. The operator should also use personal protective equipment to reduce the risk of serious injury such as; eye protection (mesh visor to EN1731 or safety glasses to EN166), hearing protection to EN352, safety helmet to EN297, gloves, filter mask and high visibility clothing.

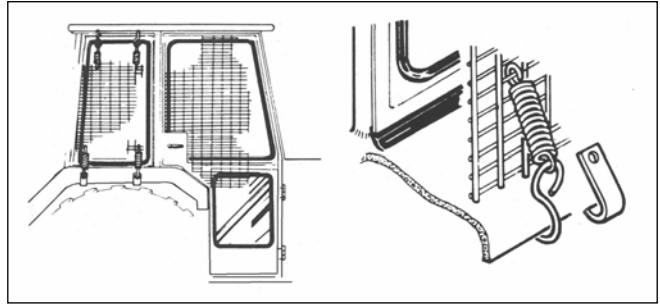

Vehicle Ballast: It is imperative when attaching 'third-party' equipment to a tractor that the maximum possible stability of the machine and tractor combination is achieved – this can be accomplished by the utilisation of 'ballast' in order to counter-balance the additional equipment added.

Front weights may be required to place 15% of total outfit weight on the front axle for stable transport on the road and to reduce 'crabbing' due to the drag of the cutting unit when working on the ground.

Rear weights may be required to maintain a reasonable amount of rear axle load on the opposite wheel from the arms when in work; for normal off-ground work i.e. hedge cutting this should be 20% of rear axle weight or more for adequate control, and for ground work i.e. verge mowing with experienced operators, this can be reduced to 10%.

All factors must be addressed in order to match the type and nature of the equipment added to the circumstances under which it will be used – in the instance of Power Arm Hedgecutters it must be remembered that the machines centre of gravity during work will be constantly moving and will differ from that during transport mode, therefore balance becomes critical.

Factors that effect stability:

- *Centre of gravity of the tractor/machine combination.*
- *Geometric conditions, e.g. position of the cutting head and ballast.*
- *Weight, track width and wheelbase of the tractor.*
- *Acceleration, braking, turning and the relative position of the cutting head during these operations.*
- *Ground conditions, e.g. slope, grip, load capability of the soil/surface.*
- *Rigidity of implement mounting.*

Suggestions to increase stability:

- *Increasing rear wheel track; a tractor with a wider wheel track is more stable.*
- *Ballasting the wheel; it is preferable to use external weights but liquid can be added to around 75% of the tyre volume – water with anti-freeze or the heavier Calcium Chloride alternative can be used.*
- *Addition of weights – care should be taken in selecting the location of the weights to ensure they are added to a position that offers the greatest advantage.*
- *Front axle locking; a ram can be used to 'lock' the front axle in work only – locking the axle moves the 'balance line' and can be used to transfer weight to the front axle from the rear (check with tractor manufacturer).*

The advice above is offered as a guide for stability only and is not a guide to tractor strength - it is therefore recommended that you consult your tractor manufacturer or local dealer to obtain specific advice on this subject, additionally advice should be sought from a tyre specialist with regard to tyre pressures and ratings suitable for the type and nature of the machine you intend to fit.

HYDRAULIC OIL

Hydraulic Oil Reservoir

Fill the tank with oil selected from the chart below or a good quality equivalent to a point where the level is between the minimum and maximum marks on the tank gauge. When the machine is initially run the level will drop as the oil is drawn into the circuit - *top back up as required to the correct level on the gauge.*

Always use clean receptacles when handling and transferring oil to avoid moisture or dirt contamination that can damage components and/or reduce machine performance.

NOTE: Refer to the maintenance section for further information on the subject of hydraulic oil and system filtration.

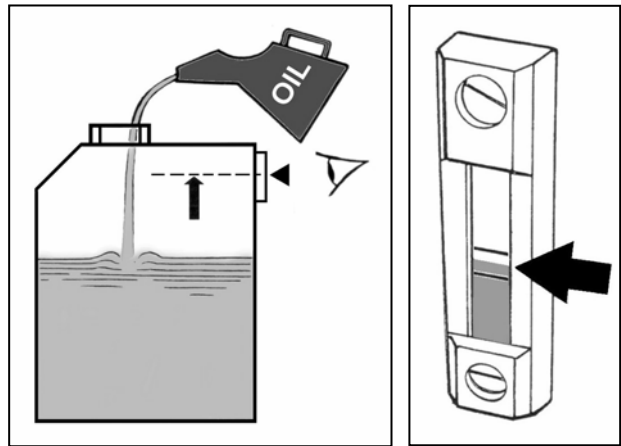

Reservoir Capacity

The oil tank capacity of the machine is approximately **227 Litres**.

Recommended Hydraulic Oils

For initial filling of the oil reservoir, periodic oil changes and replenishment purposes the following hydraulic oils, or a good quality equivalent are recommended:

NOTE: Only use oils that are ISO 18/13 or cleaner.

Manufacturer	Cold or Temperate Climate	Hot Climate
BP	Bartran 46 Energol HLP-HM 46	Bartran 68 Energol HLP-HM 68
CASTROL	Hyspin AWH-M 46	Hyspin AWH-M 68
COMMA	Hydraulic Oil LIC 15	Hydraulic Oil LIC 20
ELF	Hydrelf HV 46 Hydrelf XV 46	Hydrelf HV 68
ESSO	Univis N 46	Univis N 68
FUCHS (UK/Non UK markets*)	Renolin 46 Renolin HVZ 46 Renolin CL46/B15* Renolin AF46/ZAF46B*	Renolin 68 Renolin HVZ 68 Renolin CL68/B20* Renolin AF68/ZAF68B*
GREENWAY	Excelpower HY 68	Excelpower HY 68
MILLERS	Millmax 46 Millmax HV 46	Millmax 68 Millmax HV 68
MORRIS	Liquimatic 5 Liquimatic HV 46 Triad 46	Liquimatic 6 Liquimatic HV 68 Triad 68
SHELL	Tellus 46 Tellus T46	Tellus 68 Tellus T68
TEXACO	Rando HD 46 Rando HDZ 46	Rando HD 68 Rando HDZ 68
TOTAL	Equivis ZS 46	Equivis ZS 68

OPERATING INSTRUCTIONS

Delivery

In most cases the tractor will be delivered with the Hedgemaster factory fitted. If this is not the case, refer to the relevant section on fitting.

Before using this machine for the first time, **remove the transport locking bar**. It is a good idea to start the tractor and operate the Hedger's in-cab controls for five or ten minutes, in a clear open area, just to familiarise yourself with how the machine responds. *(Refer to the relevant controls section for further information)*. You should be able to position the cutting head directly where you want it without looking at the controls. When you can do this you are ready to start work.

The machine is started and stopped by means of the tractor PTO. The PTO should be operated at 540 rpm MAXIMUM. Do not over-rev.

Run rotor up to speed before starting to cut.

Select a low gear (L1 or L2), set cutting head to top off hedge at required height and start to cut, keep forward speed slow to start off with and allow yourself enough cutting time to operate the controls and adjust the position of the cutting head.

Transportation

When travelling down the road, the cutting head should be carried with the flails facing towards the tractor. The first arm should be vertical and the second and third rams should be carefully closed until the skid bears against the ram guard plate on the first arm and the roller drops into the vee-notch, in the footstep. The second ram may have to be extended a small amount until the cutting head skid is just below the footstep to provide adequate ground clearance under the motor guard, but do not jam the skid against the step. The breakaway ram may have to be operated to pull the cutting head back into this position. Fit the transit bar.

NOTE: When preparing to work, ensure the transportation locking bar is removed, before attempting to operate the machine.

Cutting Head Front Guard

The guard is secured by 4 bolts which locate in the notched slots, to change the guard position, loosen the bolts, slide the guard forward out of the notch, move to required position and relocate in notch, retighten bolts.

When cutting heavy growth, the guard should be in the raised position. For verge mowing or cutting tight growth, the guard should be in the lowered position.

Broken Flails

If a flail gets broken or damaged, the cutting head will start to vibrate. Stop the machine immediately and replace the flail. Under no circumstances should the hedger be operated with broken or missing flails.

Demounting

Always demount the machine on firm level ground; demounting is carried out using the machines hydraulic system.

With the hedger arms in the transport position, un-hitch the oil tank and park the tractor so that the oil tank is alongside and central to the back wheel. **Ensure that both taps for hydracushion are turned off.**

Reconnect the pressure and return hoses to the tractor using the extension hoses and connect up the control cable through the left side door or cab window, to allow enough length for the demounting procedure.

Fit the parking legs using the bolts securing the front guard.

Undo the bolts securing socket to underframe, lower head squarely onto the ground close to the tractor, power the socket and arms off the underframe using the cutting head ram.

Fully close 1st ram and fold arms up tight.

Remove hoses from tractor and plug/cap ends. Clean and plug/cap motor hoses and stow away neatly.

Mounting

Mounting the machine is a reversal of above.

Ensure the socket has seated squarely on the underframe plugs before re-fitting the securing bolts. Check bolts after first hours of operation for security.

WARNING! Keep Clear of Overhead Power Lines.

Pre-Operation Checks

Check the following before commencing work:

- Hydraulic oil level.
- Transit bar has been removed.
- Cutting flails for damaged or loose bolts.
- Ensure there is no wrappage around the rotor or bearings, and grub screws are secure.
- All guards are fitted correctly.
- Front flap is fitted correctly and the adjustment bolts are secure.
- All mounting bolts are secure.
- Ensure tractor cab windows are fitted with safety glass and mesh guards.
- Inspect all hedges to be cut, for metal posts and particularly barbed wire.
- Ensure all wire is removed from the hedge before work commences.
- Do not rev the engine and engage the PTO sharply when starting the rotor.
- Do not operate the machine with the breakaway in the breakback position.

Safe Working Guidelines

- DO NOT operate the machine without guards fitted.
- DO NOT operate the machine with broken or missing flails.
- DO NOT operate the machine without safety glass and wire mesh fitted to the tractor windows.
- DO NOT alter any of the service line relief valves pressure settings.
- DO NOT make any adjustments to the hydraulic system without first sitting the cutting head firmly on the ground; disengaging PTO and turning off the tractor engine.
- DO NOT exceed the 540RPM PTO speed.
- STOP AT ONCE if it is suspected that wire may be wrapped around the rotor shaft. STOP THE PTO AND STOP THE TRACTOR ENGINE!
Important Note: The front flap acts to stop most material being discharged from the front of the cutting head. Always keep the guard adjusted as low as possible. Wire with a flapping end can be dangerous; not only to the operator, but possibly to passers by. ALL wire must be removed before re-starting work.
- Operators are advised to wear ear protectors.
- Operators must ensure that any persons in the vicinity of the machine are aware of the operator's intentions, and are away from the hazardous zones.
- DANGER - Always keep a sharp look out for overhead obstacles, especially POWER LINES!!
- Observe the verge or hedge immediately in front of the cutting head so you and the machine have time to react.
- After finishing work ensure the transit bar is fitted before proceeding down the road.

FITTING INSTRUCTIONS

Notes on Fitting

The security and approval of a safety cab depends upon it being attached to the tractor as originally designed by the manufacturer except where specific modifications have been agreed and accepted. When fitting Econ equipment to tractors fitted with safety cabs only those bolts identified in the fitting instructions should be utilised, no other bolts should be touched. In all circumstances where it is not possible to obtain adequate bolt to nut engagement you must consult the tractor manufacturers before using the equipment.

Extra care should be taken in positioning the pressure, and particularly the return hoses, to the hydraulic motor to eliminate any restrictions, specifically with the arms in the folded position. Restriction of the return line will cause the motor seal to leak. All machines are test run to full working pressures and fully checked before leaving the factory. No warranty claim can be considered for leaking motor seals after initial fitting to the tractor.

Mounting bolts MUST be checked twice daily until the machine is fully bedded in.

Once the machine has been fitted refer to the relevant section on lubrication and grease all round.

Stability and Counterweight

As the stability is a major safety factor, considerable care has to be taken.

The HM3E mower would have approximately 500lbs (*225 kilos*) of weight added, either as water ballast or the Econ 'plug-in' weight assembly; which ever was the better option for the particular mower/tractor combination.

Note: Even if the Econ 'Package Deal' states that the weight assembly would be used, sometimes it is better to use tractor wheel weights and/or water ballast which ever is best would be fitted.

Widening the front wheels does not assist stability.

As a general guide to the correct amount of counter weight, the cutting head should be extended to maximum reach on level ground, and a weight equal to 170lbs (*75kg*) placed on the cutting head. Provided the opposite side rear wheel is firmly in contact with the ground the machine will be stable to operate on reasonably level conditions.

Fitting HM3E Using Econ Plain Bracket Kit

The kit has three brackets which attach to the tractor at the following three points.

1. Left side front casting or chassis frame.
2. Right side mid-mounting (usually on the side of the clutch housing or the chassis frame).
3. Left side rear axle.

The brackets supplied in this kit have to be drilled and cut to fit the tractor being used. The universal underframe is attached to these brackets and can be removed quickly after removing the 4 x M12 bolts and 1 pin.

The distance between the front of the tractor cab and the back of the front tyre should not be less than 400mm to allow the cutting head and arm assembly to be fitted.

1. Light Extension Brackets (LH & RH)
2. Pin
R Clip
3. Mid Offside Bracket
4. Packer
5. Rear Axle Bracket
6. Rear Bracket (Lower)
7. Underframe
8. Clamp Plate Rear
Bolt
Nyloc Nut
9. Clamp Plate Mid
Bolt
Nut
10. Front Mounting
Bolt
11. Front Bracket

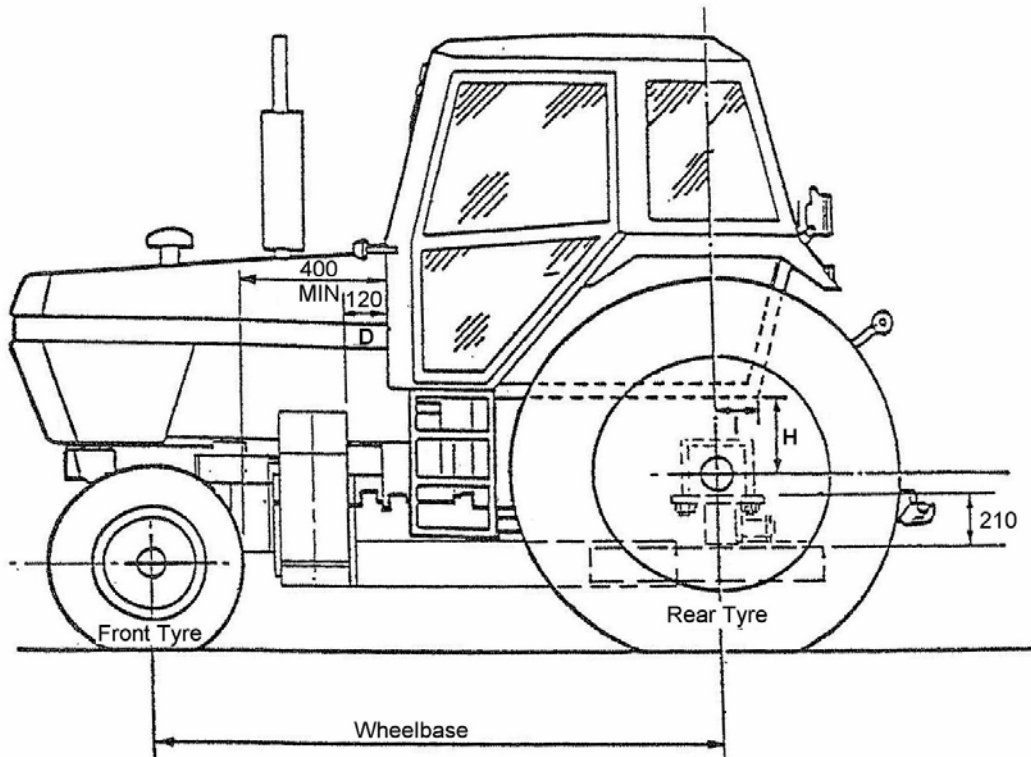
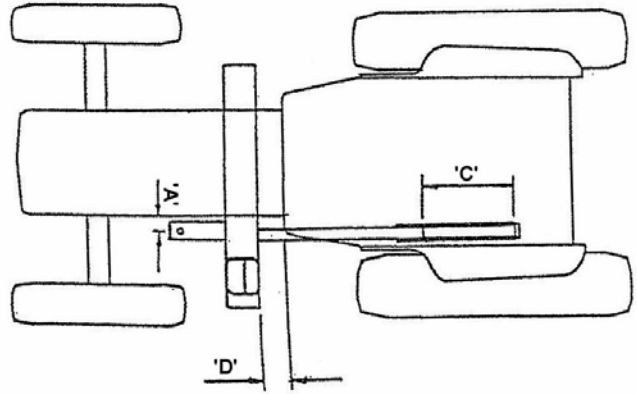
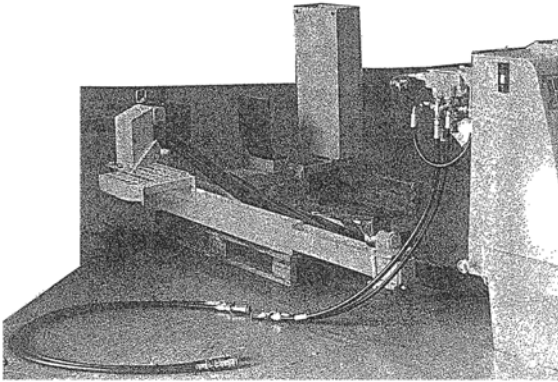
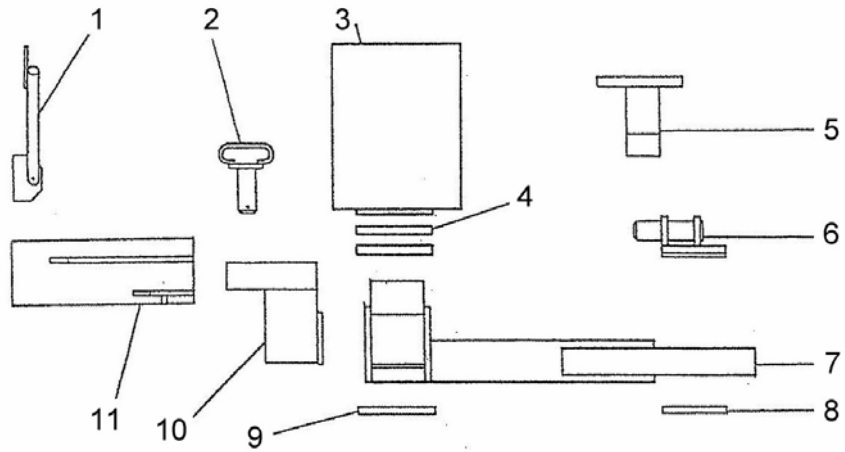

Positioning the Underframe

When reading this section, refer to the illustrations on the previous page as required.

Position the tractor on level ground.

It may be necessary to remove the following parts: left side cab steps and 3-point linkage check chain.

Slide the main frame under the tractor from left hand side between the wheels.

Raise frame close to the underside of tractor leaving 210mm between the bottom of the axle and top of the underframe. On four wheel drive tractors ensure it is clear of the prop shaft etc. Set underframe to 120mm from upright box section to foremost part of cab, (Dimension 'D'). Prop the frame; ensure it is true using a spirit level.

Refer to illustration for all item numbers.

Fit front mounting (Item 10) to front of underframe (item 7) use 4 x M16 bolts in the most suitable of the alternative positions, high position - tractors with under-slung fuel tank. Set underframe so that centre of 40mm hole in front mounting is 63mm from side of tractor front mounting face, (Dimension 'A').

Ensure the tyre does not catch the underframe when the wheel is articulated. If the wheel interferes with the underframe move the underframe closer to cab until wheel turns freely (minimum dimension 'D' is 70mm).

A minimum of 3 x 16mm bolts are required for attaching each mounting bracket.

Rear Mounting Bracket

The rear mounting bracket (item 5) will need drilling to suit existing mounting points under the axle or alternatively use larger bolts which clamp around the axle.

If the mounting holes are offset to one side of the mounting boss, the bracket will need gusseting to maintain sufficient strength.

Remove excess material from the plate to clear lower link bracket etc. and fit bracket under axle.

The lower part of the rear bracket (item 6) is not drilled to allow it to be offset if required to clear the 3-point linkage. It should be drilled to match the 3 x 16.5mm holes in the clamp plate (item 8); also a piece of plate is supplied for welding to the bottom of the bracket to locate between the side plates of the underframe.

Slide the lower part of rear bracket into hole in upper part from the rear and secure to underframe with clamp plate and 3 x M16 x 150mm bolts.

Front Mounting Bracket - Left Side (Item 11)

This should be drilled to suit the mounting holes on the left side front casting or chassis frame. It is helpful to make a cardboard template to mark out the holes and shape of the plate. Cut off excess material to clear side panels, axle and steering ram.

Bolt on tractor and connect to underframe with 40mm pin (item 2).

Mid Mounting Bracket - Right Side (item 3)

The bracket is to be clamped to the underframe using 4 x M12 bolts and a clamp plate (item 9) underneath. Also packers (item 4) are supplied to adjust the bracket to a suitable height.

The bracket should be drilled and cut to suit mounting holes usually on the side of the bell housing. On some tractors it may require removal of a spacer on the front cab mounting and inserting the bracket in its place. Spacers may be required between the casting and the bracket.

Hydraulic Tank and Drive Assembly

Using the tractor 3-point linkage, pick up the whole assembly and connect the free end of both chains to the upper link pin on the tractor, cross the chains. Lower the unit until all the weight is taken by the chains.

Connect hydraulic hoses and PTO drive shaft – *refer to following page for information regarding PTO installation.*

Control Box Mounting

The rectangular bracket supplied; together with the telescopic floor mounted pedestal should be bolted in a suitable position to allow the control box to be mounted where it is convenient for easy operation. The control box requires a 12 volt DC 10 Amp continuous supply to the two pin plug and socket supplied. It should be connected positive to the red cable and negative (or earth) to the black cable.

Side Lights

It may be necessary to relocate the side lights on extension brackets if obscured by the mower arm.

PTO DRIVESHAFT INSTALLATION

The PTO driveshaft attaches between the tractor and the machine gearbox to transfer the power required to run and operate the machine – it is important to achieve the correct shaft length to avoid risk of it ‘bottoming out’ when raising or lowering the machine.

The procedure for measuring and cutting the shaft is as follows:

Measuring the PTO Shaft

With the machine attached to the tractor in the working position measure the horizontal distance ‘A’ from the tractor’s PTO to the input shaft on the machines gearbox and subtract 75mm (3”) – *this figure is the required shaft length.*

Place the fully closed PTO shaft on the ground and measure its overall length, if the shaft is shorter than the required length you can use it without the need to shorten - *providing it allows for a minimum 150mm (6”) overlap when fitted.*

If the shaft is longer subtract the required shaft length plus an additional 75mm (3”) - *the resulting figure is the excess length that will need to be removed from each half of the shaft.*

Cutting the PTO Shaft

Separate the two halves and using the measurement obtained above shorten both the plastic guarding and the inner steel profile tubes of each shaft by this same amount. De-burr the cut tubes with a file to remove rough or sharp edges and thoroughly clean to remove swarf before greasing, assembling and fitting the shaft.

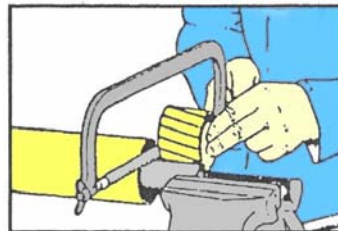
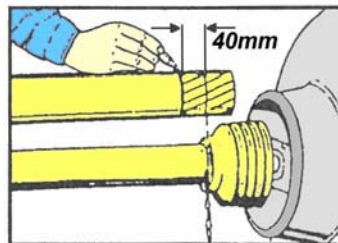
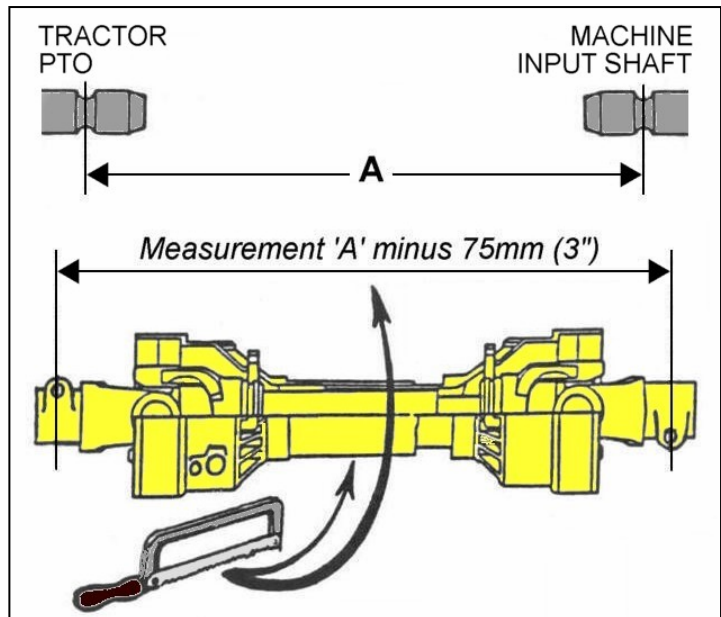

NOTE: For subsequent use with different tractors the shaft should be measured again to check suitability – *there must be a minimum shaft overlap of 150mm (6”).*

Maintenance

To increase the working life of the PTO shaft it should be periodically checked, cleaned and lubricated – *refer to the PTO maintenance section for further details on this subject.*

CONTROLS

Arm Movements

It is advisable to familiarise yourself with the machine controls fully before attempting to use them with the tractor and machine running. When and only when, you are sure which control moves which arm, should you start the engine. Practices operating the machine with the tractor stationary in a clear safe area until you are confident that you can operate the machine safely.

Only after having operated the machine for some considerable time so that you know which lever to pull (or push) without having to look at the control marker, can you start to move off and operate the arms on the move as follows.

Safety First

1. Ensure no person is standing near the cutting head.
2. Ensure cutting head is clear of all obstructions.
3. The tractor hydraulics valve should be positioned such that the lift linkage does not raise or lower.
4. The cutting head rotor commences to rotate when the Start - Rotor switch/button is engaged with the PTO running. The valve has a soft start facility.
5. When moving forward, always watch the verge or hedge approximately 3 - 4 feet in advance of the cutting head.
6. After approximately 10 minutes use from new, should any sponginess remain in the hydraulic rams, bleed the air from them by partially unscrewing (NOT removing) the hydraulic connection to, the ram, operate the appropriate valve with the tractor engine at tick-over and reconnect tightly once all air is removed. Check Hedger hydraulic fluid level and top up if necessary.
7. Ensure that the locking Allen screws for the main rotor bearing are kept secure.
Check twice daily - If screws become insecure damage to the motor will occur.

Arm Movements (Hydrafloat)

The degree of 'float' in the arm (and hence the reduction of drag of the head on the ground) is governed by the arm extension or 'reach' and hydraulic cushioning selected by the operator.

Lower the machine to the ground (having started the rotor) at the desired reach. Select 'float' position in the cutting head and operate the first arm control to raise the machine. This will have the effect of pressurising the 1st ram system.

Keep adjusting the 'hydrafloat' as the machine follows the ground (by short quick pumping actions) on the first arm control level, either forwards (lower) to reduce the pressure or backwards (raise) to increase the pressure.

The best degree of 'float' can be felt by the side pull of the machine on the steering. This 'side pull' must be kept to a minimum so that the correct steering and cutting width can be maintained. Do not waste width.

When verge mowing, hydrafloat must be used. Open taps on the spool valve block and 'hydrocushion' accumulator (turn anti-clockwise). The 'hydracushion' causes most of the weight of the arms and cutting head to be carried on the tractor. This ensures that the cutting head follows the ground contours tightly, and does not dig into rises or fail to drop down into depressions.

When hedging, do not use the float position. You will want the cutting head to accurately maintain its set position, ensure both the taps on the valve block and 'hydracushion' accumulator are turned off (clockwise).

The gas accumulator is fitted adjacent to the Hedgemaster control valve block to enable float positions of the arms. The union on top of the accumulator is used to check and refill the unit with Nitrogen gas and should be maintained within 52-55 bar (750-800 *lb.in²*), however, this figure may be increased to a maximum 133 bar (2000 *lb.in²*) if required.

Arm Lowering - Speed Adjustment

Fitted at the opposite side of the valve block to the accumulator, are two control valves. These are used to control the rate in which the 1st and 2nd arms will fall, (not the lifting speed). Normally set at position No 1, the lower valve controls the 1st arm and the upper valve controls the 2nd arm.



Valve Block & Accumulator

OPERATING PRINCIPALS

The mid mounted position of the mower on your tractor gives the operator the best steering response and the most comfortable view of the cutting operation, therefore;

Watch well in front of the cutting head

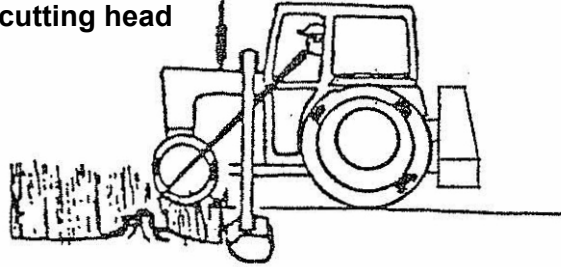

Steer around or lift over obstacles. Remember you and your machine need reaction time.

Steer to a near full cutting head width to achieve maximum acreage covered

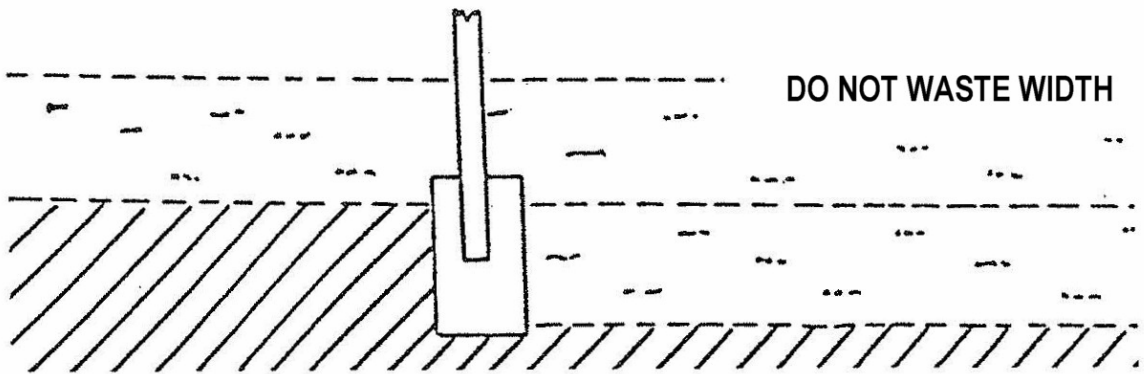

Set controls to achieve level cutting, particularly on bank work

NOT THIS

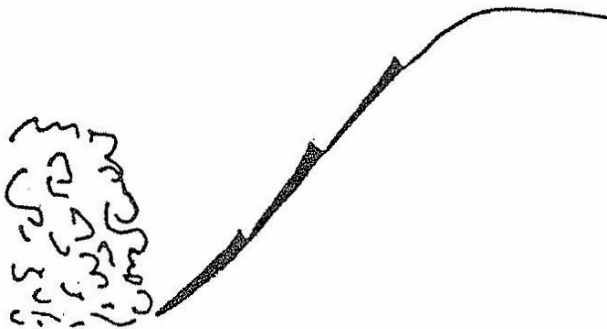

BUT THIS

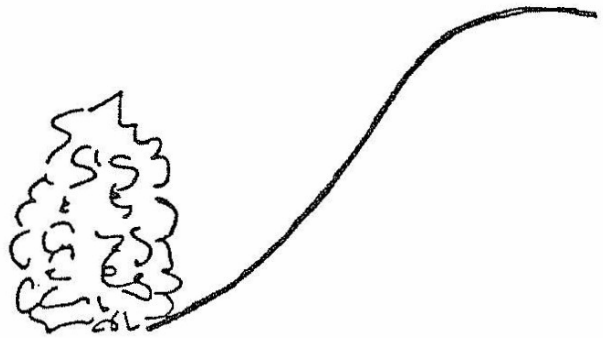

Travel at the right speed to give a clean cut, no 'hairy' pieces stuck up, but at a high enough speed to match the high performance capability of the machine.

ELECTRIC SWITCHBOX CONTROLS

Machines with Electric Switchbox Controls will be supplied with the control unit shown below.



LOCATION & FUNCTION OF CONTROLS

- | | |
|--------------------------------|---------------------------------------|
| 1. 1st Ram (Lift #1) Control | A. Power On/Off (Emergency Stop) |
| 2. 3rd Ram (Reach) Control | B. N/A |
| 3. 4th Ram (Angle) Control | C. Head Float - Angle/Lift (Option) |
| 4. 5th Ram (Breakaway) Control | D. Rotor On/Off (Electric RCV models) |
| 5. 2nd Ram (Lift #2) Control | E. Rotor Direction (if applicable) |

Powering the Controls

Activation of power to the control unit is by operation of switch 'A' as shown below:

Press the switch down for Power ON (LED light on)

Press the switch up for Power OFF (LED light off)

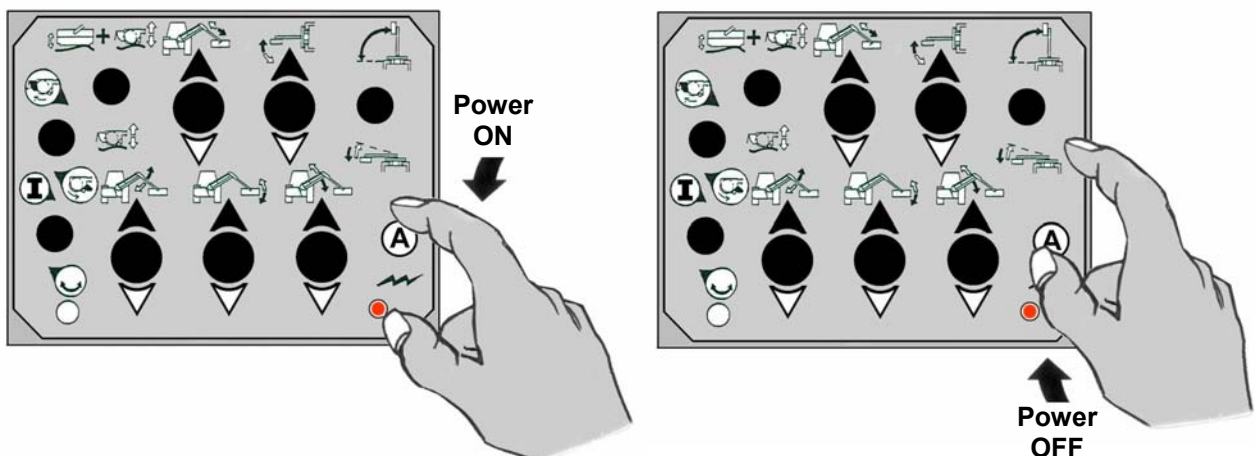

ARM OPERATION (SWITCHBOX CONTROL)

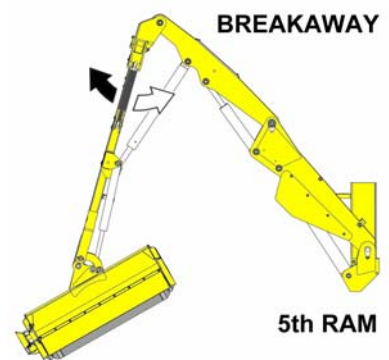
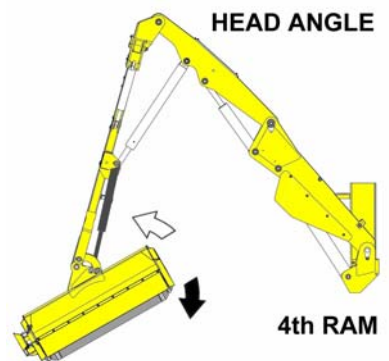
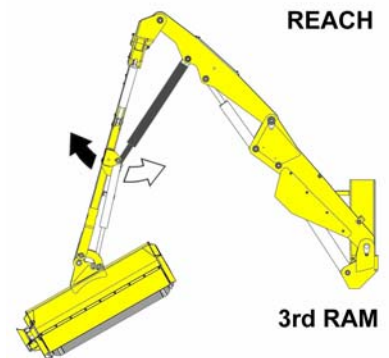
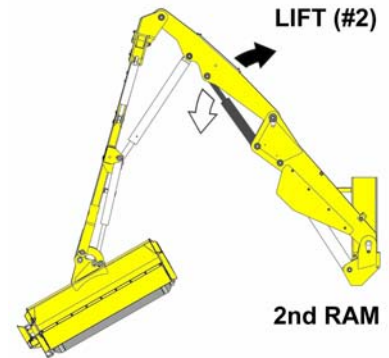
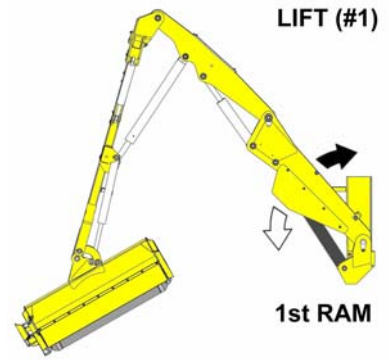
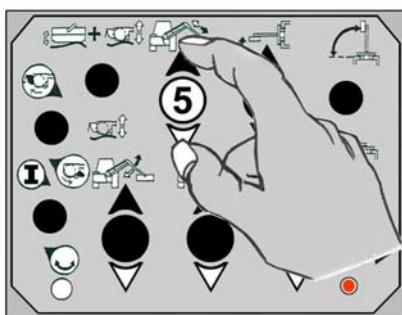
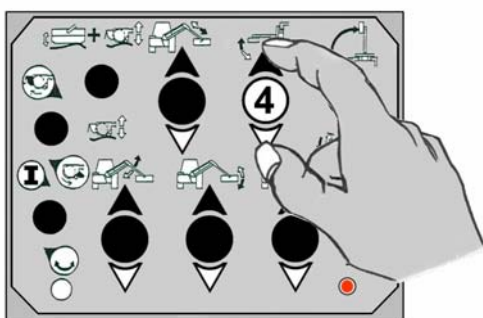
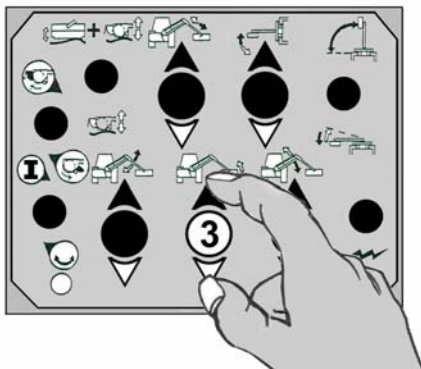
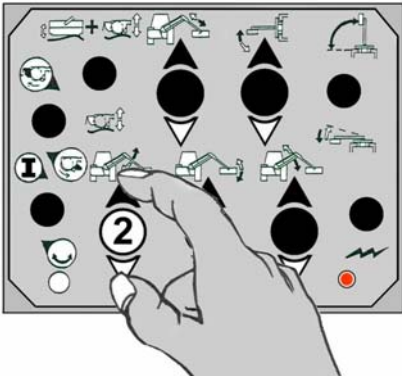
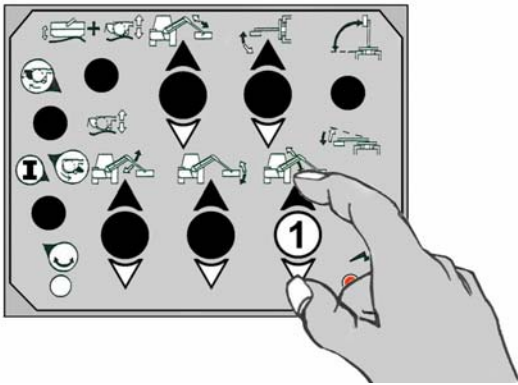

HEAD FLOAT OPERATION (Angle Float standard / Lift Float optional)

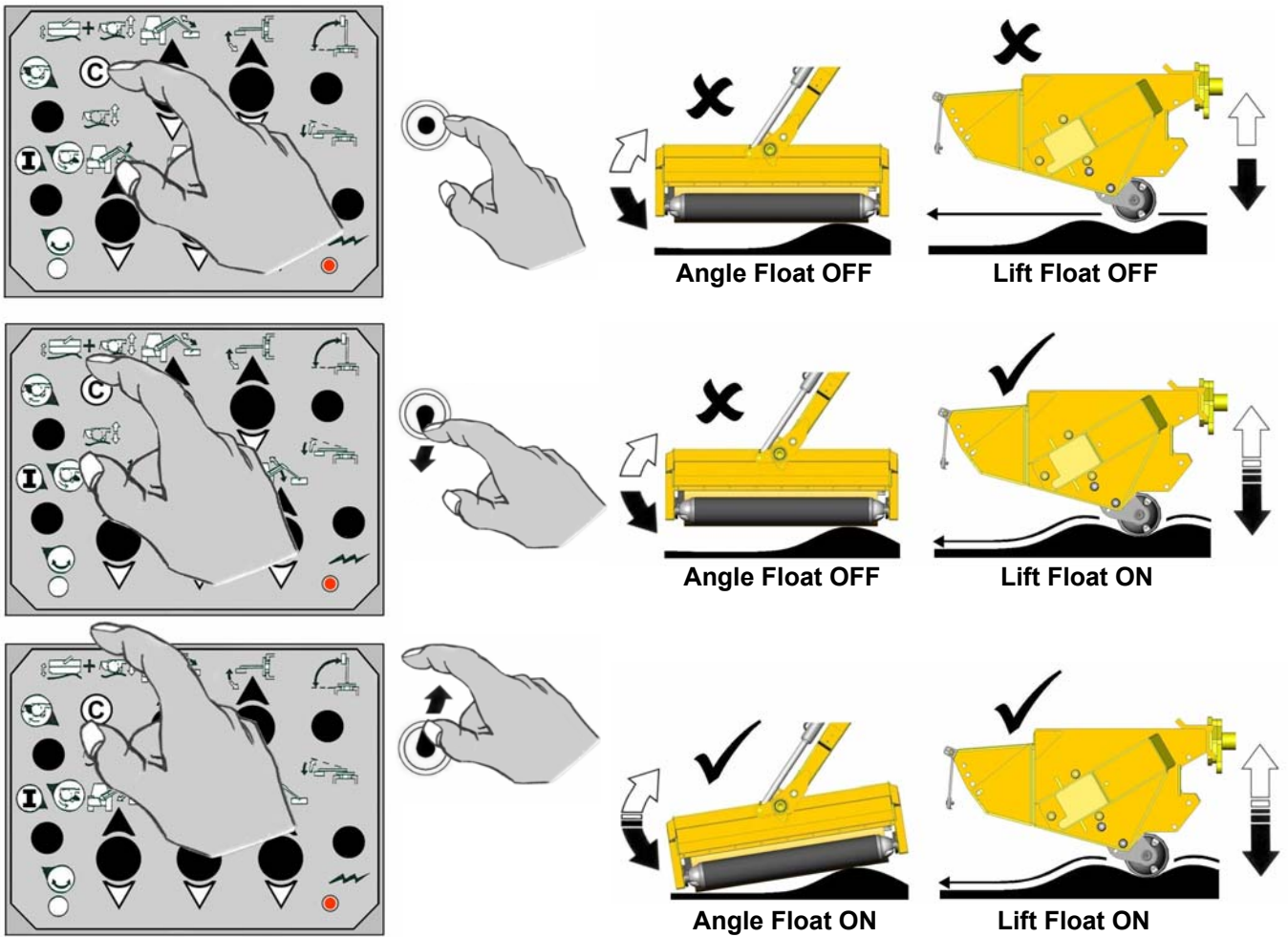

ROTOR OPERATION

Selection of Rotor Cutting Direction (where applicable)

Uphill Cutting

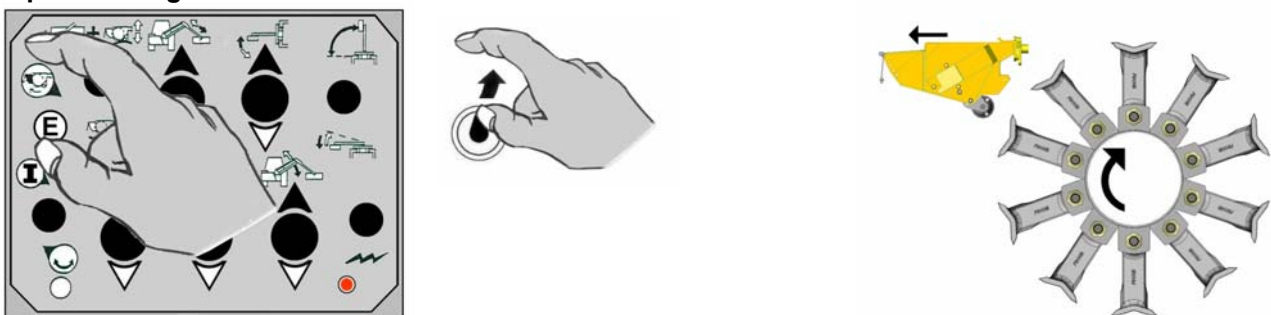

Downhill Cutting



Switching the Rotor On

For safety reasons, to prevent accidental starting of the rotor, the 'Rotor On' switch cannot be activated in a single operation or without first selecting the direction of cut – the procedure for starting the rotor is as follows:

Select the required cutting direction - the Rotor On/Off Switch (D) must then be switched upwards and held in position for a minimum of 8 seconds before switching it into the fully down 'on' position where it will remain until it is switched off. When the switch is moved to the down position the red LED light below the switch will be lit to signify the rotor is on – if the LED does not light the switch was not held in its up position for long enough and the rotor will not have started, repeat the process again holding the switch upwards for a longer period.

Rotor Start

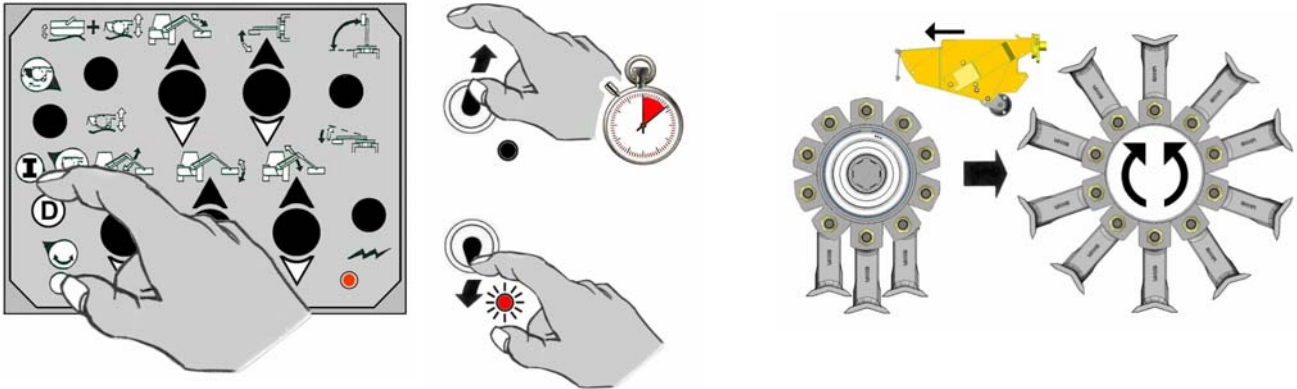

Switching the Rotor Off

Stopping the rotor is performed by switching either the Rotor Power Switch (D) or the Rotor Direction Switch (E) to the central (off) position – the red LED light will go out to signify the rotor has been switched off.



CAUTION: When the rotor is switched off it will continue to 'freewheel' under its own momentum for up to 40 seconds before finally coming to a standstill – do not leave the tractor cab or attempt to approach the flailhead until the rotor has stopped turning completely.

Rotor Stop

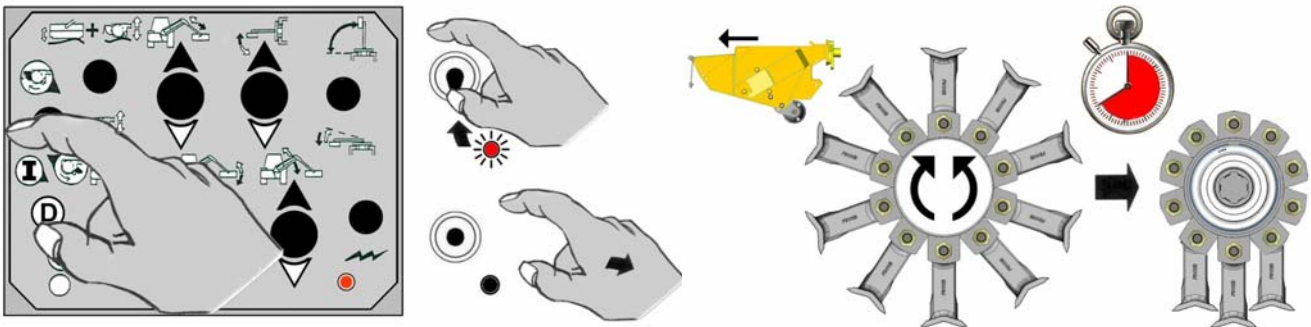

Alternative Rotor Stop

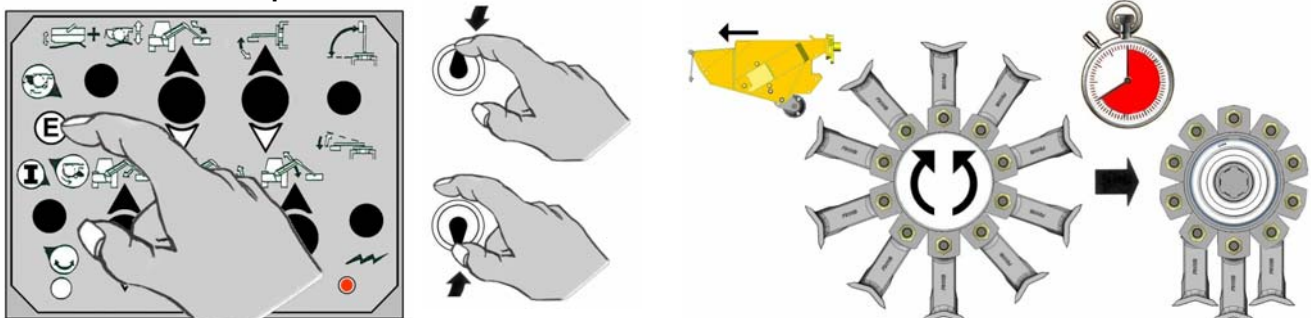

ELECTRIC MONOLEVER CONTROLS

Machines with Electric Monolever Controls will be supplied with the control unit shown below.



LOCATION & FUNCTION OF CONTROLS

- | | |
|--------------------------------|---------------------------------------|
| 6. 1st Ram (Lift #1) Control | F. Power On/Off (Emergency Stop) |
| 7. 3rd Ram (Reach) Control | G. N/A |
| 8. 4th Ram (Angle) Control | H. Head Float - Angle/Lift (Option) |
| 9. 5th Ram (Breakaway) Control | I. Rotor On/Off (Electric RCV models) |
| 10. 2nd Ram (Lift #2) Control | J. Rotor Direction (if applicable) |

Powering the Controls

Activation of power to the control unit is by operation of switch 'A' as shown below:

Rotate the switch clockwise to Power ON (LED light on)

Press the switch to Power OFF or Emergency Stop (LED light off)



ARM OPERATION (MONOLEVER CONTROL)

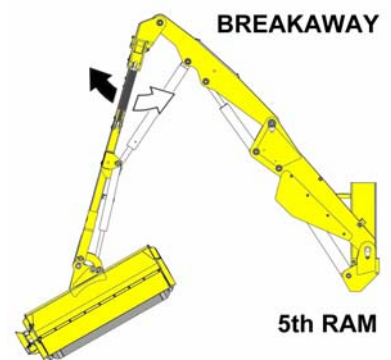
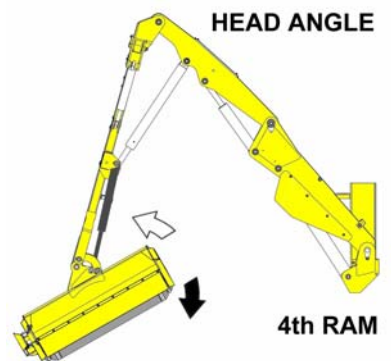
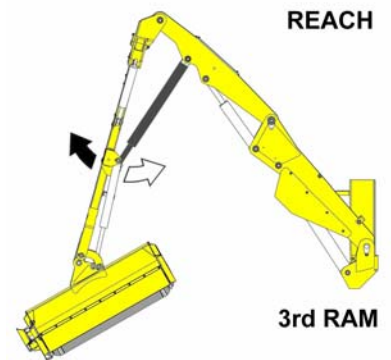
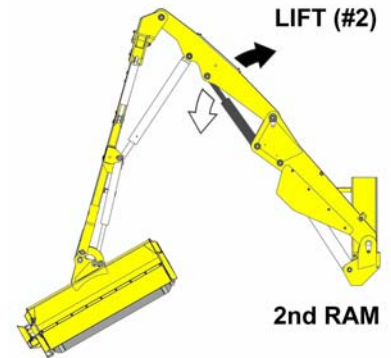
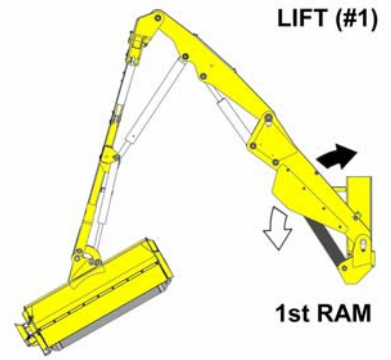

HEAD FLOAT OPERATION (Angle Float standard / Lift Float optional)

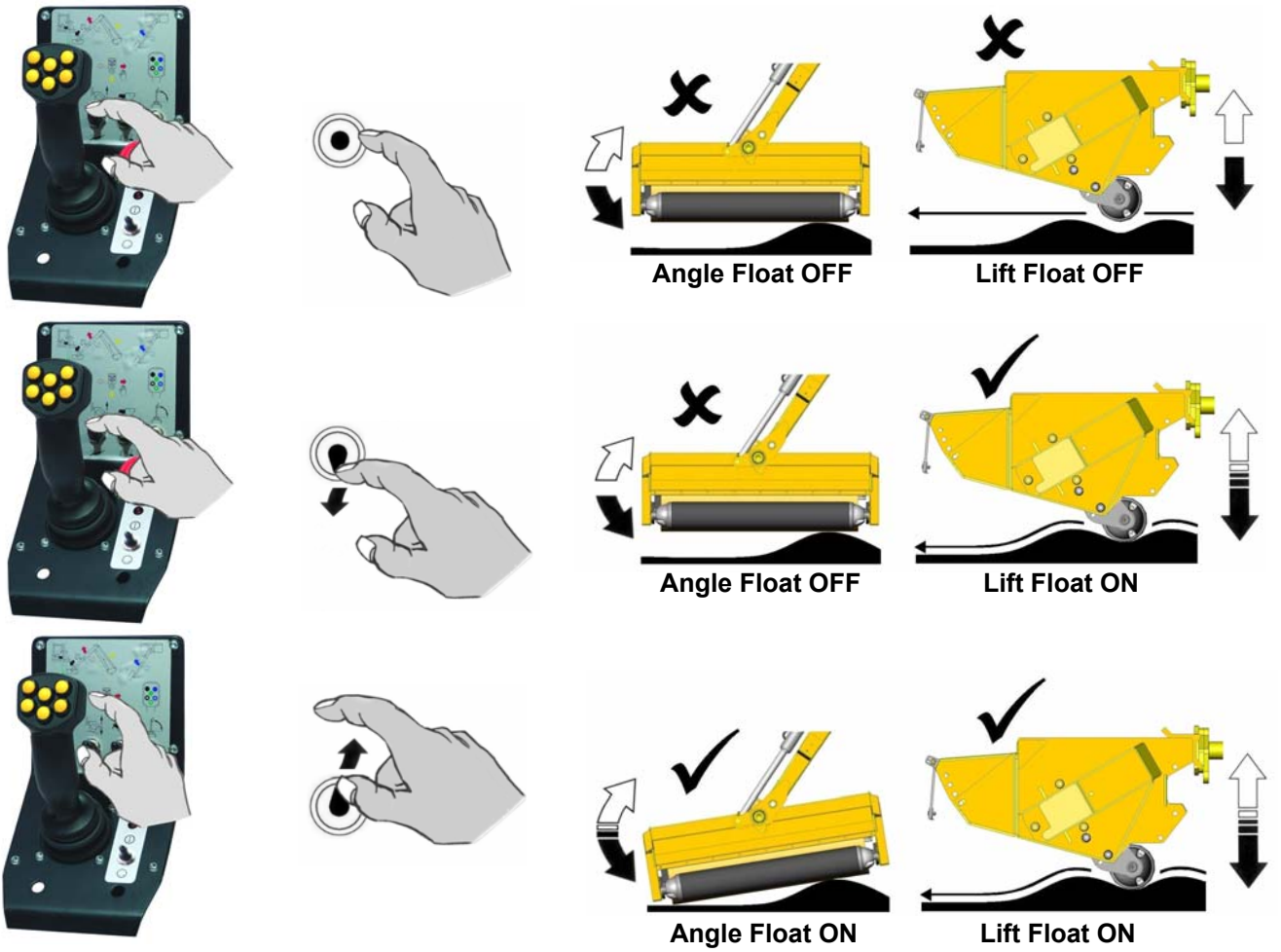

ROTOR OPERATION

Selection of Rotor Cutting Direction (where applicable)

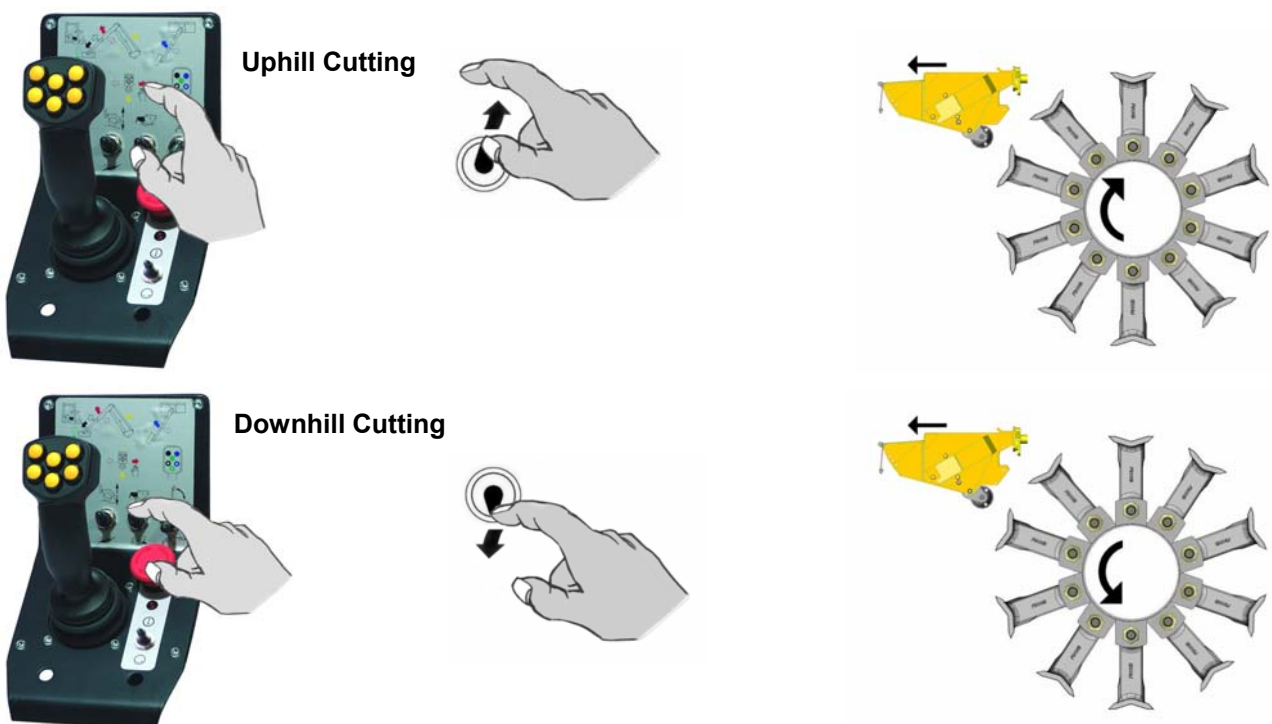

Switching the Rotor On

For safety reasons, to prevent accidental starting of the rotor, the 'Rotor On' switch cannot be activated in a single operation or without first selecting the direction of cut – the procedure for starting the rotor is as follows:

Select the required cutting direction - the Rotor On/Off Switch (D) must then be switched upwards and held in position for a minimum of 8 seconds before switching it into the fully down 'on' position where it will remain until it is switched off. When the switch is moved to the down position the red LED light above the switch will be lit to signify the rotor is on – if the LED does not light the switch was not held in its up position for long enough and the rotor will not have started, repeat the process again holding the switch upwards for a longer period.

Rotor Start

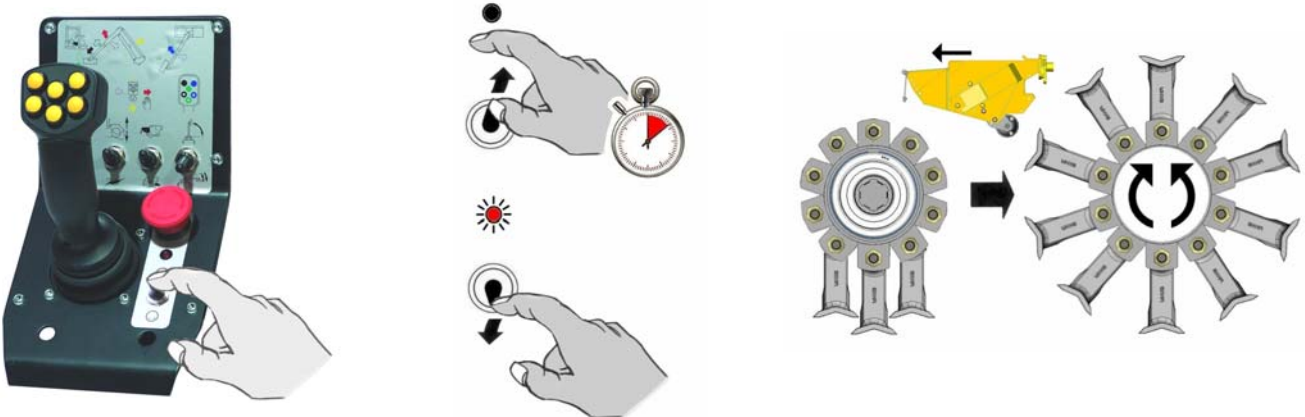

Switching the Rotor Off

Stopping the rotor is performed by switching either the Rotor Power Switch (D) or the Rotor Direction Switch (E) to the central (off) position – the red LED light will go out to signify the rotor has been switched off.



CAUTION: When the rotor is switched off it will continue to 'freewheel' under its own momentum for up to 40 seconds before finally coming to a standstill – do not leave the tractor cab or attempt to approach the flailhead until the rotor has stopped completely.

Rotor Stop

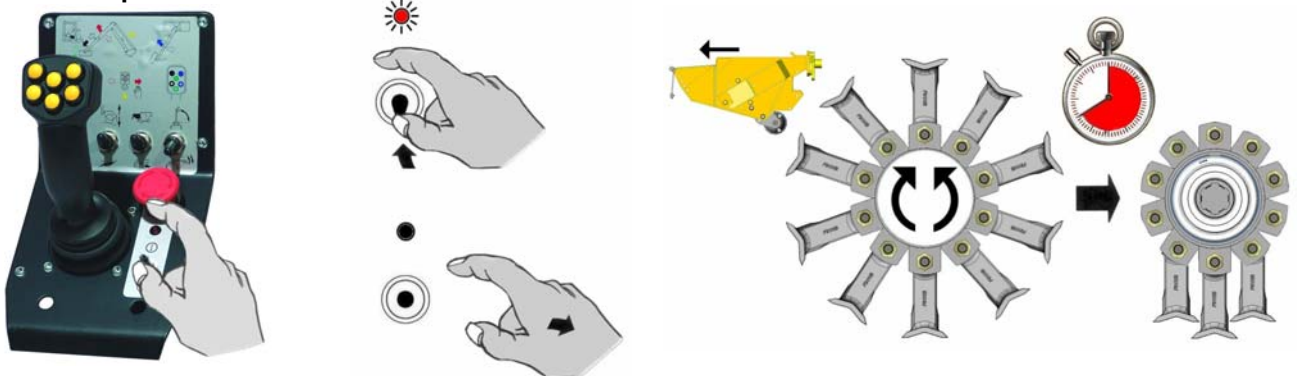

Alternative Rotor Stop

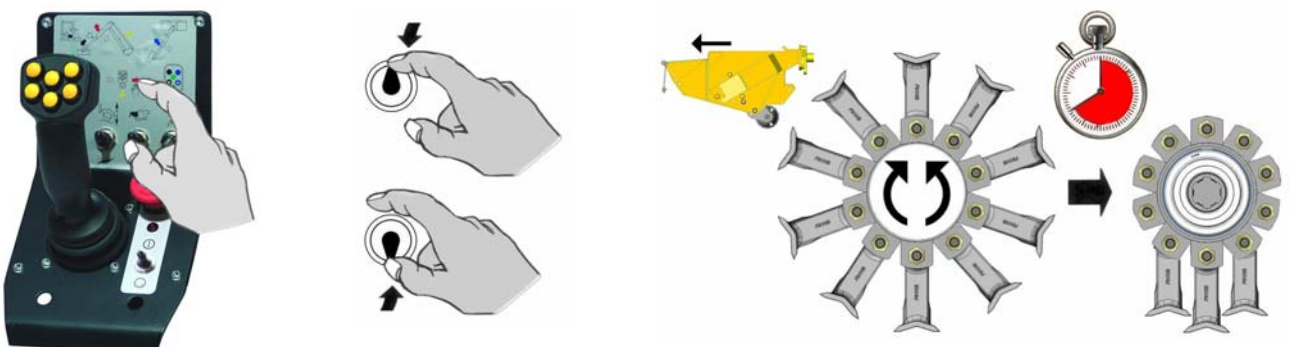

V4 PROPORTIONAL CONTROLS

POWER ON / OFF (Emergency Stop)

Rotate Clockwise to Power On – control unit will emit a single beep and screen will display the selected PTO speed, software version and the McConnell name. Press to Power Off.

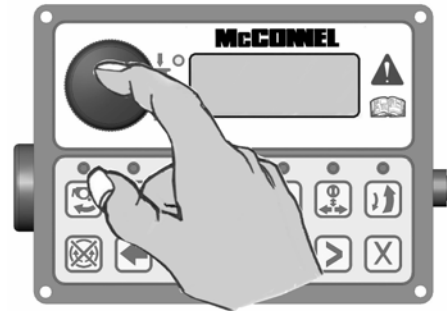

ROTOR START – Uphill Cutting

This button starts the rotor for ‘uphill’ cutting – when the button is pressed the control unit will emit a single beep, the LED light will illuminate and the screen will momentarily display ‘FLAIL START ✓’.

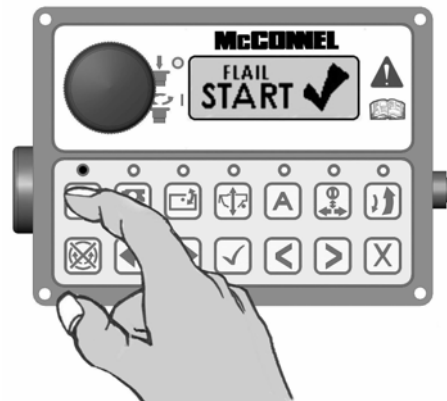

ROTOR START – Downhill Cutting

This button starts the rotor for ‘downhill’ cutting – when the button is pressed the control unit will emit a single beep, the LED light will illuminate and the screen will momentarily display ‘FLAIL START ✓’.

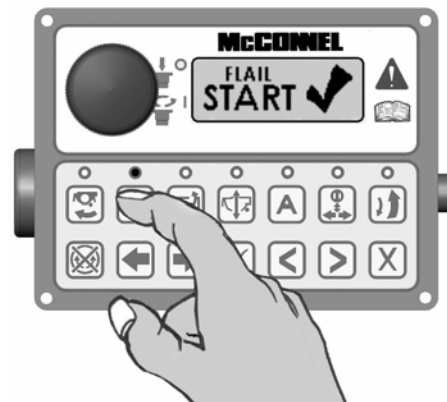

ROTOR STOP

This button stops the rotor – when the button is pressed the control unit will emit a single beep and the screen will momentarily display ‘FLAIL STOP ✓’ – the LED lights above both rotor start buttons will be illuminated for approximately 10 seconds, during this period the rotor start buttons will be disabled to allow sufficient time for the rotor to power down. When the LED lights go out the rotor direction can be changed or the rotor allowed to stop.

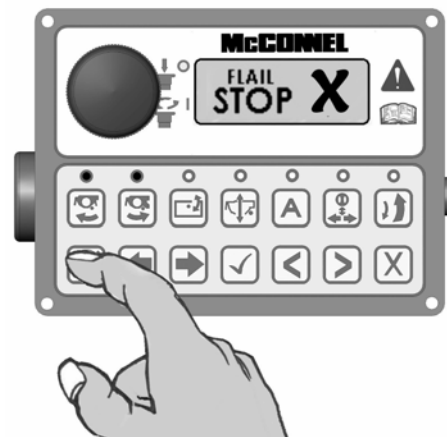

WARNING: The LED lights going out do not indicate that the rotor has stopped rotating, it signifies only that the oil flow to the rotor has ceased sufficient for the direction of rotation to be changed - therefore when stopping a rotor it must be noted that it will continue to freewheel for a considerable length of time after the stop button has been activated, in some case this can be up to 40 seconds.

HEAD ANGLE FLOAT

There are 2 methods available for selection and de-selection of this function; activation via the control unit - refer to #1 below, or activation via the joystick controls - refer to #2 below.

1. Pressing the Head Angle Float button – when activated the control unit will emit a single beep, the LED light will illuminate and the screen will momentarily display 'ANGLE FLOAT ✓' pressing the button again will deselect the function – the control unit will emit a single beep, the LED light will go out and the screen will momentarily display 'ANGLE FLOAT X'.

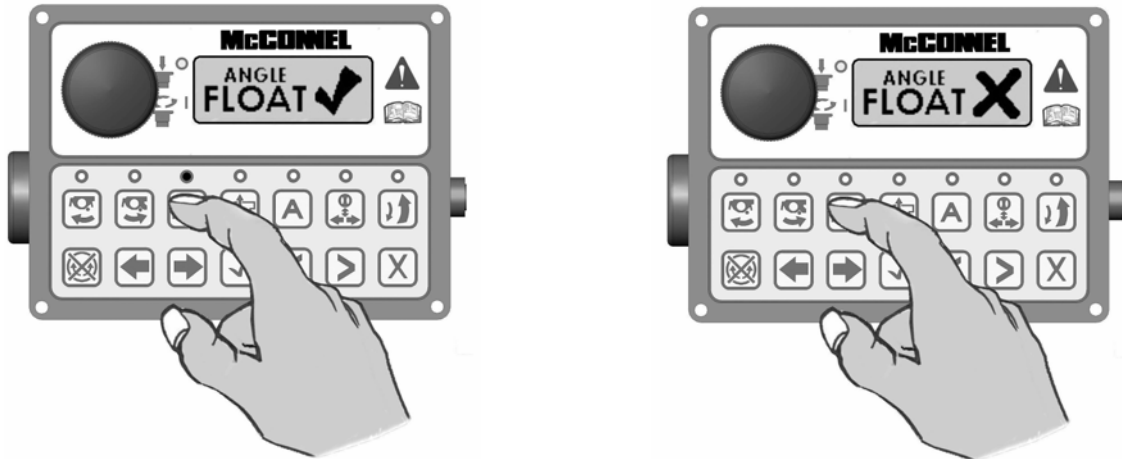

2. Press and hold in the lower frontal button (B1) on the joystick control and roll the left hand thumbwheel (T1) forwards – the control unit will emit a single beep, the LED light will illuminate and the screen will momentarily display 'ANGLE FLOAT ✓'.

To deselect press and hold in the lower frontal button (B1) on the joystick control and roll the left hand thumbwheel (T1) backwards – the control unit will emit a single beep, the LED light will go out and the screen will momentarily display 'ANGLE FLOAT X'.

NOTE: When selecting or deselecting the function, the thumbwheel (T1) should be allowed to return to its centre position before releasing the lower frontal button (B1).

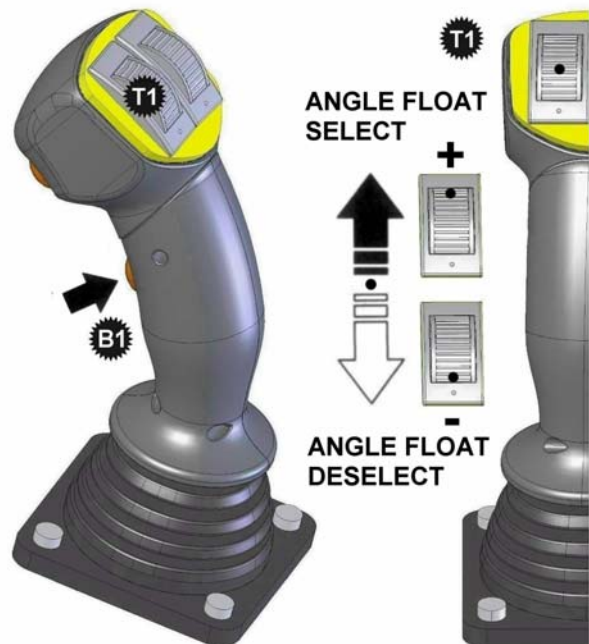

NOTE: By default operation of thumbwheels T1 and T2 in conjunction with button B1 activates Head Angle Float and EDS/Lift Float respectively. These controls can, if required, be swapped over so that the thumbwheels operate the opposing functions – this procedure is performed by accessing the settings menu on the control unit via the screen and menu buttons.

EDS FUNCTION (EDS Models) / LIFT FLOAT (Non EDS Models)

There are 2 methods available for selection and de-selection of this function; activation via the control unit - refer to #1 below, or activation via the joystick controls - refer to #2 below.

1. Pressing the EDS / Lift Float button will activate the relevant function – when activated the control unit will emit a single beep, the LED light will illuminate and the screen will momentarily display 'LIFT FLOAT ✓'. Pressing the button again will deselect the function – the control unit will emit a single beep, the LED light will go out and the screen will momentarily display 'LIFT FLOAT X'.

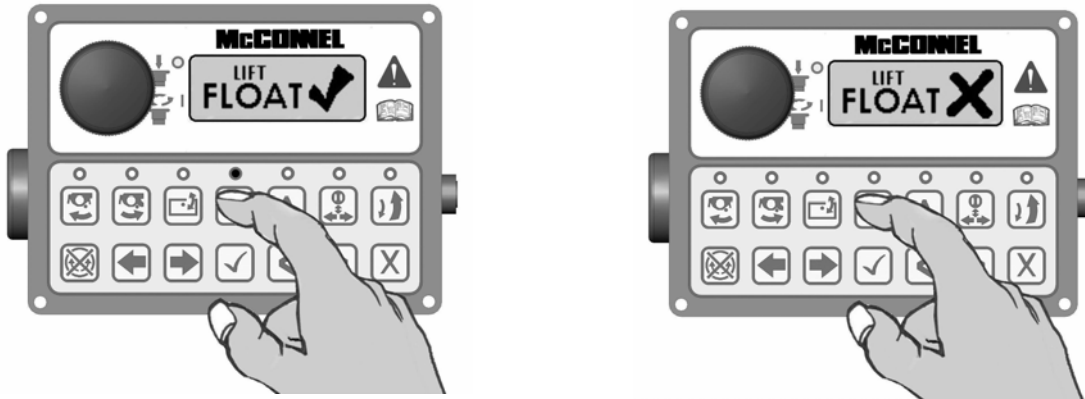

Press and hold in the lower frontal button (B1) on the joystick control and roll the right hand thumbwheel (T2) forwards – the control unit will emit a single beep, the LED light will illuminate and the screen will momentarily display 'LIFT FLOAT ✓'. To deselect press and hold in the lower frontal button (B1) on the joystick control and roll the right hand thumbwheel (T2) backwards – the control unit will emit a single beep, the LED light will go out and the screen will momentarily display 'LIFT FLOAT X'.

NOTE: When selecting or deselecting the function, the thumbwheel (T2) should be allowed to return to its centre position before releasing the lower frontal button (B1).



All models with v4.08 software onwards: With the function engaged subsequent operation of button B1 on the joystick or the [✓] button on the control unit will alternately disable and enable all active floats.

EDS models with pre v4.08 software: With the function engaged and the rotor running EDS settings (SOFT – MED – HARD) will automatically be displayed on the control unit screen and can be scrolled through using button B1 on the joystick or the tick [✓] button on the control unit, if the rotor is not running the EDS settings can manually be viewed on the screen by pressing either [◀] [▶] buttons on the control unit and scrolling to the EDS work screen.

NOTE: On machines fitted with EDS and Lift Float only one function can be used at any one time (EDS needs to be Activated/De-Activated via the on-screen menu)

AUXILIARY FUNCTION CONTROL

There are 3 possible types of auxiliary service control as described in A, B & C below – the particular type used will be dependant on the build specification of the machine. Control operation of the function for all types remains the same (see below).

A) Diverter Valve System Utilising an Existing Service (*Physical Diverter Valve*)

The control selects either of the two diverter valves for the operation of additional equipment that may be fitted to the machine such as: Directional Ram, Orbiter Head Kit, Hydraulic Roller etc.

B) 6/7 Service Manifold Systems (*Electronic Diverter Valve*)

Only available on stackable manifold systems either as a factory fitted option or as an aftermarket kit, in the case of the latter 'D1 and/or D2 PROP' will need to be changed from 'N' to 'Y' within 'options' of the setup menu on initial installation of the kit.

C) Integrated Debris Blower

Operated by D1 on machines with standard arm or D2 on machines with Tele, Midcut or VFR arms.

There are 2 methods of control available for selection and de-selection of the functions; activation via the control unit - refer to #1 below, or activation via the joystick controls - refer to #2 below.

1. Pressing the button momentarily will select Diverter Valve #1 – when activated the control unit will emit a single beep, the LED light will illuminate and the screen will momentarily display 'DIVERTER VALVE 1 ✓'. Pressing the button again momentarily will deactivate diverter #1, the screen will display 'DIVERTER VALVE 1 ✗'. Holding the button in for 2 seconds will select Diverter Valve #2 – when selected it remains active until it is subsequently deselected by holding the button in again for 2 seconds.

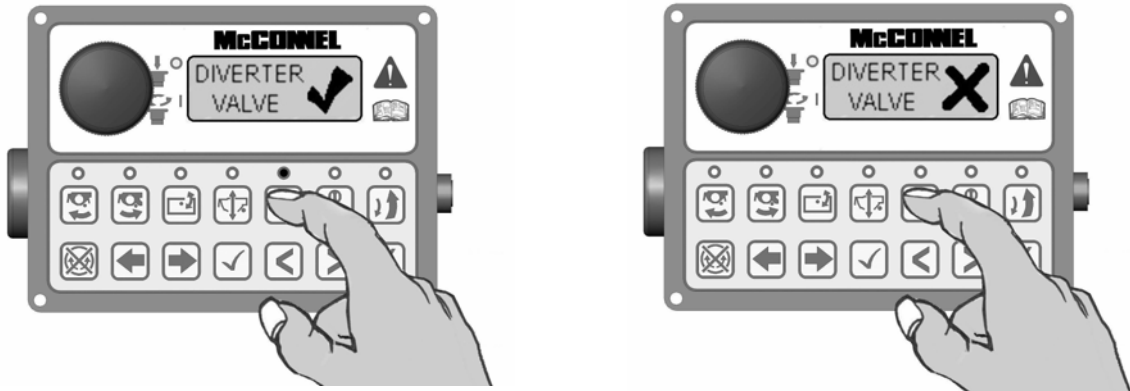

2. Pressing the upper frontal button (B2) on the joystick momentarily will select Diverter Valve #1 – when activated the control unit will emit a single beep, the LED light will illuminate and the screen will momentarily display 'DIVERTER VALVE 1 ✓'. Pressing the button again momentarily will deactivate diverter #1, the screen will display 'DIVERTER VALVE 1 ✗'. Holding button (B2) in for 2 seconds will select Diverter Valve #2 – when selected it remains active until it is subsequently deselected by holding the button in again for 2 seconds.



BREAKAWAY – 3RD RAM SWAP

This function swaps over the controls used to operate Breakaway and 3RD Ram. By default, Breakaway operation is performed with the right hand thumbwheel (T2) and 3RD Ram operation with the [◀] [▶] buttons on the control unit - in the swapped mode these will be the opposite way around and the LED on the control unit will be lit to indicate that the swapped mode is selected.

Swapping these controls is performed via the control unit - *refer to #1 below*. On machines installed with pre v4.08 software the same function could also be performed via the joystick controls – *for these models only refer also to #2 below*.

NOTE: 'BREAKAWAY/3RD RAM SWAP' mode is displayed on the control box screen as 'SLEW/TELE SWAP'.

1. Press the swap button once to select swap mode – when activated the control unit will emit a single beep, the LED light will illuminate and the screen will momentarily display 'SLEW/TELE SWAP ✓'. Pressing the button again will deselect the function – the control unit will emit a single beep, the LED light will go out and the screen will momentarily display 'SLEW/TELE SWAP X'.

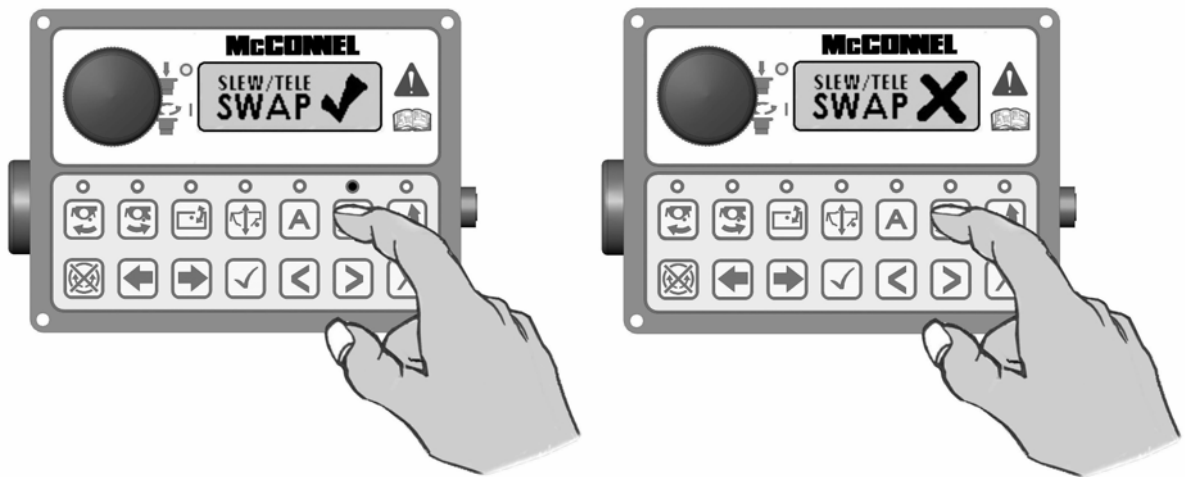

Models with pre v4.08 software only

2. Press the joysticks lower frontal button (B1) once to select swap mode – when activated the control unit will emit a single beep, the LED light will illuminate and the screen will momentarily display 'SLEW/TELE SWAP ✓'. De-selection is with subsequent use of the same button - the control unit will emit a single beep, the LED light will go out and the screen will momentarily display 'SLEW/TELE SWAP X'.



AUTO RESET

This button is for the selection and de-selection of the Auto Reset function – pressing the button once will activate Auto Reset, the control unit will emit a single beep, the LED light will illuminate and the screen will momentarily display 'AUTO RESET ✓'. Pressing the button again will deselect the function – the control unit will emit a single beep, the LED light will go out and the screen will momentarily display 'AUTO RESET X'.

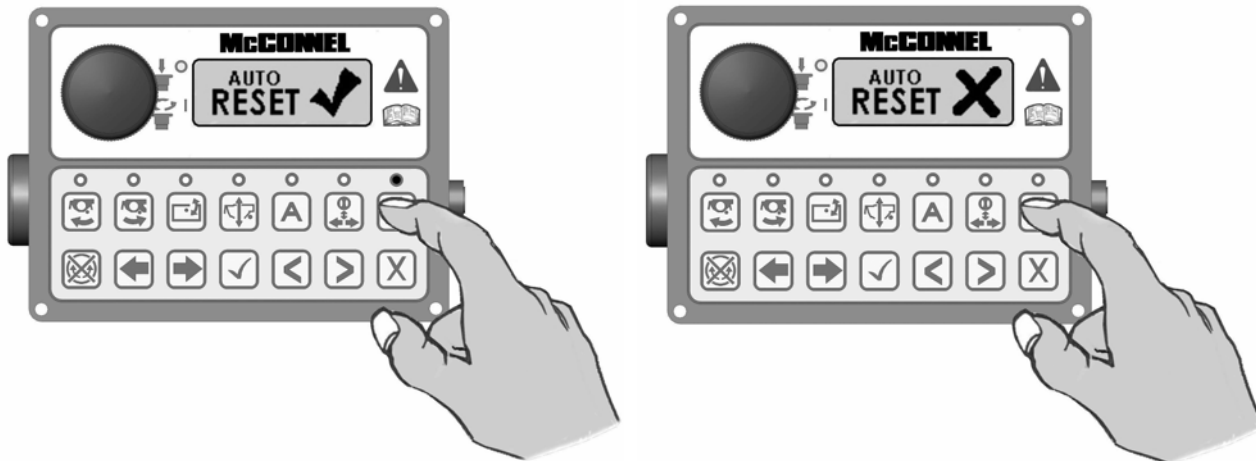

V4 JOYSTICK CONTROLS - Buttons & Thumbwheels Operation



NOTE: By default operation of thumbwheels T1 and T2 in conjunction with button B1 activates Head Angle Float and EDS/Lift Float respectively. These controls can, if required, be swapped over so that the thumbwheels operate the opposing functions – this procedure is performed by accessing the settings menu on the control unit via the screen and menu buttons.

LH/RH Swap Shortcut; Press and hold ✓ & X on Control Unit for 3 seconds (unit will 'bleep' to confirm).

FLOAT SELECTION & DE-SELECTION

Operate thumbwheels to their furthest points (+ or -) to select or deselect float functions.

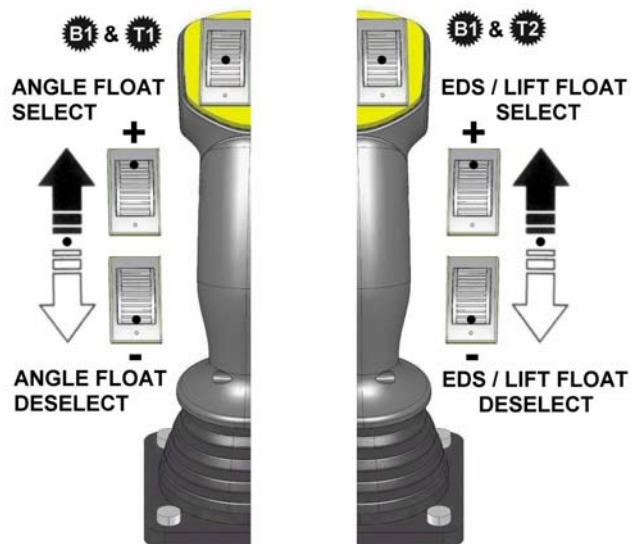

ANGLE & BREAKAWAY OPERATION

Rotate thumbwheels in required direction.



DIVERTER VALVE SELECTION

Diverter selection is via button B2



ARMHEAD OPERATION – JOYSTICK CONTROLS

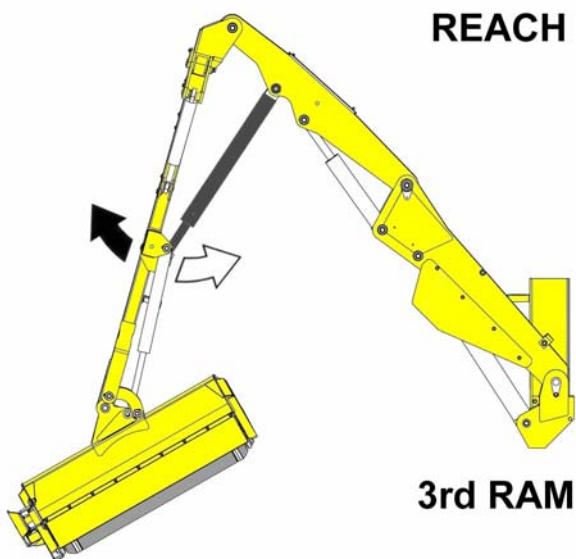
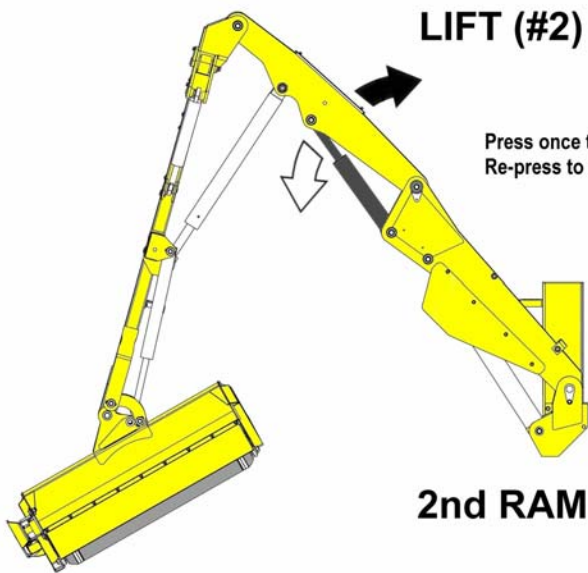
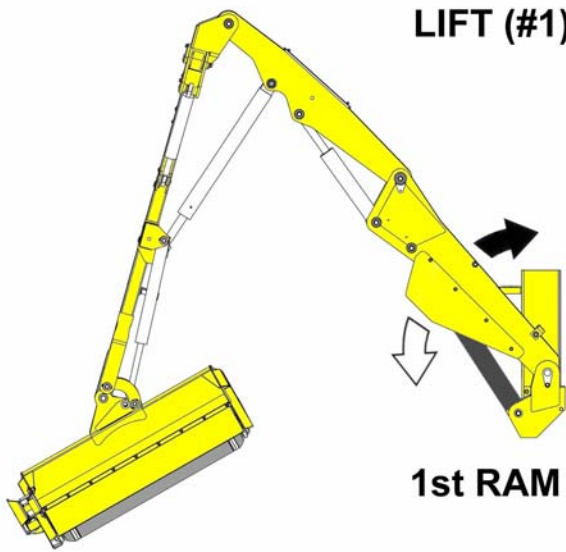

ARMHEAD OPERATION – JOYSTICK CONTROLS

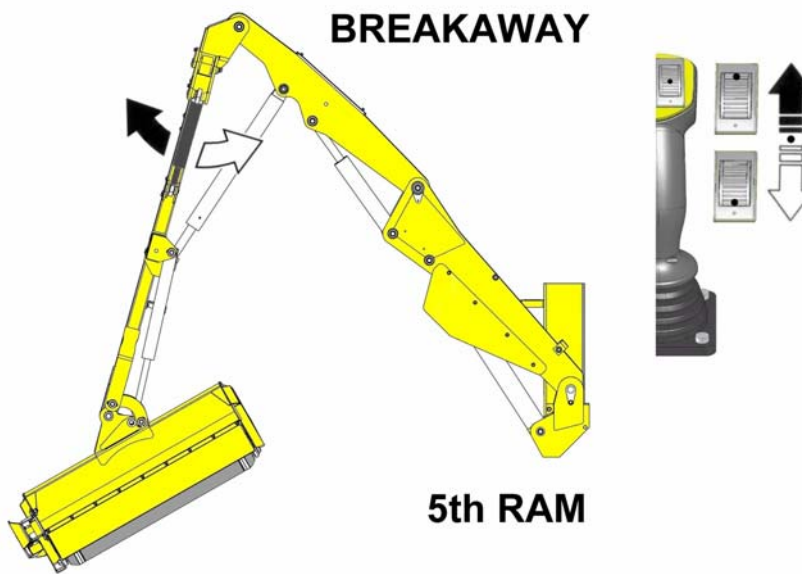
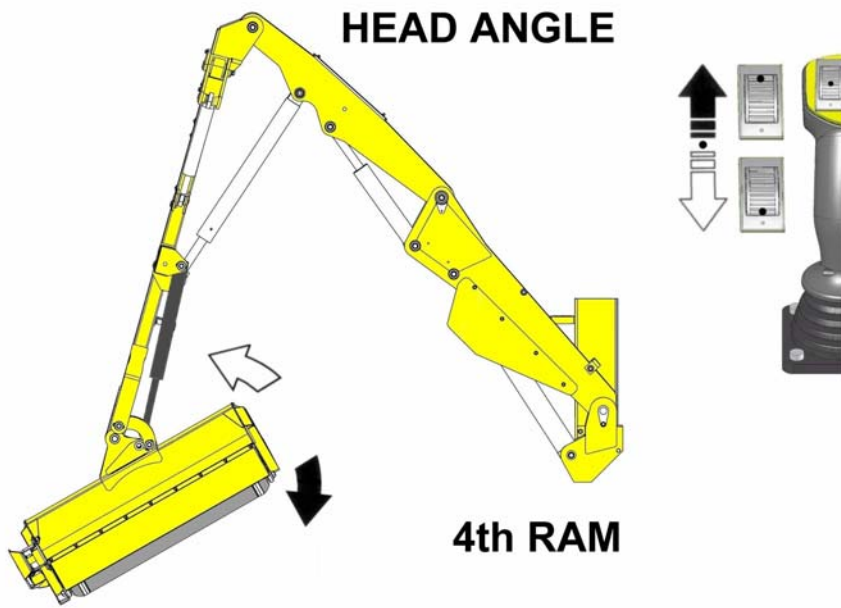

V4 CONTROL UNIT – Screen Access & Menu Buttons

Power on/off switch (E/Stop)

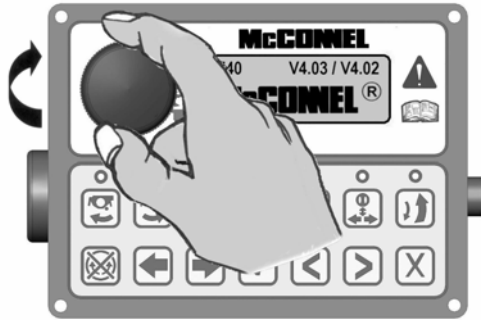

Speaker (audible confirmation)

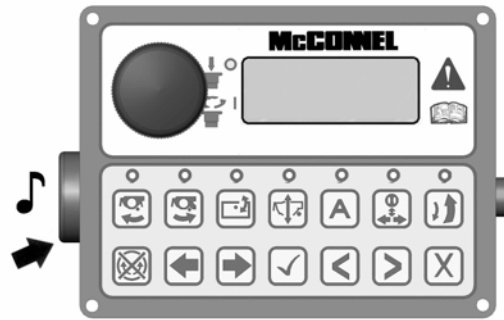

Control unit emits an audible confirmation 'beep' when the buttons are pressed.

Command Button [✓]

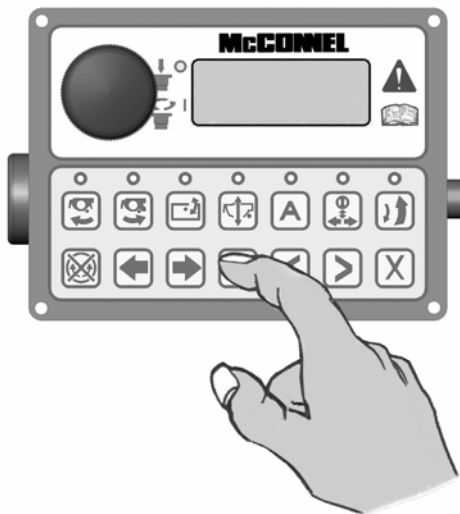

Command Button [X]

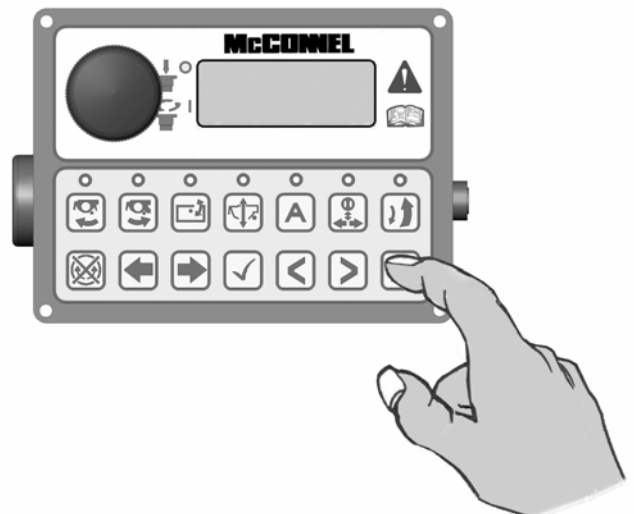

Navigate Forward Button [>]

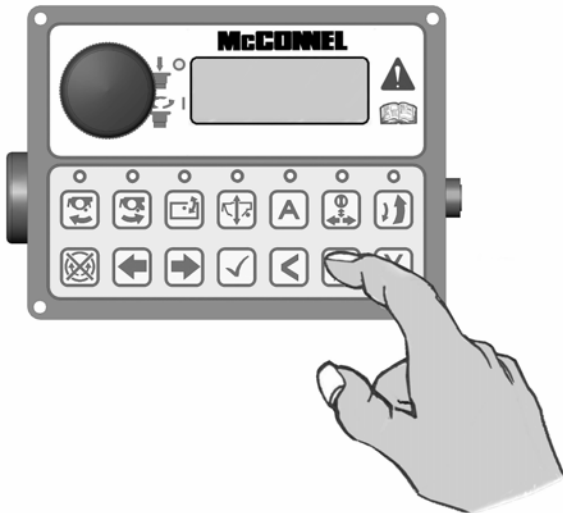

Navigate Back Button [<]



V4 CONTROL UNIT – LED Screen Display & Functions

IMPORTANT: Under no circumstances should a V4 Control Unit be connected to a V3 ACB (Auxiliary Control Box). Dedicated V3.5 & V4 Upgrade Kits are available from McConnel Limited – contact your local dealer or McConnel direct for available options and specific advice on this subject.

Rotate the ON/OFF switch on the control unit clockwise to power up controls - unit will emit a single beep and the LED screen will light up. *Note: 12 Volts at the battery is required for the unit to function correctly.*

1. Screen will initially display the 'McConnel' name along with the selected PTO speed and the software versions installed on the Armrest and the Control Box respectively.

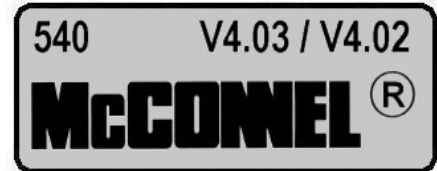

2. Pressing the scroll forward [▶] button once will display the rotor running times screen. 'TOT' displays the overall total running time of the rotor which is a cumulative total and cannot be reset. 'JOB' is a 'trip' total for the current rotor running time and can be reset to zero by pressing and holding the [X] button for 3 seconds.



3. Pressing either of the 'Rotor On' buttons will activate the 'egg timer' icon and display the rotor on image.



4. Pressing the EDS Lift float button will turn on the EDS (EDS Lift Float machines only). Then SOFT, MED or HARD will be added to the running screen.



5. Pressing the tick [✓] button when EDS is turned on will scroll through the EDS work settings of SOFT, MED or HARD. This may also be operated via button B1 on the joystick.

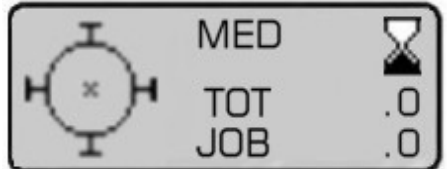

6. Pressing scroll forward [▶] button will now display the actual Tractor PTO running speed.



7. Scrolling forward [▶] again displays the Power Monitor screen.



Scrolling backwards [◀] will display the screens in the opposite order.

POWER MONITOR

When displayed the power screen will indicate to the operator the level of power being demanded by the cutting head – an ascending graphic indicates the power demand status from minimum on the left of the screen to maximum on the right.

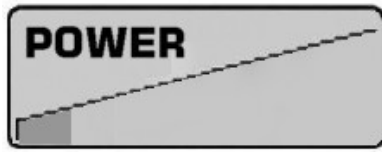

Power Status – Low Demand



Power Status – High Demand

When the power demand approaches the maximum limit an audible warning will alert the operator to indicate that the rotor is under excess load and at risk of ‘stalling’ – when this audible warning sounds the operator should reduce the forward tractor speed to protect the machine and regain efficient cutting power – the audible warning will cease when the power demand returns to an acceptable level.

In certain cases, cutting materials of extreme density may cause an increase in the power usage to the ‘warning level’ – in these types of conditions raising the cutting head into a less dense area of the material will regain an acceptable power demand. It is advisable that work in problematic high density materials be performed in several passes, lowering the cutting head slightly on each pass until the required cut height is achieved.

ADDITIONAL CONTROL & SCREEN SETTINGS

Additional settings available to the operator can be found within the settings menu of the control unit and accessible via the screen and menu buttons on the control panel.

Access is gained by simultaneously pressing the scroll [◀] [▶] buttons on the control panel until the unit emits a ‘beep’ and the setup screen appears on the LCD - the features can then be ‘scrolled’ to (forwards or backwards) by subsequent operation of either of the scroll [◀] [▶] buttons. When the required screen is reached the tick [✓] button should be pressed to enter the settings menu for that feature.

THUMB (Thumbwheel Switching) – this allows the operator to ‘swap over’ the left and right thumbwheel functions so that they control the opposing features. In most cases this setting will be dictated by the operators’ personal preference and once chosen the operator will keep it in the selected mode.

Options are ‘Normal’ or ‘Swap’ – selection is by ‘highlighting’ the required option using either of the scroll [◀] [▶] buttons – the feature is then activated using the tick [✓] button. Pressing the [X] button exits the screen settings and returns to the normal work screen.

LED (Screen Contrast) - this setting allows the operator to adjust the contrast level of the LED display – the feature affords the option to increase or decrease the contrast level to suit differing lighting conditions; this is particularly useful on dull or sunny days where reduced or increased natural light can affect screen clarity.

Options are ‘Increase Contrast’ or ‘Decrease Contrast’ – selection is by ‘highlighting’ the required option using either of the scroll [◀] [▶] buttons – once selected that particular option can then be adjusted in incremental steps by pressing the tick [✓] button the required number of times to achieve the desired contrast. Pressing the [X] button exits the screen settings and returns to the normal work screen.

CAUTION: Avoid adjusting the contrast level to a state where the screen cannot be viewed as exiting the settings menu in this condition may render the LCD unusable as the ‘on screen’ prompts may no longer be visible to the user.

NOTE: Some screen menus are inaccessible to the operator – these are for factory or dealer use only and are password protected to avoid inadvertent changes to specific control settings.

TEST & FAULT FINDING SCREENS

The following screens are available for testing and fault finding purposes, these are:

JOYSTICK TEST SCREEN

This screen reports the status of the CAN (*Controller Area Network*) signal from the joystick during its various functions.

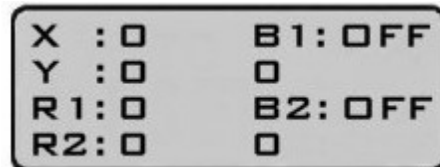

X and Y Display

These report the joystick signal as it travels through its range of movements in its 2 axis – the ‘X’ axis being the ‘Lift’ up and down function and the ‘Y’ axis the ‘Reach’ in and out function.

With the joystick in the central (*neutral*) position both ‘X’ and ‘Y’ on the screen should read 0 (*zero*). When the joystick is moved through a specific axis the relevant readout will increase or decrease depending on the direction and distance of movement up to a maximum of +1000 in the fully forward or fully right position and -1000 in the fully back or fully left position. If the display reports a reading above the + or – 1000 figure at any point of full travel the joystick has developed a fault and should be repaired or replaced.

R1 and R2 Display

These report the signals from the 2 thumbwheels on the top of the joystick and are calibrated to read +1000 in the fully back position and -1000 in the fully forward position. If either of the ‘R’ readings are above the + or – 1000 figure at the point of full travel the thumbwheel has developed a fault and should be repaired or replaced.

B1 and B2 Display

These report the status of the 2 joystick buttons and will display ‘ON’ when the button is activated or ‘OFF’ when deactivated. The readings below B1 and B2 on the screen record usage of the buttons.

EDS STATUS SCREEN

Although this screen is present on all v4 controls, with the exception of the voltage reading, the information it reports is only actually relevant to machines fitted with EDS.

In addition to the aforementioned voltage reading the screen will report Lift Ram Pressure and Reach Position status – in each case these will display ‘OK’ when the system is working correctly. If ‘FAULT’ is displayed next to one or other feature it means a problem has been detected with that component and it should be investigated further to locate and correct the problem.

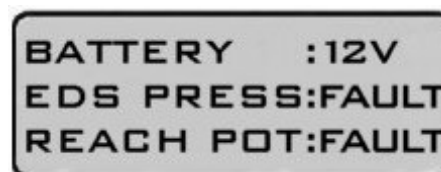
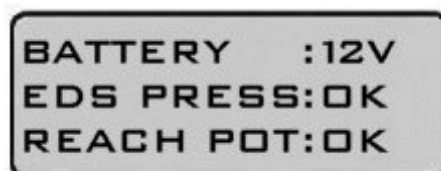

NOTE: As the pressure and position features are not present on Non EDS machines by default the screen will display ‘FAULT’ next to the features on these models – this is normal and should be ignored. The voltage reading will be relevant on all models.

REACH FUNCTION SCREEN

This screen displays the status of the joystick reach function and indicates to the operator if the controls are set for correct operation of the machine to the left hand side of the tractor or to the right hand side of the tractor. The hand symbol with a ✓ displayed on it indicates the operating side that is currently active.



L/H Machine Operation



R/H Machine Operation

NEW MACHINES: PREPARATION & GENERAL PRECAUTIONS

IMPORTANT: Always read the book first before attempting to operate the machine – practise operating the machine, without the rotor running, in a safe open space until you are fully familiar with all controls and functions of the machine. Only begin using the machine for work when you are confident that you have mastered the controls and operation sufficient for safe use of the machine.

CAUTION: Care must be taken when working with the flailhead close in to avoid contact with the tractor.

'Running In' a New Machine

For the first days work with a new machine it is recommended that tractor forward speed is restricted to 3 km/hr. (2 mph) maximum. This will allow machine components 'bed in' and allow the operator to become familiar with the controls and their response under working conditions whilst operating at a relatively slow speed. If possible, select a first days work that affords mainly light to average cutting with occasional heavy duty work – *during this period check the tightness of nuts and bolts after; one hour, four hours and again at the end of the day, retightening as and when required.*

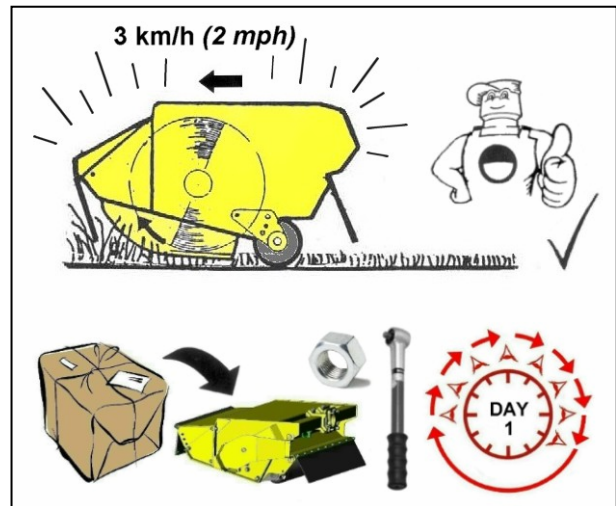

First use with a new machine ▲
Restrict forward speed
Check nut & bolt tightness regularly

General Work Precautions

Inspect the work area prior to operation, remove any hazardous materials and note any immovable objects - *it may also be a wise precaution to indicate these hazards with a visible marker than can be easily seen from the operating position in the tractor.*

If the type of work being undertaken makes this important precaution impractical, always maintain a high degree of alertness and restrict the tractors forward motion to a speed that allows sufficient time to stop the tractor or avoid the hazard before contact is made.

General Working Practice

It is the operator's responsibility to develop safe working procedures;

Always:

- Be aware of hazards in the vicinity.
- Ensure all guards are fitted correctly and in good condition.
- Disengage PTO before stopping the engine.
- Wait until the flail has stopped running before leaving the tractor seat.
- Disengage the PTO, stop the engine and pocket the key before making any adjustments.
- Check frequently that all nuts and bolts are tight.
- Keep bystanders at a safe distance.

PRE-WORK PREPARATION & PRECAUTIONS

IMPORTANT: Always read the book first before attempting to operate the machine – practise operating the machine, without the rotor running, in a safe open space until you are fully familiar with all controls and functions of the machine. Only begin using the machine for work when you are confident that you have mastered the controls and operation sufficient for safe use of the machine.

Pre-work Machine Checks

Prior to use of the machine always check all bolts are tight and that the torque figures are correct for the specific locations indicated below:

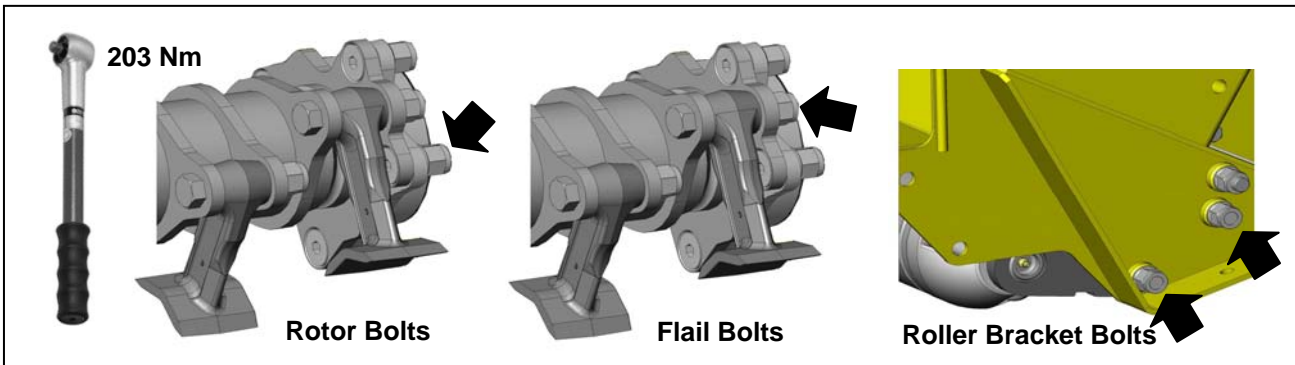
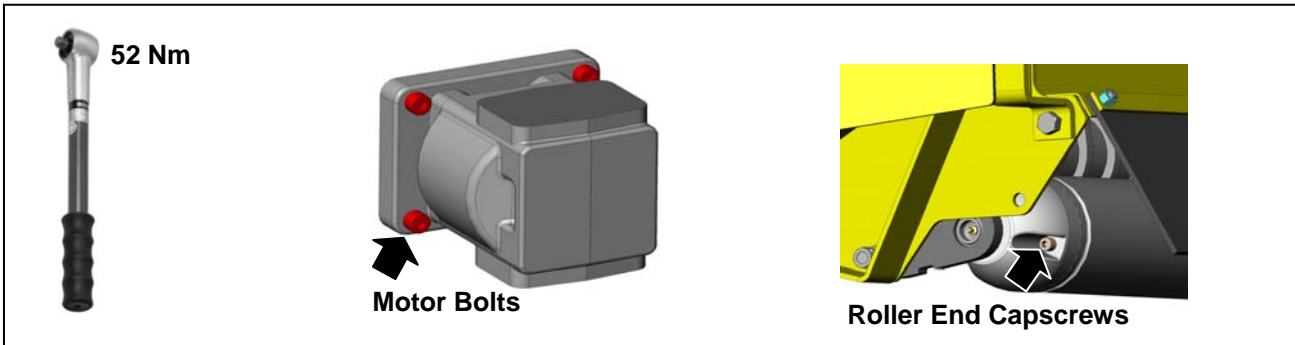

EMERGENCY STOPPING

In all emergency situations machine operation and functions must be stopped immediately; **Stop PTO operation** using the tractor controls then immediately kill electrical power to the machine using the **Off (Emergency Stop)** switch on the machine's control unit.

WARNING: Auto-Reset Machines



When the Auto-Reset feature is active the machines arm set is capable of unintentional movement even when the PTO is switched off and stationary. Always ensure that electrical power to the machine is switched off using the **Off (Emergency Stop)** switch on the machine's control unit in emergency situations and/or when the machine is not being operated.

WARNING: Cable Operated Machines



In certain conditions, and/or if the Auto-Reset feature is active, the arm sets on cable operated machines possess the potential to move unintentionally, even when the PTO is switched off and stationary, if the levers were to be accidentally operated. Care must be adopted to avoid any movement of the levers when the machine is not being operated. Ensure arm sets are lowered fully to the ground when the machine is parked up or not in use.

OPERATING SPEEDS

PTO Operating Speed

The correct PTO speeds for operation of machines are as follows:

Gear Machines: 500 - 540 rpm (Max)

Piston Machines: 800 - 830 rpm (Max)

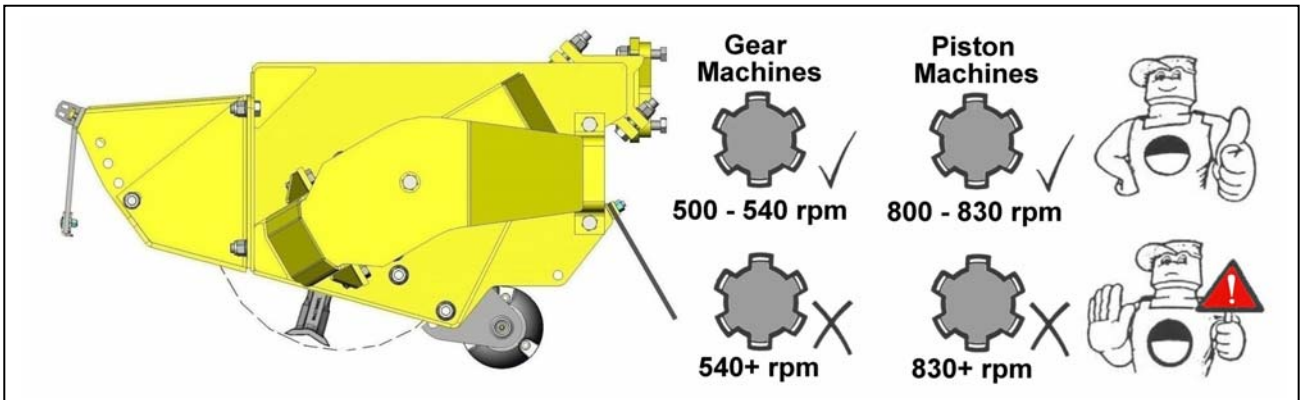

WARNING: Damage to the machine may occur if the maximum PTO speed is exceeded.

Engaging Drive

- Ensure the rotor control lever/switch is in the 'stop' position before engaging the PTO.
- Allow the oil to circulate for a minute or so before operating the armhead controls.
- Move the flail head into a safe working position just clear of the material to be cut.
- Increase engine speed to a high idle and start the rotor – after initial 'surging' the rotor will run at an even speed.
- Carefully lower the flail head into the work area and begin work.

Tractor Forward Speed

The material being cut will determine the tractor forward speed. Forward speed can be as fast as that which allows the flail head sufficient time to cut the vegetation both efficiently and neatly.

If forward speed is too fast this be indicated by over frequent operation of the breakaway system, a fall off in tractor revs and a poor untidy finish to the work leaving ragged uncut tufts and poorly mulched cuttings.

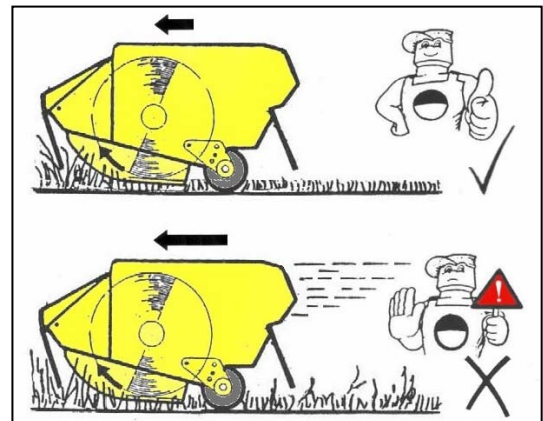

BREAKAWAY

The machine is fitted with a hydraulic breakaway device which protects the structure of the machine should an unforeseen obstacle be encountered.

NOTE

The breakaway function does not relieve the operator of his responsibility to drive carefully – always be alert and avoid obvious hazards before contact occurs.

Breakaway may occur momentarily during normal work should an extra thick or dense patch of vegetation be encountered. In these instances tractor forward motion may be maintained with care.

Where breakaway has occurred as a result of contacting a post or tree etc. the tractor must be halted and the controls of the machine utilised to manoeuvre the head away from the obstacle. **Never continue forward motion to drag the head around the obstacle in 'breakback' position.**

NOTE

The force required to activate the breakaway system will vary dependent upon the gradient of work – It will require less force when working uphill and vice versa.

The breakaway geometry will cause the head to initially move outwards in addition to rearwards, therefore be aware that the breakaway action will be impeded if the outer end of the head is working against a steep bank, In these circumstance extra care must be taken during operation to avoid this occurrence.

Re-setting the head into the work position is carried out manually by operation of the breakaway ram (Ram 5) using the control unit.

EASY DRIVE SYSTEM (EDS)

The Easy Drive System (EDS) is an optional extra on proportional machines with v3 or v4 digital controls – where fitted it provides 'hands free' cruise control operation with automatic head and lift float at greater working speed that increase both safety and efficiency.

The system comprises of sensors that measure rotational movement of the rocker pin and pressure variations in the lift ram circuit these are processed and forwarded to the hydraulic system which then regulates the optimum lift ram pressure to allow the arm and head to 'float' over changing ground contours. With readings taken and processed every 30 milliseconds the lift ram pressure is constantly and rapidly re-evaluated and adjusted.

Any movement of the joystick in the lift plane will automatically de-activate EDS, on release of the joystick the system will immediately be reverted back to EDS mode - *This is particularly useful feature for manoeuvring the machine around obstructions.*

The EDS system has 3 user settings available for differing operating conditions – these are soft, medium and hard. For machines where EDS is installed refer to the specific control section for details of operation.

LIFT FLOAT (Optional Extra for Ground Work)

Work without lift float requires far more concentration and input from the operator to quickly react and re-adjust to the ground contours often resulting in patches of higher cut material where the head is cutting too high and ‘scalping’ of the ground where it is cutting too low – *in the case of the latter this can lead to increased flail wear, damage or even loss of flails.*

The Lift float feature is an optional extra for use during mowing work. When the function is activated the pressurised accumulator(s) work in conjunction with the valve and lift ram to take a proportion of the flail heads weight off the flail roller allowing the head to automatically follow the natural contours of the ground; this produces a cleaner more uniform cut without the need for constant operator re-adjustment. On EDS models the function has 3 user settings for differing working conditions – these are soft, medium and hard. *Refer to the relevant control section for details of selecting the required setting.*

Operation of the lift float function is as follows: with lift float switched off, position the flail head approximately 1m clear of the ground before switching the float function on to charge the accumulator(s) – *the arms may drop at this point depending on the current level of retained pressure.* Lower the flail head into the work position, release the lift control and proceed to work. **NOTE:** *with the exception of EDS models, occasional operation of the lift function will be required when working on downhill or uphill slopes and when reaching in or out in order to replenish the oil level within the accumulator(s) to retain optimum float capability.*

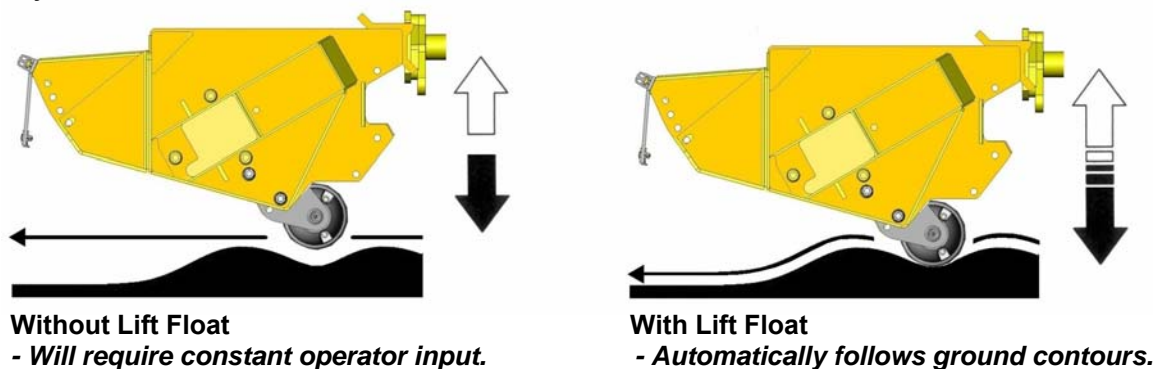

Lift float operation when supplied as a factory fitted option is controlled from the control unit that accompanied the machine (*refer to controls section for details*), but the feature is also available for a range of models as an after market kit, in which case operation will either be by utilisation of the auxiliary three-position type switch on the control unit of electric controlled machines - *this will allow for selection of 'lift float alone' or 'lift and angle float in unison' if both features are fitted.* Operation of the lift float control for these models will then be as specified in the main controls section.

Power Connection on Electric Machines

On electric controlled machines power to the unit is via the following connections:

Machines with 14 core looms use connection 10 and common connection 11.

Machines with 19 core looms use connection 15 and common connection 16.

V3 and V4 Non-EDS proportional machines use connections LF and C.

Depending on the particular machine after market lift float kits will either be frame mounted or ram mounted – they should be fitted and positioned in a location where they do not foul or interfere with other components during normal movements of the machine.

HEDGECUTTING PROCEDURE

Cut the side and bottom of the field side first. This leaves the maximum thickness of hedge on the road side to prevent the possibility of any debris being thrown through the hedge into the path of oncoming vehicles.

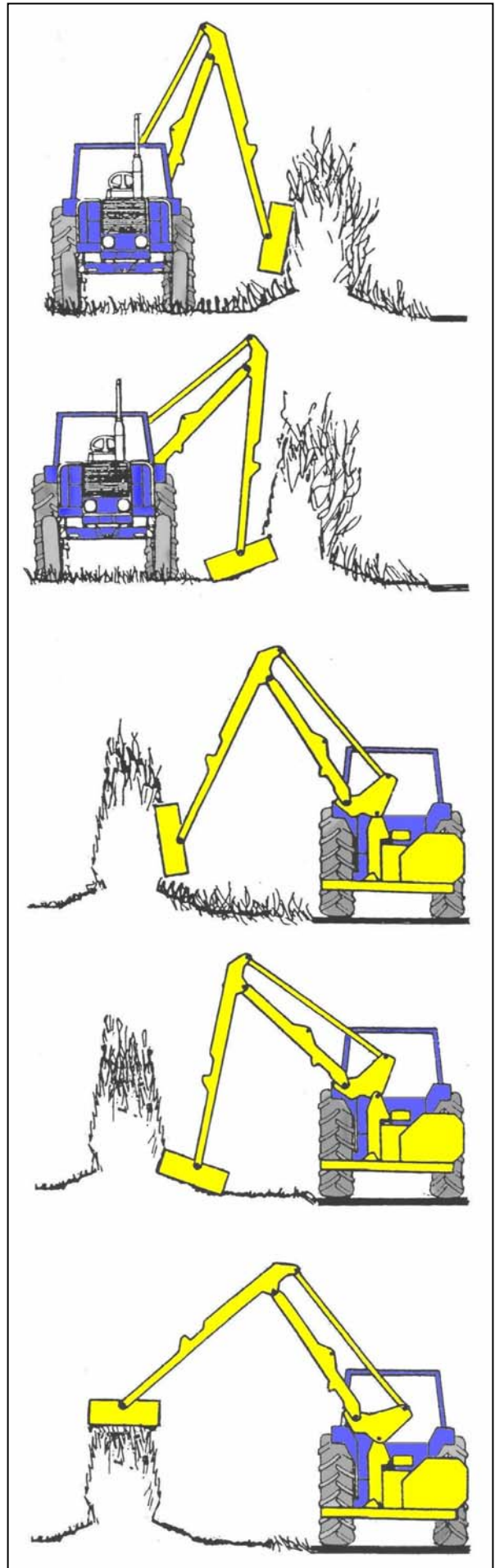

Cut the side and bottom of the road side.

Top cut the hedge to the height required.

HAZARDS & DANGERS

Working on Slopes

Extra care must be adopted when working on slopes, never risk working the machine in any conditions where it may cause the tractor to become unstable.

DANGER!



NEVER CUT TO THE BLIND SIDE OF A HEDGE
- it is impossible to see any potential hazards or dangers and the position of the flail head would allow debris to be propelled through the hedge towards the tractor and operator.

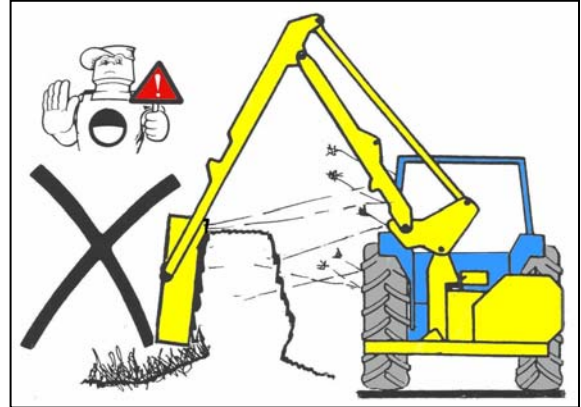

DANGER!



NEVER OPERATE THE MACHINE WITH THE FLAIL HEAD ROLLER REMOVED

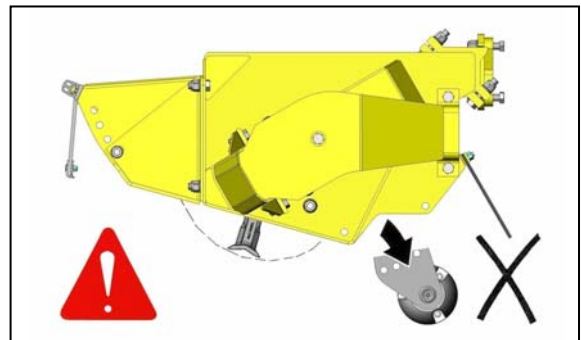

DANGER!



WHEN GRASS MOWING THE ROTOR MUST ALWAYS CUT IN THE UPHILL DIRECTION WITH FRONT HOOD FITTED AND THE ROLLER POSITIONED BELOW THE CUTTING HEIGHT OF THE FLAILS

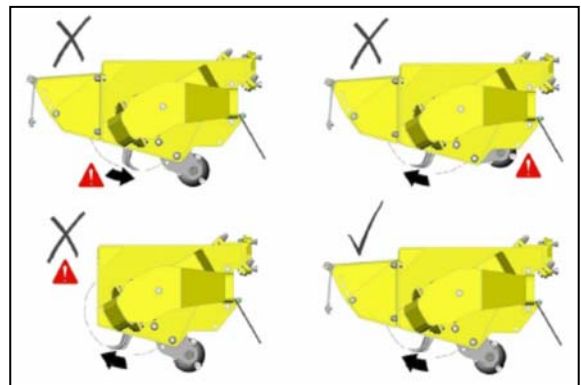

OVERHEAD POWER LINES (OHPLs)

It cannot be stressed enough the dangers involved when working in the vicinity of Overhead Power Lines (OHPLs). Some of our machines are capable of reach in excess of 8 metres (26'); they have the potential to well exceed, by possibly 3 metres (9' 9"), the lowest legal minimum height of 5.2 metres from the ground for 11,000 and 33,000 volt power lines.

Remember electrocution can occur without actually coming into contact with a power line as electricity can 'flashover' when machinery gets close to it.



WARNING: All operators must read the following information and be aware of the risks and dangers involved when working in the vicinity of Overhead Power Lines (OHPLs).

Wherever possible the safest option is always to avoid working in areas close to OHPLs. Where unavoidable, all operators must perform a risk assessment and implement a safe procedure and system of work – see *following page for details*. All operators should perform a risk assessment before operating the machine within 10m horizontal distance of any OHPLs.

Minimum Heights for Overhead Power Lines

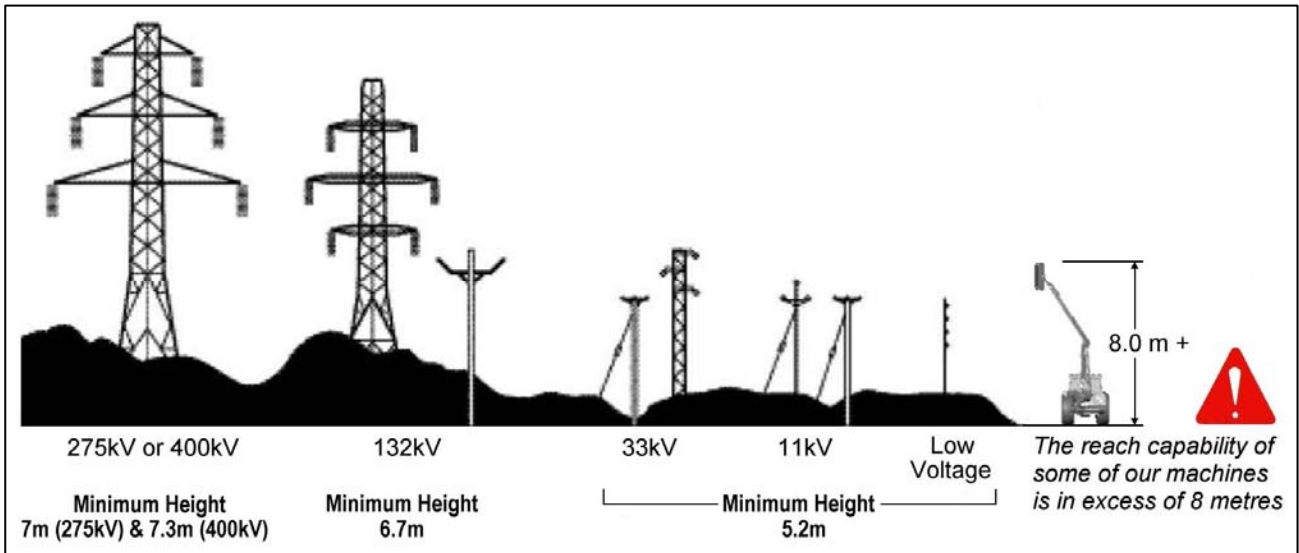

Absolute Minimum Exclusion Zones for Specific Overhead Power Lines

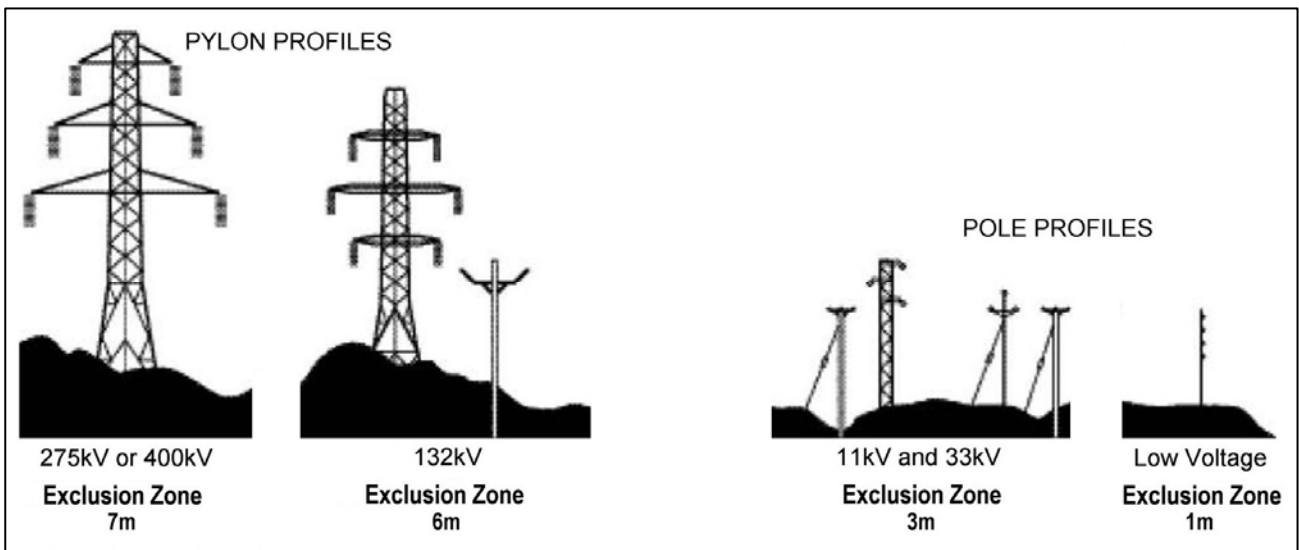

Definitions of Exclusion Zones

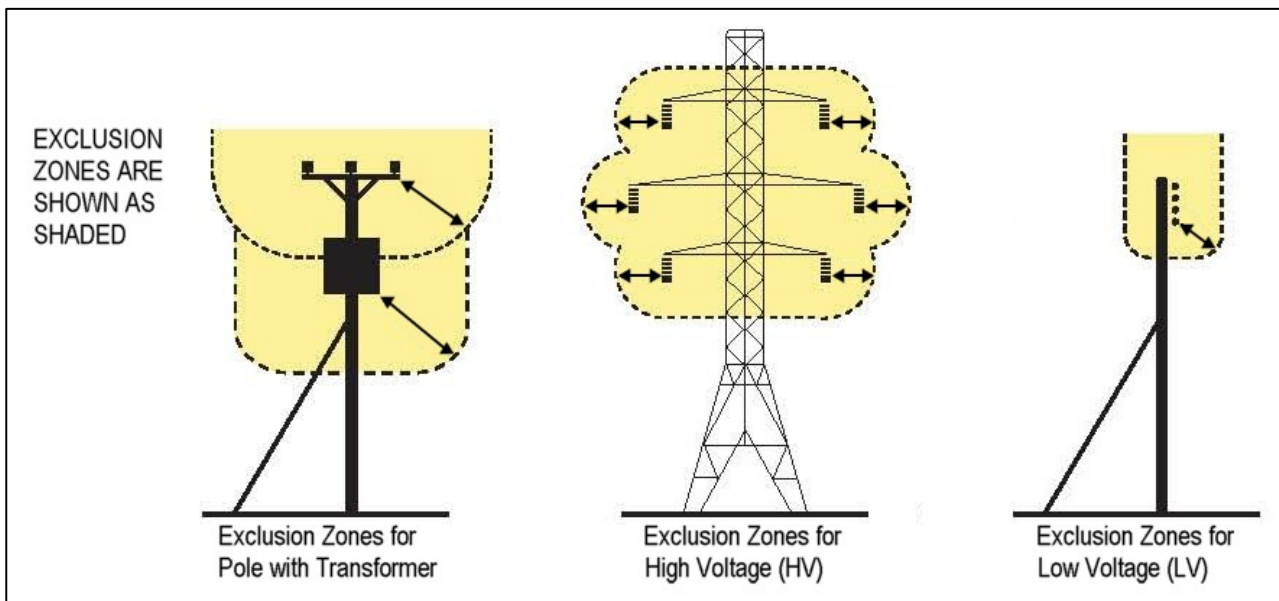

Risk Assessment

Before starting to work near OHPLs you should always assess the risks. The following points should be observed;

- **Know** the risks of contacting OHPLs and the risk of flashover.
- **Find out** the maximum height and maximum vertical reach of your machine.
- **Find out** the location and route of all Power Lines within the work area.
- **Find out** the operating voltage of all Power Lines within the work area.
- **Contact** the local Distribution Network Operator (DNO) who will be able to advise you on the operating voltage, safe minimum clearance distance for working, and additional precautions required.
- **Never** attempt to operate the machine in exclusion zones.
- **Always** work with extreme caution and plan your work ahead to avoid high risk areas.
- **If doubt exists** do not work in the area – never risk the safety of yourself or others.

Emergency Action for Accidents Involving Electricity

- Never touch an overhead line - even if it has been brought down by machinery, or has fallen. Never assume lines are dead.
- When a machine is in contact with an overhead line, electrocution is possible if anyone touches both the machine and the ground. Stay in the machine and lower any raised parts in contact or drive the machine out of the lines if you can.
- If you need to get out to summon help or because of fire, jump out as far as you can without touching any wires or the machine - keep upright and away.
- Get the electricity company to disconnect the supply. Even if the line appears dead, do not touch it - automatic switching may reconnect the power.

Further information and leaflets on this and other agricultural safety subjects are available on the 'Health & Safety Executive' website at the following address: www.hse.gov.uk/pubns/agindex.htm

FLAIL TYPES

Grass Flails

Designed specifically for general mowing activities – low power usage, ideal for cutting materials of low density.

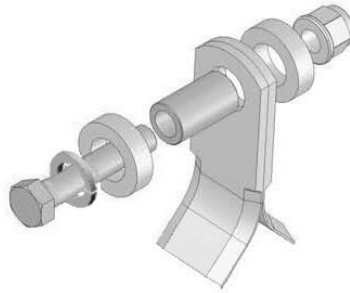

F10 Grass Flail
(Part No. 7190315)

Universal Boot Flails

Designed for general purpose work - suitable for mowing duties and the cutting of hedges with up to 2 years growth.

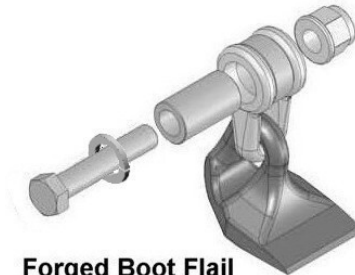

Forged Boot Flail
(Part No. 7190462)

Hedge Flails

Double edged flail designed specifically for heavy duty hedge cutting - capable of cutting materials up to 75/80mm diameter. Can be used for mowing work where they produce a good finish but will require considerably more power and reduced forward speed when used for this purpose.

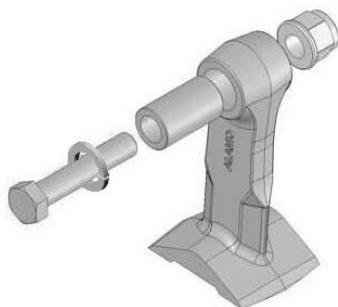

F10 D.E. Forged Flail
(Part No. 41391.02)

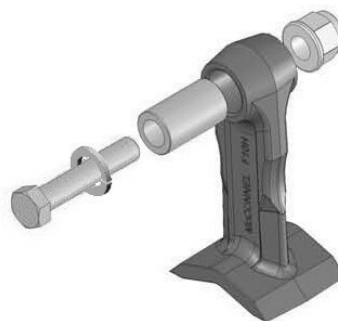

F10 D.E. Cast Flail
(Part No. 7314366D)

NOTE: Cast flails are more suitable where the work is predominantly hedge cutting as they maintain a sharper cutting edge – forged versions possess a higher degree of durability and are therefore more suitable where the primary function is mowing work and there is increased risk of hitting foreign objects.

Hedge Flails

Double edged flail designed specifically for heavy duty hedge cutting, capable of cutting materials up to 75/80mm diameter. Can be used for mowing work where they produce a good finish but will require considerably more power when used for this purpose. The flails are fitted with rubber stops for both shaft protection and noise reduction purposes.

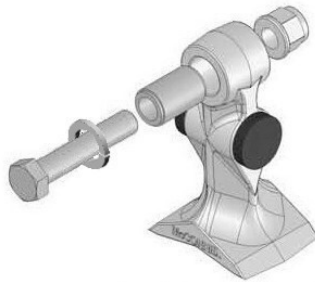

F16 D.E. Cast Flail
(Part No. 21904.02)

Competition Flails

Single edged flail designed specifically for heavy duty hedge and grass cutting, capable of dealing with materials up to 75/80mm diameter. When used for mowing work they produce a better finish and performance than double edged flails requiring less power and increased forward speed.

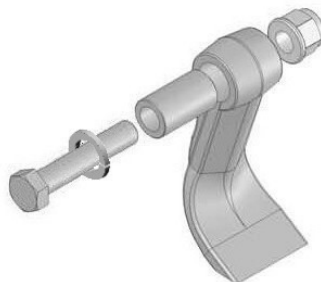

F10 S.E. Cast Flail
(Part No. 7390276)

Omega Flails

Double edged flail for use on 'Omega' rotors only - designed specifically for heavy duty hedge cutting where they are capable of cutting materials up to 75/80mm diameter. Unique rotor design allows the flail to rotate 360° on its pivot protecting the flail on impact with immovable objects. Not suitable for mowing work.

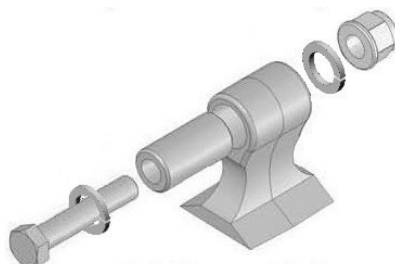

D.E. Omega Flail
(Part No. 7190464)

SERVICE INSTRUCTION - LUBRICATION

1.	Roller Bearings	4-5 shots daily	BP Energrease EP2G
2.	Cutting head, ram & arm pivots, breakaway swivel pin, kingpost socket	Fill weekly until grease exudes from joints.	BP Energrease EP2G
3.	Rotor shaft bearings	2-3 shots daily – do not overfill	BP Energrease EP2G
4.	Drive couplings	5-6 shots every week.	BP Energrease EP2G
5.	Ram pivots not fitted with grease nipples	A few drops of oil daily.	Tractor gearbox oil 20
A.	Hydraulic tank	Capacity 227 Litres (50 Gallons) Top up daily to sight gauge on tank. Do not mix grades, use clean oil only and fill through cap filter. Change oil completely every 1000 hours.	BP Energol HLP46 <i>or exact equivalent</i>
B.	Gearbox	Capacity 0.7L. Check daily for leaks. Change oil after initial 50 hours of use and thereafter at annual 500 hour intervals, whichever occurs earliest.	SAE90
C.	Pump drive shaft	Yoke – grease nipples every 500 hours fill until grease exudes from joints. Sliding shaft – keep well smeared with grease at all times.	BP Energrease EP2G

Check all oil levels and maintain using the correct grade of clean, water free lubricant.

Filters

Change the hydraulic filters after the first 50 hours and then every 500 hours running or when the indicator fitted to the filter housing is in the RED position. There are two filters on the rotor circuit and one on the arm circuit.

GENERAL SERVICING

Servicing Rotor and Rotor Bearings (Econ Flail head only)

To dismantle a rotor, rotor bearing and motor assembly, first remove the motor guard and disconnect the hose connections to the motor. It is important either to plug the hoses, or connect them together using an adaptor - if left open on the ground they will siphon empty the hydraulic tank. **Keep hoses and connections clean at all times.**

For easy access now turn the cutting head so that the end opposite the motor stands on the ground, the rotor shaft now being in the vertical position - the end plate should be rested on blocks to give a ground clearance of 4" (100mm) - this allows space for the bearing bolts to be removed.

Remove the bolts holding the motor and bearing to the end plate - withdraw the motor vertically from the rotor shaft, being careful not to lose the 6 drive rollers which may be sticking to the motor drive adaptor. Turn the rotor shaft until it is possible to unfasten the grub screws in the bearing collar. (Note: these circular flanges are only fitted on certain machines). In 1973 new bearings with additional covers were fitted, there are two holes in the circular flanges at the end of the rotor shaft which allow access for the allen key. Remove bolts from the other bearing through the hole where the motor has been removed, tap the bearing down onto the shaft and withdraw the rotor shaft complete with its bearings from the mainframe.

Remove the circlip, from the drive end. The bearing can now carefully be knocked off the rotor shaft using a wood or leather mallet. Check the bearings for excessive wear on the ball race seat, on the spherical ball seat and also check if the seals are intact.

When assembling the rotor, reverse the previous operations to the point of refitting the motor. At this stage the bottom (nearest ground) bearing bolts should be in place but not tightened and the top bearing in line with the holes in the end plate. Locate the six drive rollers in the motor drive adaptor holding them in place with either thick grease or a rubber band. Line the six rollers up with the mating holes in the end of the rotor shaft and fit carefully together, allowing the motor spigot to locate through the hole in the end plate and into the mating recess in the bearing housing.

Now fit the bolts and 'feel' the motor shaft and bearing into a free concentric position before tightening the bolts by moving the rotor end bearing on its loose bolts. The rotor shaft should rotate freely without tight spots after these bolts are tightly secured. Fasten the bottom bearing bolts, grub screws in the bearings, hoses and motor guard. In fitting the bearings remember to position the grease nipple in an accessible position for lubricating it.

The rotor, whilst dismantled, should be checked for straightness - maximum bow at centre is 1/16th of an inch (0.58mm) - flail lugs checked for weld fatigue, loss of balance weights from end 10" diameter plates. If there is any undue vibration when the rotor is running, then this is almost certainly caused by unbalance. If you have any doubt, return the rotor (minus flails) for factory re-balance. Always check that a complete set of flails is fitted, replace broken ones and also ensure that they are free to swing in their attachment.

SYMPTOMS & FAULTS

Hydraulic Circuits - Fault Location & Remedy Test Kit

The test kit comprises the following items:

1. Relief valve
2. High pressure gauge
3. Low pressure gauge
4. Blanking plug

Always disengage PTO drive to pump and stop tractor engine when carrying out physical inspection of cutting head rotor.

Always place cutting head firmly upon the ground, away from loose debris when carrying out performance checks upon the hydraulic circuits.

Symptom

Possible Fault

1. Rotor does not turn.

- a) Key failure in motor drive coupling indicated if when turning the rotor by hand, no back pressure resistance is felt in the motor.
- b) Obstruction jamming rotor e.g. length of wood or metal, wire wrapped round bearing etc. - remove.
- c) Trapped or kinked hoses - inspect and straighten or replace as necessary.
- d) Empty oil tank.
- e) Faulty pump - see check-out one.
- f) Faulty motor - see check-out three
- g) Faulty relief valve - see check-out one.
- h) Faulty solenoid valve or power connection.

2. Rotor running too slow.

- a) Faulty relief valve - see check-out one.
- b) Faulty pump - see check-out one.
- c) Faulty motor - see check-out three.
- d) Filter blockage - see check-out two.
- e) Blocked or kinked hoses - inspect and, straighten or replace as necessary.
- f) Aerated oil - frothiness caused by air being sucked into the oil circuit = check & tighten all connections. Either replace oil or allow oil to settle and separate.
- g) Faulty solenoid valve.

3. Rotor runs at specified speed but with apparent loss of power.

- a) Faulty relief valve - see check-out one.
- b) Faulty pump - see check-out one.
- c) Faulty motor - see check-out three.
- d) Blocked return line filter - see check out two.
- e) Blocked or kinked hoses - inspect and straighten or replace as necessary.

4. Rotor keeps stalling during cutting operation.
- a)
 - b)
 - c) All as section 3.
 - d)
 - e)
5. Oil leaking from
- a) Motor seat burst caused by excessive back pressure - see check-out two.
 - b) Pipe restricted - inspect and remove restriction or replace pipe
6. Noisy pump
- a) Loose hose connections allowing air to be drawn into pump - tighten connections.
 - b) Aerated or foaming oil - tighten connections, change oil or allow to settle and oil/air to separate.
 - c) Faulty pump - see check-out one.
 - d) Weld cracked on standpipe - re-weld or replace.
7. Noisy motor
- a) Aerated or foamy oil - tighten all connections, change oil or allow to settle and oil/air mixture to separate.
 - b) Faulty motor - see check-out three.

System Checks

Check 1:

Faulty relief valve or faulty pump.

Fit high pressure gauge to relief valve. Disconnect hose connecting valve to motor at valve connection. Operate valve manually and check pressure, setting should be 2600 lb/in² (179 Bar).

Check 2:

Faulty filter or blocked return on motor circuit.

Connect low pressure gauge. Start engine, run PTO up to speed and should the gauge reading exceed 30 lb/in² (2.0 Bar) then the filter elements should be changed. If this does not reduce the back pressure the filter should be dismantled and the internal bypass valve cleaned. Check hoses for blockage or kinking. The average gauge reading during operation should be 20 lb/in² (1.4 Bar).

Check 3:

Faulty Motor.

If the pump is OK and relief valve is OK and there are no leaks in the pressure lines but rotor is running under speed, the motor may be faulty. It will either need a new seal kit, if only a few years old or a new motor. Try replacing the seals first as they are the cheapest to replace.

If no significant improvement is obtained, replace motor.

Servicing Note

Absolute cleanliness is vital when doing any repairs to hydraulic valves, motors etc. They must be thoroughly cleaned before any attempt to remove them from the machine and kept scrupulously clean during maintenance and assembly. Where doubt exists it is best to leave work of this nature to a reputable dealer.

Hydraulic System Overheating

An excessive build up of heat (over 50°C) in any hydraulic system is invariably caused by the 'blowing off' of the relief valve.

The 'blowing off' may well be caused by either wrappage around the rotor bearings, the partial collapse of a hydraulic hose, the partial trapping of a hose, dirt in the relief valve itself so that it does not close, or badly worn hydraulic components caused by dirt in the system.

If you require any further assistance or information on the operation of this machine, please contact:

McCONNEL LIMITED

Temeside Works

Ludlow

Shropshire SY8 1JL

England

Telephone: 01584 873131

Facsimile: 01584 876463

Email: service@mccannel.com

Website: www.mccannel.com

HYDRAULIC SYSTEM

Oil Supply

Check the oil level in the reservoir daily.

Oil Condition & Replacement

No fixed time period can be quoted for oil changes as operating conditions can vary widely but a visually inspection of the oil will often indicate its current overall state. Signs of a reduction in its condition will be apparent by changes in colour and appearance when compared to new oil. Oil in poor condition can be dark, smell rancid or burnt, or in some cases be yellow, unclear or milky in appearance indicating the presence of air or emulsified water. Moisture resulting from condensation can become entrapped in the oil causing emulsification that can block the return line filter, consequentially the filter system will be by-passed and the oil and any possible contaminants present will continue to circulate without filtration risking damage to hydraulic components. All are indications or conditions that will require replacement of the oil.

Hydraulic oil is a vital component of the machine; contaminated oil is the root cause of 70% of all hydraulic system failures. Contamination can be reduced by the following:

- Cleaning around the reservoir cap before removal, and keeping the tank area clean.
- Use of clean containers when replenishing the system.
- Regular servicing of the filtration system.

Filtration System

Machines are protected by both replaceable 125 micron suction strainers and low pressure 25 micron full flow return line filters – the diagram below is a ‘scaled up’ view illustrating the filtering capability built into the hydraulic system of the machine:

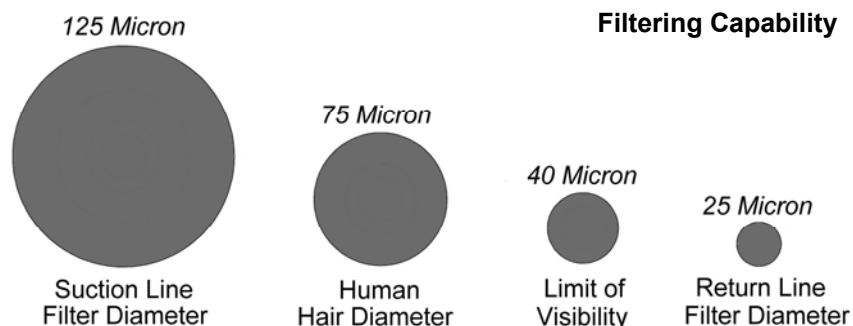

Suction strainers

The replaceable 125 micron suction strainers (*Part No. 8401097*) are fitted within the hydraulic tank and are ‘screw’ fitted with easy access for removal and replacement.

Return Line Filter

The 25 micron absolute filter elements (*Part No. 8401089*) should be changed after the first 50 hours and thereafter at 500-hour intervals. It is important to note hours worked as if the filter becomes blocked an internal by-pass within the canister will operate and no symptoms of filter malfunction will occur to jog your memory.

Tank Breather

To reduce the risk of pump cavitation it is advisable to replace the 25 micron absolute tank breather (*Part No. 8401014*) on an annual basis under normal working conditions – for machines operating in dry dusty environments it is recommended that replacement be increased to 6 monthly.

HYDRAULIC HOSES

The condition of all hoses should be carefully checked during routine service of the machine. Hoses that have been chaffed or damaged on their outer casing should be securely wrapped with waterproof adhesive tape to stop the metal braid from rusting. Hoses that have suffered damage to the metal braid should be changed at the earliest opportunity.

Hose Replacement

Before changing any hoses take the time to study the existing installation as the routing has been carefully calculated to prevent hose damage during operation - always replace hoses in exactly the same location and manner. This is especially important for the flail hoses where they must be crossed, upper to lower, at the dipper and head pivots.

- Always replace one hose at a time to avoid the risk of wrong connections.
- When the hose is screwed to an additional fitting or union, use a second spanner on the union to avoid breaking both seals.
- Do not use jointing compound on the threads.
- Avoid twisting the hose. Adjust the hose line to ensure freedom from rubbing or trapping before tightening hose end connections.

All Hydraulic Hoses (BSP) now fitted to McConnel Power Arm Hedge/Grass Cutters have 'soft seal' connections on both flail and ram circuit hoses.

Recommended torque settings for nut security are as follows:

SIZE		TORQUE SETTING			O Ring Ref.
1/4" BSP	=	24 Nm	or	18 lb.ft.	10 000 01
3/8" BSP	=	33 Nm	or	24 lb.ft.	10 000 02
1/2" BSP	=	44 Nm	or	35 lb.ft.	10 000 03
5/8" BSP	=	58 Nm	or	43 lb.ft.	10 000 04
3/4" BSP	=	84 Nm	or	62 lb.ft.	10 000 05
1" BSP	=	115 Nm	or	85 lb.ft.	10 000 06

For hose unions (BSP) fitted in conjunction with bonded seals the recommended torque settings are as follows:

SIZE		TORQUE SETTING			
1/4" BSP	=	34 Nm	or	25 lb.ft.	
3/8" BSP	=	75 Nm	or	55 lb.ft.	
1/2" BSP	=	102 Nm	or	75 lb.ft.	
5/8" BSP	=	122 Nm	or	90 lb.ft.	
3/4" BSP	=	183 Nm	or	135 lb.ft.	
1" BSP	=	203 Nm	or	150 lb.ft.	

Safety Note:

Soft seal hose connections are capable of holding pressure when the nut is only 'finger tight'. It is therefore recommended during dismantling that the hose be manually flexed to relieve any residual pressure with the retaining nut slackened prior to complete disassembly.

PTO SHAFT MAINTENANCE

PTO Shaft Lubrication

The PTO shaft should be lubricated on a regular basis using lithium based grease – each end of the shaft has 2 greasing points; one for lubrication of the universal joint and one for lubricating the rotating fixing ring of the shaft shield – access to the lubrication points is gained by releasing the shaft shield from its fixing ring and sliding it back along the body of the driveshaft – *the procedure and lubrication frequency is illustrated below.*



Shaft shield fixing clasps



Insert screwdrivers into the clasps



Prise clasps open to release the shield



Slide shield back to reveal universal joint

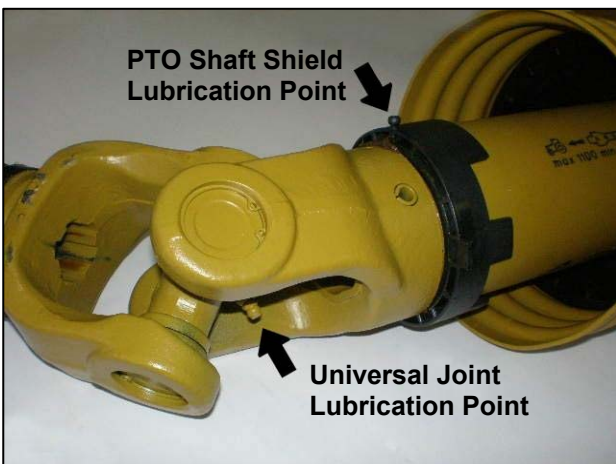

Location of lubrication points



Recommended lubricating frequency

Slide the shaft shield back into place after lubrication ensuring the clasps relocate correctly in the fixing ring – always fit torque chains to the shields to stop them from rotating with the shaft during operation.



McConnel Limited, Temeside Works, Ludlow, Shropshire SY8 1JL. England.
Telephone: 01584 873131. Facsimile: 01584 876463. www.mcconnel.com