

FL 2002

Operation & Spares manual

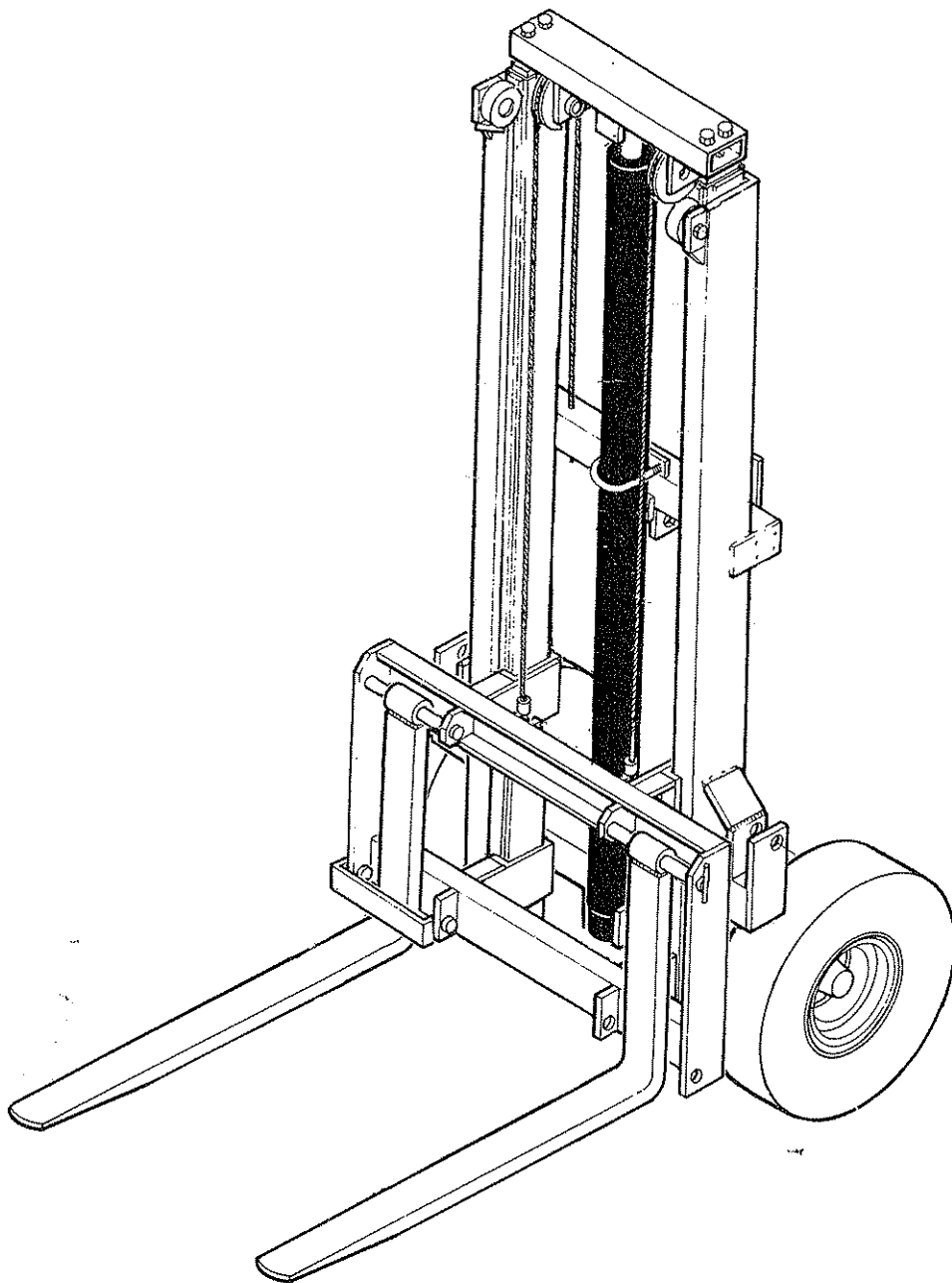

LIST OF CONTENTS

GENERAL INFORMATION	Page	1
SAFETY PRECAUTIONS	Page	2
FITTING	Page	3
Tractor selection	"	3
Tractor preparation	"	3
Attachment to tractor	"	3
Removal from tractor	"	4
Storage	"	4
Fitting hydraulic control valve	"	5
Fitting cable control kit	"	6
Sideshift	"	7
OPERATION	Page	8
Safety	"	8
Machine controls	"	8
Operational limitations	"	8
Pre operational checks	"	9
Operational tips	"	9
MAINTENANCE	Page	10
Lubrication	"	10
Fasteners	"	10
Hydraulic hoses	"	10
Cables	"	10
Hydraulic control valve	"	11
Hose connections	"	13
SPARE PARTS	Page	14

GENERAL INFORMATION

Read this manual before fitting or operating the machine. Whenever any doubt exists contact your dealer or the McConnel Service Department for assistance.

Use only McConnel spare parts on McConnel equipment and machines. This manual includes an illustrated spare parts breakdown and the interpretation which precedes it should be read before ordering replacement components.

DEFINITIONS

The following definitions apply throughout this manual:

WARNING

An operating procedure, technique etc., which can result in personal injury or loss of life if not observed carefully.

CAUTION

An operating procedure, technique etc., which can result in the damage of either machine or equipment if not observed carefully.

NOTE

An operating procedure, technique etc., which is considered essential to emphasise.

Left and Right-Hand

This term is applicable to the machine when fitted to the tractor and viewed from the rear. This also applies to tractor references.

Record the serial number of your machine on this page and always quote this number when ordering spares. Whenever information concerning the machine is requested remember to also state the type of tractor to which it is fitted.

MACHINE SERIAL NUMBER	INSTALLATION DATE
MODEL DETAILS	
DEALERS NAME	
DEALERS TELEPHONE NUMBER	

SAFETY PRECAUTIONS

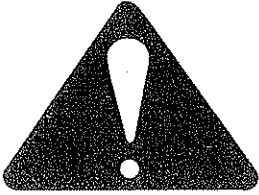

WARNING

- NEVER ... permit inexperienced personnel to operate the machine without supervision.
- ... stand under or behind loaded forks.
- ... exceed the maximum recommended load.
- ALWAYS ... check very carefully that the fork lift can be mounted and operated through its full range of movement when fitted to a tractor with safety cab.
Some types of safety cab render it impossible to fit a fork lift to the tractor.
- ... remember it is illegal to modify the structure of a safety cab to operate a fork lift.
- ... ensure tractor and machine are adjusted for maximum stability.
- ... travel with the load at minimum height (with allowance for uneven surfaces) and with mast tilted towards the tractor.
- ... lower the lift forks and stop tractor engine before carrying out any adjustments or maintenance.
- ... ensure that the lift forks are fully extended under the pallet and that the load is not carried on the tip of the forks.
- ... remove fork lift from the tractor on firm level ground and ensure that it is stable when in the parked position.
- ... check for overhead obstruction prior to working the machine.
- ... check for any difference in pallet sizes, obstacles etc. and ensure that lift forks do not engage adjacent pallets or other obstructions.
- ... ensure that all hoses are not strained, pinched or chafed.
- ... keep tight all bolts and nuts and check security of mounting pins.

FITTING

TRACTOR SELECTION

The tractor selected should have a minimum relief valve setting of 2500 P.S.I. (170 Bar).

Linkage isolation should be available.

Check chains or stabiliser bars must be fitted.

Category 2 linkage is required for the FL2002.

Tractors whose safety cabs project excessively to the rear should be avoided as there is a possibility that the mast will foul the cab during tilting operations.

The FL2002 is a 2032 kg (2ton) rated forklift. To fully utilise this performance the tractor/wheelweight combination must weigh a minimum of 2¼ ton (2750kg).

TRACTOR PREPARATION

Irrespective of the size of tractor it must be stable whilst operating the forklift under all conditions. Rear and front wheel weights should be added up to the manufacturers maximum as necessary. In addition the wheels should be set as wide as practically possible to give maximum stability.

ATTACHMENT TO TRACTOR

With the forklift standing on its wheels and carriage, reverse the tractor up squarely and connect the tractor draft links.

Connect the ram hoses to the tractors hydraulic services. The lift ram should not be connected to a double acting service as the resulting back pressure could result in a slow drop.

With the mast vertical extend the top link ram to about mid stroke. Adjust the screwed end to suit and connect into the tractor's top link jaws...

The top link ram is correctly set when the mast is vertical with the ram at mid-stroke. If problems are encountered an extended Cat. II screwed end is available.

To fit alternative ball ends the retaining pin must be driven out through the access hole in the side of the tube and the end screwed out. Ensure that the retaining roll pin is replaced after fitting the new end as this prevents the ball end being unscrewed beyond the safe minimum engagement.

Tighten check chains/stabiliser bars.

Cut the operation instruction label and stick in a convenient location on or near the control handles. Check that the handle movements correspond to the label. This may mean re-connecting the hoses.

Carefully operate the top link ram and check that the mast does not foul the cab or roll bar when fully retracted.

If clearance cannot be maintained the tractor/cab combination is unsuitable.

Operate the machine through its full range of movements checking that hoses are not pinched, kinked, stretched or chafed.

Check the level of the transmission oil and top up as necessary with oil from the recommended list in the tractors handbook.

REMOVAL FROM TRACTOR

Choose a firm level site

Position the fork retaining bracket as shown and lower the wheels and forks to the ground ensuring that the mast is vertical. Chock the wheels in both directions for extra stability.

Disconnect hydraulics from the tractor and support hose ends clear of the ground.

Disconnect the three point linkage leaving the top link ram connected to the fork lift.

For added stability the fork lift can be left with a weighted pallet on the forks.

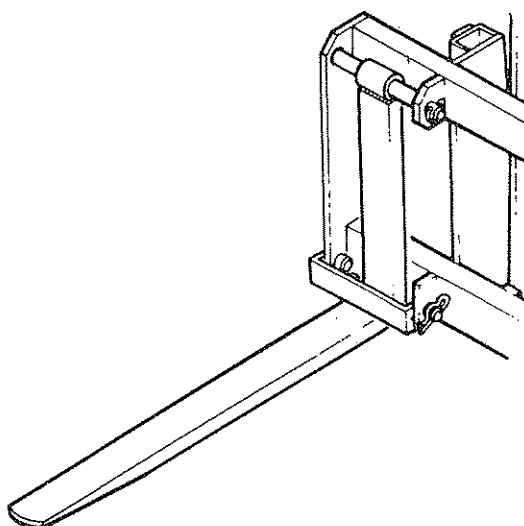

STORAGE

If the machine is to be left standing for an extended period of time lightly coat the exposed portions of the ram rods with grease. Subsequently this grease which becomes contaminated with dust and grit should be wiped off before the rams are next moved.

If the machine is to be stored outside tie a piece of tarpaulin or canvas over the control valve – do not use a plastic bag as this could promote rapid corrosion.

OPTIONAL EXTRAS

HYDRAULIC CONTROL VALVE

Both forklifts are available with their own control valves.

When coupling up the hydraulics the supply and return hoses should go to the tractors gearbox or hydraulic reservoir. Returning the oil through the tractor spool valve is not recommended as the back pressure could result in a slow drop.

On "Dual Power" Ford tractors special installation of the return line will be necessary as per the tractor manufacturers instructions.

John Deere tractors utilise a "closed centre" hydraulic system therefore to operate a forklift with its own control valve certain modifications need to be made. There are the two following alternatives.

A flow limiting valve manufactured by John Deere is available to provide an 'open centre' external supply sufficient for Fork lift requirements. For further advice consult your John Deere dealer.

Alternatively, components are available from F W McConnel to convert the standard 'open centre' valve. The kit, part no. 81 30 059 consists of a relief valve blanking plug which should be installed in place of the existing relief valve. Take care when extracting the relief valve not to damage the copper sealing washer as it is re-used with the blanking plug. In addition a pressure gallery blanking plug is installed in place of the standard blanking plug in the upper position on the valve outlet end.

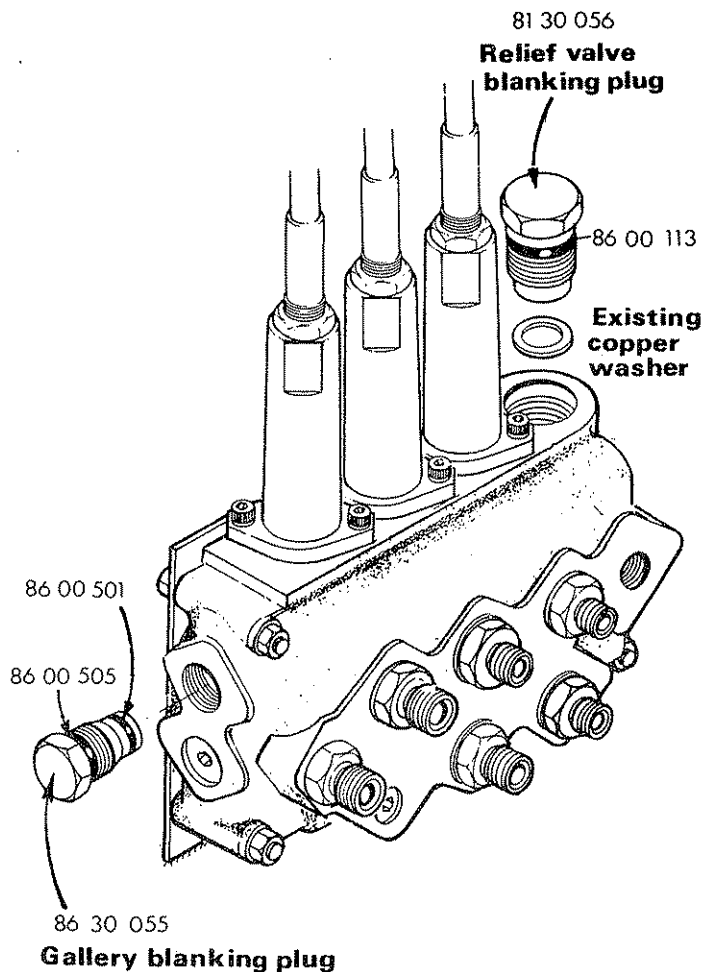

Should the control valve be fitted subsequent to purchase of the fork lift the operator instruction label is mounted on the cross beam below the valve. Re-connect the ram hoses to the service ports indicated on page

CABLE CONTROL KIT

A cable control kit which operates on a push/pull principle is available which mounts in the cab and allows remote control of the control valve.

Installation

The lever pivot boxes must be removed from the control valve and re assembled onto the cable control blocks in accordance with the operating label. Access to the lever pivot pin is beneath the weather gaiter.

Attaching cables to the valve :-

Unscrew the locknut and sleeve and slide up the cable to allow access to fit the cable clevis to the spool end.

Re-position the locknut and sleeve and screw lightly into position on the valve face. Do not fully tighten.

Rotate the sleeve until the levers are at right angles to the cable control blocks, this allows an equal amount of travel in both directions.

Lock in position and fully tighten down the cable flange.

Mounting controls on the tractor.

The control unit is bolted to an adjustable stalk that is attached to a seat bracket which is of universal design for mounting in many models of tractor. The bracket is normally trapped between the seat runners and their mounting base. It may sometimes be necessary to drill extra holes in the seat bracket to accommodate these mounting points or to find the ideal operator position.

On tractors other than quiet cab models it is permissible to attach the control unit to the mudwing or the cladding of the cab observing the proviso that no structural member of the cab should be drilled. For this purpose the stalk can be bent round in a 'U' shape.

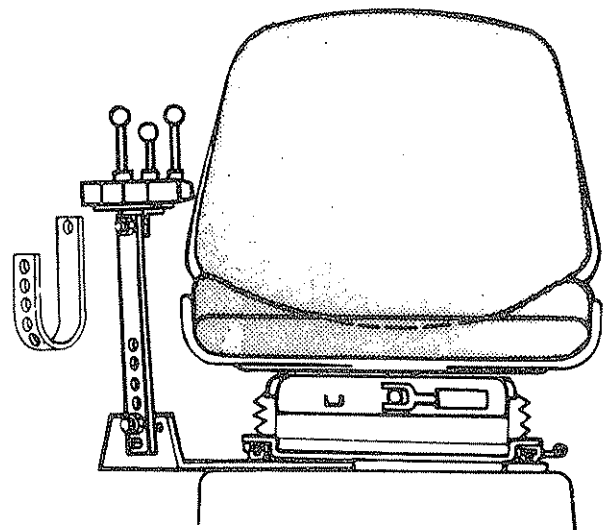

In deciding the final position of the control unit consider that tight bends in the cable will reduce their operational life. The cable run should be as straight as possible with any bends having a minimum radius of 8".

SIDESHIFT

Fitting:-

Remove the forks and fit the sideshift frame to the carriage. Refit the forks to the sideshift frame.

Assemble the sideshift ram into position with the base end connected to the right hand slide pin and the rod end between the lugs on the sideshift frame.

Route the hoses down and around the outside of the mast, from where they sweep back up and connect to either the vacant hydraulic outlets on the tractor or the relevant service ports on the forklifts hydraulic control valve. See page

Liberally grease the sideshift slides in preparation for work.

Where the forklift has its own hydraulic control valve operate the sideshift and check that the motion coincides with the operator instruction label.

OPERATION

SAFETY

Read the instruction book carefully before attempting to operate the machine paying particular attention to aspects relating to safety. **THEY ARE THERE FOR YOUR OWN GOOD.**

MACHINE CONTROLS

Before commencing work select a clear unobstructed site and operate the forklift without load until the controls and the feel of the machine are familiar. This is a wise precaution for all operators and a must for the inexperienced.

OPERATIONAL LIMITATIONS

NEVER NEVER attempt to exceed the maximum safe working load shown below.

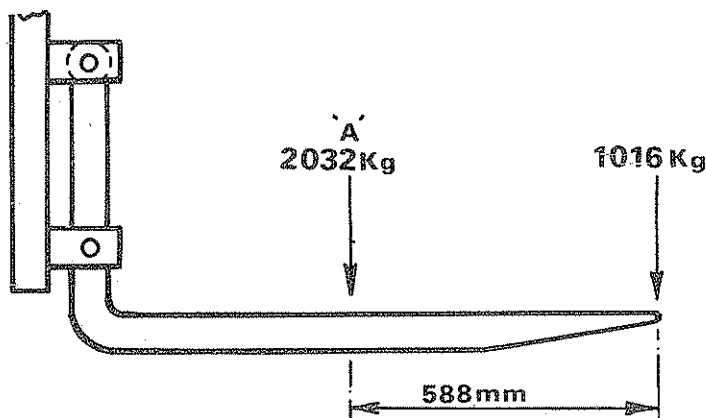

The tractor/forklift combination must be stable under all working conditions.

The FL 2002 is a 2032kg (2Ton) rated forklift. To fully utilise this performance the tractor/wheelweight combination must weigh a minimum of 2¼ Ton (2750kg)

Never exceed the tractors manufacturers recommended maximum wheel weights in an attempt to bring the unit up to the 2000 kg minimum weight required.

If operating with a tractor/wheel weight combination of less than 2000kg (2 ton) the safe working load must be reduced accordingly.

Eg. For a tractor/wheel weight combination of 1500kg (1½ tons) the maximum safe working load at point 'A' would be 1150kg.

PRE OPERATIONAL CHECKS.

Check that hoses do not get pished, kinked or stretched during operation.

Check that machine movements correspond to the operation instruction decal.

Check that all pins and fasteners are secure.

Check daily that the forklifts wheel nuts are tight and that tyre pressure is 70 psi

Check that the clearance between the carriage rollers and the mast channel is 1½ mm (1/16 ins) per side. As wear occurs this clearance must be maintained by shimming the rollers as shown on page

Check that the side and inner faces of the mast channel; the fork slides and the sideshift slides, if fitted, are liberally greased.

OPERATIONAL TIPS

Set the forks as wide as possible.

When driving under the pallet check that the fork tips do not engage adjacent pallets or any other obstructions.

Ensure that the lift forks are fully extended under the load and that the load is not carried on the tip of the forks.

Before raising the load check that there are no overhead obstructions, this is especially important when working inside a building or in the vicinity of overhead cables.

WARNING

To avoid the possibility of flashover in the vicinity of high voltage overhead power lines never work closer than 1.5 metres minimum. If in any doubt consult the local electricity board or leave officer for advice on a safe plan of working.

When transporting, tilt the mast towards the tractor and carry the load as low as possible making allowances for uneven surfaces and ensure that the sideshift, if fitted, is centrally located on the carriage. During transport the linkage should be set in position control with the fork lift wheels just making contact with the ground and only carrying a small proportion of the load. Too much weight on the wheels will cause rapid wear of the wheel bearings and tyres.

If encountering traction problems in soft ground conditions the three point linkage of the tractor may be raised slightly to remove all the load from the fork lift wheels and provide weight transfer to the rear wheels of the tractor. This manoeuvre is carried out in 'Position Control!'

Do not exceed 3 mph when travelling with loaded forks.

Operating a forklift on sloping ground is not recommended but if it is absolutely unavoidable always reverse directly up the slope when loaded.

On approaching the unloading area raise the forks to the minimum height necessary and complete the approach slowly.

MAINTENANCE

LUBRICATION

Grease liberally at daily intervals the sliding faces of the outer mast, inner mast and fork carriage

In addition the side shift slides, if fitted should be greased similarly.

FASTENERS

Ensure that all nuts and bolts are tight, and that pins are in position and securely fixed.

HYDRAULIC HOSES

The condition of all hoses should be checked during routine servicing. Hoses that have been chafed or damaged on their outer casing should be securely wrapped with waterproof adhesive tape to prevent the metal braid from rusting. Hoses that have suffered damage to the metal braid should be replaced immediately.

Hose replacement:-

Replace one hose at a time to avoid the risk of wrong connections.

When the hose is screwed to an additional fitting or union, use a second spanner on the union to avoid breaking both seals.

Do not use jointing compound on threads.

Avoid twisting the hose. Adjust the hose line to ensure freedom from rubbing or trapping before tightening the hose and connections.

Hose Warranty:-

Warranty is limited to replacement of hoses which have failed due to faulty manufacture or materials. Warranty will not be considered on hoses that have suffered damage by abrasion, cuts or being pinched or trapped in work.

Neither will a claim be considered where the hose end has been damaged by a blow or where the threads of the unions have been damaged by overtightening.

CABLES

The cables operate on a push/pull system with the spool centring springs always returning the spool to the neutral position when the handle is released.

Care should be taken during installation and operation to ensure that the cables are not trapped or kinked. Any abrasion or damage to the outer casing should be sealed with plastic insulation tape to prevent moisture penetrating the cable.

No routine adjustment of the cables are necessary as they do not stretch. The threaded sleeve is correctly adjusted when the handle is at right angles to the cable spindle block.

Caution;- On no account should any attempt be made to lubricate the cables which are assembled with a special lubricant during manufacture.

HYDRAULIC CONTROL VALVE.

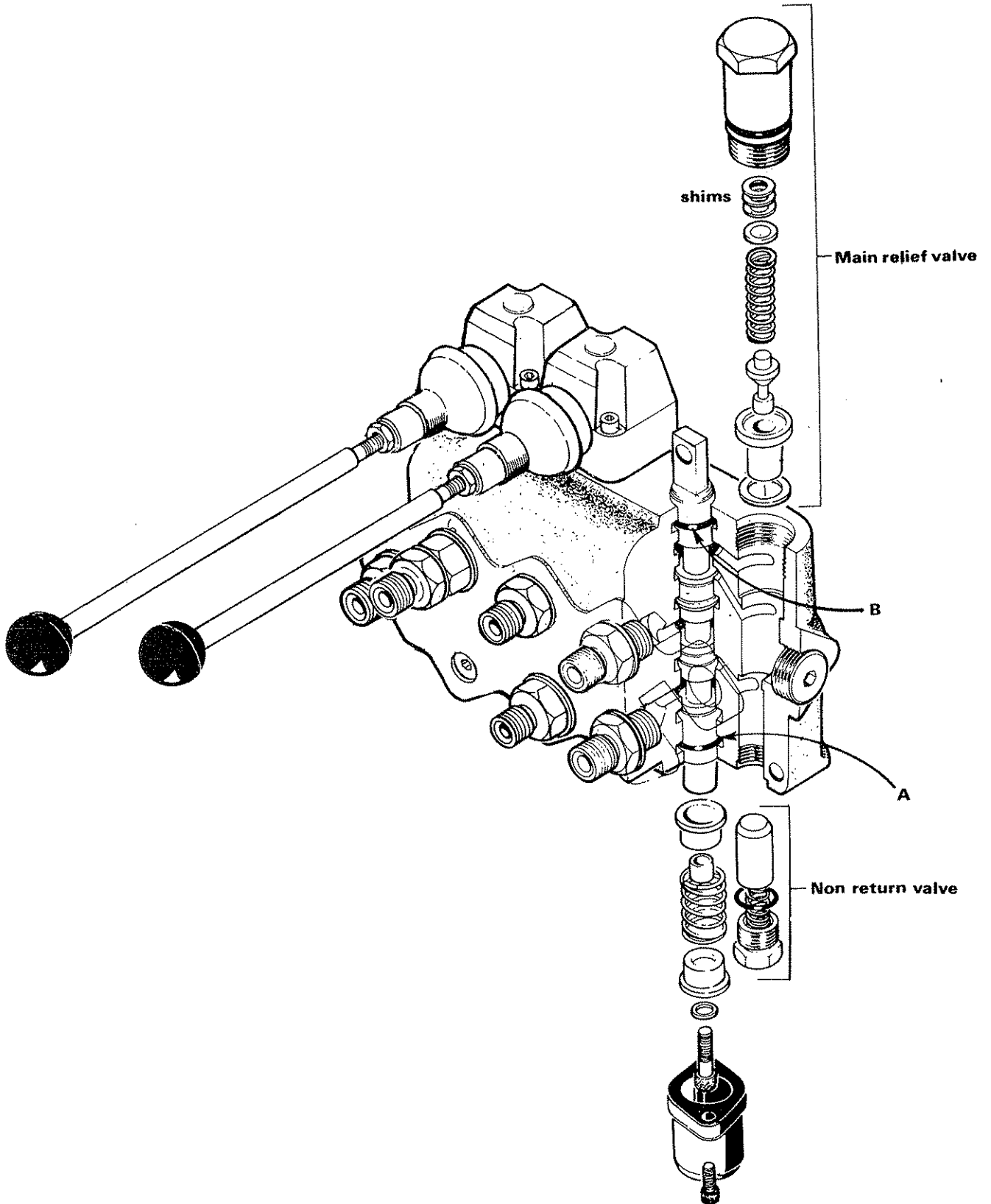

Non Return Valve

The non return valve prevents the feedback of oil from the service parts. It is unlikely to need attention but if remove for cleaning a new 'O' ring should be used when refitted.

Replacing spool 'O' rings

Note: Owing to the sharp edges in the design of the spool, failure to carry out the following procedure could result in damage to the 'O' rings resulting in external leakage.

Extract the lever pivot pin and remove the lever and lever pivot box from the valve. Alternatively remove the cable end from the spool.

Remove the cover at the opposite end of the spool and unscrew the return spring or detent assembly whichever is necessary.

Pull the spool through the block from the handle end, until the 'O' ring marked 'A' is accessible. Remove the 'O' ring from its groove using a smooth edged hook.

Completely remove the spool from the block out of the return spring end.

Remove the 'O' ring marked 'B' and refit the new 'O' ring.

Lightly oil the spool and replace it in the block from the return spring end pushing it through far enough to clear the 'O' ring groove 'A'.

Fit new 'O' ring in groove 'A'.

Push the spool back through from the handle end far enough to re assemble the return spring or detent assembly plus the cover.

Re-assemble the lever pivot box/lever assembly on the cable end of the valve.

Main Relief Valve

The main relief valve is shim calibrated to 2500 PS1 (170 Bar). A sticking relief valve will probably cause overheating and/or loss of Power. If this is suspected it should be dismantled and examined for dirt and damage. Undo the large hexagon housing, the relief valve spring, needle and seat can now be withdrawn together with the shims and washer. Take particular care not to loose the calibrating shims. If difficulty is experienced in extracting the seat remove the non-return valve at the bottom of the gallery and drive out with a soft brass drift. Take care not to damage the copper sealing washer positioned between the seat and the locating shoulder in the block.

Blow out the valve with compressed air, if any part of the valve is damaged a new relief valve assembly is required. On renewal, a reliable pressure guage in the supply circuit must be used to check relief valve pressure which can be adjusted by use of selection of shims supplied with the relief valve kit. Under no circumstances should adjustment be attempted without the aid of a pressure gauge otherwise serious damage to the machine could result.

Use a new 'O' ring when refitting the valve.

An alternative main relief valve stamped 170 Bar may be supplied which is factory pre-set and is not adjustable. In the event of damage to any part of this valve a complete new unit is required.

HOSE CONNECTIONS
BSP Valve shown illustrated

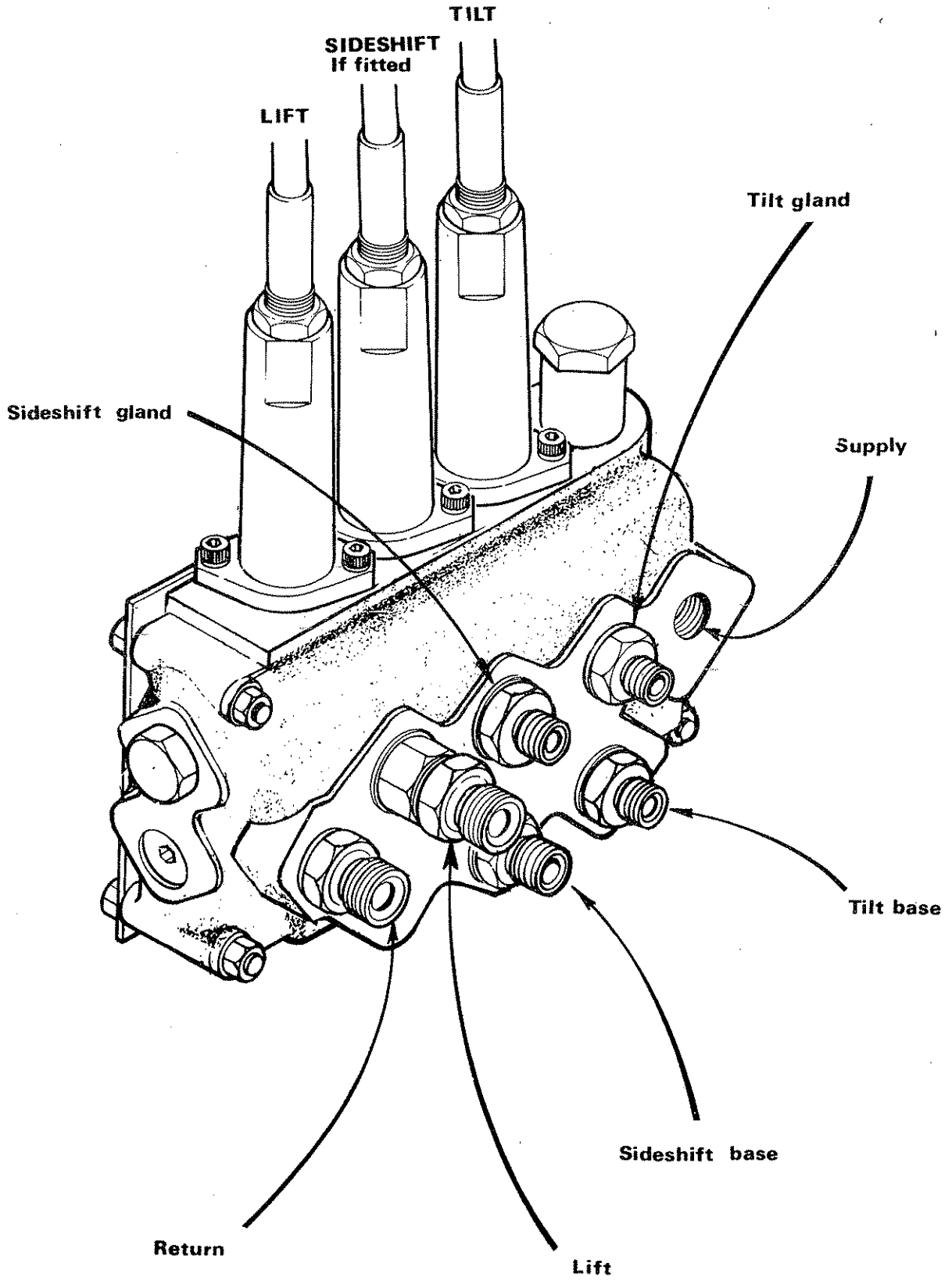

SPARE PARTS MANUAL

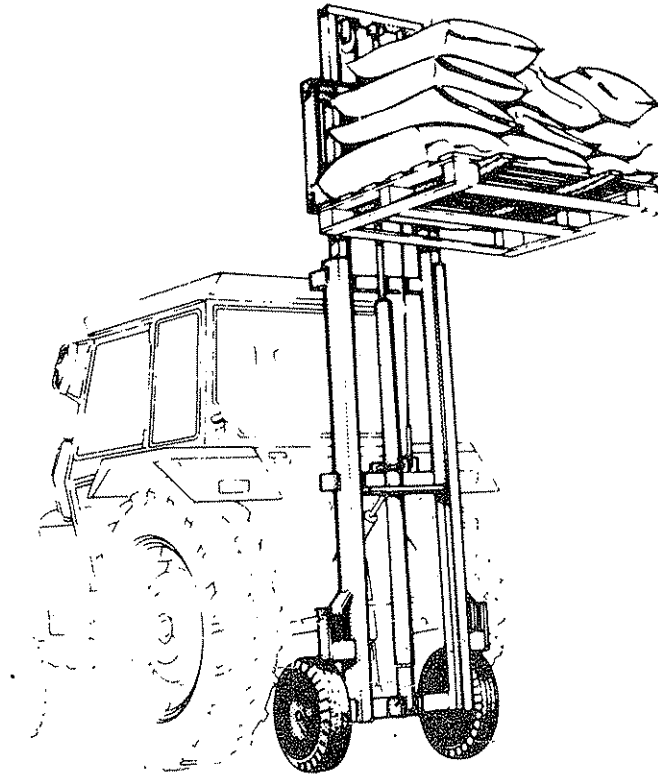

FOR BEST PERFORMANCE....

USE ONLY McCONNEL SPARE PARTS

To be assured of the latest design improvements purchase your genuine replacements from the original equipment manufacturer F.W.McConnel Ltd. through your local dealer or stockist.

Always quote machine type and serial number as well as the part number.

Design improvement may have altered some of the parts listed in this manual - The latest part will always be supplied when it is interchangeable with an earlier one.

Model. |

GENERAL ASSEMBLY

MCCOMEL

Registered office: Temeside Works,
Ludlow, Shropshire SY8 1JL, England.
Telephone: Ludlow (0584) 3131
Telex: 35313

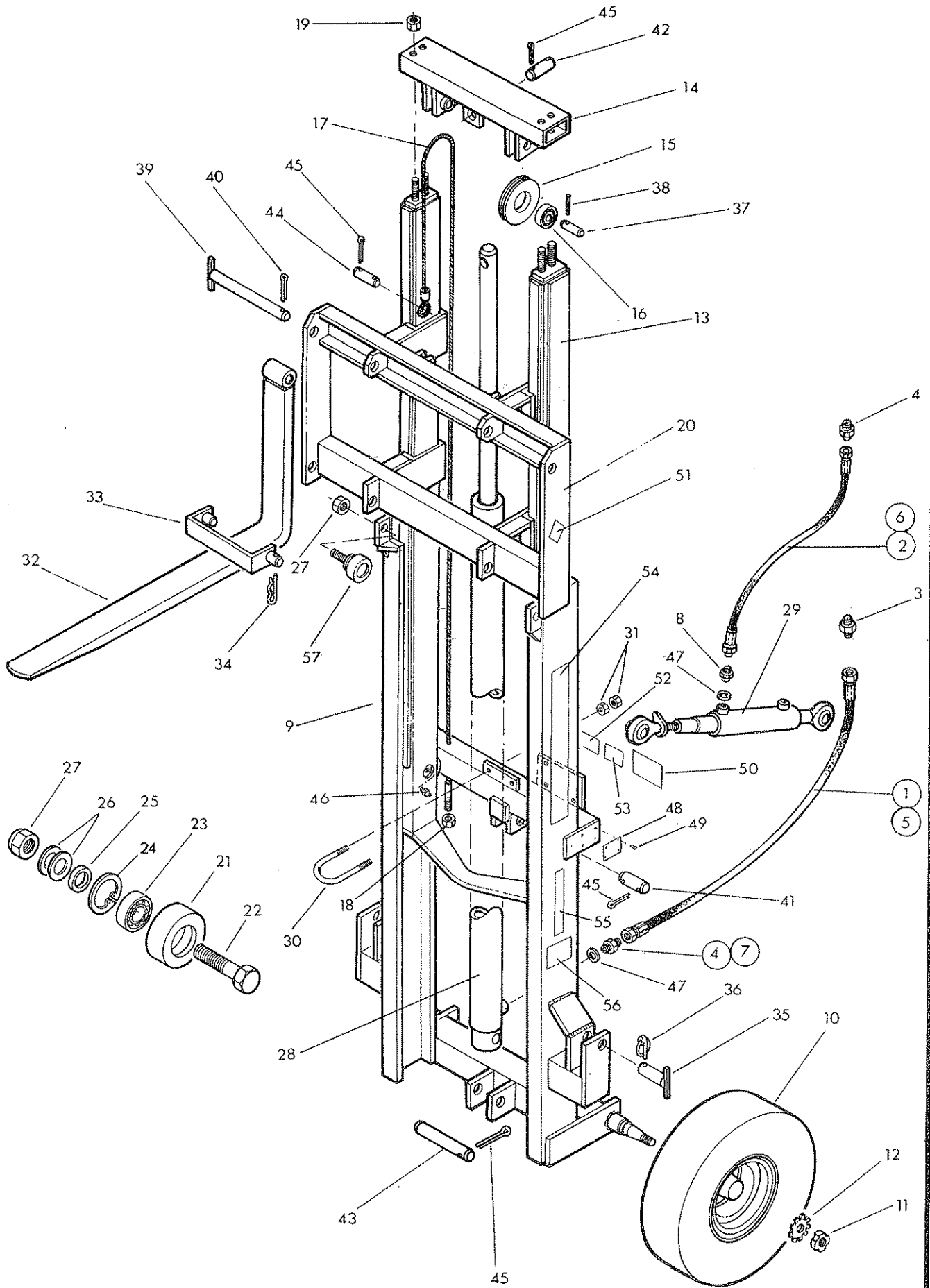

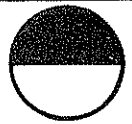

Ref	Part No.	Qty	Description
	10 20 400		FL2002 with BSP HYDRAULICS
1	85 13 054	1	Hose ½ BSP SF x 65" long-lift
2	85 21 043	2	Hose 3/8 BSP SM-SF x 45" long-tilt
3	85 81 110	1	Union ½" BSP M-M
4	60 00 112	3	Union 3/8 BSP ½" BSP MM
	10 20 402		FL2002 with J.I.C. HYDRAULICS
5	85 13 109	1	Hose 7/8 JIC SF x 65" long-lift
6	85 11 888	2	Hose ¾ JIC SF x 45" long-tilt
7	85 81 222	1	Union 3/8 BSP - 7/8 JIC MM
8	71 03 062	2	Union 3/8 BSP ¾ JIC MM

The following items are common to both fork lift assemblies

9	10 20 408	1	Outer mast
10	10 20 427	2	Wheel tyre and hub assy. see page 23
11	10 20 092	2	Special axle nut
12	10 20 091	2	Tab washer
13	10 20 409	1	Inner mast
14	10 20 413	1	Pulley cross member
15	10 20 088	2	Pulley
16	06 00 080	2	Bearing
17	10 20 089	2	Lift cable
18	01 41 008	2	Self locking nut 7/8 UNF
19	91 43 006	4	Self locking nut M12
20	10 20 414	1	Carriage
21	10 20 267	2	Roller
22	10 20 025	2	Special bolt
23	06 00 075	2	Bearing
24	04 16 252	2	Internal circlip
25	10 20 024	2	Spacer
26	10 20 023	as reqd	Shroud washer
27	91 43 008	2	Self locking nut M20
28	10 20 419	1	Lift ram
29	10 20 420	1	Tilt/top link ram
30	10 20 095	1	U Bolt
31	91 13 005	4	Nut M10
32	10 20 365	2	Fork
33	10 20 362	1	Fork retaining bracket
34	04 31 105	1	Spring cotter
35	10 20 030	2	Linkage pin lower Cat II
36	04 31 217	2	Linch pin
37	10 20 109	2	Pulley axle
38	04 21 824	2	Spring dowel ½" dia. x 1½" long
39	10 20 071	2	Fork mounting pin
40	05 03 165	2	Split pin 3/16" dia. x 2"
41	10 20 031	1	Linkage pin top Cat II
42	10 20 094	1	Pin - lift ram rod
43	10 20 070	1	Pin - lift ram base
44	10 20 110	2	Pin - cable anchor
45	95 01 405	10	Split pin Ø5 x 40
46	09 01 121	2	Greaser 1/8 BSP straight
47	86 50 103	3	Bonded seal 3/8 BSP
48	13 35 246	1	Serial No. plate
49	71 03 230	4	Pop rivet 1/8
* 50	12 90 010	1	Sticker - machine controls
51	71 05 130	1	Sticker - read instruction book
52	71 35 295	1	Sticker - Check chains
53	12 90 277	1	Sticker - Safe working load
54	12 90 271	2	Sticker - 'McConnell'
55	12 90 274	2	Sticker - 'Ripvator'
56	12 90 007	2	Sticker - 2002
	SUB ASSEMBLY		
57	10 20 022	2	Roller assembly c.mpr:- items 21 - 26

* Assembly note - Positioned on mast crossmember beneath control valve if valve is supplied, or sent loose if machine is tractor controlled

Model.

SIDESHIFT KIT

MCCONEL

Registered office: Temaside Works,
Ludlow, Shropshire SY8 1JL, England.
Telephone: Ludlow (0584) 31 31
Telex: 35313

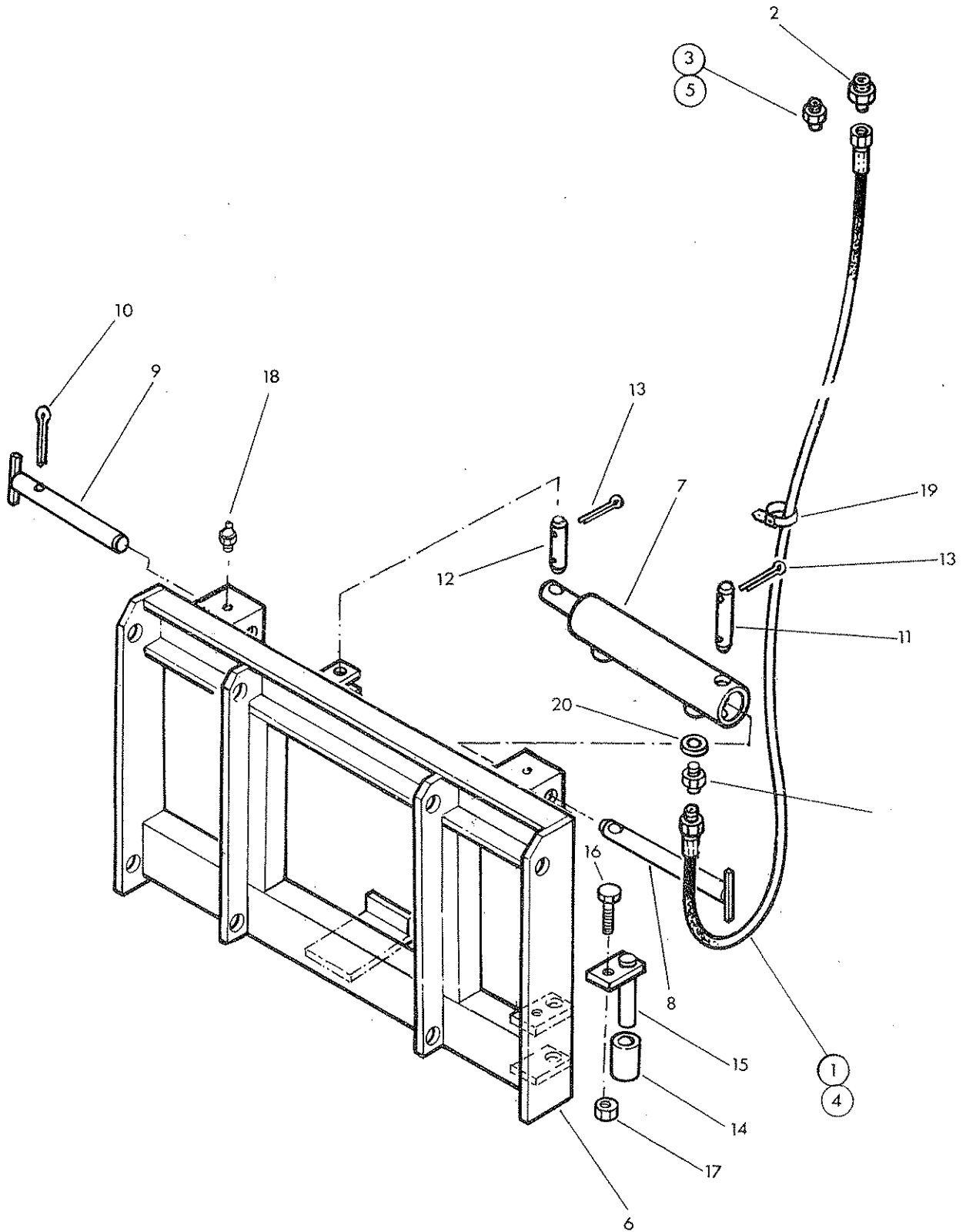
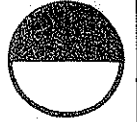



Ref	Part No.	Qty	Description
	10 20 401		FL2002 with BSP HYDRAULICS AND SIDESHIFT
	10 20 403		FL2002 with J.I.C. HYDRAULICS AND SIDESHIFT

The spares list for the above are as their counterparts on the previous page, plus the following items

	10 20 415		SIDESHIFT KIT BSP HYDRAULICS
1	85 21 063	2	Hose 3/8 BSP SM SF x 128" long
2	60 00 112	2	Union 3/8 BSP 1/2 BSP M-M (Tractor connection)
3	60 00 113	2	Union 3/8 BSP MM (Control valve connection - if fitted)
	10 20 416		SIDESHIFT KIT J.I.C. HYDRAULICS
4	85 11 898	2	Hose 3/8 J.I.C. SF x 128" long
5	71 03 062	2	Union 3/8 BSP - 3/8" J.I.C.

The remaining items are common to both sideshift assemblies

6	10 20 417	1	Sideshift frame
7	10 20 283	1	Sideshift ram
8	10 20 067	1	Slide pin - long
9	10 20 068	1	Slide pin - short
10	95 01 509	1	Split pin Ø10 x 50
11	10 20 033	1	Pin - ram base
12	10 20 034	1	Pin - ram rod
13	95 01 406	4	Split pin Ø5 x 4
14	10 20 075	2	Roller
15	10 20 076	2	Pin roller
16	93 13 065	2	Setscrew M10 x 30
17	91 43 005	2	Self locking nut M10
18	09 01 121	2	Greaser 1/8 BSP straight
19	71 06 187	2	Plastic hose tie
20	86 50 103	2	Bonded seal 3/8 BSP

Model.]

CONTROL VALVE KIT

McCONEL

Registered office: Temeside Works,
Ludlow, Shropshire SY8 1JL, England.
Telephone: Ludlow (0584) 3131
Telex: 35313

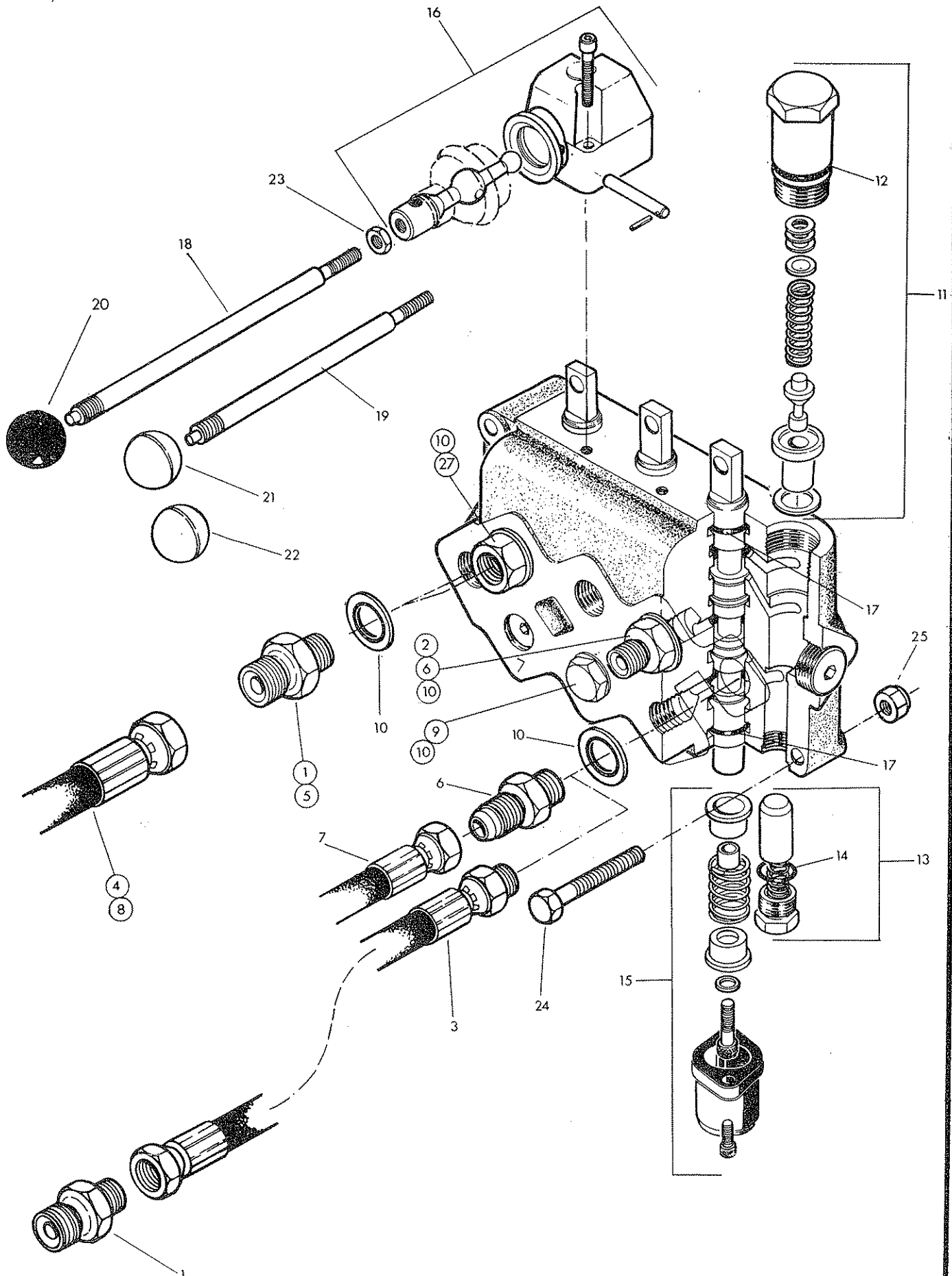
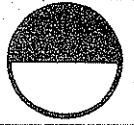

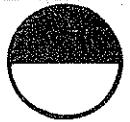

OPTIONAL EXTRA

Ref	Part No.	Qty	Description
	10 20 290		CONTROL VALVE KIT - BSP
1	60 00 112	3	Union 3/8 BSP - 1/2 BSP MM
2	60 00 113	2	Union 3/8 BSP - MM
3	85 21 043	1	Hose - supply - 3/8 BSP SF-SM x 45" long
4	85 23 104	1	Hose - return - 1/2 BSP SF - SM x 45" long
	10 20 291		CONTROL VALVE KIT - JIC
5	85 81 222	2	Union 3/8 BSP - 7/8 JIC MM
6	71 03 062	3	Union 3/8 BSP - 3/4 JIC MM
7	85 11 888	1	Hose - supply 3/4 JIC SF - SF x 45" long
8	85 23 109	1	Hose - return 7/8 JIC SF - SM x 45" long

The following items are common to both control valve kits

9	80 03 001	2	Blank plug 3/8 BSP
10	86 50 103	8	Bonded seal 3/8" BSP
	81 30 261	1	Valve assembly complete with:-
11	81 30 023	1	. Main relief valve 2500 PSI (170 Bar)
12	86 00 113	1	.. 'O' Ring
13	81 30 022	1	. Non return valve assembly
14	86 00 501	1	.. 'O' Ring
15	81 30 134	3	. Spool centering assembly
16	81 30 065	3	. Lever pivot box assembly
17	86 00 112	6	. Spool 'O' ring
18	71 09 131	2	Lever - long
19	71 09 132	1	Lever - short
20	09 03 114	1	Knob - yellow - lift
21	09 03 113	1	Knob - green - sideshift
22	09 03 112	1	Knob - red - tilt
23	91 13 004	3	Locknut M8
24	92 13 114	3	Bolt M8 x 55
25	91 43 004	3	Self locking nut M8
26	12 90 010	1	Operating sticker - Not illustrated
27	85 81 238	1	Extension adaptor 3/8 BSP M-F
	86 99 163		VALVE SEAL KIT

Model.

CABLE CONTROL KIT

McCONEL

Registered office: Temeside Works,
Ludlow, Shropshire SY8 1JL, England.
Telephone: Ludlow (0584) 3131
Telex: 35313

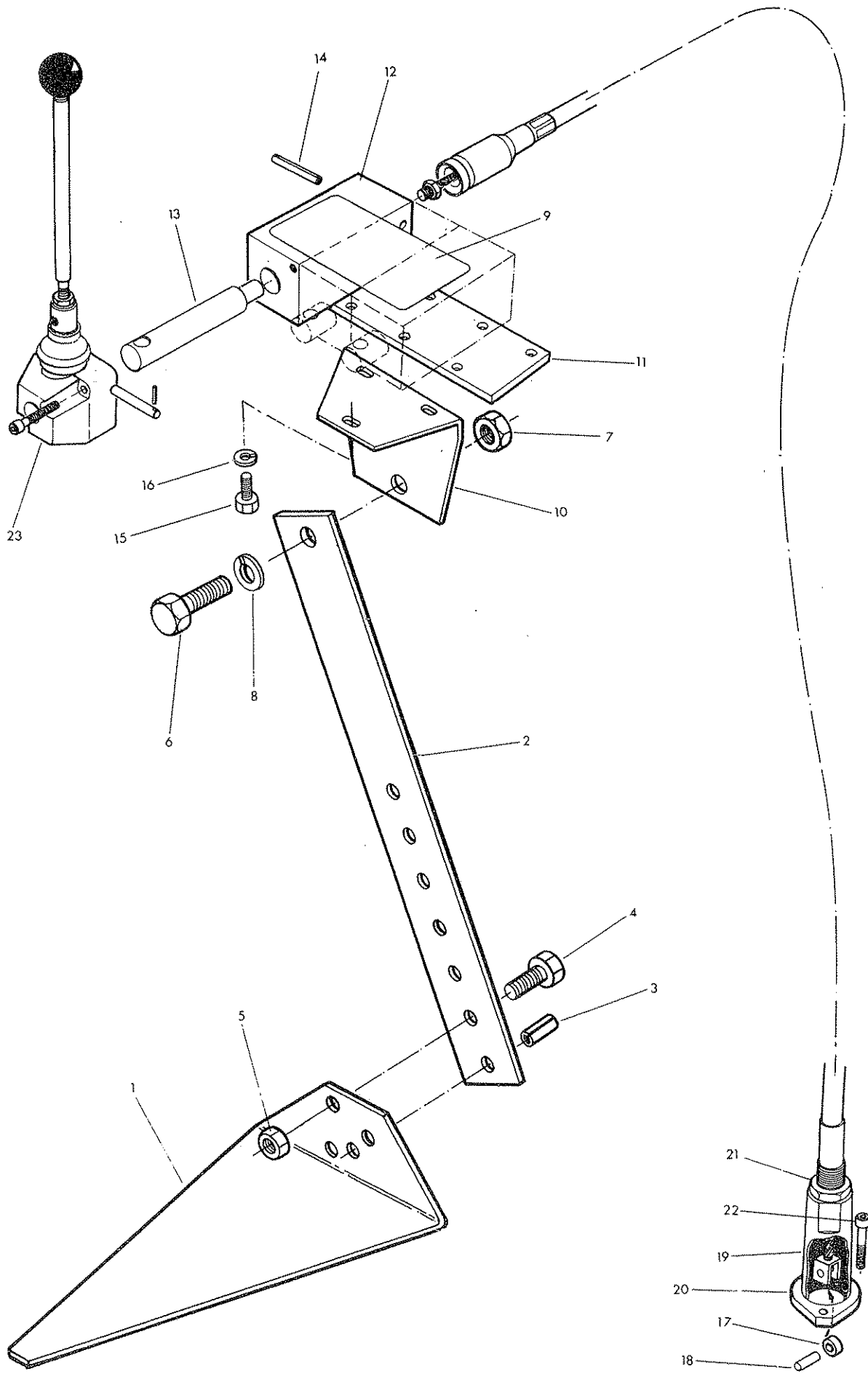



Ref	Part No.	Qty	Description
	10 20 295		CABLE KIT - OPTIONAL EXTRA
	71 09 319	1	Valve mounting Plate & pillar compr:-
1	71 09 320	1	. Sandwich Plate
2	71 09 146	1	. Pillar complete with sp. dowel
3	04 22 816	1	. Spring dowel
4	93 13 066	1	. Setscrew M12 x 30
5	91 13 006	1	. Nut M12
6	03 11 086	1	. Setscrew 5/8 UNF x 1" long
7	01 11 006	1	. Plain nut 5/8 UNF
8	01 00 206	1	. Spring washer 5/8 dia
9	12 90 011	1	Operator label
10	80 17 006	1	Control bracket
11	71 14 071	1	Control block mounting base
12	81 30 052	3	Control block
13	81 30 053	3	Spindle
14	04 25 522	3	Spring dowel $\varnothing 5 \times 22$
15	93 13 034	6	Setscrew M8 x 16
16	91 00 104	6	Plain washer $\varnothing 8$
*	10 20 040	3	Cable assy 1.5 M c/w sleeve flange etc
17	71 15 158	1	. Spacer
18	71 15 160	1	. Pin
19	71 15 162	1	. Sleeve
20	81 25 050	1	. Flange
21	01 31 006	1	. Thin locknut 5/8 UNF
22	93 43 032	6	Capscrew - socket hd - M5 x 16

* Spares note:-

An alternative cable assembly may be fitted depending on supply availability.

The complete assembly is interchangeable and thus retains the same assembly Part No. 10 20 040.

Individual cable components are not interchangeable thus before ordering spares the cable must be correctly identified.

The cable listed above is manufactured by "BOWDEN" and is BLACK.

The alternative cable manufactured by "TELEFLEX MORSE" is RED and comprises of :-

	10 20 040	3	Cable assy 1.5 M c/w Flange etc
17	80 17 004	1	. Spacer
18	80 17 005	1	. Pin
19	81 25 049	1	. Sleeve
20	81 25 050	1	. Flange
21	91 00 016	1	. Thin locknut $\varnothing 16 \times 1.5$ pitch

23 Lever pivot box c/w handle is shown for ref only.

When cable kits are supplied subsequently as conversions the lever pivot box is dismantled from the control valve and assembled to the cable block in the position shown.

Model.

WHEEL & HUB

McCOMEL

Registered office: Tameside Works,
Ludlow, Shropshire SY8 1JL, England.
Telephone: Ludlow (0584) 3131
Telex: 35313

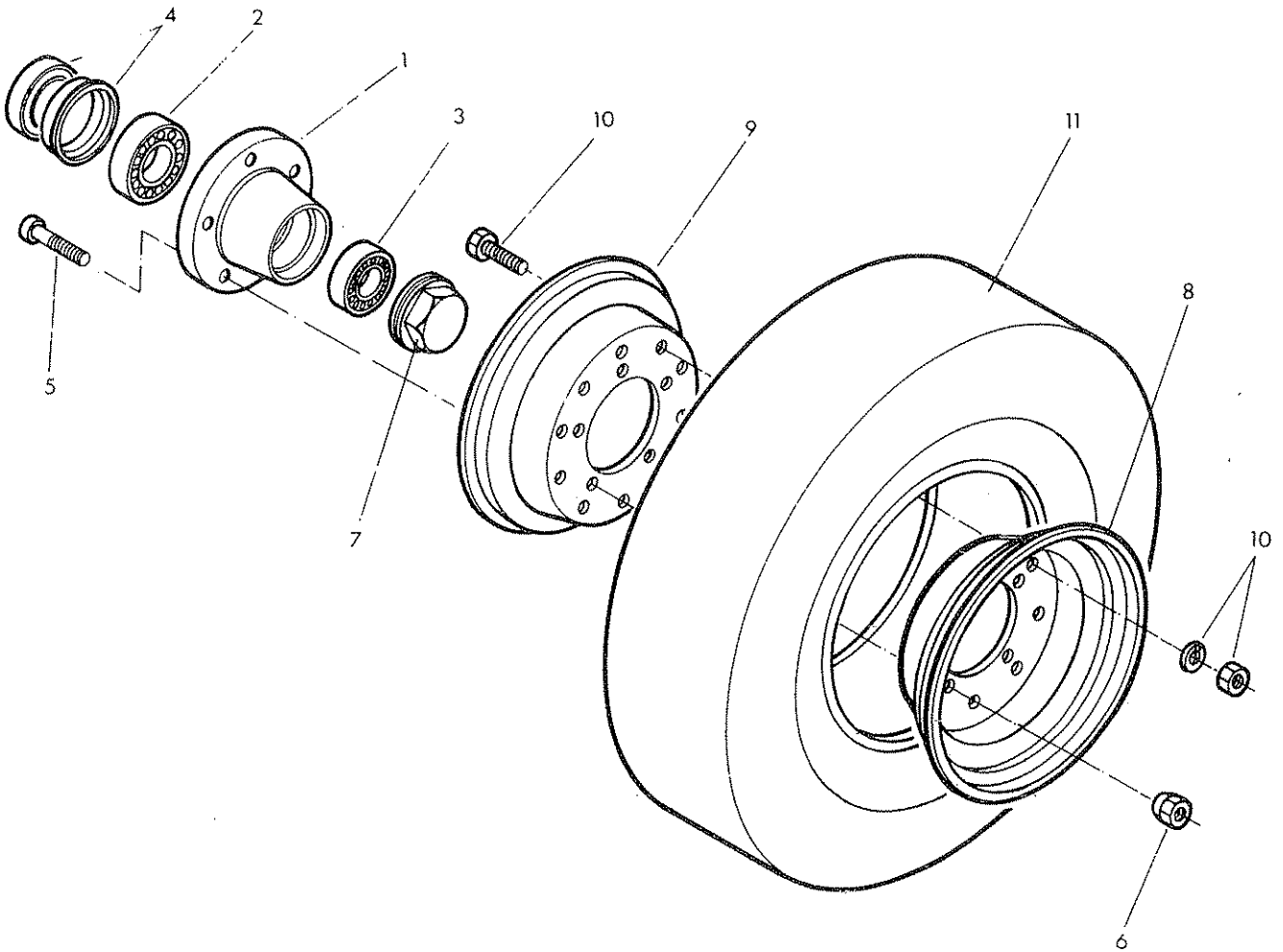
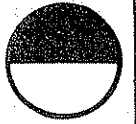

Ref	Part No.	Qty	Description.
	10 20 427	2	WHEEL, TYRE AND HUB ASSEMBLY comprising :-
1	10 20 435	1	Hub
2	06 00 078	1	Inner bearing
3	06 00 079	1	Outer bearing
4	86 29 167	1	Labrynth seal
5	10 20 045	5	Wheel stud
6	10 20 036	5	Stud nut
7	10 20 093	1	Hub cap
8	10 20 430	1	Outer rim
9	10 20 431	1	Inner rim
10	10 20 272	10	Rim bolt c/w nut and washer
11	10 20 432	1	Tyre 6.00 x 9 - 10 ply
12	10 20 433	1	Inner tube 6.00 x 9) not illustrated
13	10 20 434	1	Tyre line 6.00 x 9)

SUB ASSEMBLIES

- 10 20 429 Hub assembly compr:- items 1 - 7
- 10 20 428 Rim and tyre compr:- items 8 - 13

Model.

HYDRAULIC RAMS

McCONNEL

Registered office: Temeside Works,
Ludlow, Shropshire SY8 1JL, England.
Telephone: Ludlow (0584) 3131
Telex: 35313

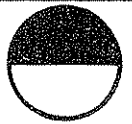

10 20 419
86 99 210

LIFT RAM ASSEMBLY FL2002
Seal kit

10 20 420
86 99 211
10 20 047
10 20 069
10 20 049

TILT/TOP LINK RAM ASSEMBLY FL2002
Seal kit
Category 2 screwed end
Spring dowel
Locking collar 1¼ UNC

Optional Extra

10 20 044

Extended Category 2 screwed end

10 20 283
86 99 207

SIDESHIFT RAM ASSEMBLY FL2002
Seal kit

F W McConnell Ltd

agricultural & industrial machinery

Registered office: Temeside Works
Ludlow, Shropshire, SY8 1JL England

registered number 305192 England

telephone: Ludlow 3131 (std 0584)

telex: 35313

cables: Powerarm Ludlow

